

MHI
Copy 3

FM 21-26

WAR DEPARTMENT

BASIC FIELD MANUAL



**ADVANCED MAP AND AERIAL
PHOTOGRAPH READING**

September 17, 1941

FM 21-26

BASIC FIELD MANUAL

**ADVANCED MAP AND AERIAL
PHOTOGRAPH READING**

**Prepared under direction of the
Chief of Engineers**



**UNITED STATES
GOVERNMENT PRINTING OFFICE
WASHINGTON : 1941**

WAR DEPARTMENT,
WASHINGTON, September 17, 1941.

FM 21-26, Advanced Map and Aerial Photograph Reading, is published for the information and guidance of all concerned.

[A. G. 062.11 (5-15-41).]

BY ORDER OF THE SECRETARY OF WAR:

G. C. MARSHALL,
Chief of Staff.

OFFICIAL:

E. S. ADAMS,
Major General,
The Adjutant General.

DISTRIBUTION:

D (3); B 1, 2, 4, 6, 7, 17 (2); R 1-7, 10, 17 (5); Bn 1 (10),
2-7, 11, 17 (5), 9, 10 (2); C 2, 5-7, 17 (10), 1, 3, 4,
9-11 (5).

(For explanation of symbols see FM 21-6.)

TABLE OF CONTENTS

	Paragraphs	Page
SECTION I. General -----	1-9	1
II. Distance -----	10-15	10
III. Direction, orientation, and location -----	16-28	20
IV. Coordinates -----	29-38	41
V. Elevation and relief -----	39-48	61
VI. Slope, profile, and visibility -----	49-60	73
VII. Aerial photographs -----	61-75	87
VIII. Identification of terrain features on single photograph -----	76-88	113
IX. Stereovision and examination -----	89-93	129
X. Preparation of aerial photographs for use as map substitute -----	94-114	148
XI. Photomaps -----	115-120	175
INDEX -----		183

BASIC FIELD MANUAL

ADVANCED MAP AND AERIAL PHOTOGRAPH READING

(This manual supersedes TM 2180-5, September 28, 1938.)

SECTION I

GENERAL

■ 1. **PURPOSE.**—The purpose of this manual is to provide a text on map and aerial photograph reading for training of military personnel already familiar with basic elements covered by FM 21-25 or who require more detailed instruction than is furnished by FM 21-25.

■ 2. **SCOPE.**—Sections I to VI, inclusive, cover an exposition of factors and methods employed in map reading. Sections VII to XI, inclusive, provide an extension of these factors and methods into the related field of aerial photograph reading. The large-scale aerial photograph, within its characteristic limitations, is the logical complement of the small-scale map. Knowledge of the characteristics of aerial photographs and proficiency in the basic art of map reading are prerequisites to proficiency in aerial photograph reading.

■ 3. **DEFINITION.**—A map is a conventional representation of a portion of the surface of the earth as a plane surface. Since a spherical surface cannot be reproduced as a plane with absolute accuracy, the representation is approximate only, with characteristics dependent upon the projection employed.

■ 4. **PROJECTION.**—*a. Shape of earth.*—Theoretically, the earth is an oblate spheroid in shape; a figure formed by rotating an ellipse around its shorter axis. Because of the continents and islands, the actual surface is slightly irregular. The distance from the center of the earth to a point at sea level on the Equator is 3,963.3 statute miles and the distance from the center of the earth to either of the poles at sea level is 3,950 statute miles. This difference is so slight that the earth may be mentally pictured as a round ball

or sphere which rotates on a line or axis passing through its center. The imaginary intersections of this axis with the surface of the earth are called the North and South Poles. Circles on the earth's surface, cut by imaginary planes passing through the poles, are called meridians of longitude (fig. 1). Circles cut by imaginary planes at right angles to the axis are called parallels of latitude. The parallel midway between the poles is called the Equator and

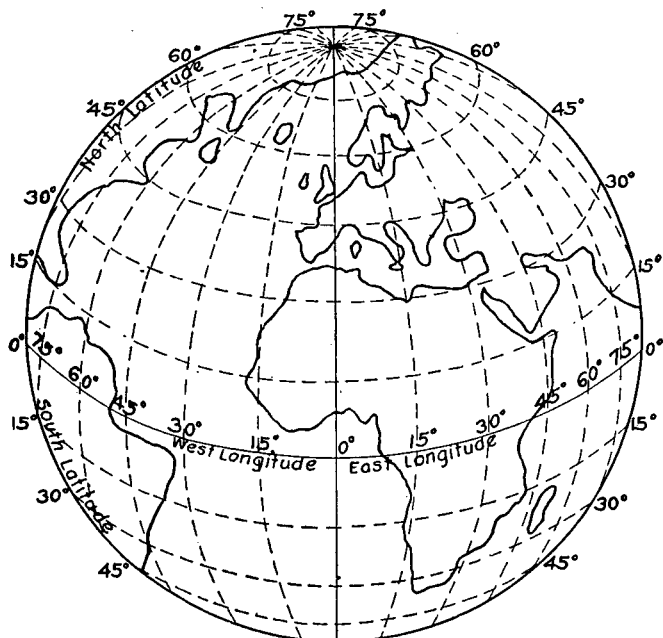

FIGURE 1.—Globe showing meridians and parallels.

divides the earth into the Northern and Southern Hemispheres.

b. Latitude and longitude.—Latitude is expressed by the number of degrees north or south of the Equator, the Equator being 0° and the poles 90° . Points in the Northern Hemisphere have north latitude and in the Southern Hemisphere, south latitude. The meridian of longitude through the

Greenwich Observatory, London, England, has been adopted as 0°. Longitude is measured east or west of the Greenwich meridian to 180°. All points in North and South America have west longitude. (See fig. 1.)

c. Projection.—A map is a representation of a portion of the earth's surface on a plane, and since the earth is a spheroid whose surface is incapable of development as a plane, it is obvious that a map cannot depict a portion of the earth's surface exactly. It is customary in constructing maps to project the portion of the earth's surface under consideration to a surface which is capable of being developed into a plane. A system of developed lines designed for the purpose of constructing a map on a plane surface is called a projection. There have been many kinds of projections devised, all of which may be classified either as equal area, conformal, azimuthal, perspective, or some compromise between these. For further explanation of projection, see TM 5-230.

d. Mercator's projection.—There are several projections based upon a cylinder tangent to the earth along the Equator. That invented by Mercator and known by his name has the latitude scale distorted to equal the stretching in longitude that takes place in developing the sphere upon the cylinder. This distortion is zero at the Equator and infinite at the poles. Due to the rapid distortion when nearing the poles, Arctic land areas such as Greenland are greatly out of proportion. Mercator's projection is used in instrumental navigation, and is the standard projection for hydrographic charts (U. S. Navy), Navy air navigation charts, and Army long distance air navigation charts of small scale.

e. Polyconic projection (fig. 2).—The system adopted for the production of military maps is known as the polyconic projection. On the polyconic projection each parallel of latitude is the developed base of a right cone tangent to the spheroid along that parallel of latitude. Each parallel therefore is a circle whose radius is an element of its tangent cone and whose center is on the axis of the spheroid prolonged. Therefore the radii of no two parallels of latitude, north or south, can be the same. They actually vary between a point at the pole to infinity at the Equator. The result is that parallels of latitude on a polyconic projection are equally spaced along the central meridian of the projection (map),

but this spacing increases rapidly toward the east and west edges. The north-south distortion consequent to this would be prohibitive for military maps on wide projections. In order to avoid this, it is customary to lay out a separate projection for the construction of each standard map sheet, using the central meridian of the map as the central meridian of the projection so that the error or distortion of the projection is limited to the width of a single sheet, in which it is infinitesimal. From this description, it is clear that the characteristics of the polyconic projection are true distances along its parallels of latitude, true distances along its central meridian, and exaggerated distances along all other longitude lines, increasing with the distance toward the east and west edges. Within a projection the size of the United States, the distortion along the Pacific coast would be around 20 percent in a north-south direction.

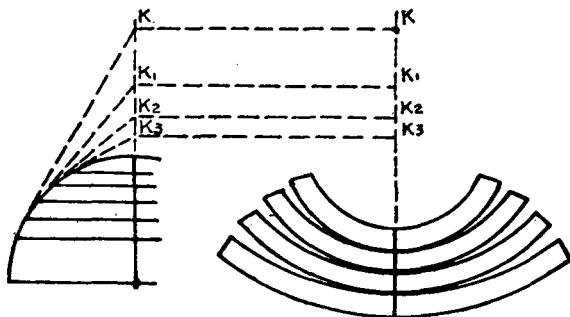

FIGURE 2.—Development of polyconic projection.

■ 5. CLASSIFICATION OF MAPS.—*a. General.*—AR 300-15 prescribes the classification of maps and the specifications for their preparation. Maps used in the theater of operations will consist of those available at the outbreak of hostilities and of those produced thereafter. These maps vary from crude, small-scale planimetric maps to accurate, large-scale topographic maps, and may include various special purpose maps, such as road maps, railroad maps, aeronautical charts, etc. Only in stabilized situations or in a few isolated areas will large-scale maps suitable for tactical operations of small units be found.

b. Types.—Military maps are classified generally according to scale. The general types are—

(1) *Small.*—Maps of small scale varying from 1: 1,000,000 to 1: 7,000,000 are needed for general planning and for strategical studies by the commanders of large units. Various types of general maps are employed for these purposes.

(2) *Intermediate.*—Maps of intermediate scale, normally from 1: 200,000 to 1: 500,000, are required for planning operations, including movements, concentration, and supply of troops. The "Strategic Map of the United States," 1: 500,000, is designed for these uses. Maps of a scale of about 1: 250,000 are particularly applicable to movements of armored forces and as maps of maneuver areas.

(3) *Medium.*—Maps of medium scale, normally from 1: 50,000 to 1: 125,000, are needed for strategical, tactical, and administrative studies by units ranging in size from the corps to the regiment. The United States Geological Survey map, scale 1: 62,500, with wooded areas and road classifications added, has been found suitable for these purposes. This scale is used by the War Department for map production in strategic areas. While not suitable for all purposes, the scale of 1: 62,500 has been found to be the most advantageous for recording topographic detail for future use. During campaign, these maps may be used at this scale or they may be enlarged or reduced according to existing areas.

(4) *Large.*—Maps of large scale, normally not greater than 1: 20,000, are intended for the tactical and technical battle needs of the Field Artillery and of the Infantry. The battle map or map substitute will be furnished for these purposes.

c. Reference.—For a detailed classification of maps by type, see FM 30-20.

■ 6. TRAINING WITH MAPS.—*a. Varied use.*—Any project or operation which involves coordination of movement and employment of groups of men and equipment requires use of a map or map substitute. In peacetime, this may be a sketch indicating a meeting place for a hunting party or an elaborate map of a major railroad system. No organization, with the exception of those involving transportation, utilizes maps more than military forces; and if the variety of types of maps is considered, even the above exception would not apply.

b. Military use.—All arms and services will have occasions to use maps and map substitutes in their respective operations. Modern methods of transportation and warfare demand rapid interpretation of maps by personnel of all units. Lack of time for study in the field necessitates thorough aptitude in map and aerial photograph reading, and the consequent ability to obtain hastily a clear picture of areas represented.

c. Aerial photographs.—Ability to read aerial photographs is required of all military personnel. Usually the nearest thing to a large-scale map in any theater of operations will be aerial photographs in some form. Aerial photographs made under war conditions cannot be expected to depict clearly certain obvious information that is shown in manuals for training in use of aerial photographs. Lack of familiarity with aerial photographs will leave a unit commander with little or no knowledge of valuable information upon which he must make his estimate of the situation.

d. Types of maps used in training.—Equipment used in training should be identical with that used in combat. Nevertheless many troop commanders have been extremely reluctant to use anything except large-scale finished maps in conducting operations. Many junior officers and men become slaves to color maps and contour lines. Initial operations may be with maps of scale 1:200,000 to 1:500,000, or even road maps. The next map available will be some form of photomap, probably a lithographic reproduction of a controlled or uncontrolled mosaic. The large-scale map can be expected only in stabilized situations or for limited areas. The emphasis in training must be placed on such maps, photomaps, or other air photographs as will be available in war. For map restrictions governing training activities, see section IX, FM 30-20.

e. Training in use of maps.—Training in the use of maps and aerial photographs should be planned to include both classroom and field work. The amount of each type of training depends upon the thoroughness contemplated and the size of class. For a small group to receive instruction in the most elementary map and aerial photograph reading, the training should consist of practically all field work. With larger classes and more advanced training, the proportional amount of classroom work increases. In the class-

room, written texts may be used in conjunction with moving pictures (TF-12) or film strips. Film strips with accompanying scripts on map reading (film strip 5-1) and on aerial photography (film strip 5-2) to be shown in 35-mm projectors may be obtained through the corps area or through the Chief Signal Officer, Washington, D. C. FM 21-6 should be consulted to determine what other new publications and aids to training have been prepared or revised in planning any course of instruction.

■ 7. CONVENTIONAL SIGNS.—Conventional signs must be learned just as new words are learned. FM 21-30 or FM 21-25 should be consulted and the conventional signs associated mentally with the objects which they represent.

a. *Authorized symbols.*—Data are shown on standard and special maps as far as practicable by means of the conventional symbols and type prescribed in FM 21-30. Explanation of the meaning of special symbols should appear in marginal notes.

b. *Size of symbols.*—In general, symbols resemble the objects which they represent and vary in size with the scale of the map. On small-scale maps, comparatively few objects can be represented and the symbols are reduced to their most elementary form. As the scale is increased, more objects can be represented and more of the symbols can be drawn to the relative shape and size of the object represented.

c. *Lettering (type).*—The relative size and importance of the feature named are indicated by the size of the type and by the use of capitals and of lower case letters with capital initials. Vertical roman type indicates civil divisions; slant roman type, natural water features; vertical gothic, natural land features; and slant gothic, works of man. Lettering is arranged to be read by the map user from a position at the bottom of the map (south border) or from the right-hand side (east border) since north is usually at the top of the map.

d. *Color scheme.*—Certain maps may appear in five colors:

- (1) Black for the works of man and for the grid.
- (2) Brown for contours.
- (3) Blue for water and water-covered swamps.
- (4) Green for woods and other vegetation.
- (5) Red to indicate road information.

■ 8. MARGINAL INFORMATION.—Maps published by the Army and by other Government agencies show along the margin certain information which is of aid in filing the maps, in interpreting them, and in determining their accuracy. The data listed below are usually printed on the margins of all such maps. (See FM 21-30.)

a. Geographic index number of the map and the location in the geographic index of the quadrangle shown on the map sheet. Directions concerning the use of the geographic index system are contained in AR 300-15.

b. Descriptive title, giving the name of the State or States within which the area represented is located and the name of the area or the map quadrangle.

c. Representative fraction of the map and three graphical scales, one in feet or yards, one in meters, and one in miles. (Only one graphical scale is required on maps not intended for lithographing.)

d. True meridian, magnetic meridian (and variation with date and rate of change), and grid meridian.

e. An explanation of any symbol used which is not prescribed in FM 21-30.

f. Contour interval, when contoured.

g. Name of organization which reproduced map.

h. Date of reproduction or revision.

i. Names of organizations executing the surveys and topography upon which the map is based and date of their execution. If the map has been compiled from other maps, source of compilation is also shown.

j. Name of projection used.

k. Horizontal datum. (If no horizontal datum is given, the latitude and longitude of at least one point shown on the map and easily identified on the ground and the method of its determination should be given.)

l. Vertical datum.

m. Zone and system of military grid. Assume continental system if no reference to system is given.

n. If the area represented lies in the overlap of two grid zones, a reference to the grid of the second zone.

o. Designations of the geographic grid lines. These may be ticks only or both ticks and crosses.

p. Designations of military grid lines.

q. Names of adjoining map sheets.

r. An index of adjoining map sheets.

s. Name designation.

NOTE.—Frequently maps are prepared for temporary or local uses and are not intended to be included in any mapping system. Such maps may be encountered by students at service schools or by those pursuing extension courses. Much of the above listed marginal information is not required on such maps and is therefore omitted. This is true of the Gettysburg map used at the Command and General Staff School, which bears a local grid system with its projection based on the town of Gettysburg.

■ 9. GOVERNMENT MAPPING AGENCIES.—In addition to the maps described in paragraph 5, which are published by the War Department and by the United States Geological Survey and which have been adopted as standard for use of the military forces, maps are issued by various Government agencies as follows:

a. *Soil survey maps*.—These maps are published by the Department of Agriculture on the scale of 1 inch equals 1 mile. They show roads, drainage, towns, and, by symbols and colors, the various classes of soils within the area.

b. *Post route maps*.—These maps are made by the Post Office Department for the designation of postal routes and are primarily for internal administration in that department.

c. *Coast and Geodetic Survey charts*.—These charts are intended for the use of navigators on the coast and are published on various scales ranging from 1:5,000 to 1:40,000 for harbor charts and from 1:80,000 to 1:100,000 for coast charts. They show the depth of the water, aids to navigation, and a narrow strip of topography from 1 to 5 miles in width along the shores.

d. *Lake survey charts*.—These charts are intended for the use of navigators on the Great Lakes and adjacent waters and are published on various scales ranging from 1:5,000 for small harbors to 1:1,200,000 for the general chart of all the lakes. The charts likewise show the depth of the water, aids to navigation, and a narrow strip of topography from 1 to 5 miles in width along the shores.

e. *General Land Office maps*.—Maps of this bureau are comprised of the following: *Township plots* showing land division and area of tracts; *maps of States* having public land showing land survey lines and United States reservations; *general maps of the United States* showing sources of obtaining land, civil and public land boundaries, and progress of land surveys.

f. International Boundary Commission: United States and Canada.—These maps cover a strip of territory from $\frac{1}{2}$ to $2\frac{1}{2}$ miles in width on each side of the boundary between the United States and Canada, from the Arctic Ocean to Mount St. Elias, from the Pacific Ocean to Lake Superior, and from the head of the St. Lawrence River to the Atlantic Ocean. From Mount St. Elias to Cape Muzon, the boundary maps include practically all the territory between the boundary line and the Pacific Ocean. The scales used are: 1:6,000; 1:12,000, 1:24,000, 1:62,500, and 1:250,000, depending on the locality. The contour intervals range from 5 to 250 feet and the maps are complete in cultural features and relief.

g. United States Forest Service maps.—The United States Forest Service prepares maps of areas included within the national forest boundaries and adjacent thereto. The maps are compiled from all sources, governmental and private, supplemented by United States Forest Service surveys. They are intended primarily for administrative purposes in the United States Forest Service. Besides the topography and culture, they frequently carry detailed classification of vegetation. The publication scales are $\frac{1}{4}$ inch, $\frac{1}{2}$ inch, and 1 inch to the mile.

SECTION II

DISTANCE

■ 10. LINEAR MEASURE.—*a.* In different countries, various units are used to measure distance. In England the mile is used, in France the kilometer, in Russia the verst, etc. In the United States, the English system of miles is generally used although the metric system is sometimes employed. The American military map reader should therefore be familiar with both English and metric linear measure and be able to express any distance in either unit.

b. The common units of English linear measure are—

12 inches = 1 foot

3 feet = 1 yard

1,760 yards = 1 mile

c. The common units of metric linear measure are—

10 millimeters = 1 centimeter

100 centimeters = 1 meter

1,000 meters = 1 kilometer

d. A distance expressed in English units can be changed into metric units or, if it is expressed in metric units, it can be changed into English units by use of the following relations:

1 meter=almost exactly 39.37 inches or 1.094 yards

1 kilometer=about .62 mile or 1,094 yards

Example 1: A distance on the ground measures 3,300 yards. How many meters does it measure? *Solution:* $3,300 \div 1.094 = 3,016$ meters (approximately).

Example 2: A distance on the ground measures 2.5 kilometers. How many miles does it measure? *Solution:* $2.5 \times .62 = 1.55$ miles.

■ 11. SCALES OF MAPS.—Every distance on a map must bear a fixed relation to the corresponding distance on the ground. This fixed relation is called the “scale.” Due to the fact that the rise and fall of the ground cannot be shown on the map except by conventional signs (contours and hachures), distances are always measured and written as horizontal distances except when otherwise stated. The vertical distance due to the rise and fall of the ground is called “elevation.” For the conventional methods of indicating scales, see FM 21-25.

■ 12. METHODS OF DISTANCE MEASUREMENT.—a. *Graphic scale.*—The measurement of distance on a map by means of the graphic scale is discussed in FM 21-25.

b. *By use of map measurer* (fig. 3).—The map measurer is an instrument specially designed for quickly measuring distances or lines on a map. It consists of a dial case, handle, and a small wheel or roller. A moving pointer indicates on the dial the distance traveled by the wheel rolling along the line to be measured. Unless the map measurer is graduated to the particular scale of the map being used, it is necessary to convert the units shown on the dial of the instrument to the required units of ground distance. To measure distance with a map measurer, proceed as follows:

(1) Turn the small roller at the side of the dial case opposite the handle to set indicator of map measurer at zero.

(2) Set the roller at one of the given points and, holding

the handle vertical, roll along the line to be measured to the second point.

(3) Under the pointer, read the distance on the divisions on the dial corresponding to the RF of the map.

(4) When there is no scale corresponding to the RF of the map, read the one marked 1: 10,000 and multiply by the denominator of the RF divided by 10,000.

(5) Some dials are divided to read the map distance in inches or centimeters. In this case convert as directed in c (4) and (5) below.

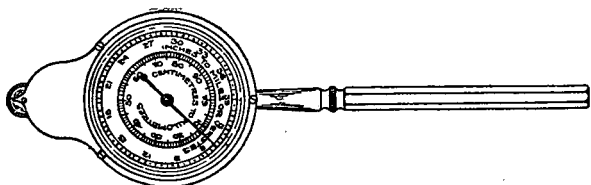

FIGURE 3.—Map measurer.

c. By use of representative fraction and engineer's scale.—

The measurement of distance by means of a linear scale necessitates the conversion of the distance (in inches) on the map to the desired units on the ground. On maps of standard scales this is usually done by means of the representative fraction. In order to facilitate the computations which are involved, an engineer's scale should be selected because such a scale is subdivided in accordance with the decimal system. The measurement of the distance between two points on a map is made by proceeding as follows (fig. 4):

(1) Select the edge of the engineer's scale marked 10 (that is, subdivided into tenths of an inch).

(2) Lay the edge on the two points and slide until the zero coincides with one point.

(3) Read the distance on the scale in inches, tenths, and hundredths opposite the other point.

(4) Multiply this distance by the denominator of the representative fraction. This will give the number of inches on the ground between the two points.

(5) To secure the distance in feet, yards, or miles, divide by 12 for feet, 36 for yards, or 63,360 for miles.

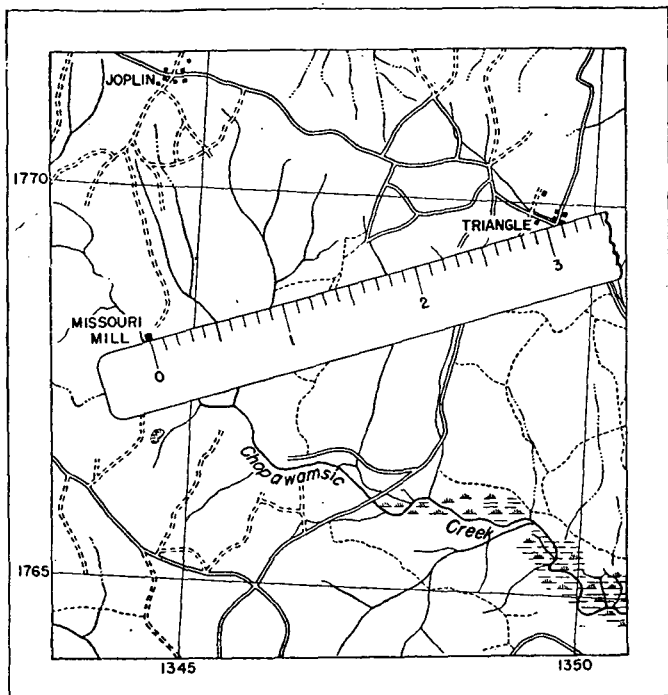

FIGURE 4.—Measurement of distance on a map by means of an engineer's scale.

(6) When the denominator of the representative fraction is the same as the number stamped on the middle of an edge of the engineer's scale, or is that number with additional ciphers, the ground distance in inches may be read directly on this edge of the scale, giving careful attention to correct placing of the decimal point.

(7) To measure an irregular line such as a road or stream, divide it into approximately straight sections. Measure each as indicated above. The sum is the required distance.

Example: Figure 4 shows a portion of a map to a scale of 1: 62,500. It is desired to find the distance on the ground between MISSOURI MILL and the road junction at TRIANGLE. Lay the edge of the engineer's scale divided

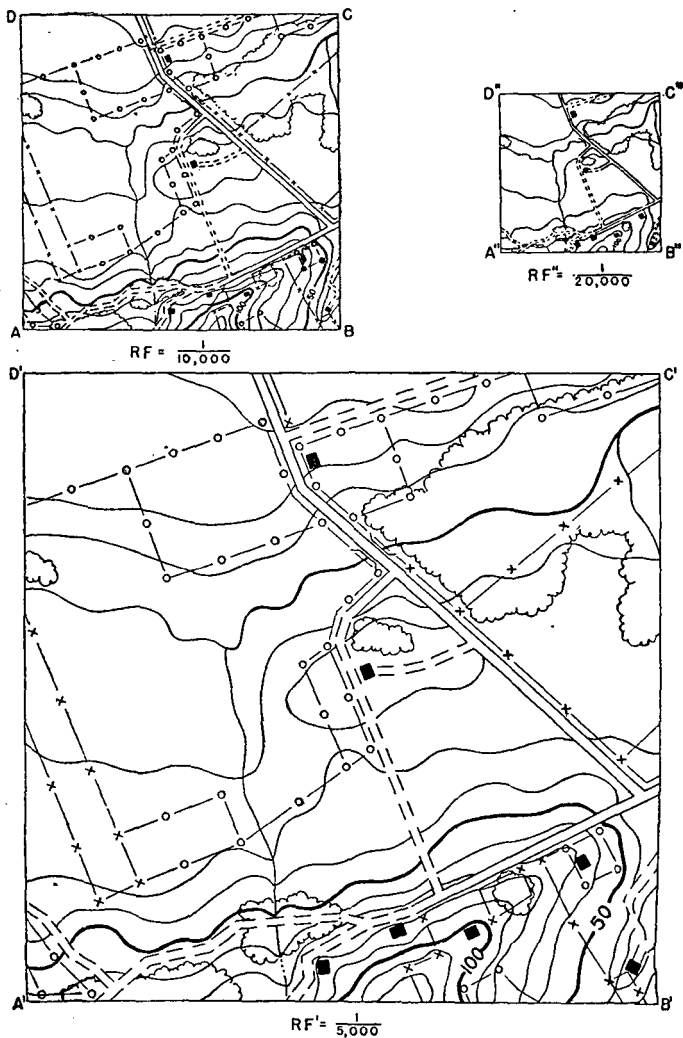

FIGURE 5.—Relation between distances and areas on maps of different scale. (Scales of maps shown above have been reduced in printing.)

into tenths of an inch along the two points. It may be seen that the map distance is 3.07 inches. The distance on the ground is 3.07 times 62,500 or 191,875 inches. This is 15,990 feet or 5,330 yards or 3.03 miles.

■ 13. RELATION BETWEEN DISTANCES AND AREAS ON MAPS OF DIFFERENT SCALE.—Figure 5 shows at a reduced scale an identical area of ground represented on maps of three different scales; that is, 1:5,000, 1:10,000, and 1:20,000. $A, B, C,$ and D are points on the ground. $A'B'$ on a map of scale 1:5,000 is just twice as long as AB on a map of scale 1:10,000. The area of the map $A'B'C'D'$ at scale 1:5,000 is just four times the size of the same area at scale 1:10,000. Conversely, $A''B''$ on a map of scale 1:20,000 is just one-half as long as AB on a map of scale 1:10,000 and the area $A''B''C''D''$ is one-fourth the size of $ABCD$. These relationships may be stated as follows:

a. Distances.—Distances on different maps vary directly as the representative fractions of the maps and inversely as the denominators of their respective fractions, thus (fig. 5):

$$\frac{AB}{A'B'} = \frac{RF}{RF'} = \frac{\frac{1}{10,000}}{\frac{1}{5,000}} = \frac{5,000}{10,000} = \frac{1}{2}$$

b. Areas.—Areas on different maps vary directly as the squares of the representative fractions of the maps and inversely as the squares of the denominators of their respective fractions, thus (fig. 5):

$$\frac{ABCD}{A'B'C'D'} = \frac{(RF)^2}{(RF')^2} = \frac{\left(\frac{1}{10,000}\right)^2}{\left(\frac{1}{5,000}\right)^2} = \frac{(5,000)^2}{(10,000)^2} = \frac{1}{4}$$

■ 14. DETERMINATION OF SCALE OF MAP AND CONSTRUCTION OF GRAPHIC SCALE.—It is important that the user of a map be able to determine the RF of a map when in the field and readily construct a suitable graphic scale for use in the event that the scale data are missing from the map. The procedure is as follows:

a. Determination of scale.—The scale of a map may be determined from known distance on the ground, or from scaled distance on another map of known scale.

(1) *By measurement of distance between two points on ground.*—(a) Locate two objects on the ground which can be identified on the map, such as bridges, houses, etc.

(b) Estimate, stride, or measure on the ground in some manner, the distance between the selected points, and convert into inches. (The method of measuring should depend on accuracy required, time available, etc.)

(c) Measure in inches the distance on the map between the two points selected.

(d) Determine the scale from the relation—

$$\text{R.F.} = \frac{\text{distance on map in inches}}{\text{distance on ground in inches}}$$

This expression, when reduced to a fraction the numerator of which is unity, becomes

$$\text{R.F.} = \frac{1}{\left(\frac{\text{distance on ground in inches}}{\text{distance on map in inches}} \right)}$$

NOTE.—Distances may be expressed in any unit of measurement provided the same is used for both map and ground distances.

Example: Map distance between two points=3 inches; ground distance between corresponding points=5,208.3 yards.

$$\text{R.F.} = \frac{1}{\left(\frac{5,208.3 \times 36 \text{ inches}}{3 \text{ inches}} \right)} = \frac{1}{62,500}$$

(2) *By measurement between two points on map of known scale.*—(a) Locate two objects on map of known scale which can be identified on the map the scale of which is to be determined.

(b) Scale from both maps the distances between the points in the same unit of measurement (inches).

(c) Determine the scale of the map by one of the two methods given below:

1. Convert distance on map of known scale to distance on the ground, and solve as in (1) above.
2. Determine scale from the relation—

$$\frac{\text{R.F. of the map}}{\text{R.F. of map of known scale}} = \frac{\text{distance on the map}}{\text{distance on the map of known scale}}$$

Example: Distance between two points on the map of unknown scale=8 inches.

Distance between corresponding points on a map of 1:20,000 scale=4 inches.

$$\frac{\text{RF}}{1} = \frac{8}{20,000}$$

$$\text{RF} = \frac{8}{4} \times \frac{1}{20,000} = \frac{1}{20,000 \times \left(\frac{4}{8}\right)} = \frac{1}{10,000}$$

It is seen from the above that the denominator of the RF of the map (10,000) is obtained by multiplying the denominator of the RF of the map of known scale (20,000) by the distance measured on that map (4) and dividing by the distance measured on the map the scale of which is sought (8).

b. To construct scale (fig. 6).—(1) Suppose it is desired to construct a graphic scale to read to 1,000 yards for use on a map whose RF has been determined as 1:10,000. The procedure is as follows:

(a) 1,000 yards on the ground=36,000 inches. 36,000 inches at scale 1:10,000= $\frac{36,000}{10,000}$ =3.6 inches on map, or since 1 inch on the map=10,000 inches on the ground, then 36,000 inches on the ground= $\frac{36,000}{10,000}$ =3.6 inches on the map.

(b) Lay off the line *ab* (fig. 6)=3.6 inches, using the engineer's scale.

(c) Lay off at any acute angle the line *ab'* representing 10 convenient equal divisions of the engineer's scale. Draw the line *bb'* and through each division of the line *ab'* draw lines parallel to *bb'*, to cut the line *ab*, dividing it into 10 equal parts of 100 yards each. Use the left division as the scale extension and further subdivide it in a similar manner into five equal parts of 20 yards each. Mark the graduation as shown in the figure. Show the RF of the scale and the linear unit represented by it.

(2) Another method not so accurate as the above but simpler and quite satisfactory for practical purposes is to compute the length of one 100-yard graduation (or any other suitable division) of the primary scale and then apply that as many times as necessary along a line, as *ab* in figure 6. For example, in the case of the map whose RF was determined as

1:2,769, the length of a 100-yard interval of the scale would be $\frac{3,600}{2,769} = 1.3$ inches, approximately. Point off this distance as many times as 100-yard graduations are required for the primary scale, subdividing the left interval as the extension.

■ 15. TIME-DISTANCE SCALES.—In solving tactical problems or in planning military operations on maps, time-distance scales frequently prove time-saving devices of great usefulness. A time-distance scale is a scale whose graduations are

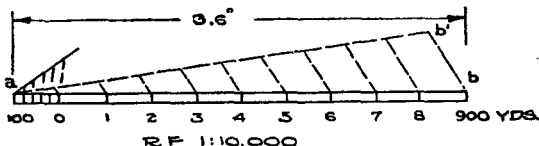

FIGURE 6.—Construction of graphic scale.

time intervals of distance to the scale of the map at a given rate of movement (fig. 7). Suppose that a time-distance scale graduated in hours and minutes of time at a given marching rate, is desired for use on a topographic map 1:62,500. To construct such a scale, the procedure is as follows:

a. (1) In 1 hour, infantry marches $2\frac{1}{2}$ miles or $2\frac{1}{2} \times 63,360 = 158,400$ inches.

(2) 158,400 inches on the ground = $\frac{158,400}{62,500} = 2.53$ inches on

a map whose scale is 1:62,500.

(3) On a suitable strip of paper along a straight line ab (fig. 7), lay off as many 1-hour intervals of 2.53 inches each as may be desired in the scale. Subdivide the left interval on the scale extension into 1-minute, 5-minute (used in fig. 7), or 10-minute graduations, depending on the least reading desired; mark the graduations appropriately. On the scale, indicate the R.F. of the map to which the scale applies and the marching rate to which constructed.

b. (1) In 1 hour, cavalry marches 5 miles or $5 \times 63,360 = 316,800$ inches.

(2) 316,800 inches on the ground = $\frac{316,800}{62,500} = 5.07$ inches.

The construction of the scale is similar to that described and illustrated in figure 7.

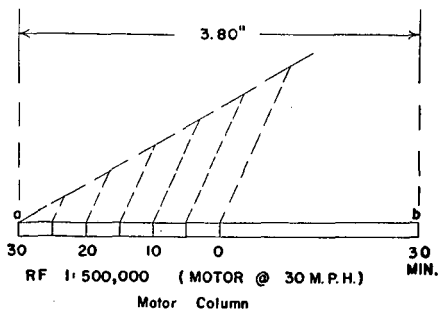
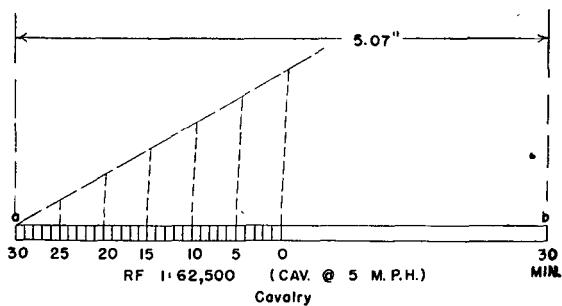
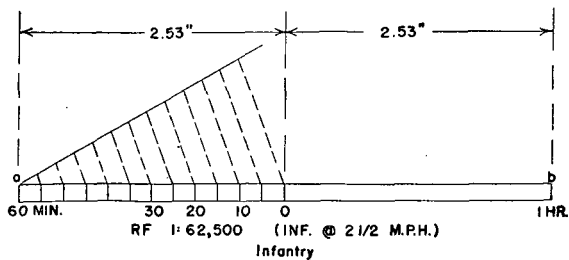

FIGURE 7.—Time-distance scales.

c. (1) In 1 hour, a motor column marches 30 miles or $30 \times 63,360 = 1,900,800$ inches.

(2) 1,900,800 inches on the ground = $\frac{1,900,800}{62,500} = 30.41$ inches on the map.

This shows why operations for units with such rates of march would ordinarily be planned on smaller scale maps. Hence the time-distance scale for a motor column is shown in figure 7 for a 1:500,000 map, making a 1-hour march equal 3.80 inches on the map.

SECTION III

DIRECTION, ORIENTATION, AND LOCATION

■ 16. **DIRECTION ANGLES.**—Distance and direction may be used to locate a point or object on the ground or on a map with respect to an occupied or known point. The distance may be measured, paced, or estimated, depending upon the required degree of accuracy. For military purposes direction is always expressed in terms of an angle from some fixed or easily established base direction line.

■ 17. **UNITS OF ANGULAR MEASUREMENT.**—The value of an angle may be expressed in degrees, minutes, and seconds; or in mils.

a. *Degrees, minutes, and seconds.*

A circle = 360°

1° = 60 minutes.

1 minute = 60 seconds.

b. *Mils.*—A mil is the angle subtended by an arc of 1 unit on a radius of 1,000 units or, in other words, an angle the tangent of which is approximately $1/1,000$. The arbitrary value of the mil adopted by the United States Army is $1/6,400$ of a circle.

c. *Conversion factors.*

$1^\circ = 17.8$ mils approximately.

1 mil = 0.056° approximately.

= 3 minutes 22.2 seconds.

= $0.056 \times$ mils.

Mils = $17.8 \times$ degrees.

■ 18. **BASE DIRECTIONS.**—The characteristics of the three base directions are given in table I.

TABLE I.—*Characteristics of base directions*

Designation	Base	Departure from true north	Variations	When used
True north	True meridian	No departure	No variation	In conjunction with geographic map and for permanent records. NOTE.—All directions are assumed based on true north unless otherwise stated.
Magnetic north	Magnetic meridian	Termed magnetic declination and varies in the United States from 25° east in Washington State to 22° west in Maine.	Annual change has been as much as 6 minutes in some localities.	In conjunction with the magnetic compass in the field.
Grid north	True center meridian of the zone of the grid.	Termed gisement and increases to a maximum of approximately 3° at the edge of the grid zone.	No variation	In conjunction with maps on which the military grid is printed.

■ 19. DECLINATION.—Declination is the difference in direction between true north and either magnetic north or grid north. Hence there are two declinations, magnetic declination and grid declination or gisement.

a. *Magnetic*.—Due to the difference in position between the true and magnetic poles and the inequality of magnetic distribution throughout the earth, there will always be, except in very limited localities, an angle between true north and magnetic north. This angle is called the magnetic declination. When the needle points east of true north, the

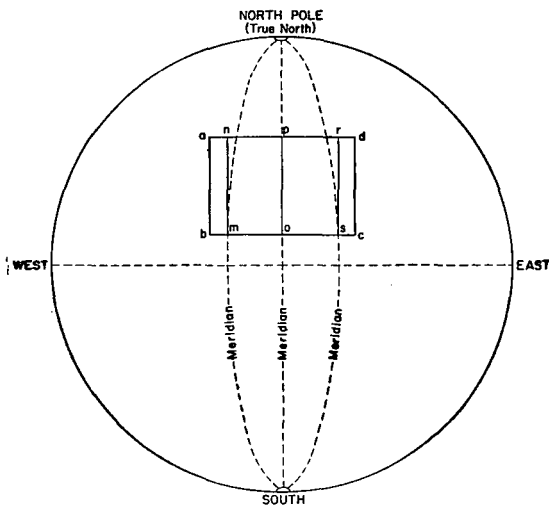

FIGURE 8.—Diagram illustrating reason for grid declination.

magnetic declination is east; when west of true north, the magnetic declination is west. Lines joining points on the surface of the earth where magnetic north and true north are the same direction so that there is no magnetic declination are called agonic lines.

Lines joining points having the same declination are called isogonic lines. The magnetic declination in the United States varies from 25° east in the State of Washington to 22° west in Maine. Isogonic lines run across the United States in a general north and south direction but are very irregular, in some instances doubling back on themselves

(fig. 9). The magnetic declination at any one locality is subject to change, the amount of which can be predicted from past records. This change in some localities in the United States is as much as 4 minutes annually. Magnetic declination and annual magnetic change are shown on maps of the United States published every 5 years by the Coast and Geodetic Survey. Every standard map should show in diagrammatic form the average relation of magnetic and true north for the area of the sheet at a stated date; also the annual magnetic change and whether increasing or decreasing.

b. Grid.—Grid declination is the fixed difference in direction between true north and grid north. Because of the fact that the meridians converge to meet at the pole while all the north-south grid lines (*Y* lines) of the same grid zone are parallel to one another (see par. 34 for an explanation of the military grid system), there is a deviation between true north and grid north except along the central meridian of the grid zone. This deviation is called grid declination or gisement and reaches a maximum of 3° at the edge of the grid zone. It is illustrated in figure 8 which shows a sketch of the projection of the earth with *abcd* representing the area of a map on which the line *op* is the projection of the central meridian of the grid zone. The north-south grid lines are straight lines parallel to *op*. The projections of all meridians other than *op* are curved converging lines which deviate in direction from the direction of the north-south grid lines. This deviation is designated as west grid declination for all points west of the central meridian, as at point *m*, and as east grid declination for all points east of the central meridian, as at point *s*. The declination is determined by finding the angle that the *Y*-grid line makes with true north at the point in question. Although the grid declination varies at different points on a map, this variation on the tactical map is so slight that the average grid declination for the area may be used as the actual grid declination at any point on the map sheet without introducing an appreciable error. Every standard map should show in diagrammatic form the average grid declination for the area represented by the map.

FIGURE 9.—Lines of equal magnetic declination and of equal annual change in United States for 1935.

(For figure see back of manual.)

■ 20. DIRECTION OF ANGULAR MEASUREMENTS.—The characteristics of the methods used to express the direction of angular measurements are given in the following table:

TABLE II.—*Characteristics of methods of expressing directions of angular measurements*

Designation	Units of angular measurement used	Base direction	Direction of measurement
Azimuths.....	Degrees or mills..	True, magnetic, or grid north, unless otherwise stated (south may be used).	Clockwise.
Bearings.....	Degrees.....	True or magnetic north and south; whichever used is designated.	Direction which gives smallest arc (must not exceed 90°) is used and is designated.

For military purpose, directions should normally be expressed as azimuths measured from true, magnetic, or grid north.

■ 21. RELATIONSHIP BETWEEN TRUE, MAGNETIC, AND GRID AZIMUTHS AND BEARINGS.—This relationship is shown in figure 10.

Example:

Line BA:

Azimuth.....	60°.
Magnetic azimuth.....	66°40'.
Grid azimuth.....	57°35'.
Bearing.....	N. 60° E.
Magnetic bearing.....	N. 66°40' E.
Back azimuth.....	240°.

Line AB:

Azimuth.....	240°.
Magnetic azimuth.....	246°40'.
Grid azimuth.....	237°35'.
Bearing.....	S. 60° W.
Magnetic bearing.....	S. 66°40' W.
Back azimuth.....	60°.

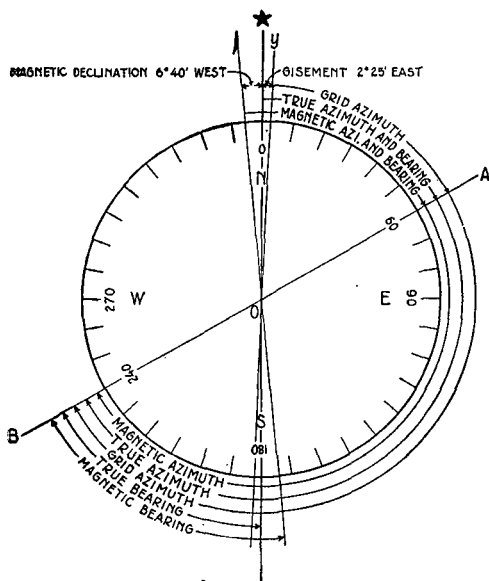

FIGURE 10.—Relationship between true, magnetic, and grid azimuths and bearings.

■ 22. **MAGNETIC COMPASS.**—There are three types of magnetic compasses used by the Army, varying chiefly in scales and sights. Below is a brief description of each; for a more complete description of the compass and its use, see FM 21-25.

a. Watch compass.—The watch compass has a movable needle, a fixed dial graduated in bearings, and has no sighting device.

b. Prismatic compass.—The prismatic compass has a circular magnetic floating dial, prismatic eyepiece, and a north point painted in luminous paint in the case. One of the two dial graduations is read through the prism and the other is read direct. Each scale is graduated from 0° to 360° . The forward sight is a hair line on the glass in the top of the case.

c. Lensatic compass.—The lensatic compass functions in much the same manner as the prismatic compass. It contains a magnifying lens fixed in a hinged eyepiece. The face has two scales, one graduated in degrees, the other in mils.

■ 23. LOCAL MAGNETIC ATTRACTION.—In addition to the compass variation caused by magnetic declination, the magnetic compass is affected by the presence of iron and electrical fields of magnetism. Consequently, great care should be taken not to approach such local magnetic attraction within a distance which will cause the magnetized compass needle to deviate while making observations to determine direction. The rifle, pistol, and helmet must be laid aside when reading the compass. The following are the minimum safe distances for visible masses of iron and electrical fields of magnetism:

	<i>Yards</i>
High tension power lines.....	150
Heavy gun.....	60
Field gun and telegraph wires.....	40
Barbed wire.....	10

■ 24. PROTRACTOR.—*a. Relationship between semicircular and rectangular protractors.*—In figure 11 it will be noted on each protractor that two scales are shown, one reading from 0° to 180° and the other from 180° to 360° . With both scales, each protractor can be used to read the full circle in degrees. Inasmuch as both the semicircular and the rectangular protractors are used in the same manner, the method of using the less familiar type only is given.

b. Use of rectangular protractor (fig. 12).—Assuming the Y-grid lines are available on the map and the angle which magnetic north makes with grid north is shown on the map margin to be the sum of the magnetic declination $6^{\circ}21'$ and gisement $2^{\circ}35'$ or $8^{\circ}56'$, to lay off the magnetic azimuth of a line *AB* the procedure is as follows:

(1) Join the points *A* and *B* by a fine, lightly drawn line and prolong until it crosses the nearest Y-grid line and extends beyond the edges of the protractor.

(2) By inspection, the azimuth is seen to be less than 180° and therefore should be measured on the outside or lesser azimuth circle (0° to 180°) of the protractor with the protractor placed on the east side of the direction line.

(3) Place the protractor along the intersected grid line 65 and shift it until the index coincides with the point where *AB* prolonged crosses the grid line. About this point as a pivot, turn off an angle of $8^{\circ}56'$ (or 9° in practice, since the difference is unmeasurable) counterclockwise. The index

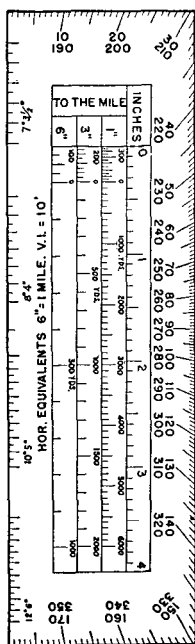

① Rectangular.

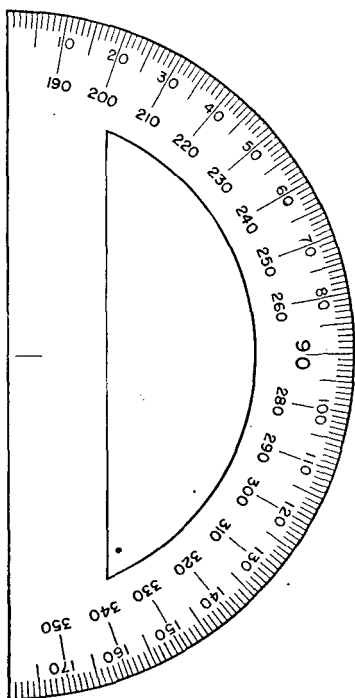

② Semicircular.

FIGURE 11.—Military protractors.

edge of the protractor is now on the magnetic meridian. The value of the azimuth angle sought is read $61^{\circ}00'$ at the point on the outside azimuth "circle," where the line AB prolonged cuts the edge of the protractor.

(4) Suppose, however, the problem is to measure the magnetic azimuth of the line BA , which is the back azimuth of the line AB and differs from it by 180° . By inspection this is seen to be greater than 180° , requiring use of the inner "circle" of graduations (180° to 360°) with the position of the protractor on the opposite side of the grid line. The procedure is similar to that just described except the protractor is placed on the west side of the 65 grid line, the angle $8^{\circ}56'$ is turned off counterclockwise from the south end of the pro-

tractor, and the angle of $241^{\circ}0'$ is read on the inner "circle" where BA prolonged crossed the graduated edge of the protractor.

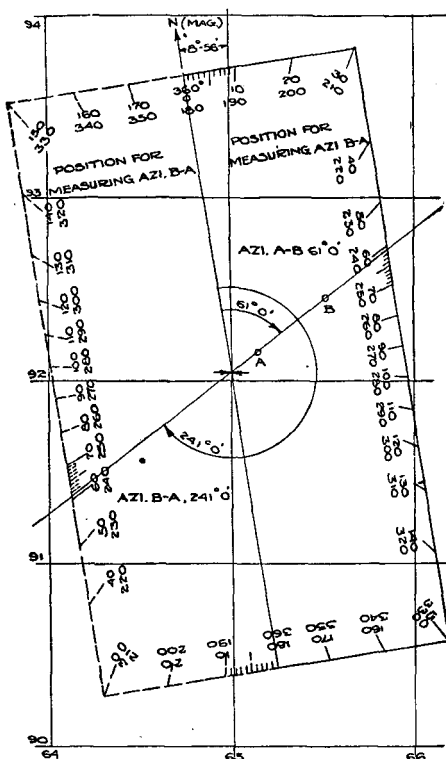

FIGURE 12.—Use of rectangular protractor.

■ 25. DETERMINATION OF DIRECTION BY FIELD EXPEDIENTS.—*a.* *By aid of watch and sun* (fig. 13).—North can be determined with an error of less than 8° if the sun is visible and a watch showing approximately the correct sun time is available. Point the hour hand, watch held face up, at the sun. This is facilitated by casting the shadow of a vertical pencil across the face of the watch and by then bringing the hour hand into this shadow. A line drawn from the center of the dial

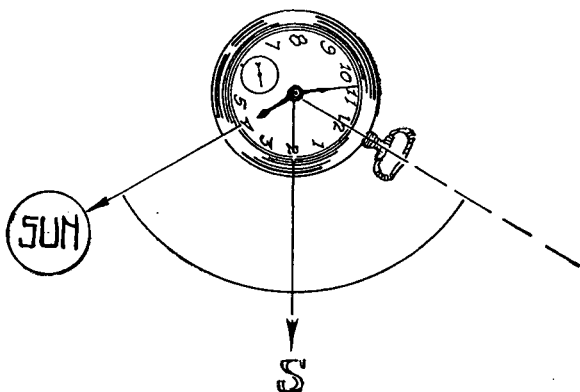

FIGURE 13.—Determination of north by watch and sun.

to a point halfway on the smaller arc between the hour hand and the 12 of the watch will point south. In the Southern Hemisphere the watch must be held face down and this line will point north. This method is difficult to use when the sun is very high in the heavens and is of little or no use in the Tropics.

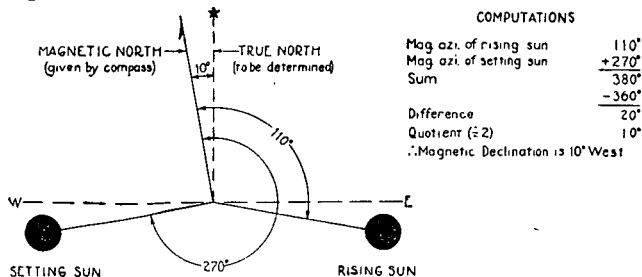

FIGURE 14.—Determination of north by rising and setting of sun.

b. By rising and setting of celestial body (fig. 14).—Observe the magnetic azimuth of the sun, a planet, or a bright star at rising and setting on the same day or at setting on one day and rising the next. Add these two azimuths together. Take the difference between this sum and 360°. One-half of this difference is the declination of your compass—east, if the sum of the azimuths is less than 360°; west, if it is greater.

In using this method the observations are best taken when the object is just above the true horizon, or at a gradient of zero. This can usually be done if a high point is chosen for observation. If this cannot be done, be careful to take both observations with the object at the same gradient, as determined with a clinometer. This is most important with the sun. Under the least favorable conditions an inequality of 1° in the gradients at the time of observation on the sun may introduce an error of $\frac{1}{2}^\circ$ in the result. In using a star, choose one which rises nearly east from the point of observation. If this is done the inequality of a degree in the gradients will be immaterial. Both observations need not be made at the

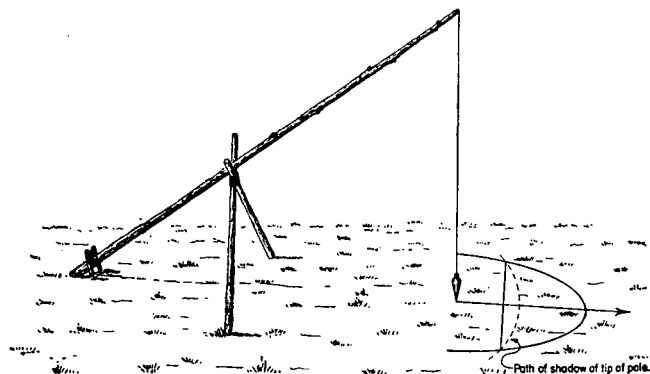

FIGURE 15.—North by sun and plumb line.

same point, but should not be more than 10 miles apart in east and west or north and south directions.

c. By aid of sun and plumb line (fig. 15).—On a level piece of ground, lean a pole toward the north and rest it in a crotch made by two sticks, as shown. Suspend a weight from the end of the pole so that it nearly touches the ground; then, about an hour before noon, attach a string to a peg driven directly under the weight and, with a sharpened stick attached to the other end of the string, describe an arc with a radius equal to the distance from the peg to the shadow of the tip of the pole. Drive a peg on the arc where the shadow of the tip of the pole rested. About an hour after noon, watch the shadow of the tip as it approaches the east-

ern side of the arc and drive another peg where it crosses. By means of a tape or string, find the middle point of the straight line joining the last two pegs mentioned. A straight line joining this middle point and the peg under the weight will, for all practical purposes, be true north.

*d. By means of North Star (Polaris).—*Ursa Major (Big Dipper) shown in the upper portion of figure 16 is the easiest constellation to distinguish and provides the best

MAGNITUDES

★ $1\frac{1}{2}$ to 2nd

★ 2nd to 3rd

◆ 3rd to 4th

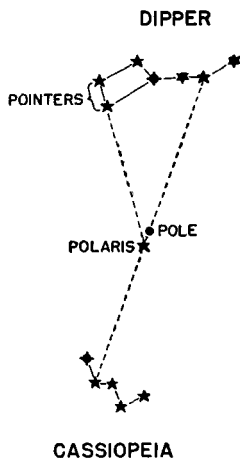

FIGURE 16.—Determination of north by North Star.

means for locating the North Star. The two "pointers," or the stars forming the lip of the dipper, point to the North Star (Polaris) at all times as the Dipper appears to circle the pole. On the opposite side of Polaris and at about the same distance from it is the constellation of Cassiopeia. Its form is that of the letter "W." The great importance which attaches to the North Star is that it is never more than 2° away from the point where the axis of the earth, if extended,

would pierce the heavens. It therefore appears to the eye to be always in the same place. An observation of the North Star to determine true north, when the Dipper and Cassiopeia are above and below the North Star, will give the declination of the compass to within the least reading of the compass.

■ 26. ORIENTATION.—*a. Definition.*—A map is oriented when, in a horizontal position, its north point points north and all lines of the map are parallel to the corresponding lines

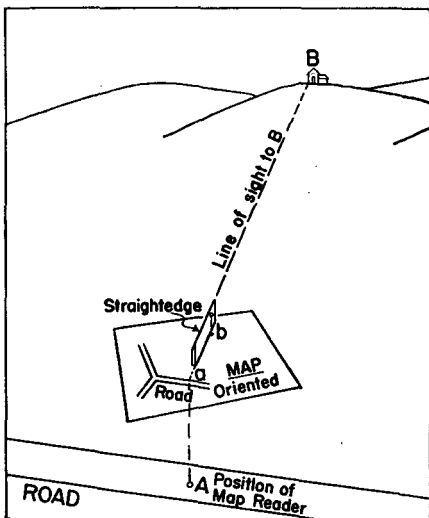

FIGURE 17.—Location of one's position on map by resection when along road (graphic method).

of the ground. A map reader is oriented when he knows his position on an oriented map and the cardinal directions on the ground. A map will be of small use in the field unless its possessor can orient himself readily. It follows that ready command of the simpler methods of practical orientation is of prime importance to the student of map reading.

b. Methods of orientation.—Primary methods of orientation by inspection, with a compass, and by sighting on a distant point (given in FM 21-25) should be known to ad-

vanced students and are not repeated here. Several methods of orientation by resection are given below.

c. Location of one's position along road or similar feature by resection.—The position may be determined graphically or may be plotted by means of a protractor after a compass has been used to give direction. The first method is the speedier and is most commonly employed when the determination of position is undertaken in the field.

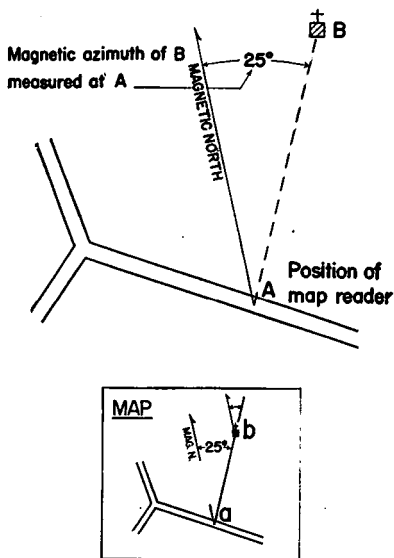

NOTE: Map need not be oriented

FIGURE 18.—Location of one's position on map by resection when along road, using compass and protractor.

(1) *Graphic method* (fig. 17).—Proceed as follows:

(a) Identify a convenient visible object *B* on the ground which appears on the map at *b*.

(b) Rest the map in a horizontal position on some nearby convenient support, such as a fence post, stone, or fold in the terrain, from which *B* is visible, and set a pin in the map at *b*.

(c) Orient the map.

(d) Without moving the map, hold a straightedge against the pin at *b* and align its edge with the object *B* on the terrain.

(e) Draw a line through *b* along the straightedge and prolong it to intersection with the road at *a*. This intersection is the point sought.

(2) *By means of compass and protractor* (fig. 18).—Proceed as follows:

(a) Identify a convenient visible object *B* on the ground whose position *b* appears on the map.

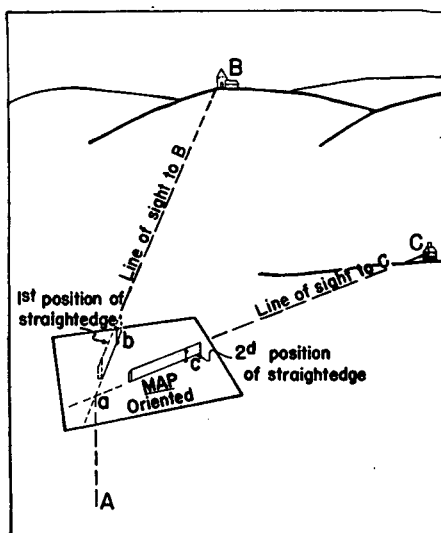

FIGURE 19.—Location of one's position on map by resection from two distant points (graphic method).

(b) With the compass, sight *B* and read the magnetic azimuth.

(c) On the map with the protractor lay off this azimuth through *b* and prolong the line until it intersects the road at *a*, which is the position sought.

NOTE.—When azimuths are read from observer to a known position, either the azimuth or back azimuth may be used in plotting the direction line through the known position.

d. Location of one's position by resection from two distant points.—This method of locating a position is useful when no well-defined feature, such as a road, is in the vicinity. The position may be determined graphically or may be plotted by means of a protractor after directions have been read by a compass. The first method is speedier and is most commonly employed when the determination of position is undertaken in the field.

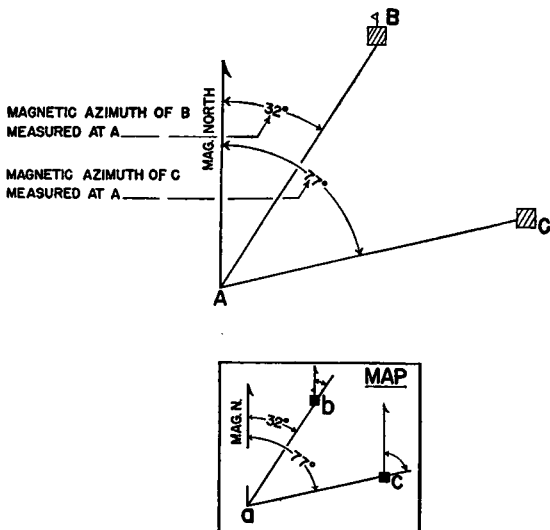

NOTE: Map need not be oriented

FIGURE 20.—Location of one's position on map by resection from two distant points, using compass and protractor.

(1) *Graphic method* (fig. 19).—Proceed as follows:

(a) Select two visible objects on the terrain, as *B* and *C*, whose positions *b* and *c* appear on the map, so situated that lines radiating from observer to objects form an angle of 30° to 150° at the observer.

(b) Rest the map in a horizontal position on some nearby convenient support, such as a fence post, stone, or convenient fold in the terrain, from which the objects *B* and *C* on the terrain are visible and set pins through their respective map positions, *b* and *c*.

(c) In this position, orient the map.

(d) Without moving the map, sight *B* and *C* successively on the terrain along a straightedge held against the pins through the corresponding points *b* and *c*, respectively. Along the straightedge, draw lines through *b* and *c* and prolong these lines to intersection at *a*, which is the point sought.

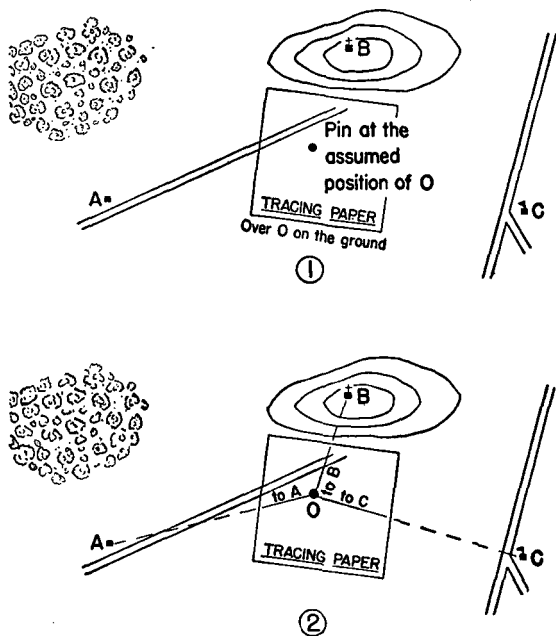

FIGURE 21.—Location of one's position on a map by resection from three distant points (tracing paper method).

(2) *By means of compass and protractor* (fig. 20).—Proceed as follows:

(a) Select two visible objects on the terrain, as *B* and *C*, the positions of which, *b* and *c*, can be identified on the map and which are so situated that lines radiating from observer to object make an angle of 30° to 150° at the observer.

(b) With the compass sight the objects on the landscape successively, reading the magnetic azimuth to each.

(c) Draw magnetic north guide lines through the map position of each object, *b* and *c*, and with the protractor lay off the respective magnetic azimuths.

(d) Prolong the azimuth lines through the points *b* and *c* until they intersect.

(e) The intersection of these lines at *a* is the map position sought.

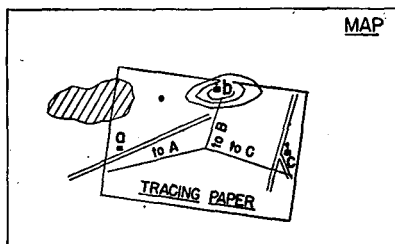

③

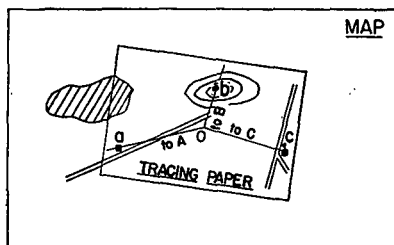

④

FIGURE 21.—Location of one's position on a map by resection from three distant points (tracing paper method)—Continued.

*e. Location of one's position by resection from three distant points (tracing paper method) (fig. 21).—*This method is useful on unoriented maps when the observer is without a compass in indefinite terrain of which only distant prominent features are recognizable or when local attraction due to presence of ore bodies or other material renders the magnetic needle useless.

(1) Select three visible objects on the terrain such as *A*, *B*, and *C*, so distributed that radial lines drawn from observer to each point will yield good angles of intersection (about 30° to 150°) at *O*, the position occupied by the observer (fig. 21①).

(2) Place a piece of tracing paper on a flat surface, supported on a convenient fence post, rock, or on the ground,

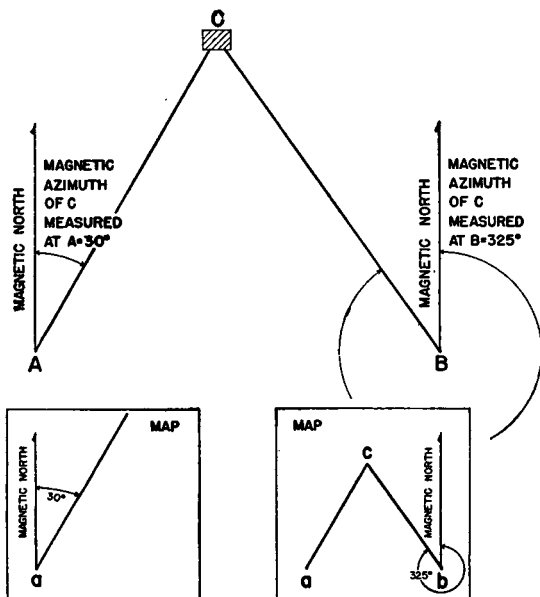

Note: Map need not be oriented

FIGURE 22.—Location on map of distant point by intersection, using compass and protractor.

and set a pin in it at any convenient assumed position of the observer at *O*.

(3) Place any suitable straightedge against the pin, sight along its edge successively to each object, *A*, *B*, and *C*, on the terrain and draw radial lines along the straightedge toward each object (fig. 21②).

(4) Remove the tracing paper and superimpose it over the map (fig. 21③), shifting it about until the three radial

lines pass through the conventional signs *a*, *b*, and *c* on the map which correspond to the three objects sighted on the ground (fig. 21④).

(5) In this position, prick the map through the original pinhole *o* on the tracing. The point thus located on the map is the position of the map reader.

■ 27. LOCATION OF DISTANT POINT BY INTERSECTION.—*a. With compass and protractor.*—It is frequently desirable to locate or post on a map distant or inaccessible objects on the terrain

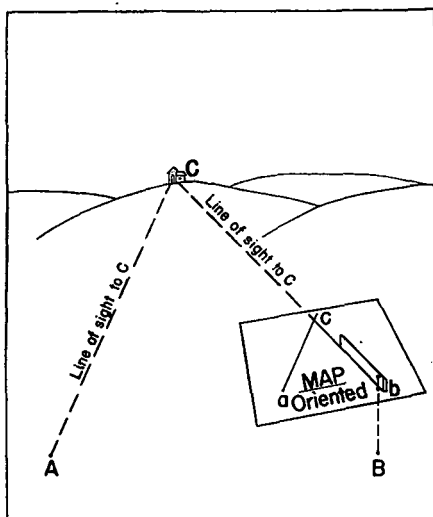

FIGURE 23.—Location on map of distant point by intersection (graphic method).

which do not appear on the map in hand. This may be conveniently done by intersecting lines from two occupied points of known position on the map. Assume that the location of an object *C* shown in figure 22 is desired on a map. In order to locate the position of *C*, one must occupy successively two positions, such as *A* and *B*, from which the object *C* is visible and read the magnetic azimuth of *C* from *A* and *B*, respectively. By aid of a protractor, these azimuths are plotted through the corresponding positions *a* and *b* on the map.

The direction lines prolonged will intersect at *c* on the map, the position sought. Many points may be thus located on the map from two occupied positions.

b. Graphic method (fig. 23).—The observer occupies in succession the positions *A* and *B* on the ground. In each position he rests the map horizontally on some nearby convenient support and sets a pin in the corresponding map positions *a* and *b*, respectively. In each position the map may be oriented with a compass, by inspection, or by alining the positions *a* and *b* on the map with the corresponding objects *A* and *B* on the ground. The last method is the most accurate. At each occupied position a straightedge is placed against the pin in the corresponding position on the oriented map, the object *C*, the position of which is sought, is sighted along the straightedge and a direction line drawn thereto. This results in two such direction lines, one from each occupied position, the intersection of which gives the map position *c* of the object *C*. The results may be checked by a direction line from a third position of the observer.

■ 28. TRAVERSE.—*a.* A series of lines of known distance and direction is called a traverse. An approach route to an assembly area, designated with distances and directions from point to point, would form a traverse.

b. In locating on the terrain objects which do not appear on the map and which cannot be intersected, or in exploring unfamiliar terrain equipped with a compass, the method of traversing is useful. This consists of starting from a known point and following observed compass courses from point to point, measuring distances. These course lines and distances, when plotted to scale on the map, show graphically the course followed and the map location of any desired point on the traverse. Where the distance to the point sought is great and the intervening terrain is rough, it is not practicable to attempt its location by means of a simple straight course. In such cases the traverse would consist of a meander of many straight course lines and angles making changes of direction as influenced by the intervening terrain but ultimately terminating at the point sought. Scouts use this method in registering on a map the route they follow.

SECTION IV
COORDINATES

■ 29. SYSTEMS OF COORDINATES.—*a.* In order to express absolute or relative positions of points, either on a map or on the terrain, one or more of four different systems of coordinates may be selected. Each system has its appropriate use. The names of these systems are as follows:

- (1) Polar coordinates.
- (2) Rectangular coordinates.

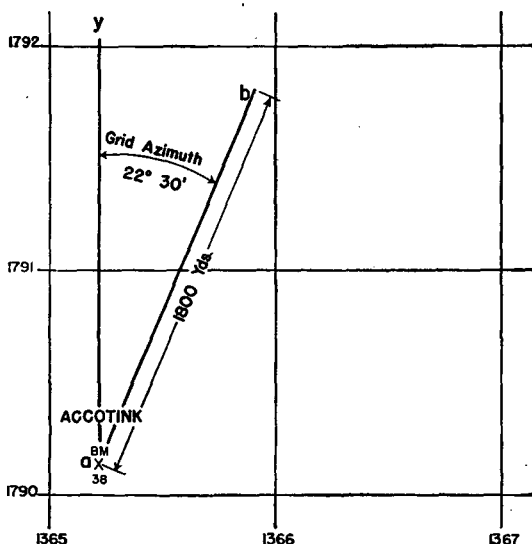

FIGURE 24.—Polar coordinates: BM 38, Accotink (village), distance 1,800 yards, on grid azimuth $22^{\circ}30'$.

- (3) Geographic coordinates.
- (4) Grid coordinates.

b. Rectangular and polar coordinates are classified as relative coordinates because they are determined by reference to base points (and directions) local to some map and selected by some individual. Thus an indefinite number of polar or rectangular coordinates may be assigned to a single point.

Geographic and grid coordinates are termed absolute coordinates because each is determined by reference to a permanently fixed base point and direction which have been officially adopted for that purpose. Thus only one set of geographic coordinates or, for any grid zone, only one set of grid coordinates can be assigned any point and this set of coordinates is not affected by the selection of map.

■ 30. POLAR COORDINATES.—Polar coordinates are used in designating points located with a compass in the field and in designating positions on maps not equipped with the military grid. They consist of an angle from a known base direction and a distance from a known base position. The base position is the origin of coordinates. It may be a fixed landmark, a survey monument, or any other position easily identified on the map and on the ground. The base direction may be true, magnetic, or grid north or south. The angle may be expressed as azimuth or bearing, the distance in any convenient distance unit. The base position or origin should be fully described.

Examples: Walla Walla quadrangle, BM 1224, on main road 2 miles westerly from Waitsburg, S. $22^{\circ}45'$ W. magnetic (1920) 4.62 miles.

Battle map, Fort Belvoir, 1:20,000 (1935), BM 38, Accotink (village), distance 500 yards N. 30° W. magnetic.

Battle map, Fort Belvoir, 1:20,000 (1935), BM 38, Accotink (village), distance 1,800 yards, on grid azimuth $22^{\circ}30'$. The point so designated is marked *b* in figure 24. The base position, BM 38, is marked *a*, the distance from the base position is the line *ab*, the base direction (grid north) is *ay*, and the angle from the base direction is *yab*.

In dealing locally with many points common to a single map sheet, the sheet reference may be omitted.

a. To plot position of point, polar coordinates of which are given.—(1) Locate on the map the landmark or other base position (origin) given.

(2) Through the base position draw a guide line parallel to the base direction.

(3) With a protractor, point off from the guide line radially about the base position the given angle (azimuth or bearing).

(4) Through the point thus established and the base position (origin) draw a guide line.

(5) Along this guide line from the base position lay off the given distance to scale.

b. To determine polar coordinates of map position with respect to given position and given direction.—(1) Locate on the map the given base position and through it draw a guide line parallel to the base direction.

(2) Draw another guide line through the base position and the point whose polar coordinates are sought.

(3) With the protractor, measure the angle (azimuth or bearing) which the direction line established in (2) above makes with the base direction line established in (1) above.

(4) With a suitable scale at the R.F. of the map, measure the distance from the base position to the point the coordinates of which are sought.

■ 31. RECTANGULAR COORDINATES.—Rectangular coordinates are used in designating points on ungridded maps without the aid of a protractor. They consist of two distances measured at right angles from a base position. The base position (origin) should be a landmark, survey monument, or other well-established position. The base position, distances, and directions should be fully stated, thus:

Walla Walla quadrangle, NE. cor. T. G. N., R. 36 E., thence due east 811.7 yards, thence due north 409.2 yards.

Battle map, Fort Belvoir, 1:20,000 (1935), BM 38, Accotink (village), 1,500 yards east (magnetic), 1,100 yards north (magnetic). The point so designated is marked *c* in figure 25. The base position, BM 38, is marked *a*, the base direction (magnetic north) is *am*, the direction of the line *ab* (grid east) makes a right angle with the line *am*, and the respective distances are *ab* and *ac*.

a. To plot map position, rectangular coordinates of which are given.—(1) Locate on the map the base position (origin) given.

(2) Through the base position draw a guide line parallel to the base direction.

(3) Through the base position draw a guide line at right angles to the base direction.

(4) From the base position along these lines point off to scale the respective distances in the respective directions as given.

(5) Treat these distances as the adjacent sides of a rectangle; complete the rectangle (other two sides) with construction lines. The intersection of these two construction lines is the point sought.

b. To determine rectangular coordinates of map position with respect to given base position and direction.—(1) Identify on the map the given point and the given base position.

(2) Through the base position draw a guide line parallel to the base direction.

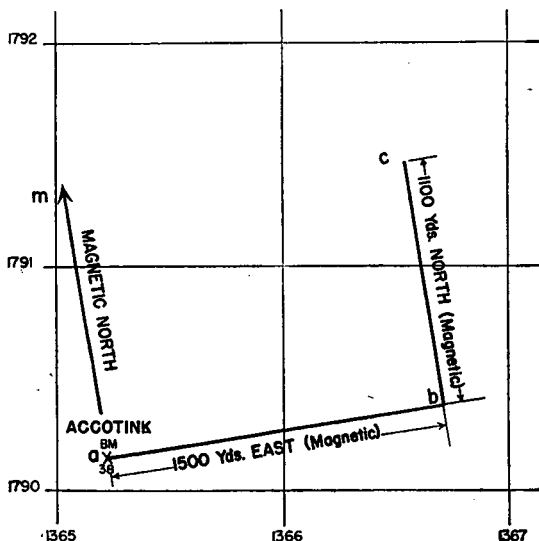

FIGURE 25.—Rectangular coordinates: BM 38, Accotink (village), distance 1,500 yards east magnetic, 1,100 yards north magnetic.

(3) Through the base position draw a guide line at right angles to the base direction.

(4) Through the given point drop perpendiculars to the lines established in (2) and (3) above.

(5) From the base position scale the distance along the guide lines of (2) and (3) above to the respective perpendiculars. These distances are the rectangular coordinates sought.

■ 32. GEOGRAPHIC COORDINATES.—The system of latitude and longitude lines projected on a map represents the geographic or spherical grid covering the earth. In this system the base position (or origin) is the intersection of the meridian of Greenwich, known as the prime meridian, with the Equator. The base direction is true north (or south). Distance on the spheroid (earth) is reckoned in units of degrees, minutes, and seconds of latitude up to 90° north or south of the Equator, and in degrees, minutes, and seconds of longitude up to 180° , east or west of the prime meridian. The location of any point on the surface of the earth is defined in terms

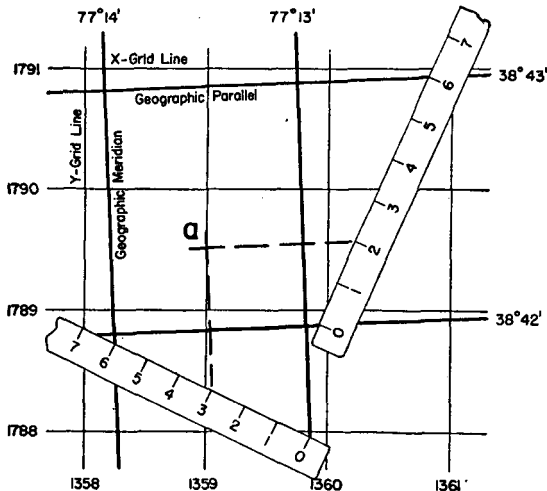

FIGURE 26.—Geographic coordinates: latitude $38^\circ42'20''$ N., longitude $77^\circ13'30''$ W.

of the parallel of latitude and the meridian of longitude which intersect at the point, thus, latitude $38^\circ32'20''$ N., longitude $77^\circ34'30''$ W. The latitude and longitude of a point constitute its geographical or spherical coordinates. However, meridians of longitude converge at the poles. Therefore, units of longitude decrease in units of linear distance from a maximum at the Equator to zero at the poles. Since the sphere cannot be developed as a plane, other variations are introduced in maps by the characteristics of pro-

jections used in map construction. While units of latitude and longitude can be converted to distances in meters, yards, miles, etc., by computation or use of tables, the spherical units would not occur, except by fortunate coincidence, in rational multiples of the linear unit. Lines of the spherical grid are necessarily curves or projections of curved lines and vary with latitude and projection. Such variations from straight lines and true distances within the scope of a sheet of the terrain or the tactical map are negligible. For practical map-reading purposes they may be disregarded and the spherical grid may be treated graphically in all respects as a rectangular grid. The 5-minute lines of the geographic grid appear in full or by border registration on topographic sheets. The 1-minute lines of the geographic grid appear registered on some large-scale maps by border ticks and grid intersections. Geographic coordinates are used in designating positions in large indefinite areas, in unmapped areas, and on geographic (ungridded) maps.

a. To plot positions of point, geographical coordinates of which are given.—(1) Identify on the map the two lines of the geographic grid, both of latitude and longitude, which fall nearest to and on each side of the position to be plotted. This may be readily done by inspection of the map in comparison with the given coordinates. In case the lines of the grid do not appear in full on the map, draw in the lines by joining the border ticks and grid intersections. In either case the point sought falls somewhere within the quadrangle whose sides are lines (arcs) of known latitude and longitude. For a battle map (1: 20,000), this is a 1-minute quadrangle (60 seconds by 60 seconds). For a topographic sheet, this is a 5-minute quadrangle (300 seconds by 300 seconds).

(2) The problem then reduces itself to the mechanical operation of dividing the quadrangle into seconds of longitude and seconds of latitude, pointing off the seconds place required by each coordinate. One of these points will fall on the meridian of longitude which passes through the point sought. The other will fall on the parallel of latitude which passes through the point sought. The significant parallel of latitude and meridian of longitude are now struck in as guide lines. Their intersection is the point sought.

(3) Points on the significant parallel of latitude and meridian of longitude are readily located with the engineer's scale

used as a diagonal scale of proportional parts between the available grid lines. For the 1-minute grid the scale should be placed across the lines at any angle so that 60 convenient divisions span the distance. For the 5-minute grid 300 divisions of the scale should span the distance between lines. In each case each division of the scale indicates a second of latitude or longitude, depending upon which coordinate is being plotted.

(4) Figure 26 illustrates the location of a point *a*, the geographic coordinates of which are latitude $38^{\circ}42'20''$ N., longitude $77^{\circ}13'30''$ W.

b. To determine geographic coordinates of map positions.—

(1) By inspection of the map, identify the grid quadrangle in which the point lies, drawing in the sides of the quadrangle when the grid appears registered only. The value in degrees and minutes of the meridians of longitude and parallels of latitude which form this quadrangle appears in print on the borders of the map. The problem, then, is to determine the position of the point within the quadrangle in seconds of latitude and seconds of longitude.

(2) Use the engineer's scale as a scale of proportional parts as described in *a*(3) above to establish the seconds lines within the significant quadrangle, except in each case (the two positions of the scale, one for latitude and one for longitude, respectively) the scale should pass through the point whose coordinates are desired. The number of seconds sought may now be read directly from the edge of the scale at the point in the direction of increasing grid values within the grid quadrangle. This added to the recorded value in degrees and minutes of the side of the significant quadrangle lowest in value yields the coordinate sought in degrees, minutes, and seconds.

■ 33. GRID COORDINATES.—*a. General.*—(1) In order to provide a standardized system of rectangular coordinates which are easy to read, the military grid is printed upon the map. The grid is composed of a set of parallel grid north and south lines showing distances in thousands of yards grid east of the origin, and a set of grid east and west lines showing distances in thousands of yards grid north of the origin of coordinates for the grid zone. The distance of any point grid east of the origin is called the *X*-coordinate. The distance

of any point north of the origin is called the *Y*-coordinate. In writing coordinates the *X*-coordinate is written first and the *Y*-coordinate last, with a dash between, and the whole inclosed within parentheses. Thus in figure 27 point *A* is located at (198-262). The coordinates are read in the same manner as they are written. In locating a point the key phrase "READ—RIGHT—UP" should be remembered.

(2) Coordinates are written and read to 1,000 yards and decimal parts thereof. In figure 27 the coordinates of point *B* are (197.8-263.7).

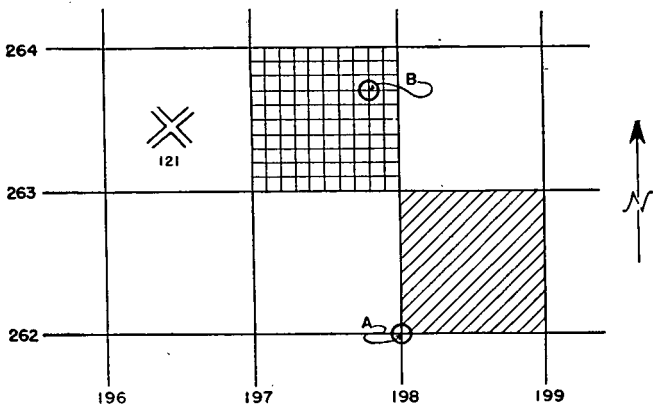

FIGURE 27.—Coordinates.

(3) It is customary to drop all but the last two digits; hence the coordinates of point *B* may be written or read (97.8-63.7).

(4) When a point is easily identified and only one of such exists within the grid square, it is necessary merely to refer to the southwest corner of the grid square in which it is located. For example, in figure 27 crossroads 121 could be designated as "CR 121 (96-63)."

b. Coordinate scale.—The use of the coordinate scale in reading or plotting the coordinates of a print on a map is explained in detail in FM 21-25.

c. Coordinates with engineer's scale.—The engineer's scale or any other suitably graduated scale may be used conveniently as a scale of proportional parts to plot a point within

the significant grid square. Let it be required, for instance, to plot a point N , the coordinates of which are (25.35-76.60) (fig. 28). Select any 10 equal subdivisions on the scale such that their total length is equal to or slightly greater than the grid interval on the map. Lay the scale in position ① shown in figure 28 so that the zero is on the 25,000 grid line and the 10 is on the 26,000 grid line. Mark on the map the point a at 3.5 on the ruler. Slide the scale down to position ② and again mark on the map the point a' at 3.5 on the scale. Draw the line aa' . Now place the scale on the map in position ③ so that the zero is on the 76,000 line and

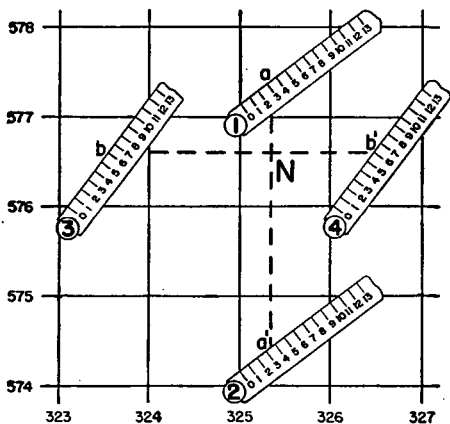

FIGURE 28.—To plot position of point (25.35-76.60) with engineer's scale on terrain map (1: 20,000) having 1,000-yard grid. (Not reproduced to scale.)

the 10 is on the 77,000 line. Mark on the map the point b at 6.0 on the scale. Slide the ruler to the right to position ④ and again mark on the map the position b' at 6.0 on the scale. Draw the line bb' . The intersection of the lines aa' and bb' is the plotted point N required. If desired, the subdivisions may be further subdivided into 10 equal parts, as on the engineer's scale, to give the position of the point by grid lines of 10-yard intervals. It can be seen that reading coordinates with the engineer's scale is accomplished in the same manner. (See fig. 29.)

■ 34. MILITARY GRID SYSTEM.—*a.* The standardized system of rectangular coordinates discussed in paragraph 33 is the grid system devised for use on military maps in order to avoid the difficulties and inconveniences inherent to the spherical grid. A rectangular grid superimposed on a polyconic projection of the whole continental United States would prove no more useful than a map on that projection and for the same reasons. Distances on the rectangular grid would vary prohibitively from true ground distances in the distorted areas near the edges of the map. However, by limiting the width of the projection to about 9° of longitude, the maximum distortion along the edge of the projection never exceeds 2.57 yards per 1,000 yards, or about $\frac{1}{4}$ of 1 percent, an error of

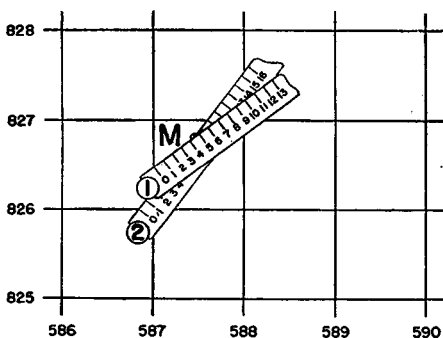

FIGURE 29.—To read grid coordinates of point (87.45—26.80), on terrain map (1: 20,000 scale) having 1,000-yard grid, with engineer's scale.

no military consequence, since the changes in dimensions of an ordinary map sheet due to weather conditions may exceed that amount.

b. For the purposes of superimposing the rectangular grid, the northern half of the continental Western Hemisphere has been divided into seven zones, each 9° of longitude wide. Each zone is a separate polyconic projection. When the military grid system was first established it extended from 28° N. latitude to 49° N. latitude. This system, known as the continental system, was sufficient for continental United States only. Later, in order to take care of Panama and the Caribbean area, the equatorial system, extending from

7° N. to 28° N., was set up. These two systems have different Y origins, and hence any point in this area will have the same X-coordinate in both systems but different Y-coordinates. All grids are identical in structure but each has a separate origin 8° of longitude distant from its neighbor.

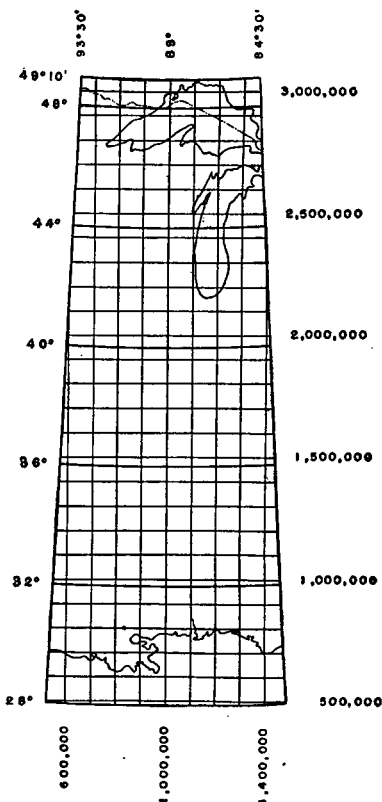

FIGURE 30.—Special military map of continental system grid zone C.

The grids therefore overlap 1° of longitude along the borders, with a net width of 8° of longitude between the central meridians of the overlaps. These zones are designated by a letter in accordance with the following table, that portion

TABLE III.—Grid zone systems in northern half of continental Western Hemisphere

Zone	Limiting meridian of zones	Origin of coordinates X	Grid values assigned to origin X yards	Equatorial system		Continental system	
				Origin of coordinates Y	Grid values assigned to origin Y yards	Origin of coordinates Y	Grid values assigned to origin Y yards
A	68°30' W., 77°30' W	73° W	1, 000, 000	Equator	Zero	40°30' N	2, 000, 000
B	76°30' W., 85°30' W	81° W	1, 000, 000	do.	do.	40°30' N	2, 000, 000
C	84°30' W., 93°30' W	89° W	1, 000, 000	do.	do.	40°30' N	2, 000, 000
D	92°30' W., 101°30' W	97° W	1, 000, 000	do.	do.	40°30' N	2, 000, 000
E	100°30' W., 109°30' W	105° W	1, 000, 000	do.	do.	40°30' N	2, 000, 000
F	108°30' W., 117°30' W	113° W	1, 000, 000	do.	do.	40°30' N	2, 000, 000
G	116°30' W., 125°30' W	121° W	1, 000, 000	do.	do.	40°30' N	2, 000, 000

of the State of Maine falling to the east of longitude $68^{\circ}30'$ being included in zone A.

c. The limits of the grid zones are shown in table III and illustrated in figure 31. The zone letter appears on all maps containing grids. In designating points by grid coordinates,

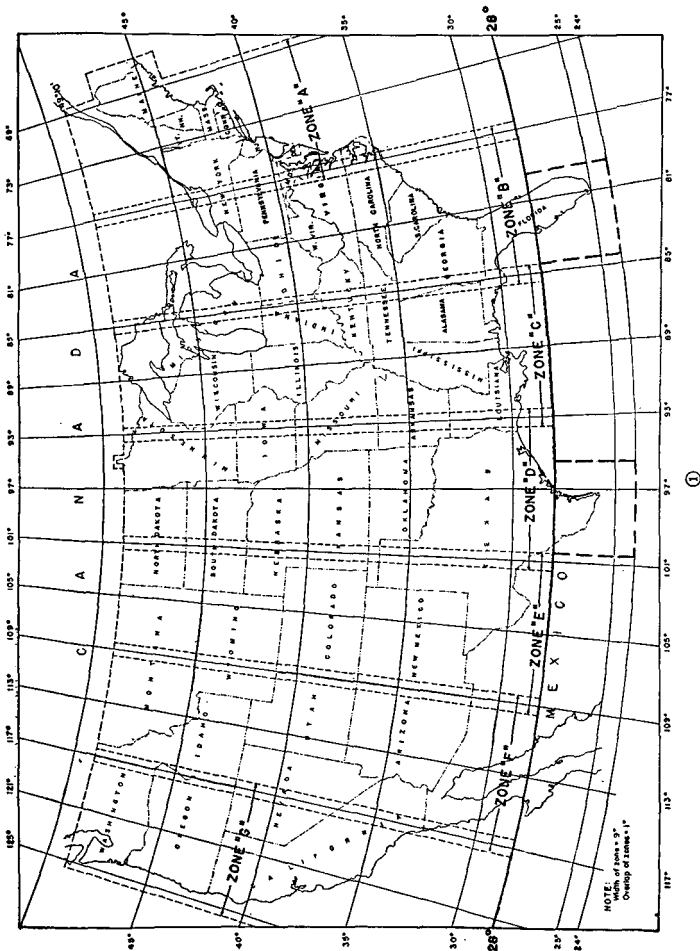
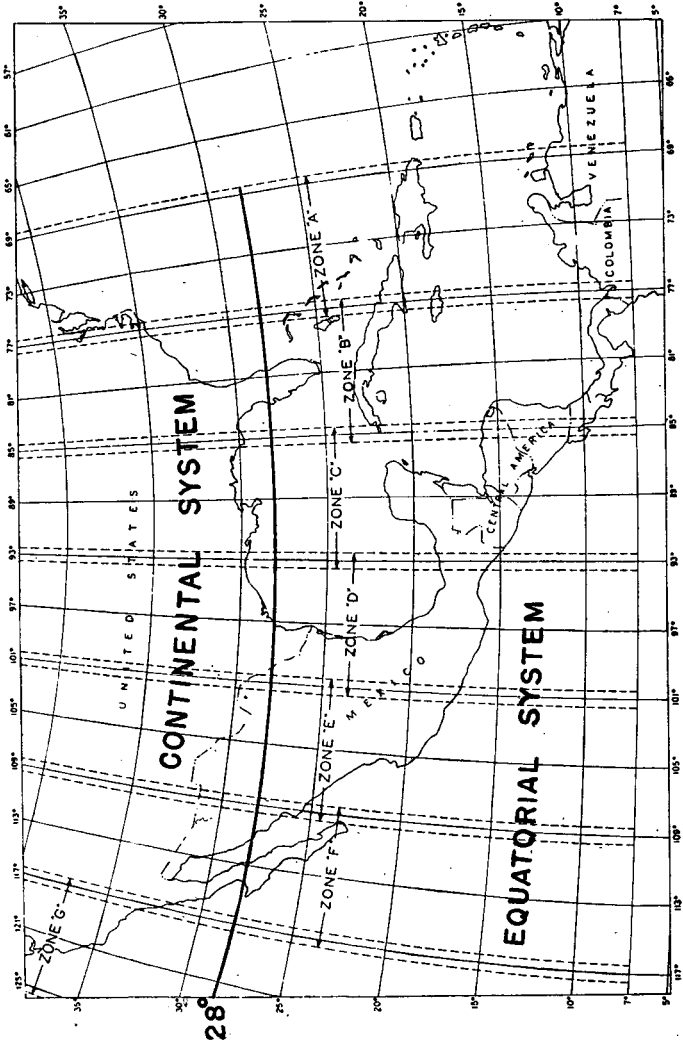

FIGURE 31.—Designation of military grid systems.



⑤

Figure 31.—Designation of military grid systems—Continued.

the name of the map sheet and not the zone letter should be used as primary reference.

■ 35. CONTINENTAL SYSTEM.—*a.* In each zone the intersection of its central meridian with the parallel of latitude $40^{\circ}30'$ is selected as the origin of coordinates designated by *O*. The central meridian is chosen as the *Y*-axis and a right line tangent to latitude $40^{\circ}30'$ at *O* is chosen as the *X*-axis. In terms of yards, the grid coordinates of all 5-minute intersections of latitude and longitude within the whole grid zone are computed with respect to these axes and the origin *O*. The coordinates of intersections in all other quadrants, except the first, involve some negative quantities which are undesirable for simplicity. In order to make positive all coordinates which appear on military maps embraced within the zone, the computed values are transferred to a new origin *O'* exactly 1,000,000 yards grid west and 2,000,000 yards grid south of the origin *O*. This is effected by simply adding 1,000,000 yards to all computed *X*-coordinates and 2,000,000 yards to all computed *Y*-coordinates. It is the point *O'* and axes *O'-X* and *O'-Y* to which all grids and grid values appearing on all military maps are related. The original origin *O* has no further significance. This scheme is shown in figure 30 and table III, and the rectangular grid system illustrated therein is referred to as the military grid system.

b. Since the grids for all zones are identical in structure, only one set of original computations suffices for all zones simply by changing in the tables the longitude values successively through 8° , 16° , 24° , etc., of longitude, respectively. (See Special Publication 59, U. S. Coast and Geodetic Survey.)

c. The military grid appears registered on gridded maps in two series of parallel lines at right angles to each other. On sheets of the terrain map (1: 20,000), these lines form 1,000-yard squares. On sheets of the tactical map (1: 62,500), these lines form 5,000-yard squares. The central meridian of the overlap between adjacent grid zones is the dividing line between the zones. Any map which falls within the 1° overlap between grid zones always shows in solid black lines the grid of the zone to which the map pertains. The grid of the adjacent overlapping zone may also appear registered by means of grid intersections (small crosses) on the face of the sheet and ticks around the border lines. The scheme is useful in effecting

transition of data from one zone to another. The lines of the overlapping zone when needed may be struck in by simply joining the registration points. Since the grid lines of each zone are all parallel to the central meridian of the zone and since meridians converge to the poles, the lines of overlapping grids will always cross at distinct angles.

d. The distance of each north and south grid line, grid east of the zero point or origin of coordinates, is marked in thousands of yards along the south border of a gridded map. The distance of each east and west grid line, grid north of the zero point or origin, is marked in thousands of yards along the west border of a gridded map. The numbers which identify the north and south grid line and the east and west grid line which intersect at or nearest to the southwest corner of a gridded map are written out in full in yards. In marking all other grid lines, the digits common to the sheet may be omitted. When the grid of an overlapping zone appears registered by ticks and grid intersection on a map, the ticks of the north and south and east and west grid lines, respectively, which intersect at or nearest to the southeast corner, are marked in full to yards. No other grid lines of the overlapping zone are marked.

e. By agreement with the War Department, sheets of the topographical atlas of the United States Geological Survey adopted as tactical maps will have the 5,000-yard grid registered by ticks along the borders.

NOTE.—The above methods of showing grids on a map are followed by the Corps of Engineers in the reproduction of all gridded maps. There are maps in common use for school purposes, such as the Gettysburg map, on which only a local grid system is used. The reader should not confuse such a grid with the military grid system.

■ **36. EQUATORIAL SYSTEM.**—*a.* The equatorial system, using the same zones as the continental system, has the latitudinal origin at the Equator, and covers the area between the 7° N. and 28° N. parallels. The system is otherwise similar to the continental system. Tables and methods of computation for the equatorial system are found in Corps of Engineers publication "Grid System for Military Maps for 7° to 28° North Latitude."

b. In the overlapped areas below 28° N. in Texas and Florida, care must be taken not to confuse the two grid systems. In the absence of other data, it may be assumed

that the continental system is used within the limits shown on figure 31②.

■ 37. DETERMINATION OF UNKNOWN DIRECTIONS, DISTANCES, OR COORDINATES.—*a. To determine distance between two points, grid coordinates of which are given.—(1) Graphically.—Plot*

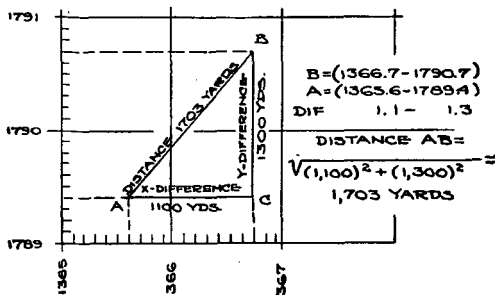

FIGURE 32.—Distance between two points on map by solution of right triangle.

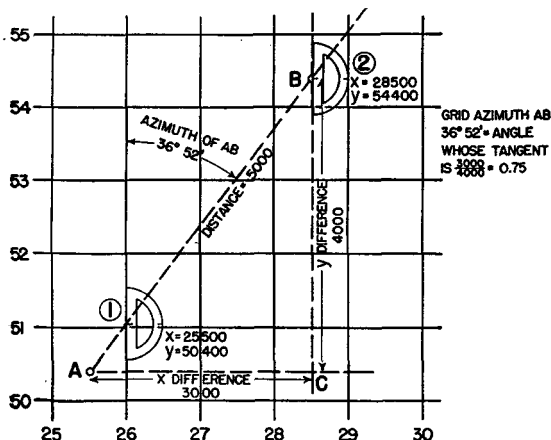

FIGURE 33.—Determination of grid azimuth of line on gridded map.

the positions of the two points on the map. If no map is available, plot the relative position of the points to scale on an improvised grid. In either case, scale directly the distance between the plotted points.

(2) *By solving right triangle* (fig. 32).—The distance between the two points is the hypotenuse of a right triangle whose legs are the differences, respectively, between the *X*- and *Y*-coordinates of the two points. The distance in yards is therefore the square root of the sum of the squares of *X* difference and *Y* difference. The method is completely illustrated in figure 32.

b. To determine grid azimuth of line between two points, grid coordinates of which are known (fig. 33).—(1) *From map*.—Plot the position of the two points *A* and *B* on the map or plot the relative position of the points on an improvised grid to scale as shown in figure 33. Join the plotted positions by a straight line and prolong if necessary to intersect a north-south grid line. With a protractor, as shown in figure 33①, measure the angle from the north-south grid line clockwise to the straight line indicating the significant direction, bearing in mind that a line has two directions differing in azimuth by 180°.

(2) *By plotting right triangle*.—Plot to scale on plain or cross-section paper or the gridded map the right triangle whose legs are the *X*-difference and the *Y*-difference of the given coordinates of the respective points which may be represented by *A* and *B* in figure 33. In the triangle *ABC* so formed, *CB* is the base or grid north direction. With the protractor at *B* (fig. 33②), measure clockwise the angle from *CB* prolonged either to *AB* prolonged or to *BA*, depending upon which azimuth (differing by 180°) is required.

(3) *By trigonometric functions* (fig. 33).—(a) The grid azimuth sought is, by inspection of the figure, seen to be equal to the angle *ABC*, whose tangent is

$$AC/BC = \frac{X\text{-difference}}{Y\text{-difference}} = 3,000/4,000 = 0.75$$

(b) From a table of natural tangents this corresponds to the angle 36° 52', which is the grid azimuth of the line in the first quadrant.

(c) In the SE quadrant subtract this angle from 180°, in the SW quadrant add to 180°, and in the NW quadrant subtract from 360°.

(d) The method is useful when the points fall on separate sheets or the map is distorted.

c. Determination of coordinates of point when distance and directions are given from point with known grid coordinates.—

When the distance between two points is comparatively great or lie on sheets of a different scale, the coordinates of one are established mathematically from the one with known coordinates as follows:

(1) Convert direction into bearings using grid north (see par. 21).

(2) Look up sine and cosine of the angle and multiply by the distance.

(3) The sine multiplied by the distance will give the east or west distance to be added algebraically to the first coordinate given; an east bearing is plus; a west bearing is minus.

(4) The cosine multiplied by the distance will give north or south distance to be added algebraically to the last coordinate given; a north bearing is plus; a south bearing is minus.

(5) *Example* (fig. 34).

Given: Coordinates of point *a* (898-252).
 Direction of line from *a* to *b*=magnetic azimuth $317^{\circ} 28'$.
 Grid declination $9^{\circ} 31'$.
 Distance 9,720 yards.

Required: Coordinates of point *b*.

Solution: Grid azimuth= $317^{\circ} 28'$ plus $9^{\circ} 31'$ = $326^{\circ} 59'$.
 Bearing= 360° minus $326^{\circ} 59'$ =N. $33^{\circ} 01'$ W.
 From tables of natural trigonometric functions—

Sine $33^{\circ} 01'$ =0.54488.

Cosine $33^{\circ} 01'$ =0.83851.

0.54488 times 9,720=5,296 yards.

0.83851 times 9,720=8,150 yards.

Coordinates (898-252 mean 898,000 yards east of basic origin and 252,000 yards north of basic origin.

Since the bearing of the line is N. $33^{\circ} 01'$ W. (IV or NW quadrant).

$898,000 - 5,296 = 892,704$ yards.

$252,000 + 8,150 = 260,150$ yards.

Hence coordinates of point *b* are (892.7-260.2).

d. To superimpose grid on map from point with known grid coordinates (fig. 35).—Establish, by some means previously

mentioned, the grid north on the map. Draw lines *N—S* and *E—W* through the known point. Along these lines scale off the desired grid spaces. Extreme care should be exercised in establishing a grid from one point to insure accuracy.

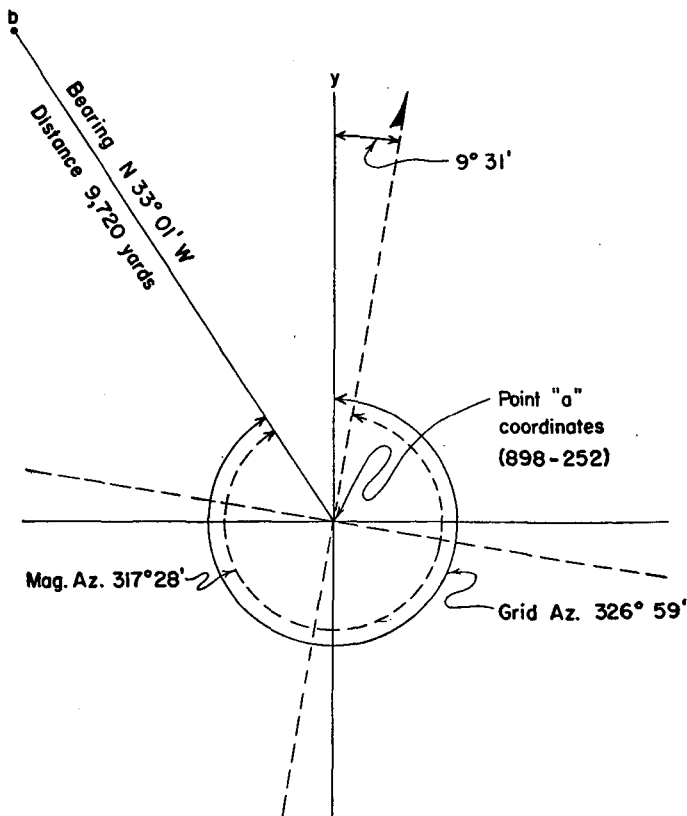

FIGURE 34.—Grid coordinates from known point.

When some other point of known coordinates exists on the map a check should be made with it.

■ 38. CONSTRUCTION OF MILITARY GRID FROM GEOGRAPHIC COORDINATES.—For transformation of geographic coordinates

to grid coordinates, or vice versa, see United States Coast and Geodetic Survey Special Publication No. 59 and "Grid System for Military Maps for 7° to 28° North Latitude"; paragraph 61, TM 5-230; and paragraph 117*f*, TM 5-235.

SECTION V

ELEVATION AND RELIEF

■ 39. **ELEVATION.**—Elevation is the measure of vertical distance from a known datum plane. For most maps the datum

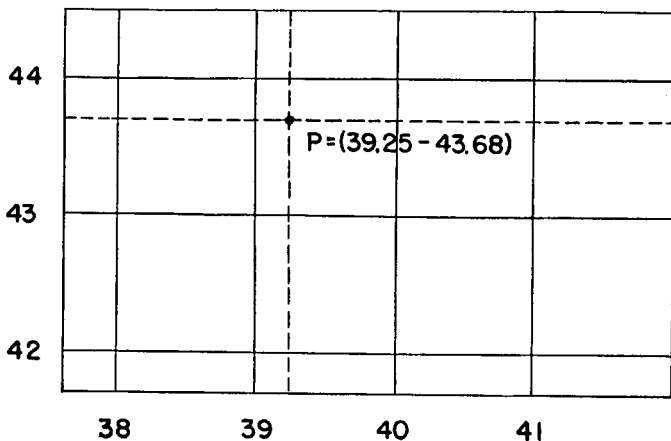

FIGURE 35.—To superimpose a grid on a map from a point with known coordinates.

is mean sea level and zero elevation. Elevation is expressed in feet above or below mean sea level. When above mean sea level, elevation is plus; when below mean sea level, elevation is minus. Where no indication is given the elevations are always taken as plus.

■ 40. **RELIEF.**—*a.* The variation in the height of the earth's surface, as ridges, valleys, etc., is termed "relief." As the exact nature of the terrain has a marked influence on military operations, it is important that the military commander of every unit familiarize himself with the "lay of the land" in which he is operating. This familiarity cannot always be

obtained by actual reconnaissance beforehand but often must be gained solely by study of topographic maps. The map, then, must convey to the map reader a definite impression of the ground forms. The ability to comprehend relief from the map requires an understanding of the way in which the various ground forms have been produced by nature.

b. There is a considerable degree of regularity and system in ground forms, due to erosion. Not all the water from heavy rains can seep into the soil; much of it runs off. At one point a little stream begins; as it flows downward another joins it; soon several unite into a fair-sized creek, which rushes along, carrying its burden of soil into the main valley, whence the river may carry it into the sea. This simple process, continued for ages, has sufficed to carve the surface of the earth into the form we find today.

c. Since most of our present ground forms are the result of erosion, it is evident that the drainage scheme of an area is the key to its topography. On maps where streams are indicated and on aerial photographs, this key is in evidence; converging streams show a general slope to a valley; diverging fingers of streams portray a crest or ridge. The drainage net and ridge lines constitute the "master lines" of the terrain. Points of change in horizontal or vertical direction of these lines are known as "critical points." Getting the "lay of the land" consists of grasping the significance of these master lines. The method adopted for showing relief on a map must be one which will convey to the map reader an immediate conception of the drainage and ridge lines of the system of relief.

■ 41. METHODS OF REPRESENTING RELIEF.—Since the map is flat, special conventional signs are necessary to show relief. The most common methods used on maps are as follows:

a. *Hachures* (fig. 36).—A method frequently used to indicate relief in a general way is by the use of hachures. It is particularly useful when the available data are inadequate for the more accurate representation of relief by contours, or when the purpose of the map does not justify the more complicated and time consuming methods. This method of representing relief has been adopted for the Strategic Map of the United States (scale 1:500,000) and will be frequently found on large as well as small scale foreign maps. Hachures

are short parallel or slightly divergent lines drawn in the direction of slopes, closely spaced on steep slopes, wide apart on gentle slopes, and convergent toward the tops of ridges and hills. The resulting shadow effect gives an excellent pictorial representation of hilltops, ridges, and valleys, and enables the map reader to gain a fair conception of the relative slopes of various parts of the terrain.

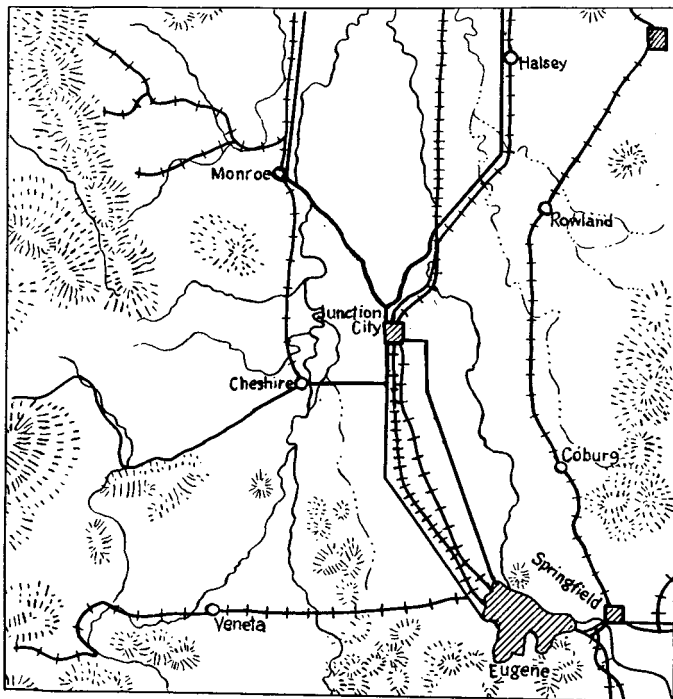

FIGURE 36.—Relief by hachures.

b. Color-layer system.—Color-layer systems of relief representation consist of using different colors or different tones of the same color to distinguish different zones of elevation. These resulting color bands are bounded by contours which are usually shown on the map. Contours falling within color zones are usually omitted. A key to the color system showing

the succession of colors and the elevation zones to which they pertain is given on the map margin. The colors of the elevation gradient should be selected to produce a harmonious effect but there should be sufficient contrast between the colors to insure ease of reading. This method is used on aerial navigation charts published by the Army. The color gradient used on these maps is shown in FM 21-30.

c. Contours.—A contour line represents an imaginary line on the ground, every part of which is at the same elevation usually applied to mean sea level. Such a line could be drawn at any altitude but in mapping only the contours at regular intervals of altitude are shown. The line of the seacoast itself is on the zero contour line if mean sea level is assumed to be the zero datum plane. If the sea should rise 20 feet above mean sea level, the new seacoast line would then be on the 20-foot contour line. Contour lines show the shapes of the hills, mountains, and valleys, as well as their altitudes. Successive contour lines that are far apart on the map indicate a gentle slope; lines that are close together indicate a steep slope; and lines that run together indicate a cliff. Contour lines never cross except in the case of an overhanging cliff. The sketch in figure 37① represents a river valley that lies between two hills. In the foreground is the sea, with a bay that is partly inclosed by a hooked sand bar. On each side of the valley is a terrace into which small streams have cut narrow gullies. The hill on the right has a rounded summit and gently sloping spurs separated by ravines. The spurs are truncated at their lower ends by a sea cliff. The hill at the left terminates abruptly at the valley in a steep scarp from which it slopes gradually away and forms an inclined tableland that is traversed by a few shallow gullies. The manner in which contour lines express altitude, form, and grade is shown in figure 37②. Each feature shown in figure 37① is represented on the contour map (fig. 37②) directly beneath its position in figure 37①.

d. Depth curves.—A contour showing points of equal elevation below the level of any body of water is called a depth curve. These curves will indicate depths below a certain datum, usually mean low water level for the body of water concerned. The vertical interval is frequently expressed in fathoms (6 feet).

■ 42. CHARACTERISTICS OF CONTOURS.—In order to appreciate the representation of relief and elevation differences by contours, study must be given to the basic characteristics of them. FM 21-25 describes very thoroughly these characteristics. Briefly, it may be observed that contours on a map—

- a. Are wavy in appearance.
- b. Are usually V-shaped in narrow valleys and U-shaped on noses of hills.

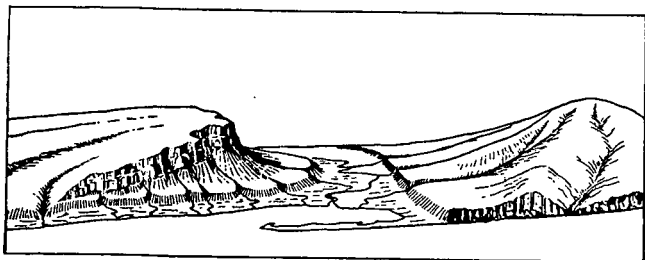

①



②

FIGURE 37.—Relief by contours.

- c. Always close, on or off the map.
- d. Are at right angles to the lines of steepest slope.
- e. Are spaced directly as the variation of the slope; close on steep slopes, far apart on gentle slopes.
- f. Are roughly parallel to the adjacent contour lines. Figure 38 shows the relation of profile to contours.

■ 43. CONTOUR INTERVAL.—*a.* The contour interval, or the vertical distance in feet between one contour and the next, is stated as marginal information, usually under the scale, at the bottom of each map. This interval differs according to the topography of the area mapped and the scale of the

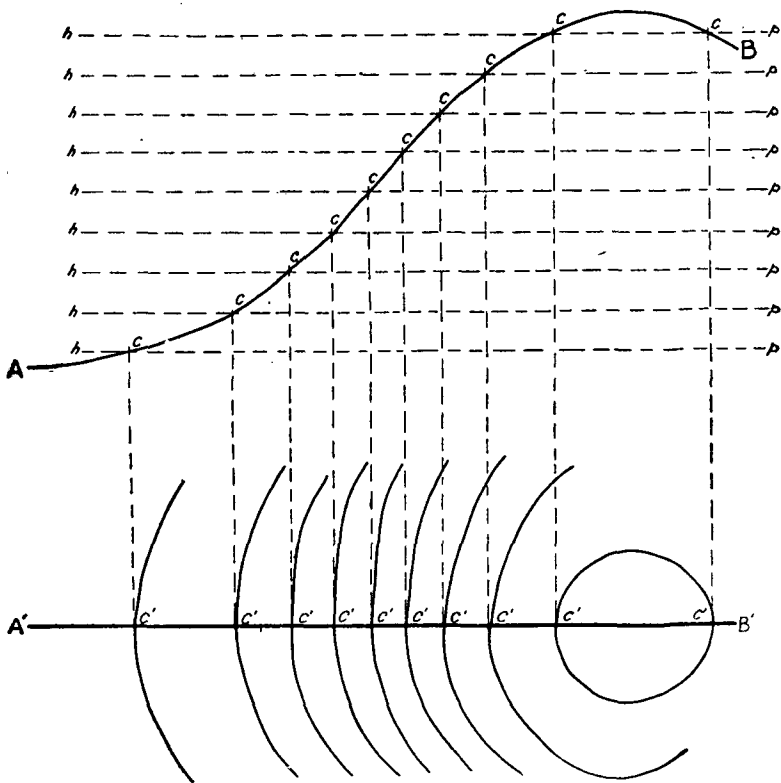

FIGURE 38.—Relation of profile to contours.

map; in a flat country it may be as small as 1 foot; in a mountainous region it may be as great as 250 feet.

b. For military use it is necessary that the various sheets of a map of any given area have a common scale and contour interval or intervals that match. In order that peacetime

practice throughout the United States be consistent, the War Department (AR 300-15) and the United States Geological Survey have adopted the following contour intervals for standard quadrangle maps. The intervals in general conform to contour intervals found on most existing topographic maps.

(1) Contour intervals of 5, 25, 50, or 100 feet in the States which lie all or mostly west of longitude 103° as follows: Washington, Oregon, California, Idaho, Nevada, Utah, Arizona, Montana, Wyoming, Colorado and New Mexico.

(2) Contour intervals of 5, 10, 20, 40, or 100 feet in the States which lie all or mostly east of longitude 103° . The 5-foot contour interval is used only on large-scale maps of limited areas.

c. On most maps every fifth contour line is made heavier than the others and is accompanied by figures showing the altitude at convenient intervals.

■ 44. ELEVATIONS OF IMPORTANT FEATURES.—The elevations of important features such as road junctions, summits, and surfaces of lakes, called spot heights, and those of bench marks are given on the map in figures to the nearest foot. More exact altitudes of bench marks are published in bulletins that are issued by the Geological Survey and the Coast and Geodetic Survey. On coastal charts the datum is mean low water.

■ 45. INTERPRETATION OF RELIEF BY CONTOURS AND MARKED POINTS OF ELEVATION.—a. Further understanding of the means of representing and interpreting relief and elevation on maps may be obtained from a study of the sketch represented in figure 39. This shows a section of a map contoured with a vertical interval of 20 feet.

b. The numbers along the edge of the sketch represent the respective elevations of the contours above mean sea level. By following the several contours across the sketch the elevations of various points may be determined. By study of the contour net as a whole the relief of the ground may be interpreted quickly by the practiced map reader. Thus the closed contours at points X, Y, and Z indicate hilltops. The numbers indicate that these hills are at elevations of 1,110, 1,130, and 1,105 feet, respectively. In speaking of unnamed hills on a topographical map, they are referred to by use of

their elevation; for example, hills Y and Z would be designated hill 1,130 and hill 1,105, respectively.

c. A further study of the sketch will indicate how the various terrain features are recognized. Point K represents a saddle between hills X and Y. It is also the watershed between the head of the stream system at P and the slope toward the bottom of the sketch from point A. The elevation of point K is approximately 1,030 feet (being between the 1,020- and 1,040-foot contours). Point N between hills Y and Z represents a saddle at an approximate elevation of 1,090

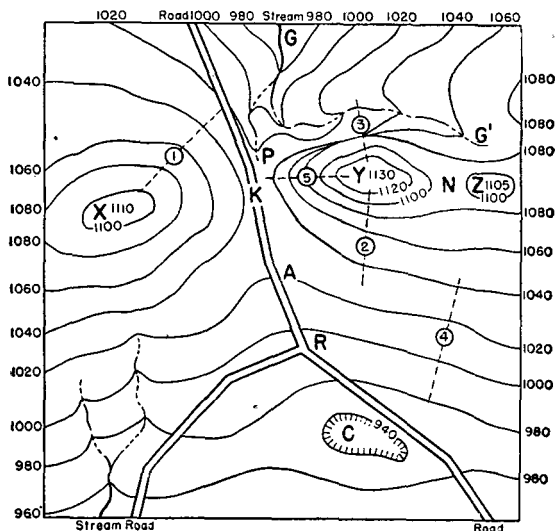

FIGURE 39.—Interpretation of relief.

feet. Along the dotted line ①, the uniform spacing of the contours and their distance apart indicate a uniform, gentle slope. Along the dotted line ②, the spacing of the contours is irregular, indicating varying slopes. Along the dotted line ③, the slope is steep, terminating in a cliff where the contour lines meet each other. Along the dotted line ④, the contours, being almost straight, nearly parallel and quite far apart, represent a very gently sloping plane surface. Along the nose indicated by the dotted line ⑤, the contours

are U-shaped with the bottom of each U pointing down hill. Where the contours cross the stream valley $G-G'$, they run up the valley on one side of the stream, turn in a sharp V and run back down on the other side; the bottom of the V formed at the stream crossing points up stream in contradistinction to the U's of the contours on the shoulder of the ridge at ⑤.

d. Since on maps, road junctions usually are given a number corresponding to their elevations above sea level, the road junction at R , about halfway between contours 980 and 1,000, would be designated RJ (road junction) 990. Crossroads are designated CR (followed by the elevation in the same way).

■ 46. APPROXIMATE CONTOURS AND FORM LINES.—*a. Approximate contours.*—When it has not been possible for the topographer to locate accurately contours for a map, they are shown to be approximate only by the use of broken lines.

b. Form lines.—Form lines are similar to contours in that they are drawn at right angles to the direction of steepest slope. However, form lines have no fixed interval and do not indicate elevations. Their purpose is to show the configuration of the ground.

■ 47. LOGICAL CONTOURING.—*a.* In mapping, contouring may be done by the topographer in the field by one of several methods:

(1) He may actually run out the location of the contours on the ground. This method is applicable to large-scale maps when great accuracy is desired and the expenditure of time and labor is economically justified.

(2) He may run out enough contours to define the ground forms and interpolate between them by eye.

(3) He may run out only stream and ridge lines, getting elevations on these lines at each change of slope or ground form. Such elevations defining the ground forms are known as "critical elevations." The contours may then be sketched in the field by eye between critical elevations. This method is the cheapest, quickest, and most commonly used.

b. Logical contouring may best be explained by an illustrative example. In figure 40① critical elevations have been measured by the topographer. The problem is to interpolate

10-foot contours so that the ground forms depicted will be logical.

(1) First, along the main stream, interpolate the elevations of all stream junctions not shown by assuming that the stream has a uniform slope between critical points. For example, there is a stream junction of unknown elevation

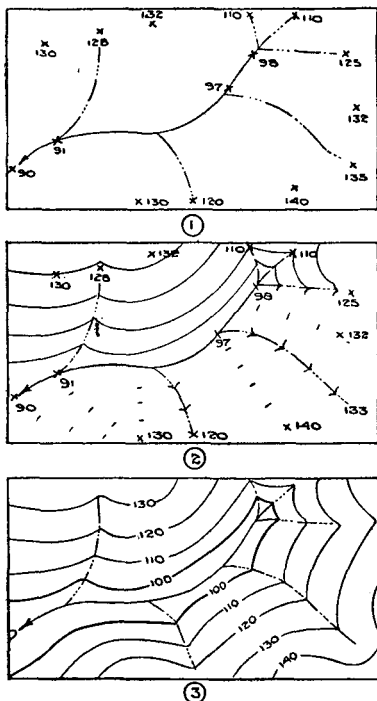

FIGURE 40.—Method of drawing contours by interpolation on drainage net where elevations are given.

between elevations of the stream of 91 and 97 feet, respectively. Between these two points the stream rises 6 feet. Because the stream junction, the elevation of which is sought, is approximately half the distance measured along the stream between elevations 91 and 97, it is assumed that the stream

has risen to that point only one-half of 6, or 3 feet. The elevation sought is therefore 94 feet.

(2) In this way, interpolate elevations which are multiples of 10 feet on all the streams. These are the points where contours cross the stream and are shown as V-shaped marks pointed upstream as in figure 40②.

(3) By interpolation between critical elevations determine where 10-foot contours round the ridges and indicate by lightly drawn U's. Since hills are normally rounded at top and slope off gradually at the bottom with the steepest rise on the slope of the hill (fig. 38), contours will have slightly closer spacing on the rise than at the crest or bottom.

(4) By building up one ground form at a time, connect the V's and U's with smooth contours as shown in figure 40③. Each spur between two streams in the illustration should be drawn in separately.

(5) Every fifth contour (starting from 0) should be made heavier than the rest and should have the elevation written on it.

c. The contours should be sketched while in the field. However, if enemy action or other cause makes this impossible, contours may be interpolated in the office, preferably with the aid of aerial photographs and a stereoscope, provided that critical points have been adequately determined.

■ 48. DETERMINATION OF ELEVATION.—*a.* In the discussion in paragraph 45, approximate elevations of specific points on the map were determined roughly by inspection. Where more accurate elevations are desired, some means of interpolation between contours becomes necessary. In the following procedure the refinement is for theoretical purposes only. Any interpolation from contours is an approximation upon which undue refinement may be misleading.

b. Refer to the margin of the map. To determine the elevation of any specific point, proceed as follows (fig. 41):

(1) If the point falls on a heavy contour, it is only necessary to follow that contour until the elevation appears and read it. For example, the elevation of the point *B* in the figure is read directly as 1,300 feet.

(2) If the point falls on a light contour, the elevation is found by reference to the adjacent heavy numbered contour

lines and interpolating. For example, the elevation of the point A is 1,260 feet.

(3) When the point lies between two contours as at C in figure 41—

(a) Find the elevation of the nearest contour line.

(b) Measure the shortest distance between the two adjacent contours along a line passing through the point C.

(c) Measure the distance along this line from the point in question to the nearest contour.

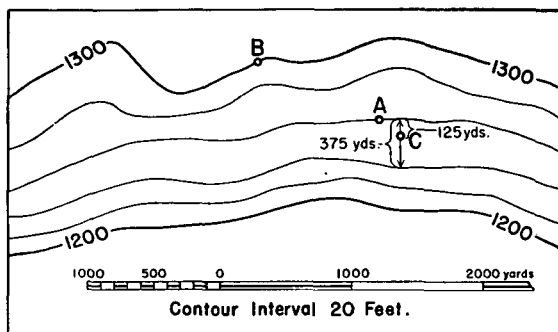

FIGURE 41.—Determination of elevation on contoured map.

(d) Solve the following equation:

$$\frac{\text{Distance from point to nearest contour}}{\text{Distance between contours}} \times \text{contour interval} \\ = \text{difference in elevation between point in question and} \\ \text{the nearest contour.}$$

Since the distance between adjacent contours at this place is 375 yards and since C is 125 yards from the nearest contour (the 1,260 contour), entering the equation given above,

$$\frac{125}{375} \times 20 \text{ feet} = 6\frac{2}{3} \text{ feet.}$$

Taking the nearest whole number of feet (7), the elevation at point C is 7 feet less than the elevation of the nearest contour, or $1,260 - 7 = 1,253$ feet. If the nearest contour is of lower elevation than the point in question, the difference in elevation must of course be added.

(4) When a point, the elevation of which is required, lies within a closed contour forming the top of a hill or the bottom of a depression, only an approximation of its actual elevation is possible.

SECTION VI

SLOPE, PROFILE, AND VISIBILITY

■ 49. **SLOPE.**—The inclination of the land surface relative to a horizontal plane is the slope, and slope is a function of two factors—horizontal distance and vertical distance. Two points are therefore necessary to determine these factors. The vertical distance is the difference in elevation of the points and on a contoured map may be interpolated from the contours. The horizontal distance is scaled from the face of the map. Along a straight line it is the scaled length of the straight line. Along a meandering stream, irregular road, or broken line, it is the scaled length of the meander line or other irregular distance under consideration. Both horizontal and vertical distance must be expressed by the same units, preferably feet. Slope may be computed or measured and expressed in terms of percent, mils, degrees, or as gradient. The slope of roads, railroads, embankments, and cuts is referred to as grade. While the most commonly used method of expressing slope is by percent, the advanced map reader should be familiar with other methods.

■ 50. **SLOPE IN PERCENT.**—Percent is the most convenient and commonly used method of expressing slope. A slope of 1 percent is a slope which rises vertically a distance of one unit in a horizontal distance of 100 units or one which has this rate of rise (fig. 43). A 2-percent slope rises two units, a 3-percent slope rises three units, and so on, in a horizontal distance of 100 units. The value in percent of any slope is the number of units which it rises vertically in a horizontal distance of 100 units. Thus a rise of 26.8 feet in a horizontal distance of 100 feet is a slope of 26.8 percent (fig. 42).

■ 51. **SLOPE IN MILS.**—The mil is a unit of angular measurement. A true mil is an angle which subtends an arc of unity at a radius of 1,000 units (fig. 43). A 2-mil slope subtends an arc of two units, a 3-mil slope subtends an arc of three units, and so on, at a 1,000-unit radius. The value of slope in mils

is therefore a function of the angle of slope. The vertical rise of a mil slope is not exactly equal to the subtended arc, the vertical rise of a slope of 2 mils is not exactly twice the vertical rise of a slope of 1 mil, and the variation increases with the angle of slope. However, for slopes up to 350 mils,

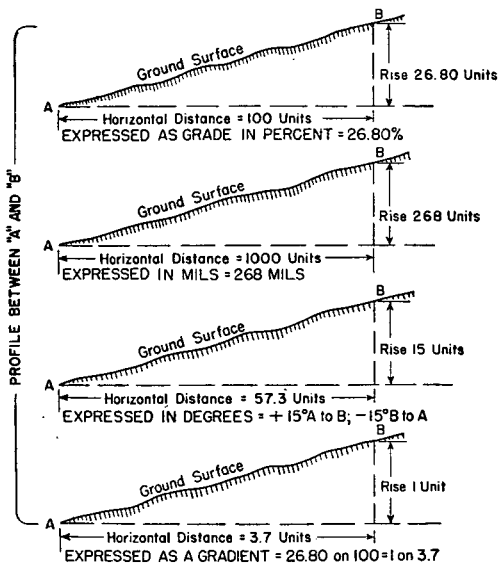
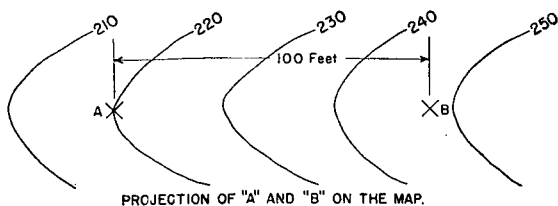

FIGURE 42.—Determination and expression of slope between two points *A* and *B* on map.

the variations are inappreciable and may be disregarded for average purposes. Thus a slope which rises 268 units in a horizontal distance of 1,000 units is a slope of 268 mils (fig. 42). Slopes may be measured with instruments graduated

in the arbitrary mil which is $\frac{1}{6400}$ of a circle. For ordinary slopes the results would not differ appreciably from the value in true mils, of which the circle contains approximately 6,283.

■ 52. **SLOPE IN DEGREES.**—Many instruments for measuring slope are graduated in degrees. The degree is a unit of angular measurement and is $\frac{1}{360}$ of the circle. A degree is an angle which subtends an arc of unity at a radius of approximately 57.3 units (fig. 43). A 2° slope subtends an arc of two units, a 3° slope subtends an arc of three units, and so on, at a 57.3-unit radius. The value of slope expressed in degrees is therefore a function of the angle of slope (fig. 42). The vertical rise of a degree slope is not exactly equal to the subtended arc, a slope of 2° is not exactly twice the vertical rise of a 1° slope, and the variation increases with the angle of slope. However, for slopes up to 20° the variations are negligible and may be disregarded.

■ 53. **GRADIENT.**—The gradient is the unit usually used in the measurement of steep slopes. It is the ratio of vertical to horizontal or of horizontal to vertical distance (fig. 42). The manner of expressing this ratio has not been standardized. Two methods are in common use as follows: A gradient of 1 on 3.7 and a gradient of 3.7 to 1.

■ 54. **SLOPE BETWEEN TWO POINTS ON MAP.**—*a.* Subtract the elevation of the initial point from the elevation of second point to determine the difference in elevation or vertical rise.

b. Scale from the map the horizontal distance between the two points along the line whose slope is to be determined and express in the same units of measurement, preferably feet.

c. Compute the value of slope from the appropriate one of the following formulas:

$$(1) \text{ Percent} = \frac{\text{difference in elevation} \times 100}{\text{horizontal distance}}$$

$$(2) \text{ Mils} = \frac{\text{difference in elevation} \times 1,000}{\text{horizontal distance}}$$

$$(3) \text{ Degrees} = \frac{\text{difference in elevation} \times 57.3}{\text{horizontal distance}}$$

(4) Gradient = $\frac{\text{difference in elevation}}{\text{horizontal distance}}$ expressed as a fraction reduced to simplest terms.

■ 55. CONVERSION OF SLOPE EXPRESSION UNITS.—*a.* Unit degree, percent, and mil slopes are illustrated in figure 43. If arc and tangent are assumed to be equal, it is apparent that the relation may be expressed as follows:

$$\text{Degree: percent: mil: } \frac{1}{57.3} : \frac{1}{100} : \frac{1}{1,000}$$

or,

$$57.3^\circ = 100 \text{ percent} = 1,000 \text{ mils}$$

Hence,

- (1) $1^\circ = 100/57.3 = 1.75 \text{ percent}$, or
 $1,000/57.3 = 17.5 \text{ mils}$.
- (2) $1 \text{ percent} = 57.3/100 = 0.57^\circ$, or
 $1,000/100 = 10 \text{ mils}$.
- (3) $1 \text{ mil} = 57.3/1,000 = 0.057^\circ$, or
 $100/1,000 = 0.1 \text{ percent}$.

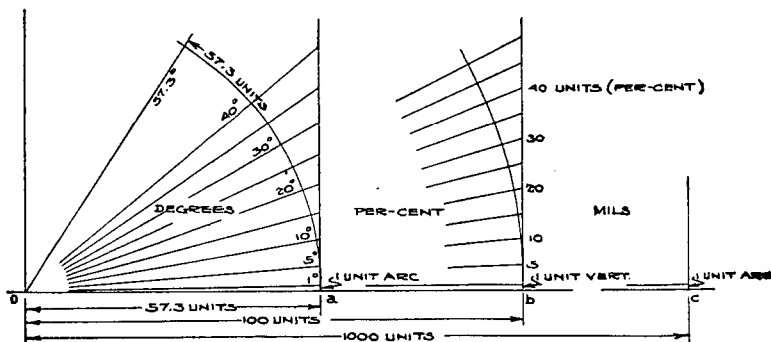

FIGURE 43.—Relation of units of slope.

b. The relations thus expressed, while suitable for conversion of angles up to 20° , are decreasingly accurate as the angle of slope increases, due to the fact that the assumption of equality of arc and tangent becomes increasingly erroneous as the angle increases. The amount of error inherent in this method of conversion for various slope angles is shown as follows:

Angle of slope		Actual per- cent of slope	Percent of slope com- puted by con- version factor
Degrees	Mils		
1	17.5	1.75	1.75
5	87.3	8.75	8.73
10	174.5	17.63	17.45
20	349	36.40	34.90
30	523.5	57.74	52.35
45	785	100.00	78.53
57.3	1,000	155.77	100.00

■ 56. **AVERAGE SLOPES.**—In determining slopes by the methods and formulas described, it should be remembered that the result expresses the slope of an inclined plane surface, whereas the actual surface of the intervening ground may vary quite irregularly up and down. It is therefore customary to refer to slopes thus determined between points over broken terrain or irregular surfaces as “average slopes.”

■ 57. **PROFILE.**—The most satisfactory way of showing the slope of the ground is by making a profile. A profile is a cross section of a specific slope or hill cut by the intersection of the earth's surface by an imaginary vertical plane (fig. 38).

a. Profile from contoured map.—Figure 44① represents a portion of a contoured map. It is desired to construct the profile of the ground represented by the map between the points *A* and *B*. Proceed as follows:

(1) Connect the points *A* and *B* by a straight line and assume that a vertical plane is passed through the line *AB*.

(2) Use a piece of ruled paper which has parallel lines equally spaced; cut or fold the paper along one of these lines.

(3) Refer to the map and determine the highest and lowest elevation along the line *AB*; number the lines on the paper to correspond with the elevations on the map beginning with the highest elevation near the top edge of the paper (fig. 44②).

(4) Place the top edge of the paper along the line *AB* and, where the edge intersects each contour, drop a perpendicular to the horizontal line on the paper corresponding to the elevation of the contour being considered. Proceed in the same

manner with each contour. The profile is then formed by drawing a line between the points of intersection of the perpendiculars with the horizontal lines on the paper. Or, use another piece of paper having a straight edge. Place the straightedge along the line *AB* and make tick marks along the edge of the paper where it intersects each contour. Draw a vertical control line on the first piece of paper which has horizontal ruled lines. Move the paper with tick marks up

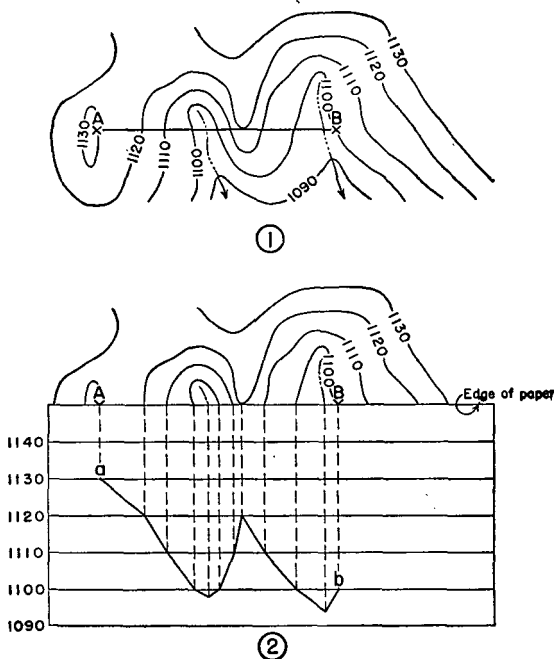

FIGURE 44.—Construction of profile.

and down the vertical control line, keeping the same tick mark on the control line. Place a point on each horizontal line where the tick mark with corresponding elevation intersects it. The profile is then formed by drawing a line between these points. The profile is then complete except between adjacent contours of the same elevation which require the determination of intermediate elevations.

(5) When the line crosses spurs or valleys, examine the map on both sides of the line, estimate the length of the crestline connecting the two adjacent contours and estimate the ratio of this line which lies on each side of the profile line. Compute the desired elevation, using the ratio of these two lengths to the contour interval. Where the line crosses a contour "circle" which forms a knob or depression, an elevation is sometimes found in this area which is of assistance in completing the profile.

(6) If a profile is desired of an irregular line on the map, such as a road or trench, divide the line into a series of sections approximately straight and plot as directed above, turning the paper at each angle to make a continuous profile.

b. Exaggeration.—For the purpose of clarity, profiles are usually exaggerated vertically in comparison with the horizontal, which for convenience is ordinarily the same as that of the map used (fig. 44②). Any selected horizontal or vertical scale may be used depending upon the material on hand and the information desired. In figure 44②, the horizontal profile lines represent 10-foot intervals; they could represent 5-foot intervals, thus further exaggerating the profile. The use of cross section paper will be found most convenient for constructing profiles, as the vertical lines aid in dropping perpendiculars to the horizontal lines.

■ 58. VISIBILITY.—A contoured map can be used to determine whether or not a point, a route of travel, or an area is visible from a given point. Because of inaccuracies inherent to map construction, it is unsafe to conclude that one given point can be seen from another given point if a profile, made from a map and between the points, shows the objective point to be only barely visible. One of the important uses made of maps by a military commander is to conceal lines of march or troop positions from an enemy's observation station. He and his staff officers are thus solving problems of visibility; by inspection of the shape, location, and elevation of map contours, they are determining approximately whether or not certain points can be seen from other points shown on the map. To be a successful troop leader, every officer and noncommissioned officer should be able to solve map visibility problems with reasonable accuracy and rapidity. Frequently the desired information can be obtained by inspection, but when

this is not possible some graphical or mathematical method should be used. The most common are the profile, similar triangle, and graphical methods. The profile method is more laborious than the others, but it is the best because of the completeness and clarity of its results, especially in determining visible areas. The similar triangle method can be used to abbreviate the profile method in many cases, especially in determining the visibility of points, short lines, and small

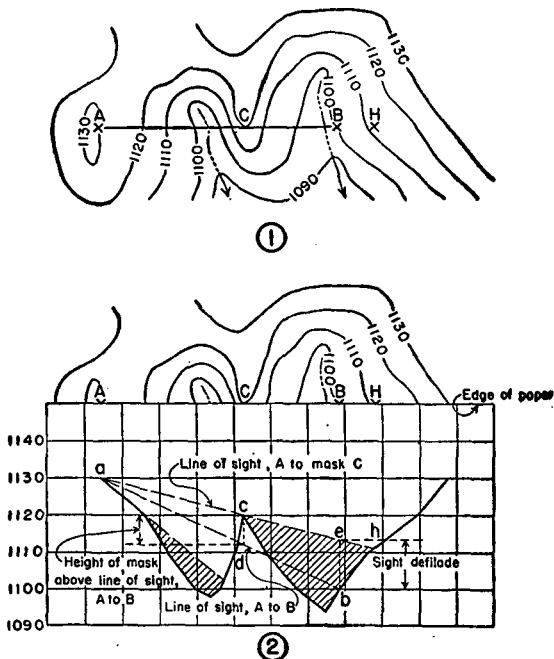

FIGURE 45.—Determination of visibility by profile method.

areas. The graphical method is convenient for checking up visibility along a line without drawing a profile. The extent to which visibility may be determined from a map depends upon the contour interval. The unrepresented variations in relief are of minor character if the contour interval is small. If the contour interval is large, unrepresented ground features may have an important influence.

a. Inspection method.—The following rules may be helpfully applied in determining by inspection the intervisibility of two points shown on a map:

(1) The points, if on opposite sides of a valley and located well above the intervening ground, are intervisible.

(2) If between two points there is a feature represented higher than both, they are not intervisible.

(3) If between the two points a feature is represented which is higher than one of the points, the points may or may not be intervisible.

(4) If the slope of the ground between the two points is convex, they are not intervisible.

(5) If the slope of the ground between the two points is concave, they are probably intervisible.

(6) When the ground between the two points is level, their intervisibility depends upon the presence of vegetation and works of man.

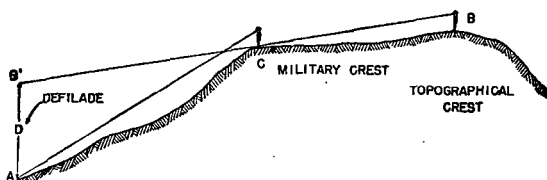

FIGURE 46.—Defilade.

b. Profile method.—(1) Figure 45① represents a portion of a contoured map. It is desired to determine whether or not *B* is visible from *A*. By use of cross section paper, construct a profile along the line *AB* as described in paragraph 57 (fig. 45②). Draw a line *ac* representing the line of sight from *A* tangent to the crest at *C*. This line strikes the ground at *h*. Therefore that portion of the ground between *C* and *H*, including *B*, is not visible from *A*.

(2) It may be noted that in the above example points *A* and *B* were both selected at ground level. Had it been desired to determine whether a man at *A*, eyes 5 feet above the ground, could see a truck 8 feet high at *B*, it would have been necessary to plot *a* in the profile (fig. 45②) with an elevation of 1,135 feet and *b* with an elevation of 1,108 feet. The result would be similar to that illustrated in figure 46. However the map reader will seldom be concerned with

the eye level of a man in a standing position. In combat the available map will probably be uncontoured or of such a scale that 5 feet would make little difference. Also the observer near combat operations will probably observe from as near ground level as possible.

c. Deflade.—In figure 46, *B* represents the topographical crest, that is, the highest crest of a hill; and *C* represents the military crest, that is, the highest crest from which the entire lower part of the hill can be observed. If an observer at *B* is unable to see an object at *A*, due to an intervening hill, spur, wood, or other terrain feature, the object at *A* is said to be "sight defladed." The intervening deflading feature is called the "mask." In figure 46, the crest at *C* interferes with the view of the foreground from the top of the hill; thus the military crest forms a mask for the topographical crest. The amount which the foreground at *A* is defladed is equal to the vertical distance *AB'* from *A* to the prolongation of the line "observer-mask." Thus in figure 45, the distance *bc*, which scales 13 feet, represents the deflade at *B* caused by the mask *C* when viewed from *A*. The term "height of mask" means the height of a mask above the line of sight between two objects at that point. In figure 45, *cd*, which scales 8 feet, represents the height of mask. Deflade problems like visibility problems may also be solved by a number of graphical and analytical methods.

d. Hasty profile.—The elementary example of deflade above may be mentally expanded to cover many cases of visibility. In a war of movement and aerial observation, terrestrial or captive balloon observation, the consequent visibility problems tend to decrease in importance. The advanced map reader may make some type of hasty profile based on the method employed in figure 47 showing the observer at *A*.

e. Defladed areas.—From any point as an origin, a line on a map can be extended in any given direction. A profile or partial profile of the terrain passed over by this line can be drawn. Such a profile makes it possible for us to ascertain just what portions of the terrain over which the line passes are visible and just what portions are not visible from the point from which our line was extended. Carrying this factor further and by making a number of profiles, each corresponding to one of a number of lines radiating from a given point, we are able to calculate just what portions (areas) of the

terrain are and are not visible from any given point. Suppose X (fig. 48①) represents the plotted location on a contoured map of an observation station. It is desired to determine the areas to the east of X that can be observed and the areas that are deflated. To solve this problem, first draw from X a number of radiating lines such as XY , XY^1 , XY^2 , and XY^3 , so that the lines cover or include as much of the area in front of X as is desired. Afterward, construct a profile corresponding to each of these lines. Three such profiles, XY , XY^2 , and XY^3 , are shown in figure 48②. Next, determine on the

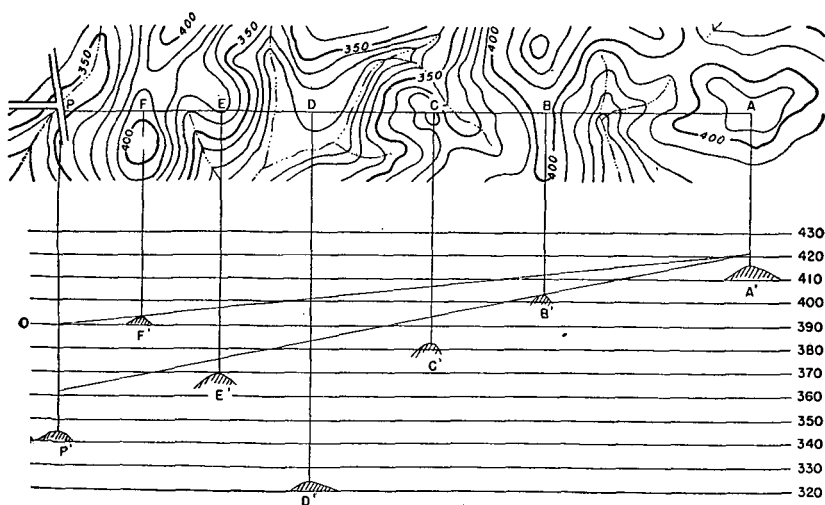

FIGURE 47.—Determination of visibility by hasty profile method.

profiles the parts of each that are deflated. This may be done by simply drawing lines from X to the various crests indicated on the profiles; as in figure 48② Y , we see, by prolonging lines from X which just touch the tops of the various crests in front of X , that those parts of the line XY between a and b and between e and f are deflated; similarly, in figure 48② Y^2 , that $a^2 b^2$, $c^2 d^2$, and $e^2 f^2$ are deflated; also in figure 48② Y^3 , that $a^3 b^3$, $c^3 d^3$, and $e^3 f^3$ are deflated. If, after solving a number of these profiles, we now plot on

our map the exact locations of the limiting points of the deflated positions of each line and then afterward join these points as in figure 48①, we can connect up areas such as those shown by the shaded lines in figure 48①. It is then known that all shaded areas, such as those shown in this figure, are not visible from the observation point at X.

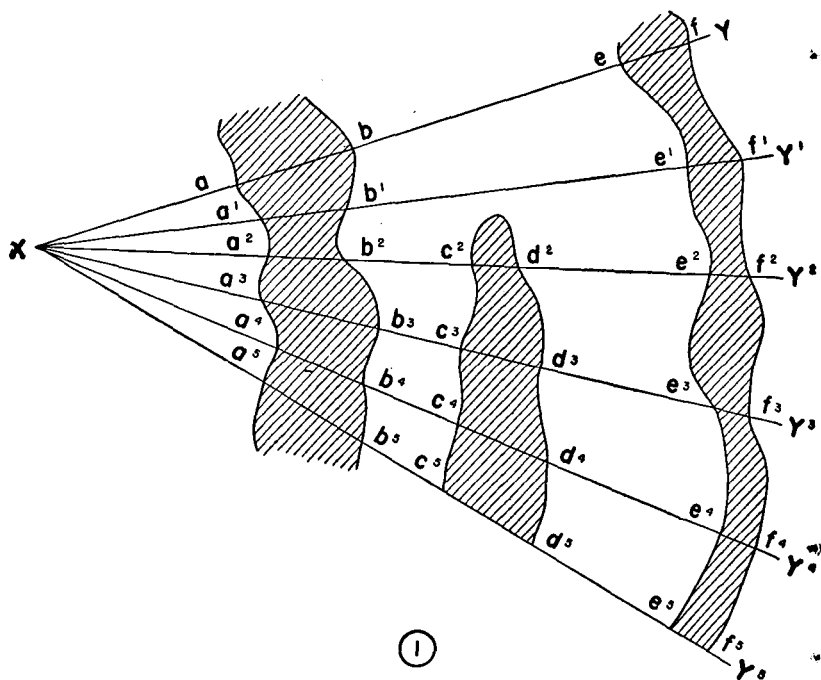

FIGURE 48.—Deflated areas.

f. Foliage.—In solving problems of visibility, there often appears an intervening woods that may or may not interfere with the visibility. Any group of trees that may possibly deflade one object from another must be carefully considered.

■ 59. VISIBILITY DIAGRAMS (fig. 49).—Visibility diagrams indicate which portions of the ground are visible and which are invisible to an observer at some definite observation post. They

are also a practical aid in identifying objects from an observation post when a good map is available. The determination by means of a map of the visibility of areas from a given point has been explained in paragraph 58, but personal reconnaissance is also necessary, because trees, hedges, and other objects not shown on the map may considerably affect the view. In constructing a visibility diagram, one should identify on the map the observation post and select a reference object. A line should be drawn joining the two and marked 0° . Lines are then set off at about 10° intervals on both sides of the

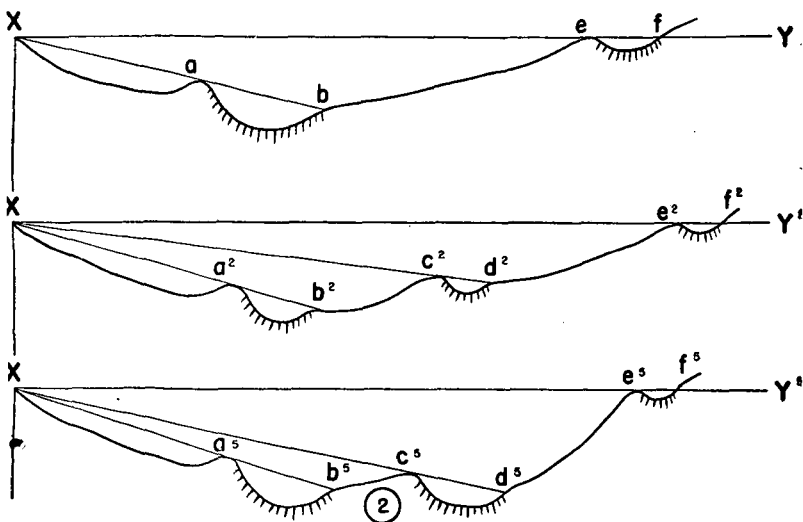

FIGURE 48.—Defladed areas—Continued.

zero line radiating from the observation post. These serve as lines of sight to be investigated. Next study the features, mark on the map those which interfere with the view, and then determine those areas which are invisible from the observer's position.

■ 60. CURVATURE AND REFRACTION.—In computing intervisibility of points on a map by the methods described herein, the ground is assumed to be flat like the map and the light rays undeflected. Errors resulting from these assumptions are

negligible in average problems on local terrain. However, the earth is a spheroid, and distant light rays are bent from their path by passage through the atmosphere near the earth. The

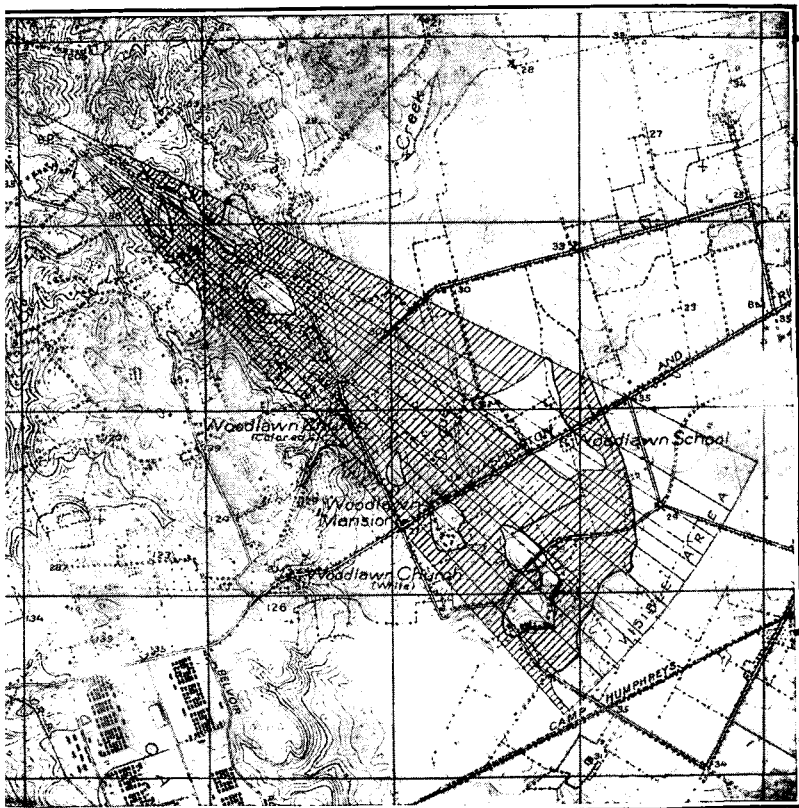

FIGURE 49.—Visibility diagram.

combined effects of curvature and refraction become appreciable at distances greater than 1 or 2 miles and should be duly considered when accurate results are desired.

SECTION VII

AERIAL PHOTOGRAPHS

■ 61. AERIAL PHOTOGRAPHS.—*a.* An aerial photograph is a perspective picture, with either a vertical or an oblique viewpoint, taken from any kind of an aircraft. Except for color values and a certain capacity of the eyes to perceive differences in relief, the aerial photograph conveys the same impression in image as received by the human eye from the same viewpoint. Since the average person is unaccustomed to the vertical viewpoint, the images of familiar objects on photographs may at first appear strange and unassociated with the objects represented. The difficulties presented in interpretation of vertical aerial photographs appear to be no greater than those ordinarily encountered in learning to read conventional military maps and are overcome in the same way.

b. The vertical aerial photograph is a valuable instrument for conveying topographic information for the following reasons:

(1) It possesses in pictorial effect a wealth of detail which no map can equal.

(2) It possesses accuracy of form.

(3) With freedom of flight, an aerial photograph may be prepared in a short time.

(4) It may be reproduced in quantity by lithography.

(5) It may be made of an area otherwise inaccessible because of either physical or military reasons.

c. The vertical photograph is inferior to a map in respect to the following features:

(1) Important military features which are emphasized on a map are sometimes obscured or hidden by the other detail.

(2) Neither absolute position nor absolute elevation can be obtained.

(3) Relative relief is not readily apparent.

(4) Displacements of position caused by relief and camera tilt usually do not permit the accurate determination of either distance or direction.

(5) Because of a lack of contrast in tone, it is difficult to read in poor light.

(6) Marginal data furnished on maps are generally lacking.

d. A large portion of the area of the United States has never been mapped. Of the area mapped, a large percentage is considered inadequately mapped because of having been mapped more than 40 years ago or to scales unsuitable for military use. The preparation of military maps under service conditions involves factors of both time and space. In consequence, it may require a period of some length before a satisfactory map can be prepared covering territory which has not been adequately mapped. On the other hand, a film may be exposed in an aerial camera over either enemy or friendly territory, the negative developed, and the photograph printed in the course of a few hours. In consequence, the value of the aerial photograph as a means for supplying topographic information before maps can be made available, or before existing maps can be revised, is readily apparent. However, because of its limitations, the aerial photograph does not constitute an ideal map, and its best use is either as a map substitute or as a map supplement. The ideal situation would include the availability of the most accurate topographic map possible, supplemented by the most recent aerial photographs.

■ 62. TYPES OF AERIAL PHOTOGRAPHS.—*a.* Aerial photographs used for military purposes are made with the Air Corps cameras listed in the following table:

TABLE IV.—*Characteristics of photographs made with U. S. Army Air Corps cameras*

Camera	Focal length in inches	Photograph size in inches	Width covered by single photograph in miles at scales of—			Flying altitudes in feet for scales of—			Flight line spacing in miles to give an overlap equivalent to 50-percent overlap on 7- x 9-inch photograph			Purpose
			1:10,000	1:20,000	1:40,000	1:10,000	1:20,000	1:40,000	1:10,000	1:20,000	1:40,000	
K-3B	8.25	7 x 9 or 9 x 9	1.42	2.84	5.68	6,875	13,750	27,500	0.71	1.42	2.84	A fully automatic aircraft camera for reconnaissance, photographic mapping, and spotting missions.
K-3B	12	7 x 9 or 9 x 9	1.42	2.84	5.68	10,000	20,000	40,000	.71	1.42	2.84	Do.
K-7C	24	9 x 18	2.84	5.68	11.36	20,000	40,000	80,000	1.42	2.84	5.68	An aircraft camera for high altitude, large-scale, spotting and reconnaissance mapping.
K-12	13.5	8 x 10	1.58	3.6	6.32	11,250	22,500	45,000	0.79	1.58	3.16	An aircraft camera, single lens, with between-lensshutter to take aerial photographs at night.

¹ Impractical flying altitudes due to airplane limits or bumpy air.

TABLE IV.—*Characteristics of photographs made with U. S. Army Air Corps cameras—Continued*

Camera	Focal length in inches	Photograph size in inches	Width covered by single photograph in miles at scales of—			Flying altitudes in feet for scales of—			Flight line spacing in miles to give an overlap equivalent to 50-percent overlap on 7-x 9-inch photograph			Purpose
			1:10,000	1:20,000	1:40,000	1:10,000	1:20,000	1:40,000	1:10,000	1:20,000	1:40,000	
T-3A (five lens).	5.9	Center, 5.4 x 5.4; composite, 32 x 32, approximately.	5.1	10.2	20.4	4,920	9,840	19,680	4.05	8.11	16.22	An aircraft five-lens camera covering a total included angle of 140° for tactical reconnaissance, mapping survey, and rough mosaics.
T-5.....	6	9 x 9.....	1.42	2.84	5.68	5,000	10,000	20,000	0.71	1.42	2.84	An aircraft camera designed for precise topographic surveying and to be used with photogrammetric equipment.

b. The photographs made with the cameras listed in *a* above are classified as follows:

(1) *Plain verticals* (fig 50).—(a) The term “plain vertical photograph” is applied to all those obtained by pointing a single-lens camera at time of exposure so that the optical axis is as nearly vertical as possible. Plain verticals are made with Air Corps K-type cameras. Since the camera film is practically horizontal, features on the ground are registered on a vertical photograph in perspective with little or no distortion in

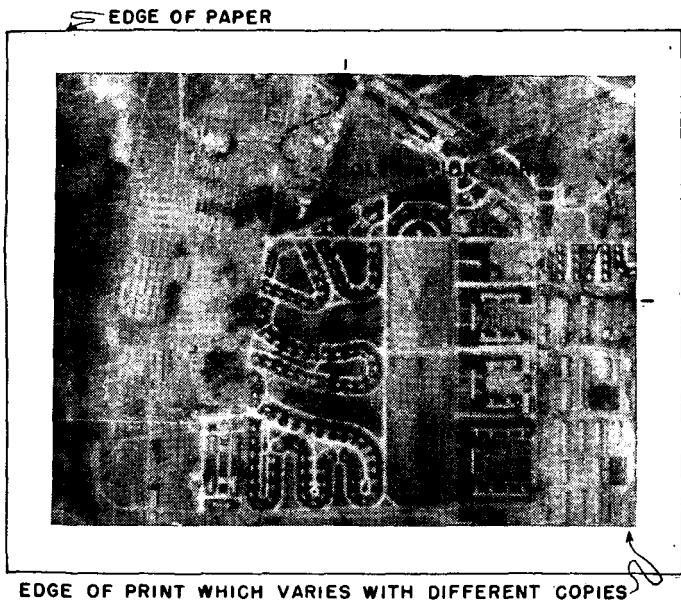

FIGURE 50.—Plain vertical made with Air Corps K-type camera.

their relative shapes and sizes. This is the most useful type of photograph for general military purposes and is the one commonly referred to as an aerial photograph.

(b) The neat lines as shown on the vertical in figure 50 are not always the same on photographs made from the same negative. In order to facilitate accurate location of points on vertical photographs, ticks or collimation marks are registered in the center of the four sides of the negative at the time

of exposure by means of a templet in the camera. The method of measuring from these collimation marks is given in paragraph 104b.

(2) *Obliques*.—Oblique aerial photographs are obtained by intentionally tilting the optical axis of the camera from the vertical. The oblique photograph is a rectangle, while the area of ground photographed is a trapezoid (fig. 51).

In making obliques the optical axis of the camera is usually held inclined about 30° to the horizontal (fig. 51) at a comparatively low altitude and such obliques are termed "low obliques." Those exposed so as to include the image of the

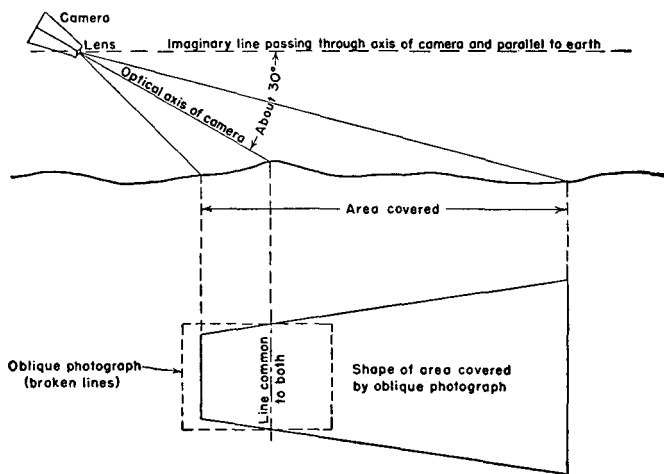

FIGURE 51.—Relative shape of area covered by oblique photograph compared to photograph itself.

horizon are termed "high obliques." Obliques are useful in emphasizing ground forms, in studying vertical dimensions of terrain features or works of man, or in interpreting detail not easily distinguished on vertical photographs when the clarity of perspective is desirable. Obliques cannot be accurately scaled. An oblique may be regarded as a highly improved and economical substitute for a panoramic sketch.

(3) *Composites*.—A composite photograph is one made by joining several photographs transformed to a common plane which have been taken at a single-camera position. Vertical

composites are made with the Air Corps T-3A type multiple-lens camera. This camera has one central chamber, the optical axis of which is held in a vertical position at exposure, and four peripheral chambers, the lenses of which

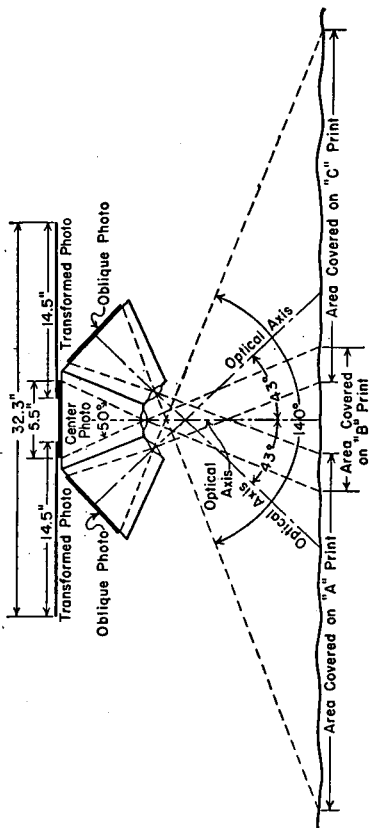

FIGURE 52.—Cross section diagram of Air Corps five-lens T-3A type camera.

are inclined at an angle of 43° with the central lens (fig. 52). The camera has a focal length of 150 millimeters (approximately 6 inches). The result of a single exposure with this camera is one plain vertical photograph which trims to 5.4 by 5.4 inches and four obliques (called wing photographs)

which are transformed to the plane of the center photograph, joined to it, and mounted to produce a single photograph in the shape of a Maltese cross approximately 32 by 32 inches (fig. 53). The transformation of the wing photographs to the plane of the center photograph is effected by means of a transforming printer which projects the wing negatives

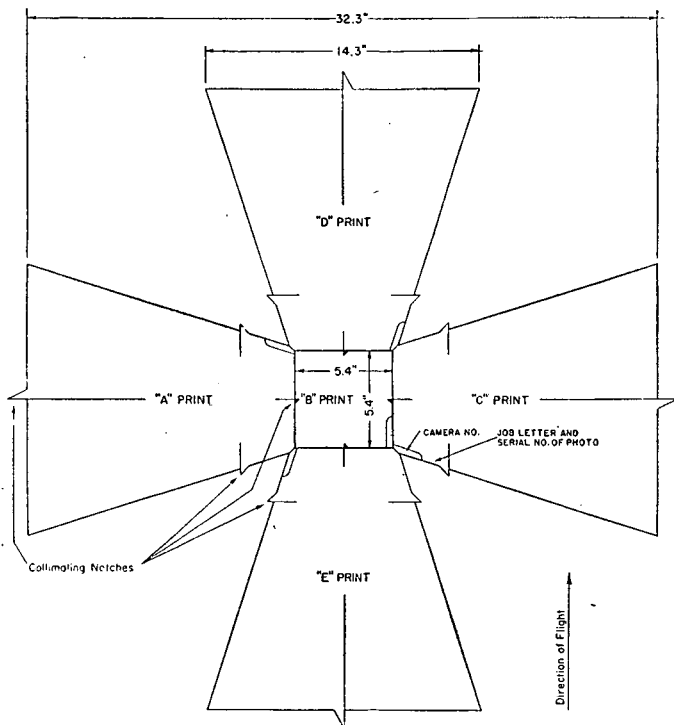

FIGURE 53.—Diagram of composite photograph made with Air Corps five-lens T-3A type camera.

to print paper which is inclined at an angle corresponding to the lens inclination in the T-3A camera (fig. 91). The term "contact prints" applies to photographs made from negatives before their transformation. Thus the contact prints of all five chambers of the T-3A camera measure 5.5

by 5.5 inches. Due to the wide angular scope of 140° and the short focal length of the T-3A camera, a single photograph from a relatively low altitude will cover an area of great width. For example, a single picture at 18,000 feet altitude gives a picture approximately 18 by 18 miles in dimension. It is this feature which makes this camera particularly adaptable to military mapping and to exploiting the detail of a large expanse of terrain from a single photograph. It has also been found possible to make a nine-lens composite (fig. 93) by taking two pictures with T-3A cameras with the vertical axis of the pictures skewed at 45° in respect to one another, thus using the wing photographs of one composite to fill the voids of the other. A photograph of a large area can be produced much more quickly by this method than by the construction of a mosaic.

■ 63. PIN POINTS.—Two or more stereoscopic photographs of an isolated object or spot constitute a pin point. Airdromes, supply depots, dumps, road crossings, bridges, or other bottlenecks on lines of communication requiring detailed study are suitable objects for pin point photographs.

■ 64. STRIPS (fig. 54).—Successive overlapping photographs made from an airplane flying a selected course line or direction constitute a photographic strip. Vertical photographs are usually taken in such strips with a constant overlap of approximately 60 percent between successive pictures forming the strip. A strip made in order to secure information regarding the condition of, or activity along, a more or less extended but narrow section of terrain, such as along a road, a railroad, a stream, an avenue of approach, a zone of action, or a stabilized front line, is called a "reconnaissance strip." When the several photographs of a single strip are joined together or mounted to form a mosaic, the result is a "strip mosaic." Strip mosaics may be either controlled or uncontrolled.

■ 65. MOSAICS.—*a. Uncontrolled mosaic.*—A mosaic is formed by joining several overlapping vertical photographs taken at different camera positions. When several photographs are oriented by matching the detail along their borders, the result is an "uncontrolled mosaic," which gives a good pictorial effect of the ground but will contain serious errors of scale

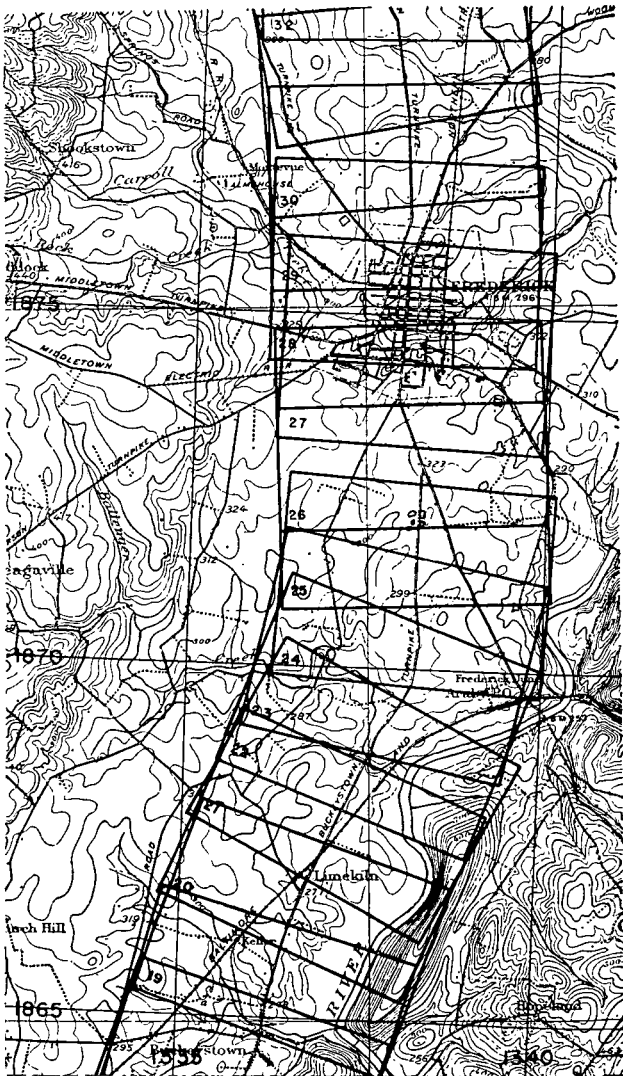

FIGURE 54.—Section of index map showing strip of K-type aerial photographs plotted on map of 1:62,500 scale.

and azimuth. While care in matching the photographs will assist in approaching accuracy, the only way that scale accuracy can be obtained is by having recognizable control on the ground.

b. Controlled mosaics.—By adjustment of vertical photographs to plotted portions of ground control points and by various other modifications of the photographs as obtained directly from the camera, errors of scale and direction inherent to single photographs and uncontrolled mosaics may be greatly reduced. If the individual prints are prepared by contact printing directly from the aerial camera negatives, they may vary considerably in over-all or average scale due to changes in plane altitude and ground elevation between successive photographs. In the preparation of controlled mosaics from such prints it is customary to determine the average scale of all the photographs by reference to ground control data and to assemble the mosaic on a control plot prepared at that scale. The technique of this operation is described in paragraph 101, TM 5-230. The variation in scale of the individual prints from the average scale of all the prints used, as well as local scale errors caused by camera tilt, will result in mismatching of detail where the prints are joined. The controlled mosaic, therefore, is frequently less pleasing in appearance than the uncontrolled mosaic; however, it is much more reliable for the measurement of distances and direction. If equipment and time are available the individual prints may be reduced or enlarged to the same scale and, in addition, the tilt errors partially or completely removed. These processes are referred to as ratioing and rectifying. If sufficient data as to ground elevation are available, local scale errors caused by variation of ground elevation within the scope of each individual print may be reduced by rephotographing each print in two or more sections. This process is called "pyramiding." Mosaics which are prepared from ratioed, rectified, and pyramided prints approach the accuracy of the best maps in representation of distances and directions. Because of the time involved in these processes as well as the necessity of obtaining extensive ground control data, the highly accurate controlled mosaic will seldom be encountered during initial stages of combat.

■ 66. **PRINT PAPER.**—Photographs may be printed on either glossy, matte, or semimatte paper of single or double weight. Unfortunately print paper shrinks in the processes of development, sometimes to a most disconcerting extent. Glossy paper gives clearest definition of detail but will receive marks or notations only in ink. Light matte paper shrinks badly and lacks sharpness of detail but will receive either pencil or ink marks. Doubleweight semimatte paper of best quality has low shrinkage, will receive pencil marks, may be used unmounted, and has clearer definition of detail than matte paper of the same weight. Changes in temperature and moisture cause glazed print paper to curl up and become refractory. In general, all prints intended for extensive use should be mounted on manila or similar paper with rubber cement. Photographs used on mapping projects are mounted on heavy cardboard or on thin metal sheets in order to reduce their shrinkage.

■ 67. **PICTURE POINTS.**—In studying one or more aerial photographs it is sometimes desirable that one be able to identify readily selected points of detail. Points thus chosen are marked on the photographs by small circles about 0.2 inch in diameter. They are known as “picture points.” By marking points in this manner adjacent detail is not obscured.

■ 68. **OVERLAYS.**—Not only is it difficult to mark on the face of a glossy photograph, but marks on the face of any photograph tend to clutter it up, obscure important detail, and diminish its usefulness. Yet it is sometimes desirable that positions of objects be emphasized or that military information such as that representing the disposition of troops, organization of ground, enemy or friendly works, supply and circulation activities, and other information shown graphically on special military maps be recorded by some means without unnecessarily damaging the print. This has been satisfactorily solved by means of overlays of high-transparency paper. A light, tough, almost colorless tracing vellum is most suitable for this work, yet any kind of transparent tracing paper which will take pencil and ink marks will answer the purpose. The tracing should be cut to fit the photograph and then carefully registered to the photograph (fig. 55). This may be done by tracing in the neat line in full or only

at the four corners, by tracing in the border ticks and the center cross, or by any convenient combination of these. The serial number of the photograph should always be traced in. Significant marginal information on the photograph should also appear on the margin of the overlay as far as consistent. The overlay should be fastened to the photograph along one edge by a little mucilage or, better still, by means of two ordinary paper clips. This will enable the overlay to be lifted at one edge for direct examination of detail without disturbing the relation of the overlay to photograph. (All

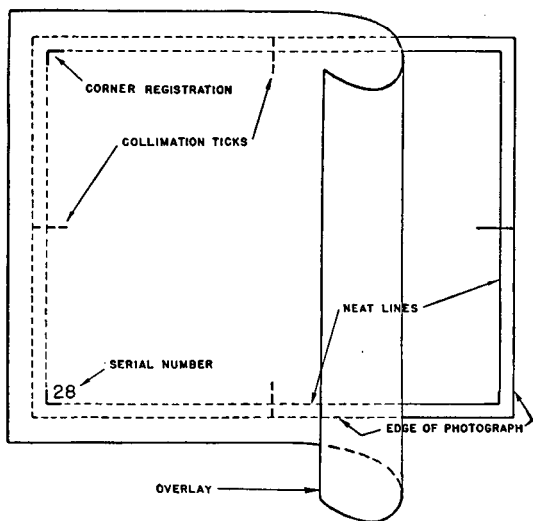

FIGURE 55.—Registered overlay.

photographs destined for extensive use should first be mounted with rubber cement on a sheet of stiff manila or similar paper cut slightly larger than the photograph and the overlay tacked to the mount as described above.)

■ 69. CONVERSION TO LINE MAP.—*a. Methods.*—It is sometimes desirable to convert a photograph to a line map. By doing so, unnecessary detail can be eliminated on the one hand and on the other hand important military features can be emphasized through their representation by conventional map symbols.

This can be done in two ways: either by tracing on a sheet of transparent overlay the topographical detail desired, or by bleaching the photograph. The latter method is seldom used.

b. Tracings.—A tracing of the detail of a good vertical photograph of average terrain in which the features are represented by map symbols in the conventional way and supplemented by useful marginal information, such as the magnetic north point and scale, becomes for practical military purposes an uncontoured map of the area photographed at the scale of the photograph. In this way every detail on the face of a photograph is preserved unblemished and yet the information recorded stands out emphatically. The original tracing may be used as a map or the tracing may be used to reproduce the map in quantity by any of the authorized reproduction processes.

■ 70. TO INDEX AND PLOT.—On receipt of one or more photographs of an area of which some sort of a map is available, examination and study of the photographs are facilitated by first outlining on the map the area or areas covered by the photograph or photographs as indicated in figure 54. This is best done by determining the scale of the photographs and using the relation to scale of map to construct a templet of tracing paper or other suitable transparent material which represents the dimensions of the photograph to the scale of the map. Thus a templet outlining the ground covered in a photograph having a scope of 7,000 by 9,000 feet on a map having an RF of 1: 20,000 would measure

$$\frac{7,000 \times 12}{20,000} \text{ by } \frac{9,000 \times 12}{20,000} \text{ or } 4.2 \text{ by } 5.4 \text{ inches.}$$

If transparent material is not available, the templet may be made from opaque material by constructing a frame inclosing a cut-out area having the scope of the photograph to the scale of the map. The templet is placed on the map and shifted about until its outline includes the details shown on the photograph. The area covered on the map is then outlined by marking around the templet. The serial number of the photograph is entered in the outline. The process is repeated for any number of photographs in hand. The result is an index sheet of the photographs showing com-

prehensively the relation of the photographs to one another and to the area.

■ 71. CARE OF AERIAL PHOTOGRAPHS.—Unmounted aerial photographs should always be filed flat and kept weighted down when exposed to changes in temperature. Never place them near a radiator, stove, or other heating device, as the photographs will curl up tightly and set in that shape. Never roll up the photographs for any purpose. When in the field, protect them from moisture as much as practicable. A heavy manila envelope is suitable for this purpose and is a convenient container.

■ 72. SOURCES OF ERROR.—Were it possible to photograph an area of perfectly flat terrain from a perfectly level plat-

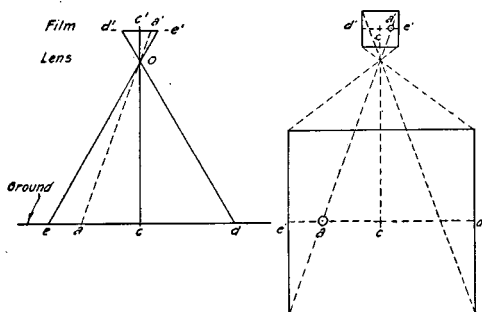
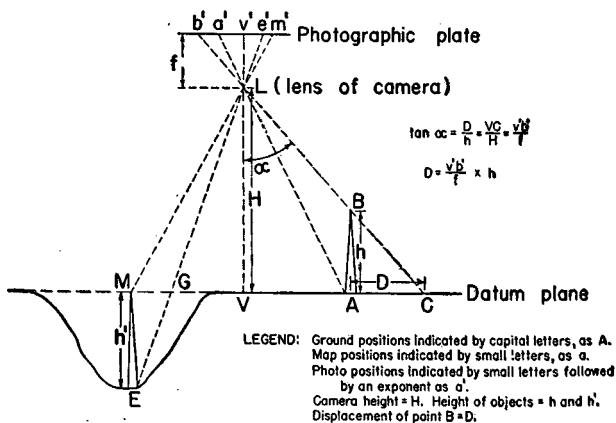

FIGURE 56.—Relation of image on photograph to object on ground under ideal conditions of level ground and camera.

form at a desired elevation, the result would be a perfect map in all planimetric detail, assuming the camera registered a true image. This may be verified by examination of figure 56. Any image a' would appear on the negative in the same relation to all other images on the photograph as the object a on the ground bears to all other objects on the ground, and similar relation would obtain between the lines $d'e'$ and de . The ground is seldom, if ever, perfectly level, and it is impracticable to fly an airplane continuously in any selected horizontal plane. Air currents and variations of air density cause the airplane to tilt about either axis and rise and fall in elevation. Distortions are also caused

by the camera lens, the shutter speed in a rapidly moving airplane, the roughness of the film, the departure of the film from the focal plane (warping of the film), and temperature and moisture changes of the film and the print paper, which may result in errors in the photographic record of the terrain. By careful photography, with good instruments and good materials at elevations of 5,000 feet or higher, all errors of sources other than tilt and relief may be neglected in practical military uses of aerial photographs. At elevations lower than 5,000 feet the aggregate effect of such errors may be very material.



①

FIGURE 57.—Diagram showing displacement of position on aerial photographs caused by relief.

■ 73. EFFECT OF RELIEF.—a. In making a map, all topographic detail is in effect projected vertically upon a horizontal plane. This results in such detail being relatively correctly located so as to permit accurate measurements of direction and distance. Reference to figure 56 will indicate that only one point c is projected vertically from the earth to the photograph. The remainder of the photograph is a conic rather than a vertical projection. The effect of such a conic projection is illustrated in figure 57①. In this figure, L represents a camera lens with

the negative of a plain vertical photograph the focal distance f above it. The line $L V$ is vertical to the earth at point V , therefore the image of V or v' is called the plumb point of

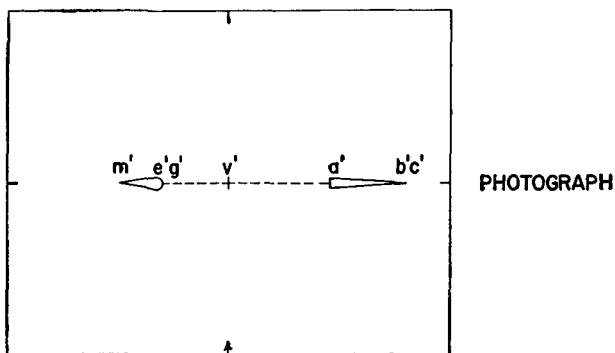

②

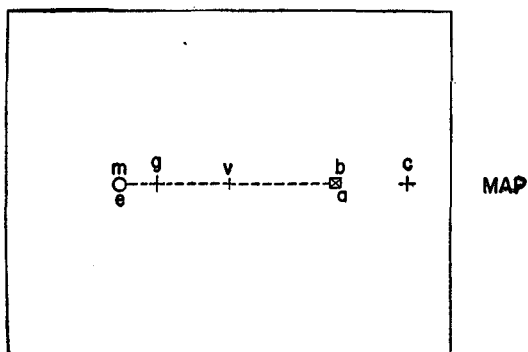

③

FIGURE 57.—Diagram showing displacement of position on aerial photographs caused by relief—Continued.

the negative. Since in this case the optical axis of the camera is assumed to be held truly vertical, v' is also the principal point of the negative as well as the plumb point. The dis-

tance LV is equal to the height of the camera lens above the ground and is designated H . If we consider the monument AB having its base in the datum plane passing through the point V and having a height of h , it is apparent from the rays of the camera, indicated by broken lines, that whereas the base of the monument point A will appear at a' on the negative, the top point B will appear at b' or in the same position on the negative that the point C in the datum plane of V would appear. The apparent displacement of B is in consequence the distance D . The displacement on the negative is the distance $a'b'$ and is outward from the plumb point v' . In the same figure it may be observed that the image of the point E , which is below the datum plane passing through the point V , is displaced inward toward v' to e' . Errors due to relief are present to some extent in all photographs of natural terrain. They cannot be eliminated by rephotographic processes and remain present in all reductions, enlargements, or transformations. In figure 57② is shown in full scale the resulting photograph of the objects shown in figure 57①, and in figure 57③, for the purpose of comparison, their vertical projection as they would be represented upon a map.

b. In figure 57① the triangles LVC , BAC , and $Lv'b'$ are similar right triangles. Consequently the following equations obtain:

$$\tan \alpha = \frac{VC}{H} = \frac{D}{h} = \frac{v'b'}{f} \quad (1)$$

Therefore

$$D = h \tan \alpha \quad (2)$$

and

$$D = h \frac{v'b'}{f} \quad (3)$$

c. From the above discussion it is apparent that—

(1) All displacements due to the elevation of a point above or below the datum plane are radial from the plumb point v' .

(2) Since $\tan \alpha$ increases as the horizontal distance of the observed point from the point V increases, from equation (2), we know that displacements are greater at the outer edges of the photograph.

(3) Similarly since $\tan \alpha$ increases as the elevation of the camera above the ground decreases, from equation (2), we know that displacements increase as the camera lens height H is decreased. For this reason it is usual when photographs

are to be used as a map to photograph terrain of average relief from heights of not less than 10,000 feet.

(4) Since in figure 57① displacements are radial from the plumb point v' , the directions of only those lines which pass through that point can be accurately measured. Errors in

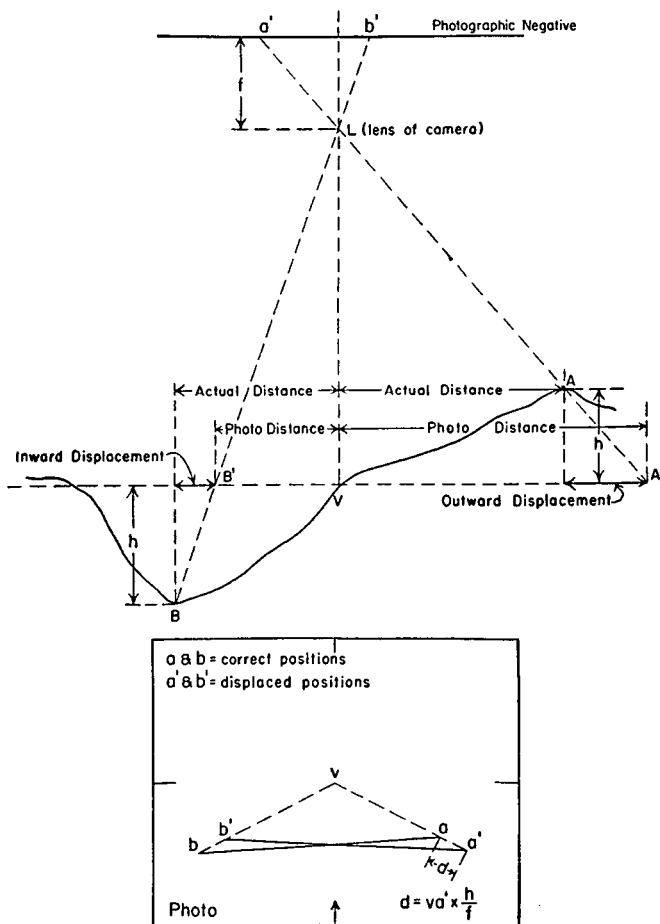

FIGURE 58.—Diagram showing errors in direction caused by relief.

the direction of other lines on the photograph can be caused by relief as illustrated in figure 58. The points *A* and *B* shown in this figure in profile are shown on the photograph (not to scale) displaced to *a'* and *b'*, respectively, because of relief, their true positions being plotted at *a* and *b*, respec-

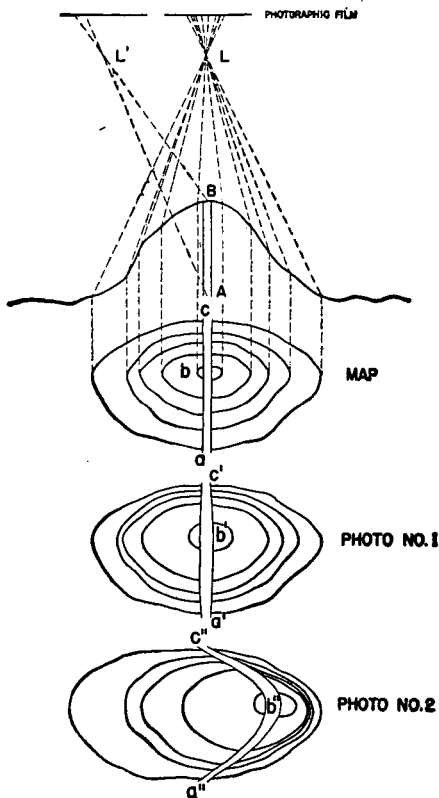

FIGURE 59.—Diagram showing effect of relief upon scale.

tively. The direction line between *A* and *B* (or *ab*) is therefore incorrectly shown on the photograph as *a'b'*.

(5) In figure 57① while *h* equals *h'* and *MV* equals *VA*, *e'm'* does not equal *a'b'*. It can therefore be stated that the scale

of all parts of a photograph of terrain having relief will not be the same. Those objects or features on high ground will be shown at a larger scale than those on lower ground. This is illustrated in figure 59 which shows the appearances of a hill when represented by a vertical projection on a map (Map), when photographed from directly above (Photo No. 1) and when photographed from a point to one side (Photo No. 2). The lens positions L and L' may be considered to be consecutive positions and the hill to appear in the overlap of the two pictures of the same strip. The difference in the appearance of the road ca is shown. Obviously such images in the overlap of successive photographs cannot be "matched" successfully as, for example, in the preparation of a mosaic. Since the images of two objects in the overlap area of successive photographs of rolling country are displaced in different degree and almost opposite direction, two photographs of such terrain cannot be accurately oriented by merely matching detail.

d. Since the distance $v'b'$ (fig. 57①) and f (the focal length of the camera) are known or measurable, the actual displacement of an object such as point B in figure 57① may be determined from formula (3), b above, when its height h above the datum plane passing through the point V is known.

■ 74. EFFECT OF TILT.—*a.* Because of the instability of an airplane, so far no means have been discovered of maintaining the camera in a truly vertical position at the instant of exposure. Level bubbles are used to indicate the tilt of the camera both in the direction of flight (sometimes defined as tip) and in the transverse direction. However, the bubbles are affected by centrifugal force as well as by gravity when the airplane is skidding, and their reactions are too slow to record sudden deviations from the horizontal. The effect of tilt is illustrated in figure 60. In this figure a section of theoretically level terrain is represented as being photographed with a camera having its lens position at L . The camera, instead of being truly vertical with its axis as the line vLV and the negative in a horizontal position, is tilted about L by an amount equal to the angle θ , and the camera axis takes the position $p'LP$. The principal or center point of the tilted negative is p' . The line from the lens vertical to the ground $L'V$ when extended upward intersects the tilted negative at

v' , the plumb point. The plumb point of the untilted negative v is also its principal or center point. The plane of the tilted negative passes through the plane of the untilted negative along a trace called the "axis of tilt." The middle point of the axis of tilt, point i' , is called the "isocenter." Since both Lp' and Lv equal the focal length of the camera, triangles $Lp'i'$ and Lvi' are similar right triangles. If the angle θ is a small angle, $i'v$ may be said to equal $i'v'$ in length. Consequently $p'i$ is equal to $i'v'$ and the isocenter i' is midway between the plumb point v' and the principal point p' . Assume that points A and B are points on the ground forming two of the four corners of a rectangle. Their images appear on the tilted negative at a' and b' , respectively, and on the untilted negative at a and b , respectively. On the depressed side of the negative the image of the point A is displaced inwardly to a' along a line passing through the isocenter i' . On the elevated side of the negative the image of the point B is displaced outwardly along a line passing through the isocenter i' . Thus the area $abcd$ registered on the untilted negative as a rectangle is registered on the tilted negative as the trapezoid $a'b'c'd'$. It may be noted that the axis of tilt is common to both the tilted and the untilted negatives. It is the line of unchanged scale on the tilted negative. It is obvious that as the angle of tilt θ decreases, points p' , i' , and v' approach coincidence. When the tilt is slight the distances $p'i'$ and $v'i'$ become inappreciable at the scale of the negative. This same relation holds true for the corresponding photograph which is shown by a broken line at the same focal distance below the lens L . However, in the photograph the point A would be registered on the elevated side, for which the angle of tilt θ is given a positive (+) value. On the other side of the photograph the tilt would be considered negative in sign.

b . It is also to be observed that the angles at i' formed by the lines radiating from i' to a , b , c , and d , respectively, remain unchanged by tilt. The scale of a tilted negative decreases progressively from i' outwardly in the direction of tilt on the depressed side and increases progressively outwardly in the direction of tilt on the elevated side. Therefore, lines parallel to the axis of tilt are lines of uniform scale but the scales of no two such lines are the same. For the

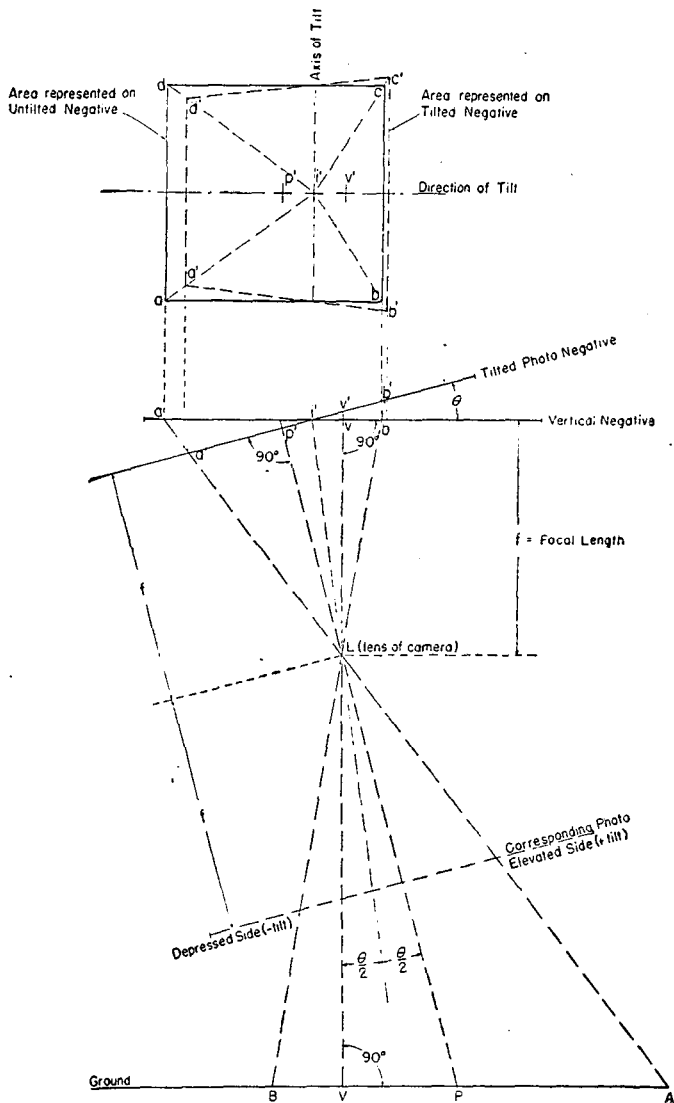

FIGURE 60.—Diagram showing effect of tilt.

same reason diagonal lines joining points unequally distant from i' are not lines of uniform scale and do not represent true direction.

c. The displacement due to tilt of casual points and directions is illustrated in figure 61. The images of the ground points W , X , Y , and Z are registered at w' , x' , y' , and z' , respectively, on the tilted photograph negative, whereas the correct positions of the points would have been shown on an untilted photograph at w , x , y , and z , respectively. The displacements of position and direction are apparent.

■ 75. COMBINED EFFECT OF RELIEF AND TILT.—Many puzzling discrepancies are sometimes found on close examination between the map and the vertical photograph, but when understood they will rarely present insuperable difficulties to the map and photograph reader. It has been seen that taken separately the effects of tilt and relief follow simple rules. However, it is their combined effect which is the cause of errors appearing on aerial photographs. These may be cumulative (fig. 62) or may be compensating. The displacements due to relief are radial along a line passing through the plumb point, and those due to tilt are radial along a line passing through the isocenter. The correction of the combined effect is simplified, however, in that these two points approach coincidence at the principal or center point of the photograph with decrease in the angle of tilt. It is therefore possible to assume in the case of slightly tilted photographs that for all practical purposes both displacements are radial along a line passing through the principal or center point. This assumption is made use of in the radial line method of restitution explained in paragraph 113. It does not obtain when the amount of tilt exceeds 3° . However, extensive tests have indicated that few photographs made by experienced aviators in favorable weather are tilted in excess of 3° and that the majority of the photographs are tilted less than 1° . In plain vertical photographs of average tilt taken over gently rolling or fairly flat terrain, the combined effect of errors of relief and tilt over the center half is negligible for ordinary use as a map substitute (precise measurements excepted) and is rarely prohibitive in the marginal portion. Such photographs if tilted in excess of 5° or containing a relief range in excess of 500 feet are

unsuitable for general use as contemplated herein because distances and angles measured on the photograph, as is ordinarily done on a map, will be appreciably inaccurate.

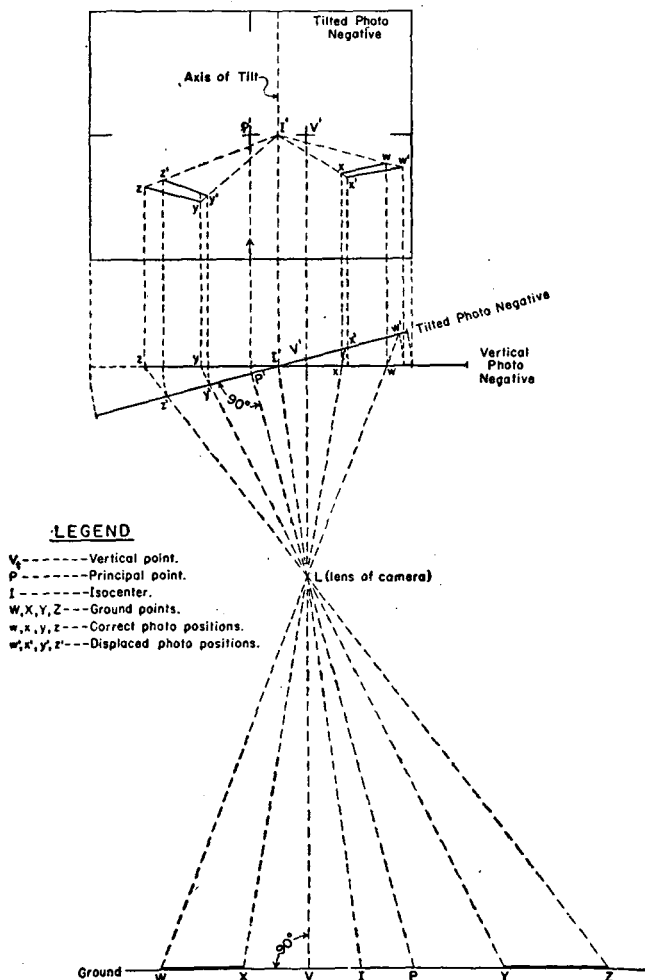

FIGURE 61.—Diagram showing displacement of position on aerial photographs caused by tilt.

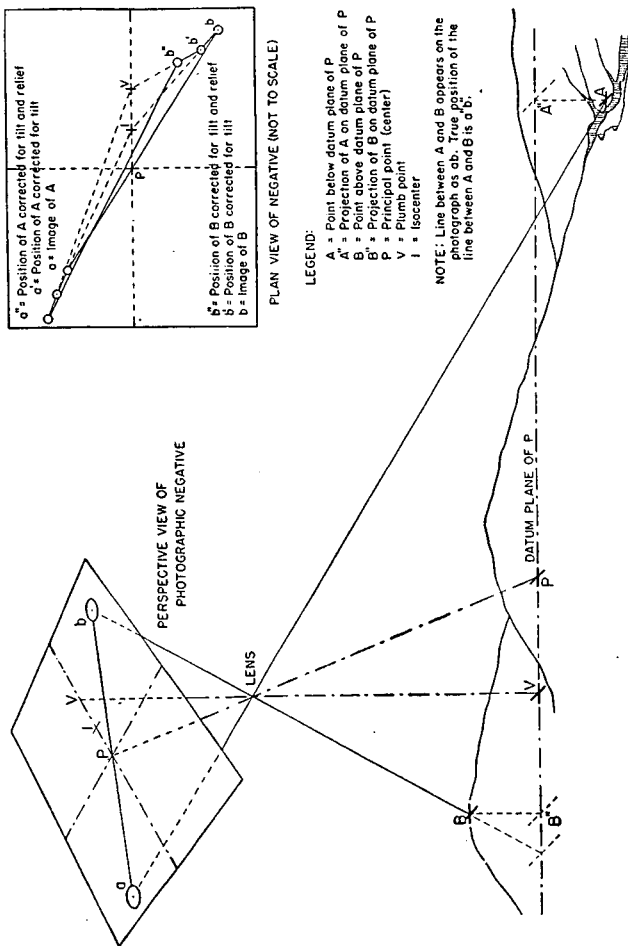

FIGURE 62.—Diagram showing displacement of position on aerial photographs caused by combined effect of relief and tilt.

SECTION VIII

IDENTIFICATION OF TERRAIN FEATURES ON SINGLE PHOTOGRAPH

■ 76. GENERAL.—*a. Topographical identification.*—Topographical identification is the art of identifying visible features of terrain from their images on a photograph, or in deducing the existence of hidden features by their characteristic effects on images of visible features. For instance, roads, railroads, houses, woods, brush, orchards, cultivated lands, etc., are easily identified, and in general closely resemble the conventional signs by which they are represented on maps. On the other hand, the existence of a small stream in heavy woods is inferred by the irregular variation in the density of the woods and association with visible parts of the local drainage net. Likewise, the existence of an invisible stream may be inferred by the narrow irregular band of brush or trees through cultivated lands, or the existence of a fence or land subdivision from a straight hedge line. Successful identification implies familiarity with the characteristics of vertical images and intelligent association of visible effects with hidden causes.

b. Tactical interpretation.—Tactical interpretation of aerial photographs is an art highly developed by the staff intelligence personnel of all armies during the World War. It is properly a specialty of the intelligence sections of staffs; is an advanced phase of aerial photograph reading; and implies tactical experience and knowledge. For treatment of this subject, see FM 30-21.

■ 77. MARGINAL DATA.—As aids in reading and use, aerial photographs to be used individually will have information along the black strip at the bottom, reading from left to right as follows:

a. An arrow $\frac{1}{2}$ inch in length in the lower left corner of the negative indicating north, with letter N superimposed over the center of the shaft.

b. Name of locality or nearest locality.

c. Approximate military grid coordinates of the center of the photograph.

d. Scale of the photograph expressed as a representative fraction, in case of a vertical; altitude above the ground in feet and focal length of camera, in case of an oblique.

e. Hour.

f. Date arranged in the following order: day, in figures; month, in letters; and year, in figures.

g. Designation of squadron.

h. Serial number of negative. For example, the following is the legend on a vertical:

Saranac, N. Y.-(321-437)-1:20,000-(2:00 PM)-(24-Aug-40)-97th-M5.

■ 78. **ORIENTATION.**—The pictorial effect of an aerial photograph is influenced by shadow. In order that this effect will aid rather than hinder the interpretation of the photograph, the lighting conditions as they occurred in nature at the time that the photograph was taken should be simulated. To do this the photograph should be oriented so that the rays of light from a window or an artificial source strike the photograph from the same general direction as did the sun's rays on the ground. If this is not done, the effect of the light is contrary to that of nature and high ground appears to be a depression and vice versa, to the confusion of the interpreter (fig. 63).

■ 79. **IDENTIFICATION OF OBJECTS.**—The identification of objects on an aerial photograph or a mosaic is effected through four means as follows:

a. Shape of object.

b. Relative size of object.

c. Tone, or shade of gray, in which object appears.

d. Shadow which object casts.

■ 80. **SHAPE.**—On a photograph taken from the ground or on an oblique, objects appear in profile as is customary for the eye to view them. On a vertical photograph they appear in plan. A knowledge of their characteristic appearance is best gained by comparison of the photographic image with the object on the ground or with the map symbol representing it.

■ 81. **RELATIVE SIZE.**—The relative size of an object is a valuable aid in reading photographs. A truck on a road

gives an idea of the road width; outlying residential houses may be compared to warehouses, etc.; and in many parts where farming is intensive, the size of farm blocks offer a means for comparing sizes of objects.

■ 82. TONE.—The shade of gray in which an object appears is known as the tone of the image. It is due almost entirely to the amount of light which is reflected by the object to the camera. The more light reflected by the surface of an object toward the camera, the whiter it appears on the photograph. A surface which reflects no light toward the camera appears black on the photograph. The amount of light reflected depends on the nature and texture of the surface and the angle at which it reflects light toward the camera. Therefore the tone of an object on two consecutive photographs of a strip will vary because the reflection of the sun's rays on the two photographs will not be at the same angle. Because of the preponderant effect of texture, the tone of objects will often appear much lighter or darker than the color would appear to warrant. The following tone effects should be understood:

a. A smooth surface is a good reflector of light and appears white when the camera is in that position which catches the reflected rays of the sun. However if the light is not reflected to the camera, a smooth surface will be dark. The image of smooth water, which is an example of such a surface, is found sometimes to appear to be light and sometimes dark depending upon the angle at which the sun's rays fall upon it.

b. The majority of natural surfaces reflect light in all directions and appear intermediate in tone because some of the reflected light finds its way to the camera.

c. Since not all reflecting surfaces, for example, roofs and sides of slopes, are level, there may be some, no matter what the position of the sun, which will reflect the light and appear white.

d. Rough surfaces reflect light at many different angles in an amount depending upon the nature of the object. Their tone is usually an intermediate one. Roads, unless tarred or oiled, are by nature good reflectors of light and possess a surface sufficiently rough in texture to reflect light through a wide range in position of the sun. As a result, roads almost invariably show as a light line.

e. Any change in the texture of a portion of an object is evident on an aerial photograph through a resulting difference in tone when compared with the other portions. Thus the trampling of a field of grass by walking across it alters the reflection of light and registers a difference in tone on a photograph.



①

FIGURE 63.—Effect of shadow upon perception of relief. The two illustrations are an identical photograph differing by 180° in orientation.

■ 83. SHADOW.—The effect of shadow is a most important consideration in the interpretation of vertical aerial photographs and mosaics. The shape of an object is often more discernible by the shadow it casts than by either its image or its tone. This is because its vertical dimensions shown by the shadow may be more characteristic than its horizontal

dimensions which are shown by the image; or its tone may blend into the surrounding landscape while its shadow may stand out in contrast. The effect of shadow is an index to valuable military information such as the approximate height, the number of spans and type of a bridge, the height of trees, the shape and height of buildings, and the depth of cuts,



②

FIGURE 63.—Effect of shadow upon perception of relief. The two illustrations are an identical photograph differing by 180° in orientation—Continued.

pits, and quarries. A shadow will sometimes make the general character of relief discernible but, as has already been mentioned, if the photograph is not held so that the direction of the shadows coincides with the observer's sense of direction of the source of the light, the effect is reversed and a depression will appear to be an elevation. This is illustrated in figure 63.



① Summer.

FIGURE 64.—Effect of season.



③ Winter.

FIGURE 64.—Effect of season—Continued.

■ 84. PHOTOGRAPHY.—In order to reduce the length of shadows, photography is usually undertaken when the sun is 3 hours or more above the horizon. Light may be diffused by excessive moisture or dust in the atmosphere, resulting in lack of definition in the prints. Intense light produces sharp definition of detail and sharp shadow contrasts. The high-angle sun around noon produces the least shadow effect, and photographs taken around noon are best suited for study of detail through forest canopies and for depicting exact outlines. The low-angle sun, morning or afternoon, produces the greatest shadow effect. Low-lying solid cloud masses effectively prohibit high-altitude photography, and broken clouds seriously interfere by producing white spots on pictures and cloud shadows on the terrain.

■ 85. EFFECT OF SEASON (fig. 64 ① and ②).—Seasonal changes produce corresponding characteristic changes in the physical appearance of terrain on aerial photographs. In summer, deciduous forests show impenetrable expanses of luxuriant treetops, resembling the effect produced by the conventional signs used on some topographical maps. Lesser detail of the terrain is largely hidden. The line of demarcation between forest and open areas is sharply and exactly defined. In winter, deciduous forests on large-scale photographs show a confusion of tree skeletons through which the light penetrates to reveal roads, trails, drainage, and relief with good effect. The line of demarcation between forested and open terrain is not so clear, however, as on small-scale photographs; the tangle of tree trunks and limbs imparts a blurred appearance to the terrain. The appearance of grass and farm land on aerial photographs changes with the seasonal state of culture. Streams in the wet season are broad and may cover extensive back-water areas in flood. The same streams in the dry season may show dry beds or insignificant threads of water. Snow in winter may completely blanket an area which is normally rich in detail.

■ 86. TOPOGRAPHICAL FEATURES.—*a.* Woods on aerial photographs appear as dark masses of irregular outline. The exact shape, size, and density are much more clearly and accurately shown than on the average topographical map. The seasonal characteristics are reflected in the photographs.

In winter photographs of deciduous forests, the leafy canopy is absent, exposing substantially all ground detail which would be wholly or partially obscured in summer photographs of the same forests. Evergreen forests show dark and dense in all seasons (fig. 65 ① and ③).



① Woods, improved and unimproved roads, gravel (or borrow) pit in left foreground.

FIGURE 65.

b. Brush appears similar to light woods but may be distinguished by its sparse character and lack of height (fig. 65②).

c. Bodies of water have a characteristic appearance appreciably lighter or darker than the surrounding land, de-

pending upon the amount of reflection from the surface when the photograph was made (fig. 65③).

d. Streams appear in characteristic wavy traces and show presence of water by darker or lighter lines. In woods, the exact location of small streams may be difficult if not im-



② Stream partly obscured by woods.
FIGURE 65—Continued.

possible to determine except by reference to a map or inspection of the ground. The visible evidences of such streams are breaks or variations in density of the forest canopy (fig. 65②, ⑤, and ⑦).

e. Cultivated fields show clearly as rectangles or irregular figures of definite shapes and shades. The nature of the

crop usually cannot be determined from the face of small-scale photographs but may be recognized on large-scale photographs. Grain in shocks is conspicuously shown by regularly spaced dots in a lighter background. Fields from which crops have been harvested show light areas. Fields



③ Cultivated fields, woods, orchard, and river.
FIGURE 65—Continued.

with heavy standing crops and grasslands show dark areas. On large-scale photographs they present rough surface appearances. Plowed fields show distinct shading (fig. 65③ and ④).

f. Fences, on large-scale photographs, are distinguished by shadows of the fence posts. On small-scale photographs,

fences are inferred from hedge lines, section lines, outlines of cultivated lands, and the characteristics of paths, trails, and roads (fig. 65ⓐ).

g. Roads show up in general as light lines or narrow bands—the more used the lighter the appearance. Improved roads



ⓐ Railroad, including main line, branch line, siding, and railroad cut.

Figure 65—Continued.

show regularity in width, long tangents, and easy curves. The hard surface is clean-cut in outline and may show dark along the middle from the oil drips of automobiles, and light along each edge. Unimproved roads are of irregular width and trace, and may contain sharp turns. Evidence of condi-

tion of road surface is usually apparent from blemishes, shadows, and color variations (fig. 65④ and ⑦).

h. Railroads show straighter, darker traces than highways, have fewer changes of direction, long easy curves, and heavy cuts and fills (fig. 65④ and ⑤).



⑤ Railroad bridge over a small stream (at left), overpass (at right).
FIGURE 65—Continued.

i. Small bridges may be looked for at all lesser stream crossings and may be identified by the narrowing of roadbed and shadows cast.

j. Buildings show as indistinct roof images and are sometimes difficult to distinguish from blemishes on prints. The

decisive evidence of the presence of a building is provided by its shadow. Groups of buildings may be blurred by the collective shadow effect. The shape of the shadow is an index of the type and size of the building. The building site is usually the terminus of a road or path (fig. 65③ and ④).



⑥ Improved and unimproved roads, trails, and paths.
FIGURE 65—Continued.

k. Villages and towns are easily distinguished and appear much the same as they do on maps.

l. Trails and paths appear as irregular white bands, lightness and width indicating degree of use (fig. 65⑥).

m. Works of man appear in straight lines, in geometrical form, in unnatural regularity, and relation (fig. 65⑦).

n. Natural features occur in irregular lines, without precision of form and relation.

■ 87. **MILITARY FEATURES.**—Military works and activities produce characteristic images and terrain effects which make aerial photographs one of the most important sources of

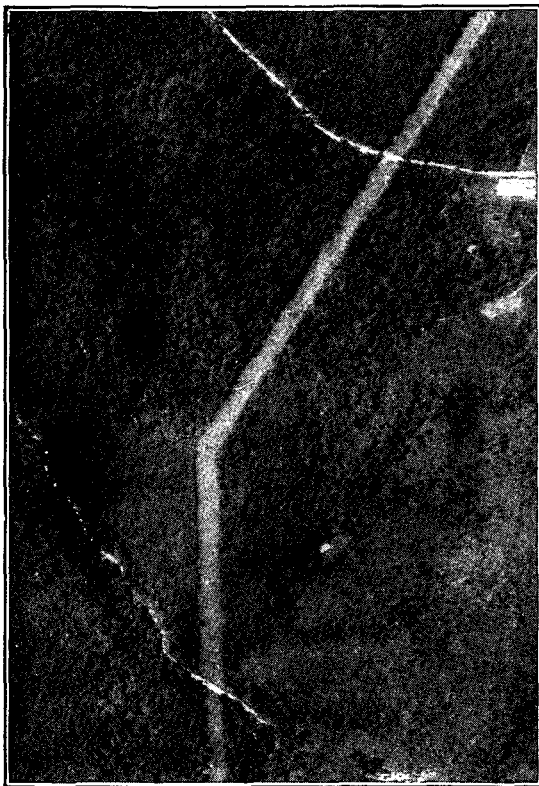

⑦ Slashing for high tension electric power line, stream, and road.
FIGURE 65—Continued.

combat intelligence. FM 30-21 covers this highly important subject.

■ 88. **RELIEF.**—Single vertical photographs afford only certain clues in regard to relief. Figure 66 represents an untrimmed

vertical photograph from the B (central) chamber of a T-3A camera. Compare this photograph with a sketch of the same area shown in figure 67. The most important clues are those afforded by streams and ponds which indicate low ground. Other clues indicating relief are the alinement



FIGURE 66.—Photograph made with B (central) chamber of Air Corps five-lens T-3A type camera.

and grading of roads and the shadows cast on and by slopes; these, especially the latter, may be very misleading. Direct evidence of relief can be obtained only by stereo examination of an overlapping pair of aerial photographs.

SECTION IX

STEREOVISION AND EXAMINATION

■ 89. STEREOVISION.—*a. General.*—The ordinary vertical photograph has a flat appearance, which makes it difficult to distinguish between hills and valleys. If two overlapping vertical photographs are viewed either with the naked eyes or

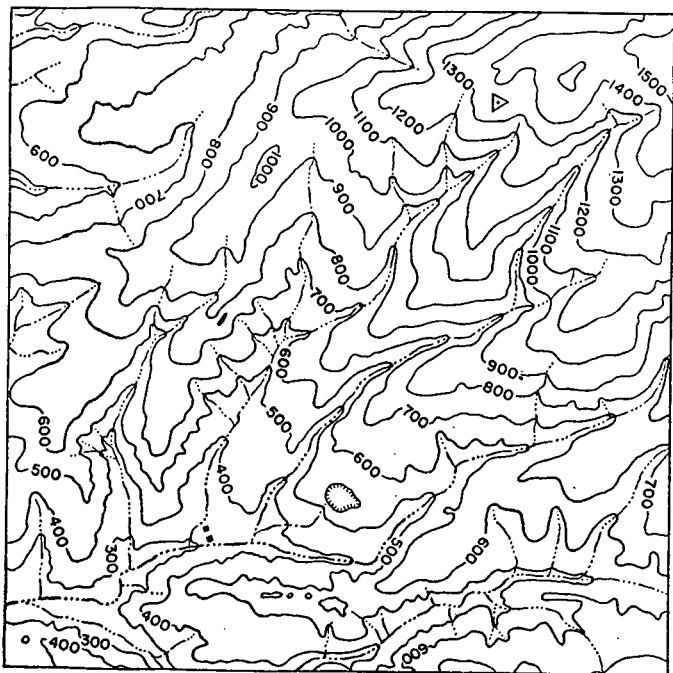

FIGURE 67.—Sketch of area shown in figure 66, representing relief (other detail omitted).

with some type of stereoscopic instrument, the observer will get the effect of depth or relief. This type of study gives valuable training in the understanding and reading of single vertical photographs and photomaps. There are several methods which will assist in acquiring this ability and each individual should experiment until he finds the method which

gives the best results. This ability comes very quickly to most men; others will have to use patience and perseverance to obtain it. Experience with large groups of men reveals that anyone with eyes good enough to be in the Army can acquire the ability to see stereoscopically. Stereo studies properly done put no strain on the eyes, and some oculists even prescribe similar exercises to strengthen the eyes. However, when magnifying spectacles are used, they should be removed from the eyes before looking up from the photographs.

b. Stereogram.—A pair of small pictures, geometric figures, or portions of two overlapping aerial photographs arranged for stereovision is called a stereogram. Figure 68 shows four simple stereograms; figures 69 and 70 show portions of aerial photographs arranged as stereograms.

c. Stereo-pair.—Two vertical photographs of an object or group of objects taken from the same elevation from two different camera positions and with an overlap of not less than 60 percent nor more than 75 percent are known as a stereo-pair (see fig. 72).

d. Stereo-triplet.—Three verticals such that the entire area of the center picture is overlapped by the other two is called a stereo-triplet. For methods of mounting, tilting, marking, etc., see FM 30-21.

e. Anaglyph.—An anaglyph is a form of stereogram on which a picture is formed by almost superimposing an image in red over one in blue to secure stereo or perspective effect when observed through an anaglyphoscope—spectacles with one blue and one red lens. Several methods of indicating perspective relief of the terrain are in use. With aerial photographs available, the simplest method is the overprinting in two colors of a stereo-pair. Another method, the anaglyph of the contoured map, is the result of an expensive and time-consuming process. The polaroid anaglyph is still another form of portraying three dimensions. The anaglyph, as a rule, gives less detail than a stereo-pair of the same scale. However, the anaglyph is of great value in stereo instruction. For an illustration of an anaglyph, see TM 5-230.

■ 90. STEREOVISION EXERCISES.—*a. Preliminary exercises.*—Experience has shown that the best method of quickly ac-

quiring the ability to see photographs stereoscopically either with the naked eyes or with an instrument is to practice certain preliminary exercises. Figure 71 illustrates a simple device which can be quickly and easily prepared by the student for use in these exercises. Cut two pieces of white cardboard each 5 inches long by 3 inches wide. At the exact center of each piece of cardboard describe a circle exactly $1\frac{1}{2}$ inches in diameter. Number these pieces of cardboard 1 and 2, respectively. On card No. 2 draw a smaller circle exactly $\frac{3}{8}$ of an inch in diameter, with its center $1\frac{1}{8}$ inches to the left of the center of the large circle. Draw a cross $\frac{3}{8}$ by $\frac{3}{8}$ inch with its intersection $1\frac{1}{8}$ inches to the right of the center of the large circle. Label the reverse of card No. 1 as No. 4, and the reverse of card No. 2 as No. 3, and draw a line on each as illustrated in figure 71. Now cut out the large circle from each card. Do *not* cut out the small circle on card No. 2. Sit in a chair and look across the room at a fairly distant wall. Hold card No. 1 about 6 inches in front of the eyes, with the hole directly in front of the bridge of the nose. Look at the wall, through the hole, with both eyes open. Note that there are apparently two distinct holes in the card. This is the first step of stereovision. Take card No. 2. This card is like No. 1 except that it has a circle printed on one side of the hole and a cross on the other side. The method of using this card is exactly the same as No. 1. However, when you see the two holes you will also see between them the circle with the cross inside. Concentrate your eyes on the image. Twist the card and notice how the cross moves with relation to the circle. You will note that if the cross moves up, the circle moves down and vice versa. The holes may appear to be slightly overlapping at some times; at other times the circle and the hole may appear to be floating in the holes entirely off the card. Try holding a strip of paper between the two holes with the images of the circle and the cross on the strip. While you are seeing the hole double, move the paper nearer and farther from the eyes. Watch what happens to the image. When you can see these images, and thus see double, you have accomplished the necessary muscular control to read a stereogram. Practice with this card until you can see these images without effort. When you have acquired skill with No. 2, go on to Nos. 3 and 4. These are used together, No. 3 on the left, No. 4 on the right.

Place the two cards together with the black lines matched and hold them against the nose with the holes in the same position as if they were glasses. The holes should be the same distance apart as your eyes. The distance is normally about 2.6 inches, center to center. Looking through the holes, focus on a distant object. Now move the cards in the direction of this object until they are about a foot from the eyes. You will now see three holes with the object viewed in the center hole. Remember during this that the eyes *must* remain focused on the distant object. When the three holes are seen, the eyes are in the proper position for stereovision. The images of the three holes appear although you are not looking at them. You are looking at the distant object. This is similar to lining up your sights on the target range. You are focusing at the front sight but you see both the bull's-eye and rear sight. Practice at this exercise will enable the three holes to be seen without first focusing on a distant object. This means that you have acquired sufficient muscular control over your eyes to see stereoscopically.

b. Fusion exercises.—The next step is practice in fusing two pictures. In figure 68 the drawings can be fused as follows. Focus the eyes on a distant object. Without changing the focus, bring figure 68 in front of the eyes and about 6 to 10 inches away. As you continue to gaze at the drawing the dots will merge until apparently you have one dot on one figure. You will still get three images but the center one is the important one on which you should fix your attention disregarding the other two outside images. Now see what effect you get with the pair of dots below on figure 68.

c. Exercises for perception of relief.—Figure 68 shows two views each of two geometric figures. Using the same methods as in *b* above, fuse the first pair of drawings, which should cause you to see a square pit with a pyramid sticking up out of the bottom. In other words, instead of a flat geometric drawing, you are seeing a three-dimensional picture. Fuse the other pair of drawings and observe the results.

d. Study of stereograms.—Figures 69 and 70 are stereograms. To see these properly, use the same methods as prescribed above. First, fuse the square points marked *A* in figure 69. You will again get three images, but the center one is the one on which to focus, and is the one on which relief will be visible. If you have difficulty seeing this center image clearly,

hold a piece of cardboard vertically up to the nose so that it is perpendicular to the pictures and one edge of the cardboard lies on the line dividing the two pictures of the stereogram. This will eliminate the two outside images and leave only the center image. Focus on this, and the trees and buildings will appear to stand up high above the page. Practice with figures 69 and 70.

e. Cross-eyed stereovision.—While the great majority of people can see stereoscopically by the method described above, there are a few who may be able to see better by using another method. The difference lies in the fact that in the parallel vision system described above, the right eye looks at the right picture and the left eye at the left picture. In this second method, the right eye looks at the left picture and the left eye at the right picture or in other words with the eyes crossed. In using the stereograms, the relief will be reversed with this method. The hills will look like valleys and the valleys like hills. Therefore, for study of overlapping pairs, the right and left pictures should be placed on the left and right, respectively. This will give the stereo observer using the cross-eyed method the proper effect of relief.

■ 91. STEREOSCOPES.—*a. Types.*—The stereoscopes used for the interpretation of aerial photographs may be classified as mirror, lens, or prism types. The mirror stereoscope (fig. 74) possesses the advantage of a large field of view and is considered to be the most adaptable for general military use. The lens stereoscope (fig. 75), although affording only a limited field of view, has the advantage of permitting the introduction of magnification. The prism stereoscope (fig. 76), which is larger and more expensive than either of the other two types, possesses the advantage of permitting a wide separation of the two overlapping photographs and is therefore particularly suitable for examining T-3A photographs. The instrument illustrated has a magnification of 2 power.

b. Improvised stereoscopes.—A suitable stereoscope for interpreting detail on aerial photographs may be improvised by means of two magnifying glasses of equal power (fig. 77). One glass may be held in each hand and stereoscopic fusion obtained by looking through the inner half of each lens. For more prolonged inspection the glasses may either be

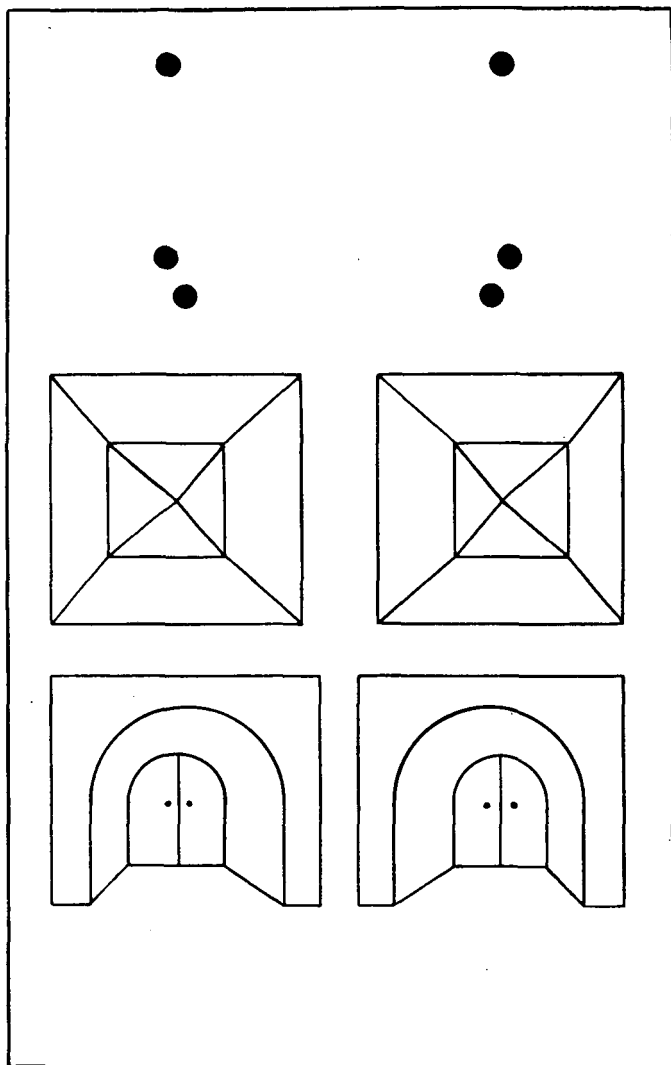

FIGURE 68.—Simple stereograms.

supported on an improvised stand or, if of appropriate size, may be mounted in a spectacle frame. Cellulose tape may be used to hold the glasses to the frame. A pair of strong



FIGURE 69.—Stereogram.

reading glasses will serve as a spectacle stereoscope but will permit only a small separation of the pair of photographs with a corresponding reduction of the effective overlap area.



FIGURE 70.—Another view of a stereogram.

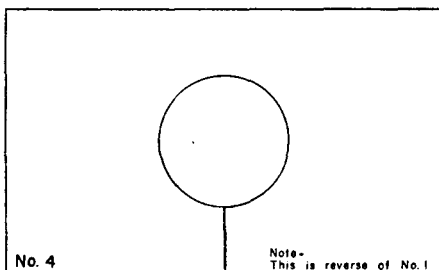
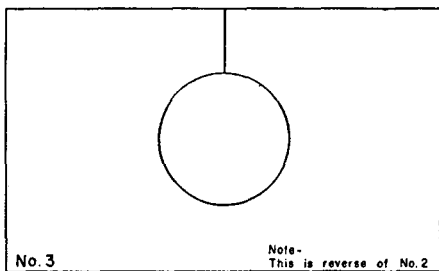
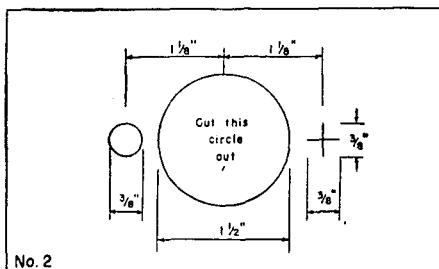
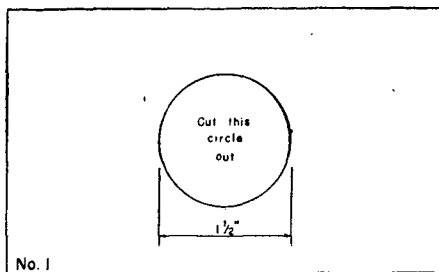

FIGURE 71.—Illustration of cards for use in stereovision exercises.

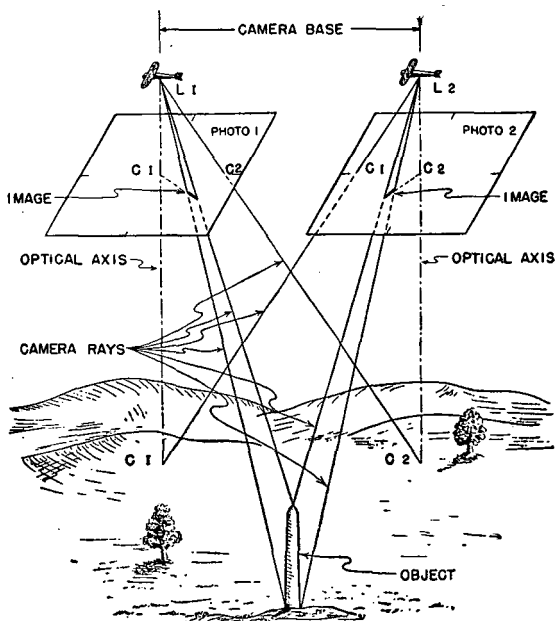

FIGURE 72.—Diagram of a stereo-pair of aerial photographs.

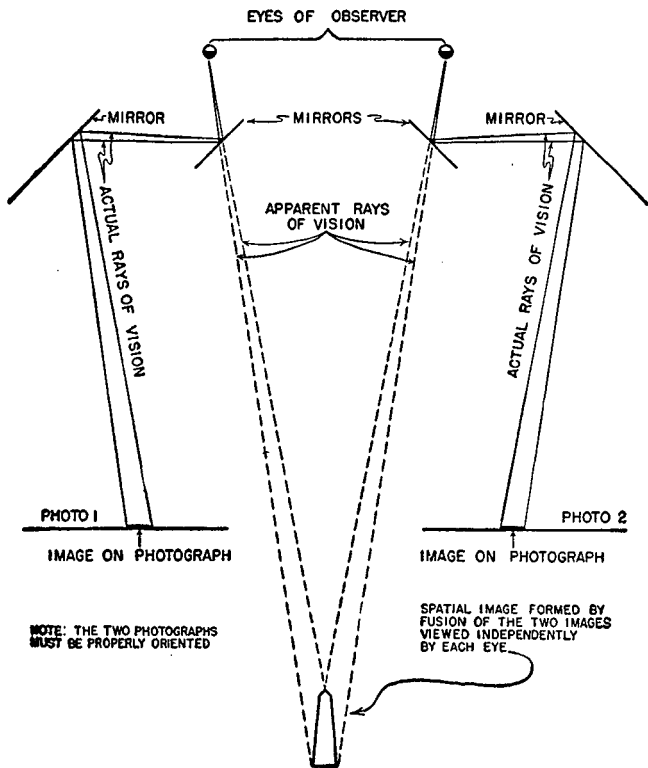

FIGURE 73.—Diagram showing stereo perception.

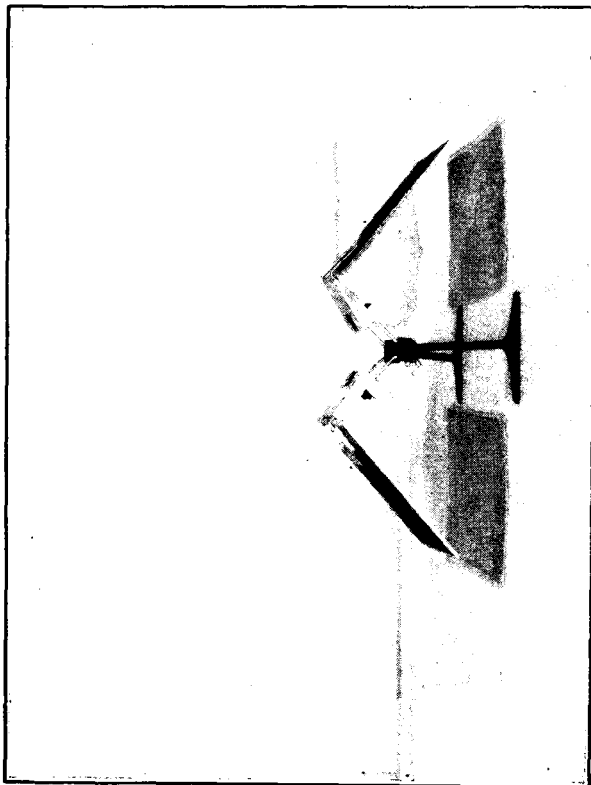

FIGURE 74.—Mirror stereoscope.

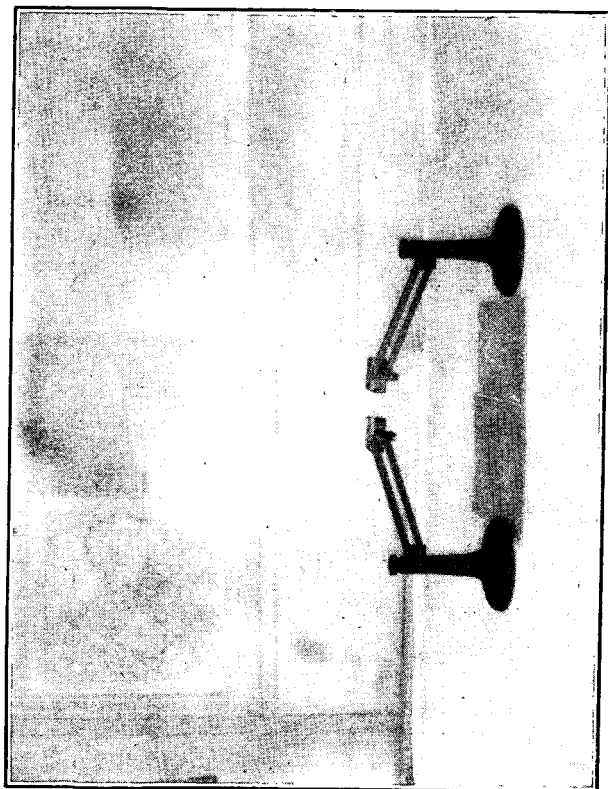

FIGURE 75.—Lens stereoscope.

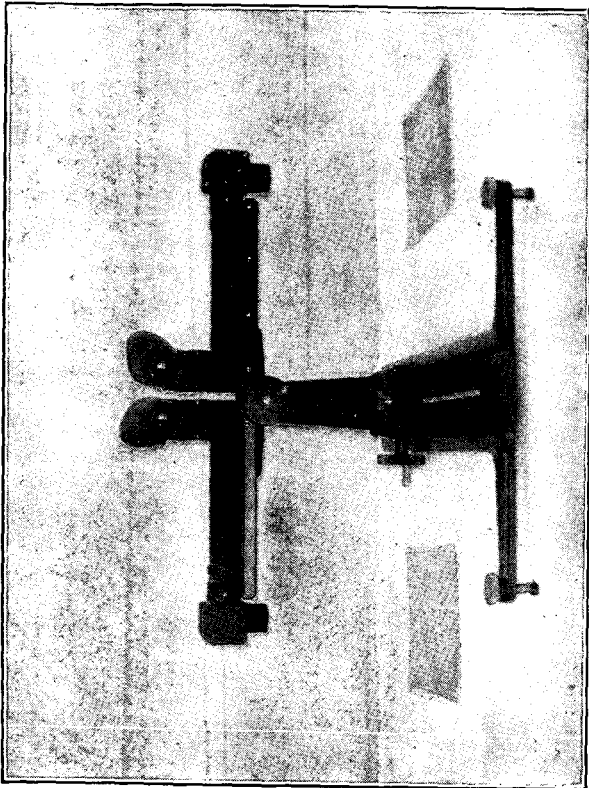

FIGURE 76.—Prism stereoscope.

■ 92. STEREO EXAMINATION OF AERIAL PHOTOGRAPH.—*a. General.*—(1) Appreciation of relative distances is based fundamentally on the slightly different view of various objects presented by each of the two eyes. A person with one eye or a person with only one eye open cannot perceive relative distance any more than a person can perceive depth looking at a single vertical photograph. Under such conditions, distance is sensed only through experience.

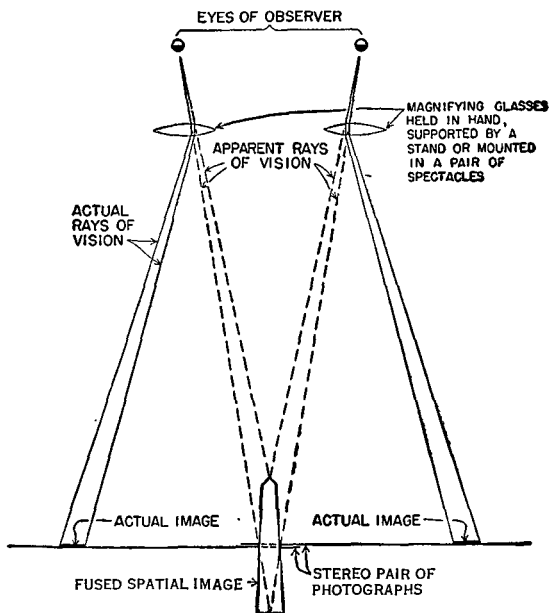

FIGURE 77.—Diagram showing stereo examination by means of improvised lens stereoscope.

(2) Unaided eyes viewing a distant object (fig. 78①) have their lines of vision almost parallel. As the object comes nearer (fig. 78②), the focal length of the eyelens decreases and depth perception is better. If each eye looks straight ahead with line of vision parallel, and the eyelenses are kept at a short focal length, the two images (fig. 78③) will fuse, the result being the same as in figure 78②. This latter

process usually requires training of the eyes, while with little training stereovision can be obtained with the use of spectacles (fig. 78④).

(3) If two vertical photographs of an object or a group of objects are taken to the same scale from two different camera positions as in figure 72, and each picture is viewed by one eye to the exclusion of the other but both pictures viewed simultaneously (fig. 73), the appreciation of distance is then possible because a different view is presented to each

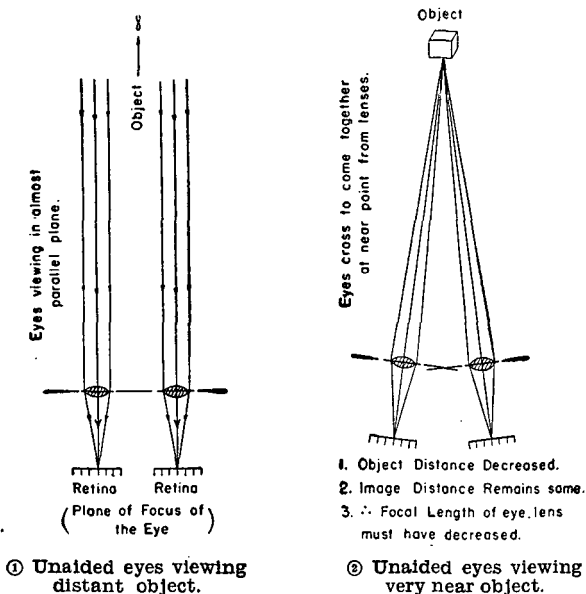
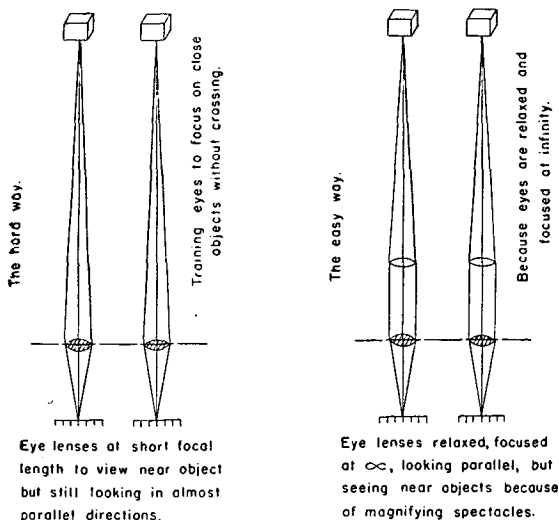

FIGURE 78.—Stereovision.

of the two eyes as is the case in ordinary vision. In order that a combined or "fused" image may be obtained, certain conditions must be satisfied in the arrangement and in the viewing of the two photographs. These are briefly as follows:

(a) Both eyes of the observer should be of equal power or corrected by optical aids, and the two photographs should be equally distinct and equally illuminated.

(b) The pictures should be so arranged with respect to each other and to the eyes of the observer that exposure conditions are restored. The distance between the centers of the two photographs corresponds to the base between camera positions, and the positions of the eyes correspond to the positions of the camera lens. The eyes must be parallel not only to the line joining the centers of the photo-



- ③ Stereoscopic viewing—training to see stereoscopically with unaided eye. ④ Stereoscopic viewing—training to see stereoscopically with spectacles which decrease focal length of eyelens.

FIGURE 78.—Stereovision—Continued.

graphs but also to a line on each photograph drawn between points of detail marking the two corresponding center points. The stereograms shown in figures 69 and 70 are the overlapping portions of two such vertical photographs. They have been mounted side by side in the proper relation with each other to secure stereovision. Any pair of overlapping vertical photos (taken at approximately the same elevation), if arranged in this same manner, can be read stereoscopically.

b. Method.—(1) Place one photo on top of the other so that overlapping detail common to both roughly coincides (fig. 79).

(2) Next note the position of an imaginary line joining their approximate centers. The eye base of the observer must be parallel to this line of centers. Turn the photographs as a unit until the condition is satisfied.

(3) Now separate the photos along the line joining the centers (fig. 80), moving the one on the right to the right and viewing it with the right eye, and the one on the left toward the left and viewing it with the left eye. The exact orientation of the photographs with respect to each other can be obtained by keeping detail, such as roads or streams, which appear in the overlap area parallel to each other. For example, take a road that appears on both photographs. Rotate one photo until the image of the road on this photo is parallel to its image on the other photo. The distance that two objects appearing in the overlap area have to be separated depends on whether the photos are to be examined by the naked eye or by some stereoscopic instrument. For beginners with the unaided eye, this separation of detail should be not more than $1\frac{3}{4}$ inches. With practice after the stereoscopic effect is obtained, the photographs can be gradually separated until a large portion of the overlapping area can be seen. If the study is made first with the right-hand photograph overlapped on top of the left and then with the left-hand photograph placed on top of the right, the entire overlapping area of a 9- by 9-inch stereo-pair with 60 percent overlap can be studied stereoscopically with the unaided eye.

c. Procedure of using stereoscope.—The following procedure should be observed when making a stereo examination of aerial photographs (see also sec. VII, TM 5-230):

(1) Orient the stereo-pair in the direction of flight so that the overlapping detail common to both is roughly in coincidence (fig. 79).

(2) Place the photographs under the stereoscope so that the left print (taken by the camera on the left of the overlap area) is observed by the left eye and the right print by the right eye.

(3) Shift the photographs so as to bring an imaginary line drawn between the center points parallel to the eye base and

in prolongation with one another in the center of the field of view of the stereoscope.

(4) Without changing the relative position of the imaginary lines drawn through the center points, bring together or separate the photographs until stereo conditions of fusion are best fulfilled (fig. 80).

■ 93. FAULTY STEREO EFFECTS.—*a. Faulty stereo orientation.*—

Faulty orientation of a stereo-pair with respect to the eye base introduces false parallax difference and lack of correspondence. These make it difficult to fuse detail and cause a diminution of relief.

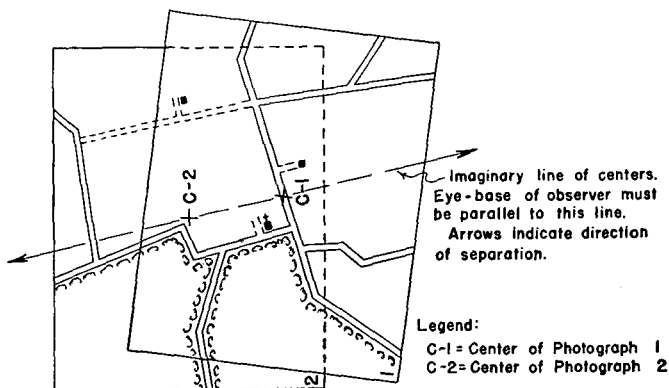

FIGURE 79.—First step in arranging photographs for stereo study (detail in overlap area matched).

b. Tilted photographs.—Photographs which are tilted cannot be brought into accurate correspondence as described in paragraph 92 and sometimes must be shifted as the field of view of the observer is moved from point to point. Distortion of relief results from such a condition.

c. Pseudoscopic effect.—If the position of two photographs forming a stereo-pair is reversed so that the left print (taken by the camera on the left side of the overlap) is viewed by the right eye and the right print by the left eye, the impression of relief is reversed; that is, the point of lowest elevation is reconstructed nearest to the eye and appears to be of high-

est elevation. Practical use may be made of this factor in that drainage lines may be traced by making them appear as ridge lines.

SECTION X

PREPARATION OF AERIAL PHOTOGRAPHS FOR USE AS MAP SUBSTITUTE

■ 94. GENERAL.—In order to make a photograph or groups of photographs sufficiently accurate and detailed for most efficient use, certain mechanical operations must be effected. Certain inaccuracies inherent in a single photograph may

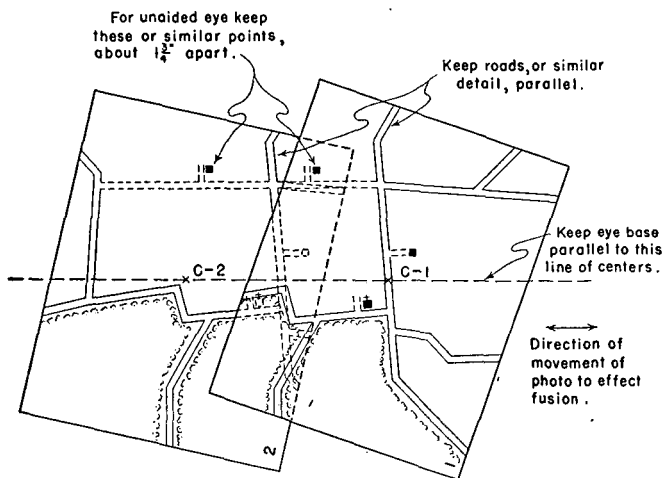

FIGURE 80.—Photographs arranged for stereo study.

be overcome in the compilation and finishing of a group, and with the aid of machines, stereo-pairs may be accurately contoured. By these processes the value of photographs as map substitutes or photomaps is greatly enhanced.

■ 95. SCALE.—An important difference between military maps and vertical photographs used as maps lies in the choice of scales. Military maps conform to a prescribed range of standard scales expressing the relation of ground to map in simple terms. The horizontal scale is uniform throughout the map. On the other hand, the scales of vertical photo-

graphs are dependent principally upon the variable and uncertain factors of lens height, camera tilt, and relief of the ground in the photographic field at the moment of exposure. The scale of a vertical photograph, therefore, not only changes on the several photographs of an overlapping series but is also not uniform on a single photograph. If the degree of scale variation is small the resulting errors become inappreciable, and probably no greater than those which result from average measurements made on a map in the field with the relatively crude instruments used in map reading.

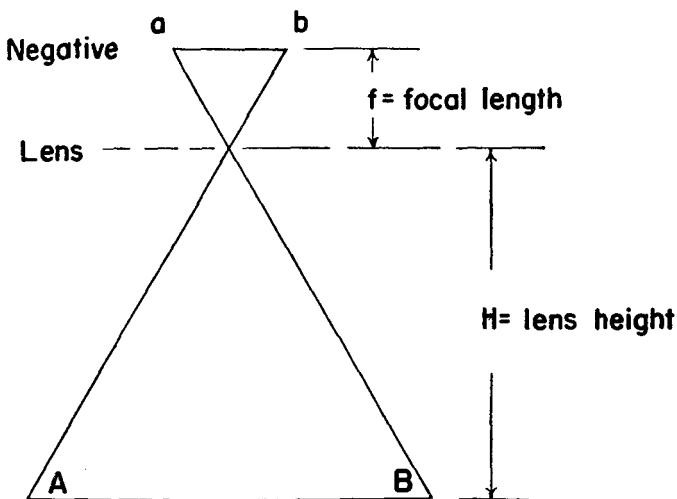

FIGURE 81.—Determination of scale from height.

■ 96. DETERMINATION OF SCALE.—*a. By lens height.*—By inspection of figure 81 it may be seen that, if the ground is assumed to be a plane surface, any distance on the negative, such as ab , bears a relation to the corresponding distance on the ground AB equal to f/H where f is the focal length of the camera and H is the height of the camera lens above the ground (both f and H being expressed in the same unit of measurement). Hence:

$$RF = \frac{f}{H}$$

Since the altimeter of the airplane usually expresses the elevation above sea level in place of H , the expression $H_a - E$ may be substituted, H_a being the altimeter elevation above

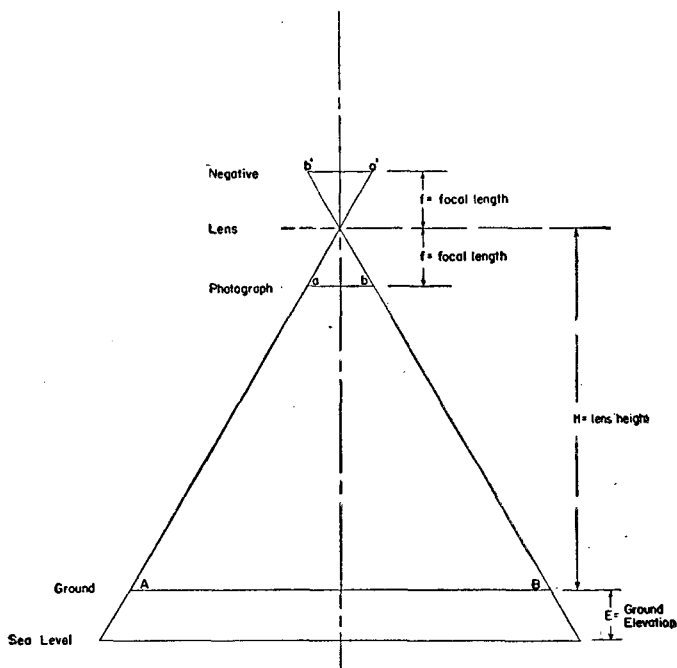

FIGURE 82.—Diagram showing relation of scale, focal length, and lens height.

sea level and E the average elevation of the terrain shown in the photograph (fig. 82). We may accordingly write

$$RF = \frac{f \text{ in feet}}{H_a \text{ in feet} - E \text{ in feet}}$$

Example:

Focal length of camera is 6 inches or $\frac{1}{2}$ feet.

Altitude of the airplane is 10,000 feet above sea level.

Elevation of the ground is 1,000 feet above sea level.

$$RF = \frac{\frac{1}{2}}{10,000 - 1,000} = \frac{1}{18,000}$$

It is usual for a request for aerial photographs to state the scale desired. The flying altitude of the airplane is determined from this formula.

b. By comparison with map or ground.—(1) In *a* above it was stated that the scale of an aerial photograph is equal to the quotient of the focal length of the camera divided by the height of the camera lens. The scale determined by this formula would be the true scale of the entire photograph under the conditions of absolutely accurate altimeter records, complete absence of tilt, and perfectly level terrain. However, altimeter records are often appreciably affected by local

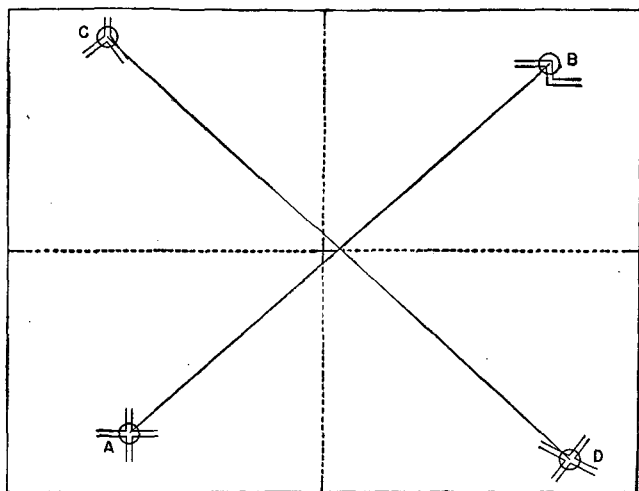

FIGURE 83.—Diagram showing proper location of scale lines.

atmospheric conditions, and the effects of tilt and relief will usually cause some scale variation within the limits of the photograph. For this reason, scale can be determined more accurately by comparing distances measured on the photograph with corresponding distances either on a map or on the ground. Such distances should be between points which are well defined both on the photograph and on the map (or ground). When it is desired to apply the scale to the entire photograph, the distances measured on the photo-

graph should represent the average scale of the photograph. In the discussion which follows, the selected distances are termed "scale lines."

(2) In order to represent the average scale of the photograph, a scale line should extend well across the face of the photograph (fig. 83). Since the effect of tilt is assumed to be radial along a line passing through the center of the photograph and because of its effect in compensating on opposite sides of the photograph, the scale line should pass near to its center. In order that the scale determination will not be affected unduly by relief, care should be taken that there is not a pronounced difference in relief between the points at the ends of the scale line. With the scale line thus determined, its RF can be solved in the same manner as given for maps in paragraph 14; the RF of the scale line being roughly the RF of the photograph.

(3) *Ground*.—The distance between the identified points is measured. Then:

$$\text{RF of the scale line} = \frac{\text{photo distance in inches}}{\text{ground distance in inches}}$$

Ordinarily it should prove convenient and satisfactory to select two points on a straight stretch of a highway and use the distance along the highway as the scale line in the computation of the RF of the photograph.

(4) *Map*.—(a) The most simple method of determining the RF of a scale line from a map of known RF is by converting the distance on the map to the equivalent distance on the ground and proceeding as in (3) above.

(b) A more rapid method of determining the RF of a scale line is by the direct formula:

$$\text{RF of scale line} = \frac{\text{photo distance in inches}}{\text{map distance in inches}} \times \text{RF of map}$$

(c) Although for terrain of low relief one such well-chosen scale line will often suffice, it is preferable that the average scale of the photograph be determined from two or more scale lines, the value assigned to the denominator of the RF of the photograph being the average of the denominators of the computed RF's of each scale line. Thus we may write

$$\text{Average RF of the photo} = \frac{1}{\text{mean of the denominators of the RF's of the scale lines}}$$

Example:

Distance *AB* on photo=8 inches
 Distance *AB* on map=6 inches
 Distance *CD* on photo=9 inches
 Distance *CD* on map=6.65 inches
 RF of map is 1:20,000

Using scale line *AB*

$$\text{RF} = \frac{8}{6 \times 20,000} = \frac{1}{15,000}$$

Using scale line *CD*

$$\text{RF} = \frac{9}{6.65 \times 20,000} = \frac{1}{14,778}$$

$$\text{Average RF of the photo} = \frac{1}{\frac{1}{2}(15,000 + 14,778)} = \frac{1}{14,889}$$

For ordinary purposes a 1:15,000 scale will serve in measuring distances on the photograph.

■ 97. SCOPE.—The area covered by an aerial photograph can be calculated readily by either of the following methods:

a. By the ratio $\frac{\text{ground distance}}{\text{photo distance}} = \frac{H}{f}$ (*H* and *f* being expressed in the same units of length)

Therefore the ground scope of any photograph = $w \frac{H}{f} \times l \frac{H}{f}$

where *w*=width of the photograph

l=length of the photograph

H=height of camera lens

f=focal length of camera

For K-3B type photographs (*f*=12 inches, *w*=7 inches, *l*=9 inches)

$$\text{Scope} = \frac{7}{12} \times \frac{12}{12} \times H \times \frac{9}{12} \times \frac{12}{12} \times H = \frac{7}{12} H \times \frac{9}{12} H \text{ square feet}$$

For T-3 type photographs (*f*=6 inches, *l*=*w*=32 inches)

$$\text{Scope} = \frac{32}{12} \times \frac{12H}{6} \times \frac{32}{12} \times \frac{12H}{6} = \frac{16}{3} H \times \frac{16}{3} H \text{ square feet}$$

Thus at a height of 12,000 feet the scope of these photographs is as follows:

For the K-3B type, scope = $\frac{7}{12} 12,000 \times \frac{9}{12} 12,000 = 7,000 \times 9,000$
 square feet = 2.26 square miles.

For the T-3A type, scope=64,000×64,000 square feet=146.9 square miles (overall).

b. By the ratio, $RF = \frac{\text{photo distance}}{\text{ground distance}}$

Therefore scope= $\frac{w}{RF} \times \frac{l}{RF}$

where w =width of the photograph

l =length of the photograph

Example:

For a K-3B photograph having an RF of $\frac{1}{12,000}$

$$\text{Scope} = \frac{7(12,000)}{12} \times \frac{9(12,000)}{12}$$

$$= 7,000 \times 9,000 \text{ square feet} = 2.26 \text{ square miles}$$

■ 98. GRAPHIC SCALE.—The preparation of a photograph for use as a map may include the construction of a graphic scale in yards or other appropriate units. When given, or having determined, the RF of the photograph, the graphic scale is constructed by the methods employed in constructing such scales for maps or sketches (see sec. II). On mounted photographs the scale so constructed should be placed on the lower margin of the mount, and if desired may extend entirely across the mount. On unmounted photographs, it should usually be placed on the back of the print in order not to obscure unnecessarily the detail on the face of the print. See paragraph 105 for the atlas grid.

■ 99. TO TRANSFER DETAIL OR CHANGE SCALE.—*a. By photography.*—Photographs may be enlarged or reduced by rephotographing when the necessary facilities are available. The resulting prints are usually not as good as the originals, and enlargements lose definition of detail.

b. By rectangular grid (fig. 84).—For average military purposes the detail of a vertical photograph may be roughly enlarged, reduced, or transferred by means of a special rectangular grid on the photograph. To transfer by this method at a changed scale proceed as follows:

(1) Fit a transparent overlay to the photograph and lay out on it a rectangular grid to a scale which is some fractional part of 1.8 inches (atlas grid, par. 105).

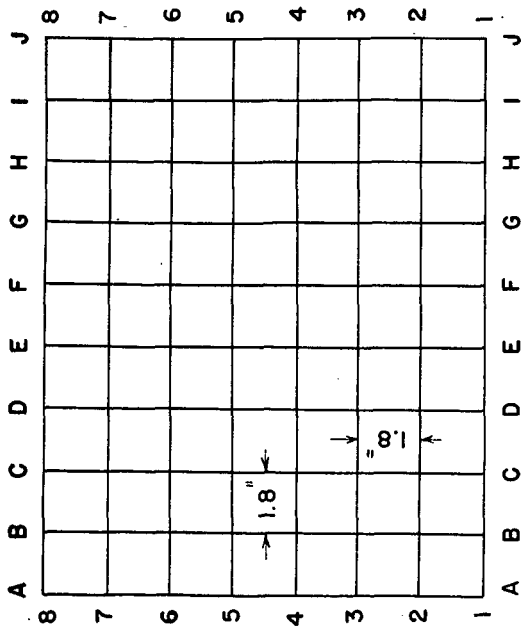

ENLARGEMENT
Scale 1:10,000

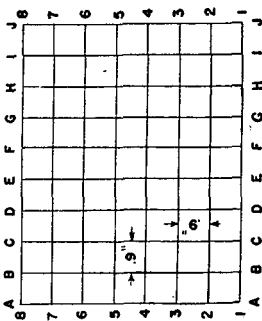

PHOTO
Scale 1:20,000

FIGURE 84.—Change of scale by rectangular grid method.

(2) Trace through on the overlay the topographical detail which it is desired to transfer.

(3) Lay out the atlas grid on a suitable sheet of paper at the new selected scale.

(4) Copy from the photograph overlay to the changed scale overlay (or map), square by square, the detail appearing therein in its proper relation to the square.

(5) For more accurate detail, construct a grid card for each scale. With these cards, important features may be much more accurately located.

Caution. It is to be understood that the above methods for changing scale merely result in copying or reproducing the detail as it appears on the photograph and in no sense should be considered as methods of rectification or elimination of inherent errors.

■ 100. DISTANCE.—Having determined the RF of a vertical photograph intended for use as a map and having constructed a graphical scale of yards for use on it, the photograph reader is ready to scale distances as required. The methods used in the measurement of horizontal distances on maps explained in section II or some elementary text, are also applicable to vertical photographs used as maps. It should suffice to state that the paper strip and graphic scale method is probably the most universal and satisfactory general method. The engineer's scale and the map measurer each serve in their respective fields of usefulness.

■ 101. DIRECTION.—*a.* It has been stated that in a vertical photograph which is of average rolling or fairly flat terrain and which has a small angle of tilt, the combined effect of errors over the center half of the photograph is entirely negligible for ordinary use as a map and is rarely prohibitive even in the marginal areas. Therefore, for normal military uses, direction angles and azimuths on a photograph have the same significance as they do on maps, and may be measured and laid out with the protractor exactly as is done with maps. The methods of measuring angles and directions on maps in section III apply.

b. In order to lay out or measure directions on a photograph with the facility with which this can be done on a map, it is obviously necessary to equip the photograph with

the magnetic north, true north, or grid north line. When practicable and desirable, all three of these are shown. Magnetic north, however, is the most suitable base direction for

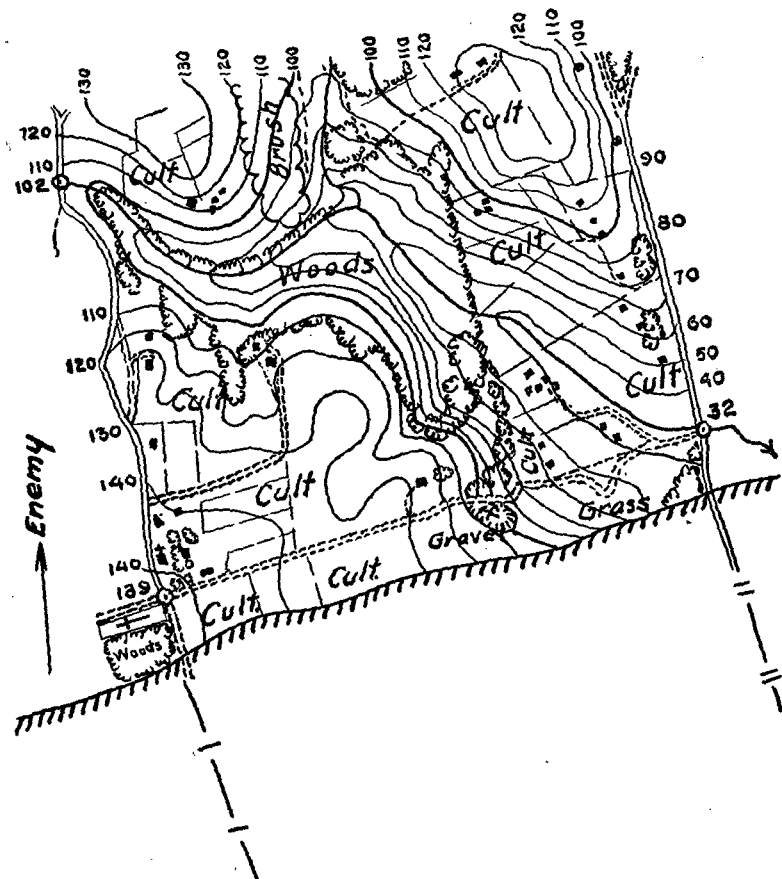

FIGURE 85.—Overlay of section of contoured aerial photograph.

photographs intended as substitutes for military maps and is the most available base direction for photographs of unmapped country. The magnetic north line may be traced

on the photograph negative with a stylus to print in black lines for reproduction in quantity.

■ 102. ELEVATION.—The determination of elevations by the use of a formula such as was developed in paragraph 73b is theoretically possible. The accuracy of results secured from the use of such a formula is dependent upon the accuracy of measurements on the face of the photographs, the reliability of corresponding map and ground positions, the determination of the lens height and elevation of the ground plumb point, and the assumption that the effect of tilt is negligible. Possible error introduced from these sources cannot be discounted in the evaluation of the character of the results. The most practical method of determining elevations is by trigonometric leveling. In order that elevations may be determined accurately direct from aerial photographs, photogrammetric equipment must be employed.

■ 103. CONTOURS.—*a.* In unusual situations it may be desired to contour a photograph in the field. This may be done by copying contours onto the photograph from an existing contoured map of the area, or by interpolating logical contours from selected spot elevations determined on the ground. Contouring should be done with the aid of a stereoscope.

b. To contour accurately an aerial photograph it is necessary to have numerous ground control points, and the drawing of the contour lines must be done with the aid of a stereo-comparagraph or some similar instrument. When these and other photogrammetric instruments are used, contouring is done by trained personnel. Engineer topographic organizations prepare accurate large-scale topographic maps, solely from photographs taken on planned flights over large areas upon which ground control has been established.

c. Ridge and streamlining may be accomplished in the field on a photograph or stereo-pair, as an aid to interpretation of relief. After this has been done, contouring may be accomplished as described in *a* above and then placed on an overlay (fig. 85).

■ 104. LOCATION OF MAGNETIC NORTH ON PHOTOGRAPH.—*a.* *When map showing magnetic north is available (fig. 86).—*Select two points identifiable both on the photograph and on the map and so located that the line joining them passes

through or near the center of the photograph. The direction of such a line will be little if at all affected by relief and tilt. By means of a protractor, determine from the map the magnetic azimuth of the line joining the points selected. From the corresponding line on the photograph, shown in figure 86 as *AB*, turn off counterclockwise an angle equal to the magnetic azimuth measured on the map to *AM*. This establishes on the photograph the magnetic base corresponding to that shown on the map.

b. *By means of compass.*—Orient the photograph by corresponding points on the photograph and on the ground.

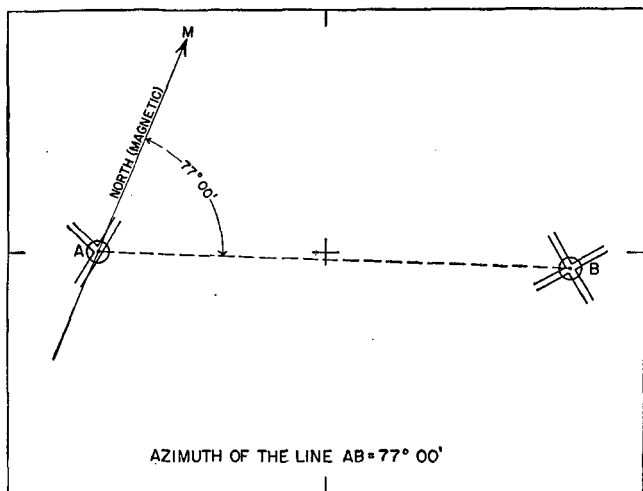

FIGURE 86.—Diagram showing method of locating magnetic north line on photograph.

Place a compass on the photograph and draw a line on the photograph parallel to the direction of magnetic north indicated by the compass needle.

■ 105. **ATLAS GRID** (fig. 87).—*a.* Because of variation in scale, other inaccuracies, and the difficulty of locating grid lines, the military grid is not used on single photographs or uncontrolled mosaics. Instead of the military grid, the atlas grid is used. The grid lines of the atlas grid are always 1.8 inches

apart regardless of the scale. With this interval, on a 1: 20,000 photo, the grid lines are about 1,000 yards apart. The lines are numbered from the bottom up and lettered from left to right. Thus the origin of the coordinates is at the lower left corner of the photo; numbers 1, 2, etc., upward; letters *A*, *B*, etc., to the right; the coordinates of the origin being (*A.0—1.0*).

b. To superimpose atlas grid on photograph.—In the process of reproduction, the edges of a photograph may vary

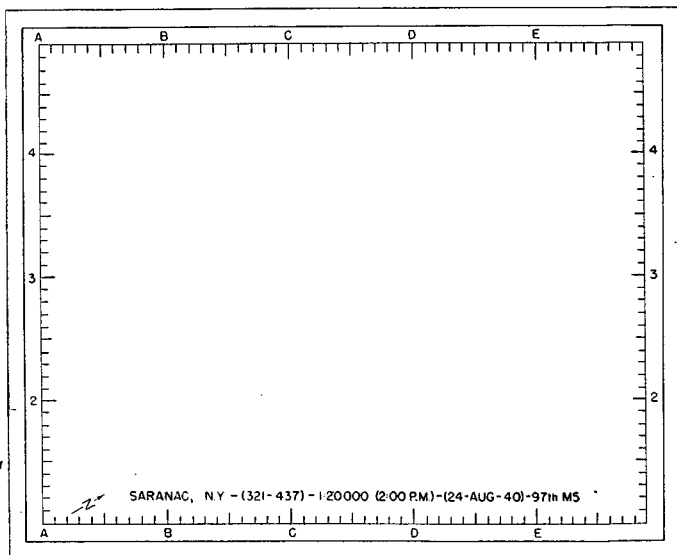

FIGURE 87.—Atlas grid and marginal data.

and successive prints may differ. In order to provide an accurate origin from which to measure, collimation marks are registered at the center of the four sides of a vertical photograph (par. 62b(1)(b)). To superimpose an accurate atlas grid on a photograph, the true edges must be established from the collimation marks, and the grid lines then spaced 1.8 inches apart beginning at the intersection of the true edges at the lower left corner of the photograph. Thus on a 9- by 9-inch print the true edges would be 4½ inches from

a line drawn between the opposite collimation marks, and the 1.8-inch grid would be laid off along these true edges. Figure 87 represents a 7- by 9-inch photograph which is not quite full size. If the photo were exactly 9 inches wide the *F*-coordinate line would exist. It must be borne in mind that the atlas grid has no definite limits as to the total area covered by it.

■ 106. MILITARY GRID.—*a. General.*—While the military grid is not used on single photographs or uncontrolled mosaics, it is highly desirable on controlled mosaics and photomaps made from them. Because of the inherent characteristics of mosaics, the military grid when superimposed upon them is only approximate. If a gridded map of the photographed area is available, the military grid may be transferred without difficulty to the mosaic by proceeding as follows:

(1) Three points, *A*, *B*, and *C* are selected on the photograph (fig. 86) which can be readily identified on the map. For greatest accuracy, the points selected should be well-spaced around the central area of the photograph.

(2) Determine the average scale of the photograph by the comparison of map and photograph distances as explained in paragraph 95. In this case the average scale is assumed to be

1 inch = 434 yards or

$$RF = \frac{1}{15,624}$$

(3) Determine the grid coordinates of *A*, *B*, and *C* from the map. These are as follows:

A = (1359.35–1789.52)

B = (1361.35–1790.16)

C = (1360.88–1788.00)

(4) To determine the position of the 1790 *X* (or east-west) grid line, determine the distance from the two points nearest that grid line.

In this case the distance from *A* to the 1790 grid line is 1,790,000–1,789,520=480 yards (measured north), and the distance from *B* to the 1790 grid line is 1,790,160–1,790,000=160 yards (measured south).

Draw arcs from points *A* and *B*, respectively, as shown with these distances as radii.



FIGURE 88.—Method of superimposing military grid on aerial photograph or mosaic.

(5) To determine the position of the 1361 north-south grid line, determine its distance from two points, in this case *B* and *C*. The distance from *B* to the 1361 grid line is 635 yards measured west, and the distance from *C* to the 1361 grid line is 120 yards measured east.

Draw arcs from points *B* and *C*, respectively, as shown with these distances as radii.

(6) Draw the remaining grid lines parallel to the two already obtained at a distance corresponding to 1,000 yards on the photograph, or

$$\frac{1,000}{434} = 2.3 \text{ inches}$$

(7) Number the grid lines properly and indicate the direction of magnetic north. Before inking, compare the photograph grid critically for any discrepancies which clearly cannot be attributed to relief or tilt displacements.

(8) Although three points, such as *A*, *B*, *C*, are preferable, two points, as *A* and *B*, would suffice for transferring the grid. In this case the procedure for establishing the grid base line is the same, but the 61 north-south grid line is established by drawing line 61 tangent to its arc about *B* (635 yards) and intersecting line 90 at right angles.

(9) The grid may be superimposed roughly by drawing the lines on the photograph through images which correspond to objects or features through which the grid lines on the map pass.

b. Reproduction.—To reproduce a gridded mosaic, in quantity, either draw the grid on the mosaic in black ink and then photograph it or else fit the film negative to the back of the photograph over an illuminated glass plate, carefully register it, cut the grid through the film coating with a stylus, and print from the original negative.

■ 107. ORIENTATION.—*a.* In the field, the photograph, when equipped with a graphic scale and magnetic north point, may be oriented according to the several methods prescribed for maps. All images on the oriented photograph are correct as to direction from a point near the center of the photograph, but serious discrepancies may exist in the outer portion of the photograph where great difference in relief exists. Therefore, use of the outer areas of the photograph should be

avoided where possible and resort made to an overlapping photograph which shows the area under consideration nearer to its center.

b. A rough means of determining north on certain photographs, which is not possible on maps, is by the use of shadows. At noon, in the Northern Hemisphere and out of the Tropics, the shadows will appear on the north side of the objects. The accuracy depends upon the proximity of the noon hour when the photograph was taken and the length of the shadow. For more details on the path of the sun, see paragraph 25.

■ 108. RESTITUTION.—It should be realized at this stage that vertical aerial photographs cannot be accurate maps in fact unless a variety of impossible or impracticable conditions is satisfied. These conditions would include perfectly level terrain, a perfectly level stationary camera platform, a mechanically perfect camera, and a perfect camera lens, film, print paper, and weather. It has been shown that good vertical photographs of terrain of small relief approximate the characteristics of a map. However, it is desirable that the photograph reader be able to use, either in conjunction with maps or as substitutes for maps, photographs which contain tilt or obliquity and relief. He should be able to plot the map positions of images recorded on such photographs and know how to transform the detail from the oblique to the horizontal when desired for correcting or posting existing maps. Restitution is the process of determining the true positions of objects the images of which appear distorted or displaced on aerial photographs. Some useful methods of restitution are described in the following paragraphs. Each method has its limitations. Some of those described do not correct displacements due to relief and serve only to rectify the photograph. More complete details using actual photographs are given in paragraphs 97 and 98, TM 5-230.

■ 109. RECTIFICATION OF AREAS BY GRID METHOD.—*a. Purpose.*—The grid method of enlarging, reducing, or reproducing an aerial photograph or map is described in paragraph 99. Homologous grids also may be employed as a rough expedient to rectify slightly tilted photographs. This method is not applicable to oblique photographs nor will it eliminate the effect of displacements of position caused by relief.

b. Procedure.—In order to rectify a photograph, select four well-distributed points, such as *A*, *A'*, *I*, and *I'* in figure 89①, about the margin of the photograph which can be identified on a map. Crossroads, road junctions, important buildings, bridges, or other well-defined locations are suitable. Join the four points on both the photograph and the map by straight lines to form a four-sided homologous figure on each. Divide the opposite sides of the two figures into the same number of equal parts from $\frac{1}{2}$ to 1 inch in length. Joining the divisions laid off, draw on both the photograph and on the map, grids which serve to subdivide the respective areas into the same number of small homologous figures. Finally copy in homologous relation the detail appearing in each grid subdivision of the photograph in the corresponding subdivision of the map.

■ 110. RECTIFICATION OF AREAS BY TRIANGULAR DIVISION METHOD.—*a. Purpose.*—This method may be used to rectify either a tilted or an oblique photograph. It is based upon the theory that straight lines on the map appear as straight lines on the photograph. It will not eliminate the effect of displacements of position caused by relief.

b. Procedure.—(1) *When only four control points are available.*—Select four points, such as *A*, *B*, *C*, and *D* in figure 90, on the photograph which can be identified on the map and so distributed as to include the area under consideration. Join these points with straight lines to form a four-sided figure such that the opposite sides, when extended, will meet in points *F* and *G* at a convenient distance. If these points fall off the photograph, either they must be extended onto another piece of paper or an overlay of a large sheet of tracing paper must be used. Draw the diagonals *AC* and *BD*. Through their intersection *O* draw lines *FH* and *GI* from *F* and *G*, respectively. It may be observed that in addition to the four control points originally selected, there are now five more points on the photograph, *F*, *G*, *H*, *I*, and *O*, the map positions of which are fixed. The figure *ABCD* has been subdivided into four smaller four-sided figures. Draw diagonals in each of these and continue the process until the “controlled” subdivision of the area results in triangles of suitable size, usually of about $\frac{1}{2}$ -inch sides. Using the corresponding points *a*, *b*, *c*, and *d* on the map or on an overlay traced

from the map, proceed similarly to produce the same number of homologous triangles. Finally, copy in the triangles of the map figure the corresponding detail as it appears in homologous relation in the corresponding triangles of the photograph figure.

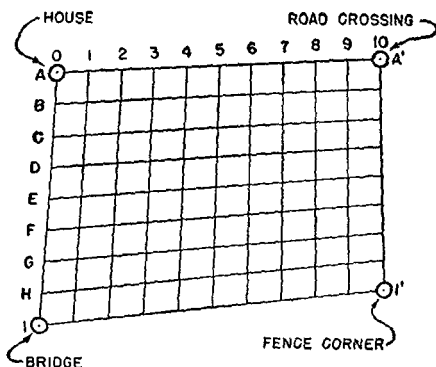

① PHOTOGRAPH

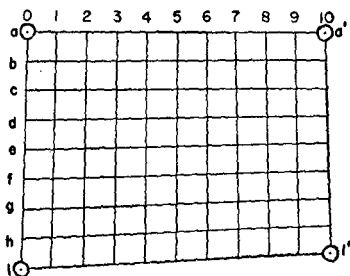

② MAP

FIGURE 89.—Grid method of restitution.

(2) *When more than four points of control are available.*—When more than four points of control are available the method is simpler and can be done in less space. On an overlay, trace from the map a large number of well-distributed control points, such as *a, b, c, d, e*, etc., in figure 91, which can

be identified readily on the photograph. Proceed to join by lines, these points as they appear on the map and the photograph, respectively, producing homologous figures. Using diagonals as necessary, carry the subdivisions further to pro-

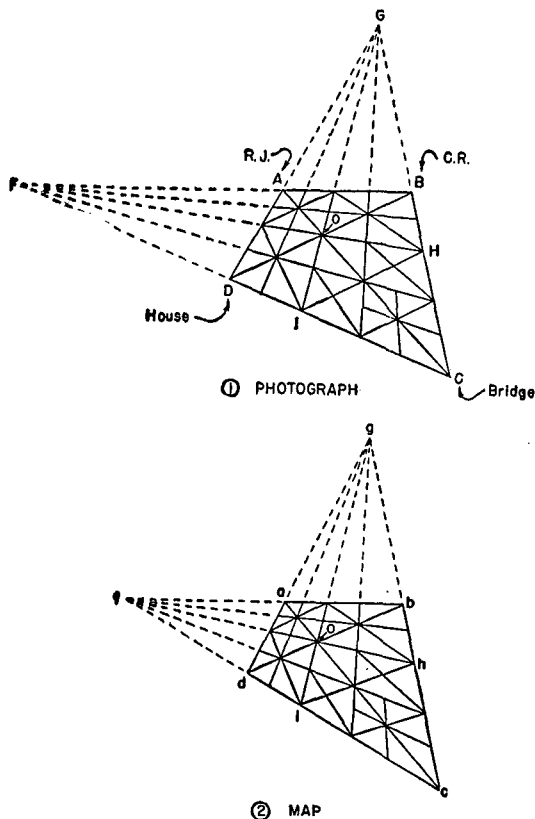
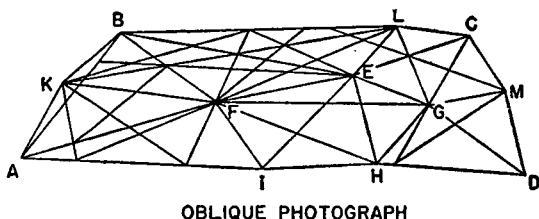

FIGURE 90.—Triangular division method of restitution with four control points.

duce triangles small enough for the desired accuracy without causing undue congestion. Proceed to copy the detail from the photograph triangles to the corresponding map triangles.

Figure 91 illustrates the mechanics of the method in its application to the rectification of an oblique photograph.

■ 111. LOCATION OF POINT BY TRACING PAPER METHOD OF RESECTION.—*a. Purpose.*—The method of resection by means of a piece of tracing paper may be used to plot roughly the map position of a limited number of points appearing on a vertical photograph.



OBLIQUE PHOTOGRAPH
To avoid congestion subdivisions not carried to smallest possible.

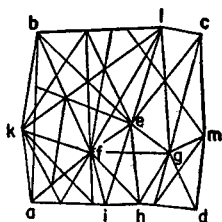

MAP

FIGURE 91.—Triangular division method of restitution where more than four control points are available.

b. Procedure (fig. 92).—Identify on the photo at least three points (preferably five) that appear on the map. Mark on a sheet of tracing paper the position of these points and of the point to be located on the map. This is done most readily by tacking the photograph over the tracing paper and with a pin pricking through each point. On the tracing paper,

draw rays from the point *P*, the location of which is desired, to each of the known points. Place the tracing paper on the map so that the ray to each of the known points passes through the map location of the corresponding point. The point, the location of which is desired, is then in its relative position to the known points. Its position may be pricked onto the map.

c. Limitations.—This method cannot be properly termed restitution because errors of tilt and relief in the photograph are in no way corrected unless the point, the location of which is desired, chances to fall, in their respective cases, either on the isocenter or the plumb point of the photograph. However, the error of location can sometimes be reduced by selecting more than the minimum of three known points. Thus five known points may be selected and it may not be possible to cause all five rays to pass through the respective map positions at one time. If four rays can be made to do so, the other ray may be deemed in error and disregarded.

■ 112. LOCATION OF POINT BY PAPER STRIP METHOD.—*a. Purpose.*—This method may be used to determine the map location of a few points on an aerial photograph. It may be employed with both tilted and oblique photographs. It will not eliminate the effect of displacements of position caused by relief. It is especially useful in bringing maps up to date by locating on the maps features which did not exist at the time that the area was surveyed. It is not necessary that the map and photograph be of the same scale.

b. Procedure (fig. 93).—Assume that it is desired to determine the map location of the cross road at *Y* and the house at *X*, respectively, on an aerial photograph.

(1) Select as control, four points readily identifiable on both the photograph and the map (*A*, *B*, *C*, *D*) and join them by lines as shown. In general the points, the locations of which are desired, should be within or near this quadrilateral.

(2) Draw the diagonals *AC* and *BD*.

(3) From any two of the four control points on the photographs, as *A* and *C*, draw rays through the points *X* and *Y*. Select the ray centers to give good intersections at the desired points.

(4) Place a paper strip as in figure 93① and mark on the paper strip e , f , and g (points where the lines of the figure cross the strip) and x and y where the rays to X and Y , respectively, cross it.

(5) Place the paper strip as in figure 93② so that e , f , and g fall on their respective lines from A , and mark on the map the points x and y as determined by the marks on the paper strip.

(6) Draw rays on the map from A through X and Y .

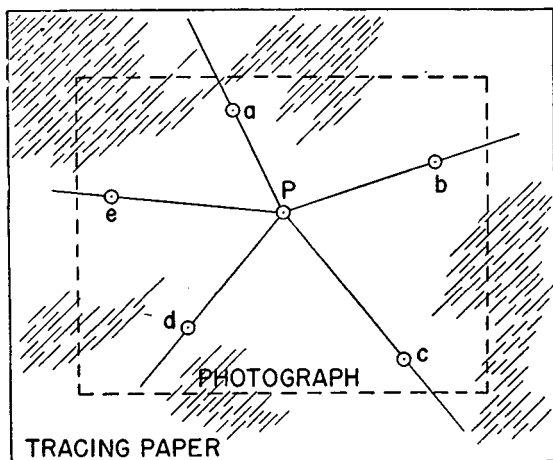

①

FIGURE 92.—Location of point on map by tracing paper method of resection.

(7) Similarly place another strip on the reverse side of the paper over the photograph as in figure 93③, marking the position of the five rays from C .

(8) Place this second strip on the map as in figure 93④, mark on the map the points x' and y' , and draw the rays Cx' and Cy' . The intersections X' and Y' give the locations on the map of the points X and Y on the photograph.

■ 113. LOCATION OF POINT BY RADIAL LINE METHOD.—*a. Purpose.*—It will be recalled that in paragraph 75 it was stated that for practical purposes the combined effect of relief

and tilt in slightly tilted photographs is assumed to cause displacements along a radial line passing through the principal point (center) of the photograph. Use is made of this assumption to provide a method for determining accurately the map position of a point appearing in the overlap of two

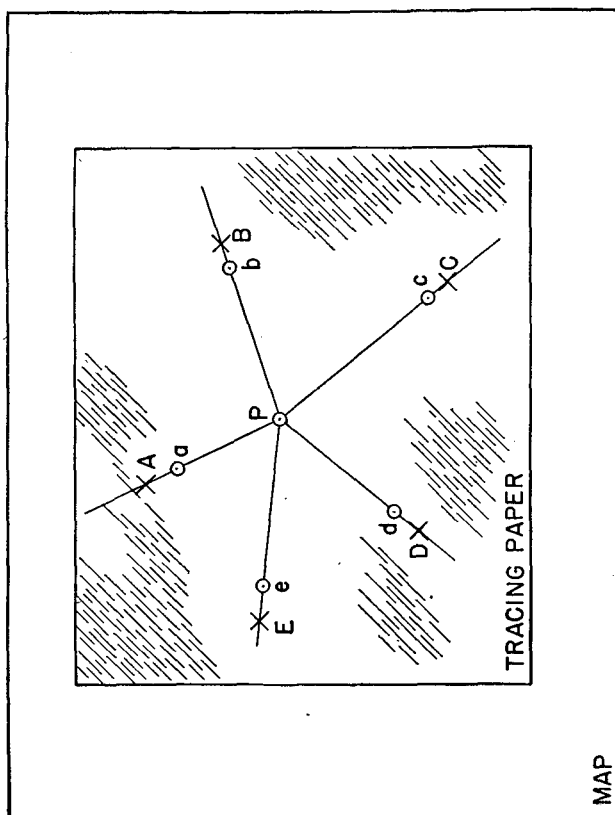

②
Figure 92.—Location of point on map by tracing paper method of resection—Continued.

aerial photographs taken at different camera positions. This method of restitution is the only one which will correct for both relief and tilt. When the tilt is small (3° or less) the assumption that displacements are radial along a line pass-

ing through the principal point is within the bounds of plotting accuracy. The method fails, however, in the presence of excessive tilt and cannot be used with oblique photographs. It is not necessary that the two photographs used are of the same scale. However, if the point sought falls on

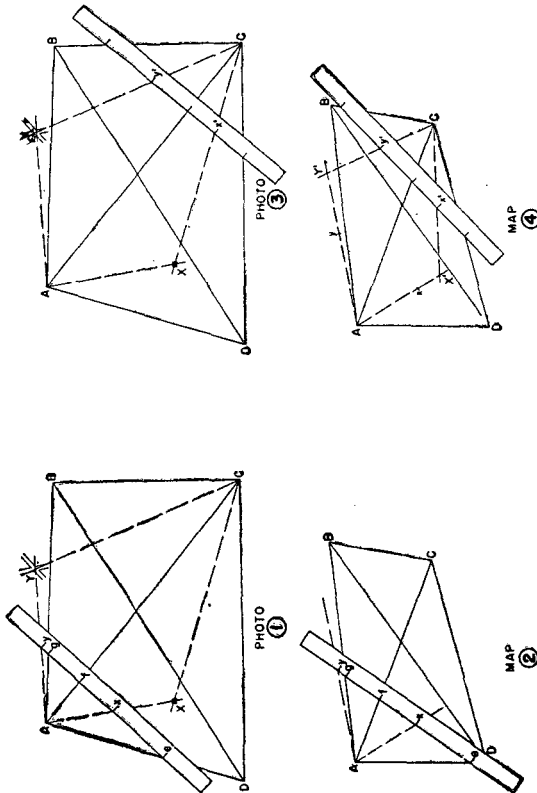

FIGURE 93.—Paper strip method of restitution.

or near the line joining the centers of the two photographs, the method fails because of the lack of a good angle of intersection.

b. Procedure (fig. 94).—Let it be assumed that it is desired to locate on a map an object *A* which appears on two overlapping vertical photographs. Proceed as follows:

(1) Identify on the map and on each of the two photographs, three points which will serve to orient the photograph with respect to the map. A different set of points may be selected for each photograph or the same identical points, as X , Y , and Z shown in figure 94①. The points selected should be well out from the center of each photograph and so distributed that the rays drawn from them to the center of each photograph provide good three-point resection. Points grouped too closely cause acute intersection angles between the rays drawn to the center of the photograph and make accurate work difficult.

(2) Inclose the three points selected on the photograph and the map in small triangles. Inclose the object A to be located on the map in a small circle on each photograph.

(3) Place a piece of vellum over the map and mark on the vellum the map positions of the points X , Y , and Z (fig. 94①).

(4) Locate on each photograph (marked Nos. 1 and 2) the principal point (center) and mark this with a cross C_1 and C_2 , respectively. Draw rays from the photograph positions of X , marked X_1 and X_2 , respectively, Y , Z , and A to C_1 and C_2 , respectively (fig. 94② and ③).

(5) Place the vellum over photograph No. 1 and orient it so that the points X , Y , and Z marked on the vellum will fall on the rays drawn on the photograph through the images of those points (X_1 , Y_1 , and Z_1). Trace on the vellum the ray drawn through the object A_1 (fig. 94④).

NOTE.—In doing this we have in effect located on the vellum by resection the position of C_1 and the direction of the position of A with respect to C_1 . Any displacement of A_1 due to relief or tilt is radial along this line.

(6) Next place the vellum over photograph No. 2 and orient it so that the points X , Y , and Z marked on the vellum again will fall on the rays drawn on the photograph through the images of those points X_2 , Y_2 , and Z_2 . Trace on the vellum the ray drawn through the object A_2 (fig. 94⑤).

(7) The intersection of the two rays through the objects A_1 and A_2 , respectively, as traced on the vellum, plots the position of A to the scale of the map. The vellum may again be placed over the map and oriented so that the positions of points X , Y , and Z on the vellum and on the map are superimposed one above the other (fig. 94⑥). The position of A may then be pricked onto the map.

■ 114. RECTIFICATION BY PHOTOGRAPHY (fig. 95).—By means of the Air Corps transforming printer, tilted and oblique photographs may be projected through the required angle so as to bring the photograph into a horizontal or any desired plane.

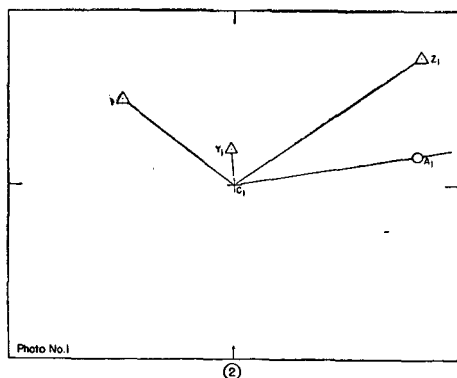
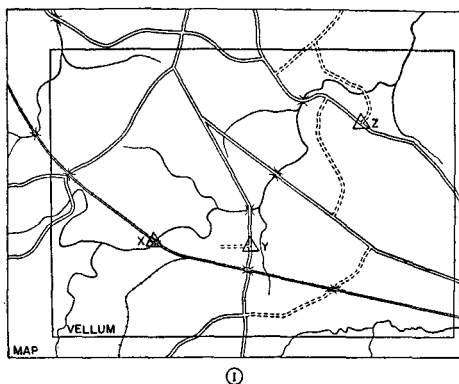

FIGURE 94.—Radial line method of restitution.

This process of rectification of the photograph does not correct for the effects of relief. As previously stated, during the transformation, images lose definition to a varying degree depending upon the amount of enlarging.

SECTION XI
PHOTOMAPS

■ 115. GENERAL.—A photomap is a single photograph, composite, or mosaic which has been prepared by the addition of grid, marginal and place-name data, and produced in quan-

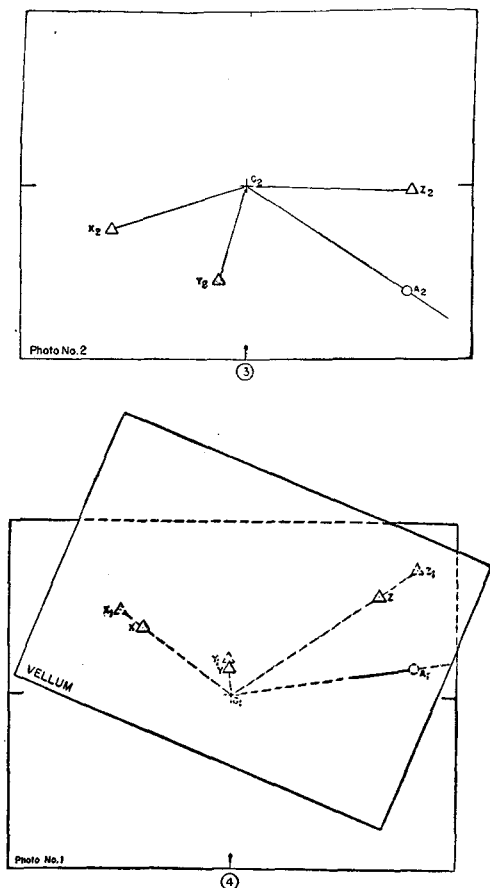

FIGURE 94.—Radial line method of restitution—Continued.

tity by contact printing or lithography. When time for preparation and available information permit, these data will be in the same form and as complete as for standard maps.

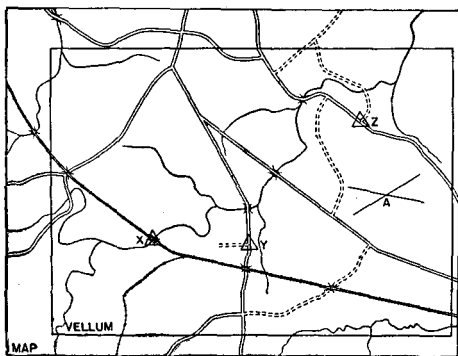
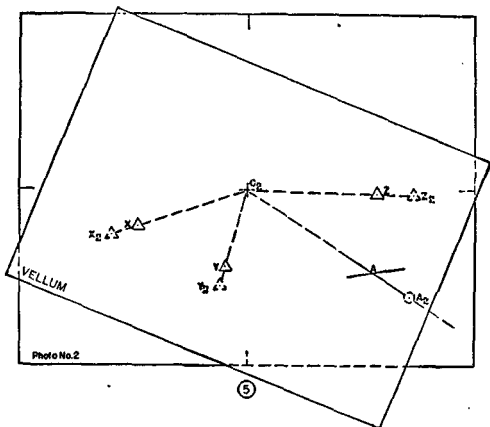

FIGURE 94.—Radial line method of restitution—Continued.

Since the photomap, however, finds its greatest use in providing information quickly, quite frequently much of the data usually found on a map will be missing.

■ 116. TYPES OF PHOTOMAPS.—The types of photomaps most frequently encountered are as follows:

a. *Reproduced single lens photographs*.—These photographs may be either verticals or obliques (fig. 96) and may be prepared by lithography or by contact printing, at the same scale as taken or by enlargement or reduction. Because of the wide area coverage, the T-5 (wide angle) photograph, print size 9 by 9 inches, provides an excellent source for the preparation of a hasty photomap. Normally the photograph will be taken at 20,000 feet above ground level (scale 1/40,000) and will be enlarged to 1/20,000.

b. *Reproduced composites* (fig. 97).—The tandem T-3A composite, utilized extensively for mapping photography, is

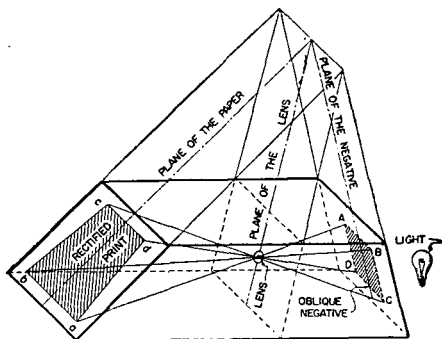

FIGURE 95.—Diagram of transforming printer.

frequently converted to a photomap by enlargement and reproduction of the center or "heart." As a rule, a square section of the center of the composite, measuring about 9 by 9 inches, is used.

c. *Reproduced mosaics* (fig. 98).—The usual form of photomap is prepared by reproduction of a controlled or uncontrolled mosaic, constructed as indicated in paragraph 65. This type of photomap may be made up in as many sheets as required to cover a given area, providing continuity between adjacent sheets in the same manner as a series of map sheets.

■ 117. MARGINAL DATA.—Marginal data for the reproduced individual photograph will be that given in paragraph 77.

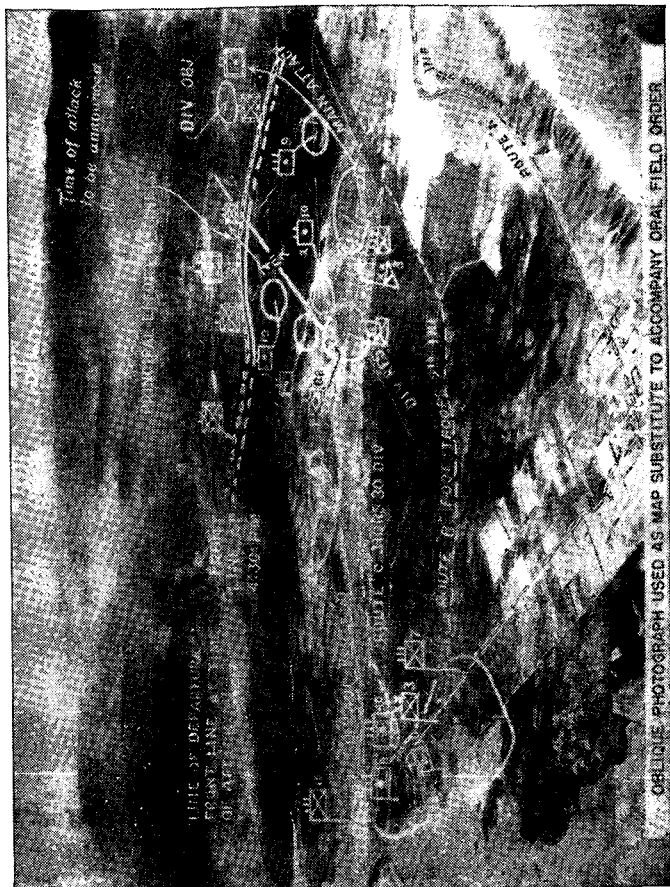

FIGURE 96.—Single oblique used as photomap.

Photomaps which are made from mosaics and certain wide coverage photographs may have, in addition, the following information:

a. Marginal information similar to that shown on maps, such as the graphic scale in yards.

b. Some system of grids, usually the atlas grid described photograph figure.



FIGURE 97.—Tandem T-3A composite.

c. Names of towns, streams, mountains, highways, and other important features.

■ 118. CARE IN USE OF PHOTOMAPS.—Photomap users will make their own estimates of the reliability of the information portrayed by examination of the marginal information and by consideration of the basic materials used in their preparation. The date of the aerial photography gives an indication



FIGURE 98.—Reproduced mosaic.

of the probable accuracy of portrayal of cultural features as they now exist. If the photomap is a simple reproduction of a single photograph or composite, it will be understood that the indicated scale is approximate and that over-all scale errors due to tilt and relief displacements will exist. Photomaps from mosaics will be indicated as "controlled" or "uncontrolled." Photomaps made from uncontrolled mosaics are important primarily because of their pictorial value, and should not be considered as accurate for the determination of distances and directions. If the area is relatively flat and the photographs have been taken at fairly constant elevation with little tilt, even the uncontrolled mosaic will approach the dimensional and directional accuracy of the best maps. A photomap from a controlled mosaic may be accepted as reasonably accurate for measurement of distances and directions, despite the fact that image displacements at the junctions of the individual prints will be apparent. When the photomap has been prepared from a mosaic of high accuracy, as explained in paragraph 65*b*, the legend will so state. Such photomaps may be accepted with the same degree of confidence as a first class planimetric map of the same scale.

■ 119. AIDS IN USE OF PHOTOMAPS.—Photomaps reproduced in quantity by photolithography lose some of the clarity, sharpness, and contrast of the original copy. Even in poor reproductions, however, the principal features of the terrain can be discerned by careful study and through the application of general knowledge of terrain characteristics. It will assist the map reader considerably to trace out the drainage system, accentuating the stream lines with a sharp blue pencil, avoiding, at the same time, the obliteration of essential details. In the same manner, the permanent ridge lines may be traced in brown lines, thus enabling the map reader to grasp at a glance the major features of the terrain.

■ 120. METHODS OF REPRODUCTION.—Photomaps are reproduced in quantity by contact printing, by continuous tone lithography, or by halftone lithography. The contact process produces the best results, but is much more expensive and time consuming than lithography. Furthermore, rapid contact printing of large size photomaps requires equipment which is too bulky for field use. In the continuous tone

lithographic process, much of the contrast of tone which appears in the original photograph or mosaic is lost. As a result, many small features become merged into the background and are difficult or impossible to discern. When the original photography has been satisfactory, the best results in quantity reproduction are obtained by halftone photolithography. Reading glass examination of a photomap reproduced by this process, will disclose that the individual images are made up of a series of dots, the darker the object, the denser the dots. Most of the original tone contrast of the photograph is retained. However, in the halftone process also, some details of the landscape such as individual bushes, small houses, etc., may be too small to create a sufficiently distinct dot pattern to render them recognizable. Another feature to be observed in the study of photomaps from mosaics is the changes in tone and contrast between the adjacent sections of the separate photographs used in the preparation of the mosaic. Because of changes in exposure conditions, as well as variations in printing of individual photographs, marked differences in the tone of adjacent sections of the mosaic frequently occur. Such differences in tone should be recognized readily and should not be misinterpreted as actual changes in landscape texture.

INDEX

	Paragraph	Page
Aerial photographs:		
Atlas grid.....	105	159
Care.....	71	101
Compared to map.....	61	87
Contours.....	103	158
Conversion to map.....	69	99
Definition.....	61	87
Direction.....	101	156
Distance.....	100	156
Elevation.....	102	158
Identification.....	76, 79	113, 114
Index and plot.....	70	100
Interpretation.....	76	113
Military features.....	87	127
Military grid.....	106	161
Orientation.....	78, 107	114, 163
Pin points.....	63	95
Relative size of objects.....	81	114
Relief.....	75, 88, 89	110, 127, 129
Reproduced.....	116	177
Scale.....	95, 96	148, 149
Change.....	99	154
Graphic.....	98	154
Scope.....	97	153
Season, effect.....	85	120
Shadow.....	83	116
Shape of objects.....	80	114
Strips.....	64	95
Texture of ground surface, effects.....	82	115
Tilted.....	73-75, 93	102, 147
Tone.....	82	115
Topographical features.....	86	120
Tracing.....	69	99
Training.....	6	5
Types and characteristics.....	62	88
Altitude related to photograph scale.....	62	88
Anaglyph.....	89	129
Anaglyphoscope.....	89	129
Angles:		
Direction.....	16	20
Measurement.....	17, 24	20, 26
Annual change.....	18, 19	20, 22
Area:		
Deflated.....	58	79
Mapped in United States.....	61	87
Atlas grid.....	105	159
Axis of earth.....	4	1
Azimuth.....	20, 21	24
Determination.....	37	57

INDEX

	Paragraph	Page
Back azimuth.....	21	24
Base directions.....	18	20
Bearings.....	20, 21	24
Bleaching.....	69	99
Cameras, types for aerial photographs.....	62	88
Cassiopeia.....	25	28
Change, annual.....	18, 19	20, 22
Charts, navigation.....	4, 41	1, 62
Coast and Geodetic Survey charts.....	9	9
Collimation marks.....	62, 105	88, 159
Color-layer system (relief).....	41	62
Color maps.....	6, 7	5, 7
Compass, magnetic.....	22	25
Composites.....	62	88
Reproduced.....	116	177
Concealment.....	58	79
Contoured maps, training.....	6	5
Contours:		
Approximate.....	46	69
Characteristics.....	42	65
Definition.....	41	62
Depth curves.....	41	62
Interval, defined.....	43	66
Logical.....	47	69
Marginal data.....	8	8
On aerial photograph.....	103	158
Controlled mosaics.....	65	95
Conventional signs.....	7	7
Relief.....	41	62
Conversion factors, angles.....	17	20
Coordinates.....	29	41
Determination.....	37	57
Geographical.....	32	45
Grid.....	33	47
Polar.....	30	42
Rectangular.....	31	43
Spherical.....	32	45
Crest, military and topographical.....	58	79
Curvature of earth.....	60	85
Declination, grid and magnetic.....	19	22
Defilade.....	58	79
Degree (angular measure).....	17	20
Departure.....	18	20
Depth curves.....	41	62
Designation, directional.....	18	20
Dipper, Big.....	25	28
Direction:		
Angular measurement.....	20	24
Base.....	18	20
Determination by field expedients.....	25	28
Determination of unknown.....	37	57
Expression.....	16	20
On aerial photograph.....	101	156
Distance.....	10	10
Determination of unknown.....	37	57
On aerial photograph.....	100	156

INDEX

	Paragraph	Page
Earth:		
Curvature.....	60	85
Size and shape.....	4	1
Elevation.....	39	61
Determination from contours.....	48	71
Of important features.....	44	67
On aerial photographs.....	102	158
Engineer's scale.....	12, 32, 33	11, 45, 47
Equator.....	4	1
Field expedients for determination of direction.....	25	28
Flight line spacing.....	62	88
Focal length of cameras.....	62	88
Foliage.....	58	79
General Land Office maps.....	9	9
Geographic:		
Coordinates.....	32	45
Grid.....	8, 32	8, 45
Index.....	8	8
Gisement.....	19	22
Graphic scale:		
Construction.....	14	15
Marginal data.....	8	8
Grid:		
Atlas.....	105	159
Geographic.....	8, 32	8, 45
Meridian.....	8	8
Method of rectification.....	109	164
Military.....	8, 34, 106	8, 50, 161
Construction.....	38	60
North.....	18, 19	20, 22
Rectangular.....	34	50
Change scale by.....	99	154
System.....	34	50
Continental.....	35	55
Equatorial.....	36	56
To superimpose on map.....	37	57
Zones.....	34, 35	50, 55
Ground forms.....	40	61
Hachures.....	41	62
Height:		
Lens.....	96, 97	149, 153
Related to scale of photograph.....	62	88
Hemisphere.....	4, 34	1, 50
Identification, photograph.....	76	113
Of objects on photographs.....	79	114
Index:		
Adjoining map.....	8	8
Geographic.....	8	8
Of aerial photographs.....	70	100
International Boundary Commission: United States and Canada (maps).....	9	9

INDEX

	Paragraph	Page
Interpretation, aerial photographs.....	76	113
Isogonic lines.....	19	22
Lake survey charts.....	9	9
Latitude.....	4, 32	1, 45
Lens height.....	96, 97	149, 153
Lensatic compass.....	22	25
Lettering.....	7	7
Linear measure.....	10	10
Lines:		
Contour.....	41	62
Form.....	46	69
Isogonic.....	19	22
Master.....	40	61
Ridge and stream.....	40	61
Local magnetic attraction.....	23	26
Location:		
Distant point.....	27	39
One's position.....	26	32
Longitude.....	4, 32	1, 45
Magnetic:		
Attraction, local.....	23	26
Azimuth.....	21	24
Field.....	23	26
Meridian.....	8, 18	8, 20
North.....	18, 19, 24	20, 22, 26
Map:		
Battle.....	5	4
Classification.....	5	4
Compared to aerial photograph.....	61	87
Definition.....	3	1
Marginal information.....	8	8
Measurer.....	12	11
Military use.....	6	5
Orientation.....	26	32
Scales.....	11	11
Titles.....	8	8
Topographic.....	5	4
Training with.....	6	5
Types.....	5	4
Used in training.....	6	5
Map substitute.....	94	148
Scale.....	95	148
March scale (time-distance).....	15	18
Marginal information.....	8	8
Aerial photograph.....	77	113
Photomap.....	117	177
Mask.....	58	79
Measure:		
Angular.....	17	20
Linear.....	10	10
Measurer, map.....	12	11
Meridian.....	4	1
Central.....	19, 35	22, 55
Mil (angular measure).....	17	20

INDEX

	Paragraph	Page
Military:		
Crest.....	58	79
Features on aerial photographs.....	87	127
Grid.....	8, 106	8, 161
Minute (angular measure).....	17	20
Mosaics	65	95
Reproduced.....	116	177
Multiple-lens camera	62	88
Navigation charts	4, 41	1, 62
North:		
Grid.....	18, 19	20, 22
Magnetic.....	18, 19	20, 22
Location on aerial photograph.....	104	158
On aerial photograph.....	101	156
Star.....	25	28
True.....	18, 19	20, 22
Obliques	62	88
Rectification by photography.....	114	174
Orientation	26	32
Aerial photographs.....	78, 107	114, 163
Distant point.....	27	39
Maps.....	26	32
Methods.....	26	32
One's position.....	26	32
Overlays	68	98
Paper, print	66	98
Parallel of latitude	4	1
Perception, stereoscopic	89	129
Photogrammetric instruments	103	158
Photograph. (See Aerial photographs.)		
Photography	84	120
Rectification by.....	114	174
Photomap:		
Aids in use.....	119	181
Care in use.....	118	179
Definition.....	115	175
Marginal data.....	117	177
Reproduction.....	120	181
Training with.....	6	5
Types.....	116	177
Picture points	67	98
Pin points	63	95
Plain verticals (photograph)	62	88
Plumb line, direction with	25	28
Point:		
Picture.....	67	98
Pin.....	63	95
Polar coordinates	30	42
Polaris	25	28
Polaroid anaglyph	89	129
Poles:		
Magnetic.....	19	22
North and South.....	4	1
Position, location on map	26	32
Post route maps	9	9
Print paper	66	98
Prismatic compass	22	25

INDEX

	Paragraph	Page
Profile-----	57	77
Definition and construction-----	57	77
Exaggeration-----	57	77
From contours-----	57	77
Hasty-----	58	79
Method of visibility-----	58	79
Projection-----	4	1
Classification-----	4	1
Definition-----	4	1
Mercator's-----	4	1
Polyconic-----	4	1
Protractor-----	24	26
Pseudoscopic effect-----	93	147
RF. (See Representatives fraction.)		
Radial line, restitution-----	113	170
Rectangular:		
Coordinates-----	31	43
Grid-----	34	50
Protractor, use-----	24	26
Rectification:		
Aerial photographs-----	109, 110	164, 165
By photography-----	114	174
Refraction of light-----	60	85
Relief-----	40	61
Aerial photographs-----	75, 88, 89	107, 127, 129
Interpretation-----	45	67
Stereo effect-----	73	102
Representative fraction (RF)-----	8	8
Determination of scale with-----	14, 96	15, 149
Use with engineer's scale-----	12	11
Use with map measurer-----	12	11
Reproduction (photograph)-----	106, 116, 120	161, 177, 181
Resection, location of point-----	111	168
Restitution-----	108	164
Paper strip method-----	112	169
Scale-----	11	11
Aerial photograph-----	95, 96	148, 149
Change-----	99	154
Graphic-----	98	154
Area and distance relation-----	13	15
Coordinate-----	33	47
Definition-----	11	11
Determination, map-----	14	15
Engineer's-----	12, 32, 33	11, 45, 47
Graphic-----	12	11
Construction-----	14	15
Marginal data-----	8	8
Standard map-----	5	4
Time-distance-----	15	18
Sea level-----	4, 39	1, 61
Season, effect of-----	85	120

INDEX

	Paragraph	Page
Seconds (angular measure)	17	20
Shadow (in photographs)	78, 79, 93	114, 147
Shapes of objects	80	114
Signs, conventional	7	7
For relief	41	62
Size, relative on photographs	81	114
Slope:		
Average	56	77
Between two points	54	75
Conversion of units	55	76
Definition and expression	49	73
Degrees	52	75
Gradient	53	75
Mils	51	73
Percent	50	73
Soil survey maps	9	9
Sources of error (photograph)	72	101
Spherical coordinates	32	45
Standard maps	5	4
Stereo:		
Effects, faulty	93	147
Effects of relief	73	102
Examination	89, 92	129, 143
Fusion	89	129
Pair	89	129
Triplet	89	129
Stereo-comparagraph	103	158
Stereogram	89	129
Stereoscopes	91	133
Contouring with	103	158
Strips, photographic	64	95
Sun, direction by	25	28
Symbols	7	7
Not used on map	8	8
Relief	41	62
T-type camera	62	88
Tactical interpretation, aerial photographs	76	113
Terrain	40	61
Master lines	40	61
Texture (aerial photographs)	82	115
Tilted photographs	93	147
Effect	74, 75	107, 110
Time-distance scales	15	18
Tone (aerial photographs)	82	115
Topographic—		
Crest	58	79
Features (aerial photographs)	86	120
Identification (aerial photographs)	76	113
Maps	5	4
Traverse	28	40
Truth azimuth	21	24
Meridian	8, 18	8, 20
North	18, 19	20, 22

INDEX

	Paragraph	Page
Uncontrolled mosaics-----	65	95
Ursa Major (Big Dipper)-----	25	28
United States Forest Service maps-----	9	9
Vertical:		
Composite-----	62	88
Datum-----	8	8
Interval, contours-----	43	66
Photograph-----	62	88
Visibility -----	58	79
Diagram-----	59	84
Vision, stereo -----	89	129
Watch, to find direction -----	25	28
Watch compass -----	22	25
X-coordinates, origin -----	34	50
X-lines -----	33	47
Y-coordinates, origin -----	34	50
Y-lines -----	19, 33	22, 47
Application in problem-----	24	28



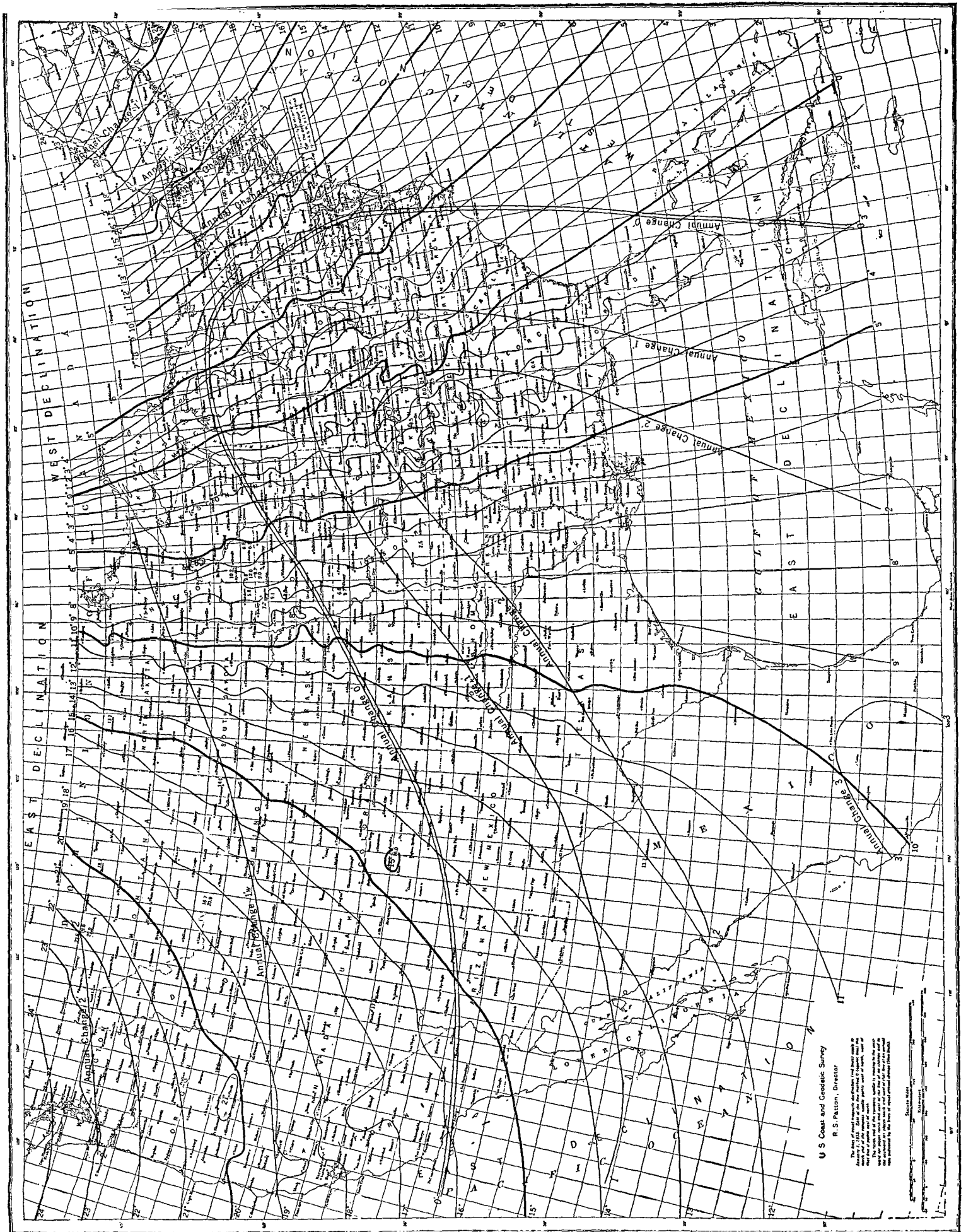

FIGURE 9.—Lines of equal magnetic declination and of equal annual change in United States for 1935.