

MHI
Copy

FM 23-9

DEPARTMENT OF THE ARMY FIELD MANUAL

RIFLE, 5.56-MM, XM16E1

PROPERTY OF
QUARTERMASTER SCHOOL LIBRARY
U. S. ARMY QUARTERMASTER SCHOOL
FORT LEE, VA. 23801



HISTORICAL USE

HEADQUARTERS, DEPARTMENT OF THE ARMY
JULY 1966

HEADQUARTERS
DEPARTMENT OF THE ARMY
WASHINGTON, D.C., 2 February 1968

CHANGE }
No. 1 }

RIFLE, 5.56-MM, M16A1

FM 23-9, 12 July 1966, is changed as follows:

The title is changed to read as shown above.

In paragraphs 1, 3, 5, 6, 10, 15, 16, 20, 22, 23, 25, 31, 32, and 35, wherever the term "XM 16E1" appears, it is changed to read "M16A1."

In figures 1 and 19, the term "XM16E1" is changed to read "M16A1."

Page 3, paragraph 3b. In line 3 "or" is changed to read "of."

Page 3. Paragraph 4a is superseded as follows:
a. *Weights.*

	Pounds
Rifle without magazine and sling-----	6.5
Empty magazine (aluminum, 20 rounds)-----	.2
Full magazine (20 rounds)-----	.7
*Sling, M1-----	.4
Firing weight (fully loaded with sling)-----	7.6
Bipod, M3-----	.6
Bipod case-----	.2
Bayonet-knife, M7-----	.6
Scabbard, M8A1-----	.3

*Sling, small arms, FSN 105-714-9749, is an authorized substitute for sling M1. This sling is extra long and will allow a firer to carry the weapon slung across the front of his body in a position which allows him to take both hands from the weapon, but keep it available for use. It would be especially useful for personnel designated as automatic riflemen or for people who must carry such equipment as radios and binoculars.

Page 5, paragraph 4e. In line 1, "3,150 feet per second (approx.);" is changed to read "3,250 feet per second (approx.)."

Page 6. Paragraph 7 is superseded as follows:

7. Field Stripping

a. Remove the sling.

b. Remove the handguards by placing the butt of the rifle on a flat surface with the muzzle up. Pull down on the sliping until the lower lip of the handguard is clear; pull out and down on the handguard until the upper lip is free of the handguard cap (fig 18). Repeat the same operation to remove the second handguard. Considerable pressure must be used to force the sliping down.

Note: Handguards should not be removed when the upper and lower receiver groups are separated because of potential damage to the forward assist assembly.

c. Place the weapon on a flat surface on its right side with the muzzle to the left. Use the nose of the

cartridge to press the takedown pin (fig. 7) until the upper receiver swings free of the lower receiver (fig. 8).

Caution: The takedown pin does not come out of the receiver.

d. Again using the nose of a cartridge, press the receiver pivot pin (fig. 9). Separate the upper and lower receiver groups (fig. 10) and place the lower receiver group on the table.

Caution: The receiver pivot pin does not come out of the receiver.

e. Pick up the upper receiver group; keep the muzzle to the left. Grasp the charging handle, pressing in on the latch, and pull to the rear (fig. 5) to withdraw the bolt carrier from the receiver. Grasp the bolt carrier and pull it from the receiver (fig. 11). When the bolt carrier is removed, the charging handle will fall free of its groove in the receiver when pulled to the rear (fig. 12). Place the receiver on the table.

f. To disassemble the bolt carrier group, press out the firing pin retaining pin by using the nose of a cartridge (fig. 13). Elevate the front of the bolt carrier and allow the firing pin to drop from its well in the bolt (fig. 14). Rotate the bolt until the cam pin is clear of the bolt carrier key and remove the cam pin by rotating it 90° (1/4-turn) and lifting it out of the well in the bolt and bolt carrier (fig. 15). After the cam pin is removed, the bolt can be removed easily from its recess in the bolt carrier (fig. 16). Remove the extractor by first pushing the extractor pin out with the firing pin, then, while maintaining pressure on the extractor with the index finger, withdraw the firing pin from the extractor pinhole. Release the pressure from the extractor and remove. The extractor should be disassembled only when necessary for cleaning, and disassembly should be supervised. Since the extractor pin is quite small, it should be handled with care to prevent loss or damage.

Note. The extractor spring should not be removed from the extractor. If the spring falls out of its recess it should be replaced by the unit armorer.

g. Using the index finger of the right hand, push in on the buffer assembly. With the nose of a car-

tridge, or the tip of the firing pin, push down on the buffer retainer. Depress the hammer to the rear (downward) sufficiently to allow the buffer assembly to clear the hammer. Remove the buffer assembly and the spring (fig. 17).

Note. The action spring is under pressure and care must be taken in removing it.

h. This completes field stripping (fig. 19).

Note. Detailed disassembly consists of removing the remaining operating parts from the lower receiver (fig. 20) and is not authorized at user and/or organizational level. The individual soldier has no need to disassemble the weapon beyond field stripping. Only qualified maintenance personnel are authorized to remove any other parts from the weapon.

Caution: Steps b and g above should be performed only when absolutely necessary for care and cleaning.

Page 13. Paragraph 8 is superseded as follows:

8. Assembly

To assemble the rifle, reverse the procedures of disassembly.

a. To assemble the buffer assembly, insert the assembly, spring end first, into the lower receiver extension, depress the cocked hammer to allow passage of the buffer assembly, depress the buffer retainer with the nose of a cartridge, or tip of the firing pin, seat the buffer assembly and release the buffer retainer.

b. To assemble the bolt carrier group, grasp the bolt and the extractor with spring. Seat the extractor in the extractor recess, apply pressure on the extractor to align the pinhole and insert the extractor pin. Pick up the bolt carrier, key up and to the front, insert the bolt into the front of the bolt carrier, insuring that the ejector is down and to the left. Replace the cam pin into its well and rotate the cam pin 90° (¼-turn) to align the holes for the firing pin in the bolt and cam pin. Grasp the lugged rim of the bolt and turn until the cam pin is directly under the bolt carrier key. Insert the firing pin through the open end of the bolt carrier and seat fully. Insert the firing pin retaining pin (if resistance is encountered, rotate pin while inserting).

Caution: Do not attempt to spread the slotted end of the firing pin retaining pin.

Note. Check for proper assembly by elevating the front of the bolt. If the firing pin drops out, the firing pin retaining pin is not between the front and rear spool and the bolt carrier group is improperly assembled.

c. Grasp the upper receiver with the carrying handle up. Place the charging handle into the groove in the top of the upper receiver. The lugs on the charging handle must be seated in their grooves in the receiver. Place the bolt carrier group into the open end of the receiver, insuring that the bolt carrier key is in the slot on the underside of the charging handle and the bolt is forward in the unlock position. Push forward on the bolt carrier group and charging handle until fully seated.

d. Place the upper receiver group and lower receiver group together and reseat the receiver pivot pin.

e. With the hammer cocked and selector lever in the safe position, close the weapon and seat the takedown pin.

f. Replace the handguards and be sure that the slipping is fully seated on the lower lip of both sections of the handguards. Care must be taken to prevent damage to the upper and lower lips and to insure proper seating.

g. A complete function check of the rifle consists of checking the operation of the weapon while the selector is in the SAFE, SEMI, and AUTO positions. The following sequence is used for a rapid, complete check. Any portion of the check may be used alone to determine the operational condition of any specific fire selection.

Note. Disengage the takedown pin and open receivers. Hammer shall be in the cocked position.

- (1) *SAFE position.* Pull trigger, hammer should not fall.
- (2) *SEMI position.* Pull trigger, hammer should fall. Hold trigger to rear, recock hammer and release trigger. Hammer should transfer from hammer hooks and disconnect to the hammer and sear engagement.
- (3) *AUTO position.* Pull trigger, hammer should fall. Hold trigger to the rear and recock hammer. Hammer is now under the automatic sear. Still holding trigger to the rear, push forward on automatic sear. The hammer should fall. Still holding trigger to the rear, recock hammer, release trigger and push forward on automatic sear. Hammer should transfer to the sear engagement. Move selector lever to SAFE or SEMI position. Close receivers and engage takedown pin.

Caution: Failure to move selector lever to SAFE or SEMI position, before closing receivers, will damage automatic sear.

- (4) *SEMI position.* Pull charging handle to the rear. Make certain chamber is clear, then release charging handle. Pull the trigger. Hammer should fall.

Page 14, figure 17. In the caption, "action spring guide assembly" is changed to read "buffer assembly."

Page 17. Paragraph 9 is superseded as follows:

9. Operation

a. Loading the Magazine.

- (1) The magazine has a capacity of 20 rounds and may be loaded with any amount up to that capacity. The magazine follower has a raised portion generally resembling the outline of a cartridge.
- (2) Cartridges are loaded into the magazine so that the tips of the bullets point in the same direction as the raised portion of the follower (fig. 21).

Note. Rounds in the magazine should be removed and checked daily for corrosion and dents and wiped off with a dry cloth.

Caution: Do not load or attempt to load more than 20 rounds in the magazine. Overloading will deform the lips of the magazine and cause malfunctions.

b. *Unloading the Magazine.* To prevent damage to the lips of the magazine, removal of ammunition is accomplished in the following manner:

- (1) Hold the magazine in the left hand with the open end away from the body, nose of the cartridge down (1, fig. 21.1).
- (2) Using the nose of a cartridge, depress the center of the second round in the magazine allowing the first round to drop out of the magazine (2, fig. 21.1). This process is repeated until all rounds have been removed from the magazine except the last.
- (3) To remove the last round, use the nose of a cartridge and depress the follower allowing the last round to drop out of the magazine (3, fig. 21.1).

c. Disassembly and Assembly of the Magazine.

- (1) To properly perform maintenance on the magazine, it must be disassembled.
- (2) The magazine is disassembled in the following manner:
 - (a) Hold the magazine in the left hand, open end to the left, short edge near the body.
 - (b) Insert the nose of a cartridge into the hole in the base of the magazine, depressing the spring steel lock band and at the same time exerting a slight pressure on the base pushing it away from the body or toward the long edge of the magazine (1, fig. 21.2).
 - (c) Slide the base forward until it is free of the tabs (2, fig. 21.2).

Note. Keep the left thumb over the follower spring to prevent it from jumping out of the magazine.

- (d) To remove the follower spring, disengage it from the tabs on the magazine first from one side and then the other until it is free of the magazine (3, fig. 21.2).
 - (e) The follower, attached to the end of the magazine must be "canted" in order to clear the tabs (4, fig. 21.2).
 - (f) Clean the exterior and interior of the magazine with a dry patch. The magazine is kept dry. The magazine is lightly oiled.
- (3) To assemble the magazine, the parts are replaced in the reverse order of removal.
 - (a) Place the small end of the follower in the magazine, slipping it under the spring steel lock band then cant the follower to clear the magazine tabs; insure that the follower is seated properly prior to feeding the spring into the magazine.
 - (b) Feed the spring into the magazine by pushing down and from side to side until the last coil is under the tabs.
 - (c) Hold the spring down with the thumb and insert the base under the first set of tabs.
 - (d) Depress the spring steel lock band; seat the base of the magazine insuring that the lock band is fully engaged. Depress the follower several times to insure that it moves freely.

d. Loading the Rifle.

- (1) With the hammer cocked, place the selector lever on **SAFE** (fig. 3). The magazine may be inserted with the bolt opened or closed. However, the soldier should be taught to load the weapon with the bolt open. This will reduce the possibilities of a first round stoppage and save the time needed to pull the charging handle to the rear.
- (2) Hold the stock of the rifle under the right arm with the right hand grasping the pistol grip, and point the muzzle in a safe direction. With the left hand, insert a loaded magazine into the magazine housing. Push upward until the magazine catch engages and holds the magazine. Depress the upper portion of the bolt catch (fig. 22) with the thumb of the left hand, allowing the bolt to close, chambering a round. If the bolt is closed when the magazine is inserted, pull the charging handle fully to the rear with the right hand and release it.

Note: Left-handed personnel should follow the procedure above by reversing the position of

their hands, using the left index finger to depress the upper portion of the bolt catch.

Note. Do not "ride" the charging handle forward with the right hand. If the charging handle is eased forward from the open position, the bolt may fail to lock. If the bolt fails to go fully forward, use the forward assist assembly (fig. 1). To operate, strike the forward assist with the heel of the right hand.

- (3) The bolt catch will hold the bolt carrier to the rear after the last round is fired. To change magazines for reloading, press the magazine catch button and remove the empty magazine from the weapon. Place the new magazine into the magazine housing and push up until fully seated (*b*(2) above).

e. Unloading. To unload the rifle and make it safe, the firer first places the selector lever on safe, presses the magazine catch button and removes the magazine, pulls the charging handle to the rear, inspects the chamber to insure it is clear, locks the bolt carrier to the rear by depressing the lower portion of the bolt catch, and returns the charging handle forward. The rifle is clear *only* when no round is in the chamber, the magazine is out, the bolt carrier is to the rear, and the selector lever is on the *SAFE* setting.

Figures 21.1 and 21.2 are added as follows:

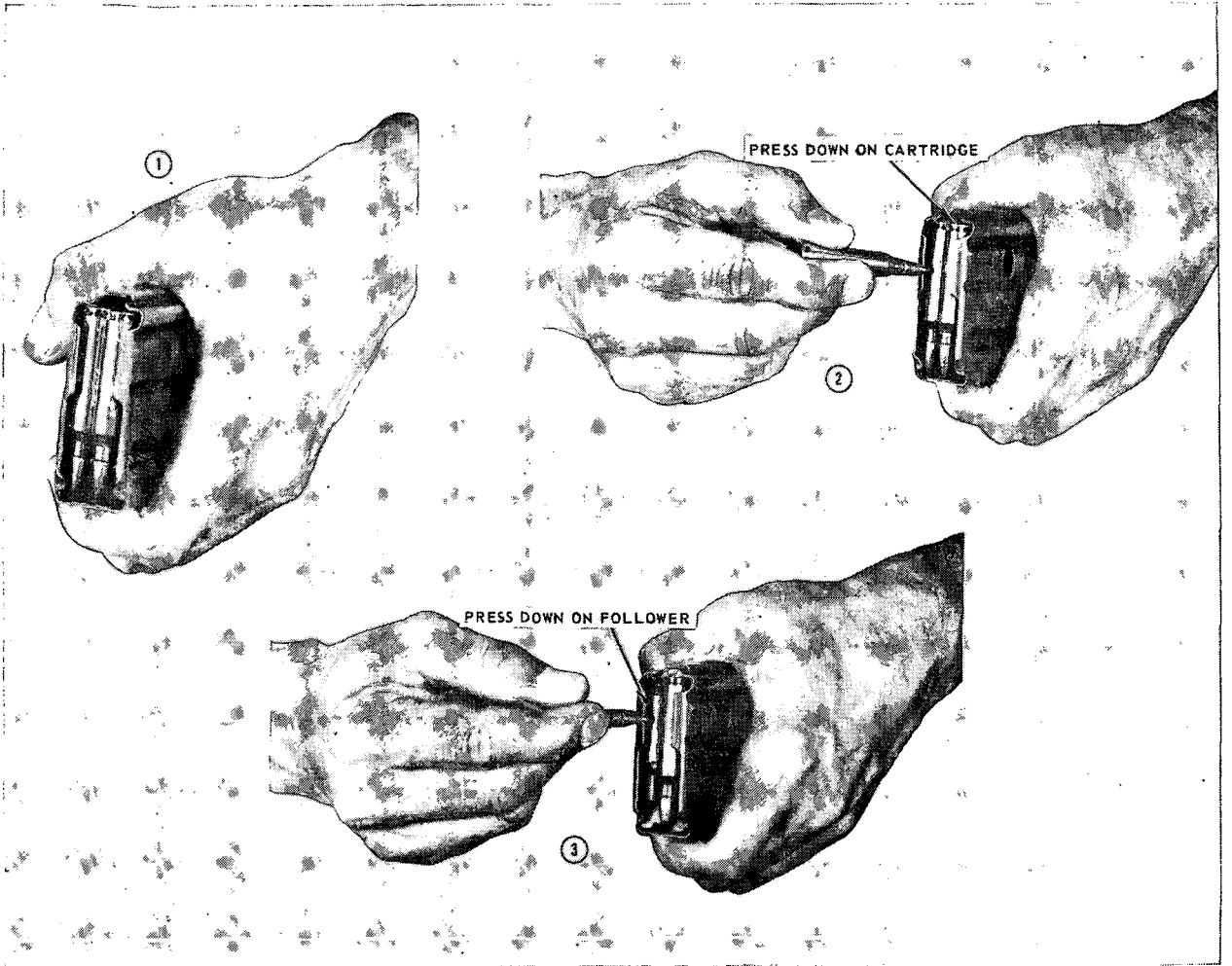

Figure 21.1 Unloading the magazine.

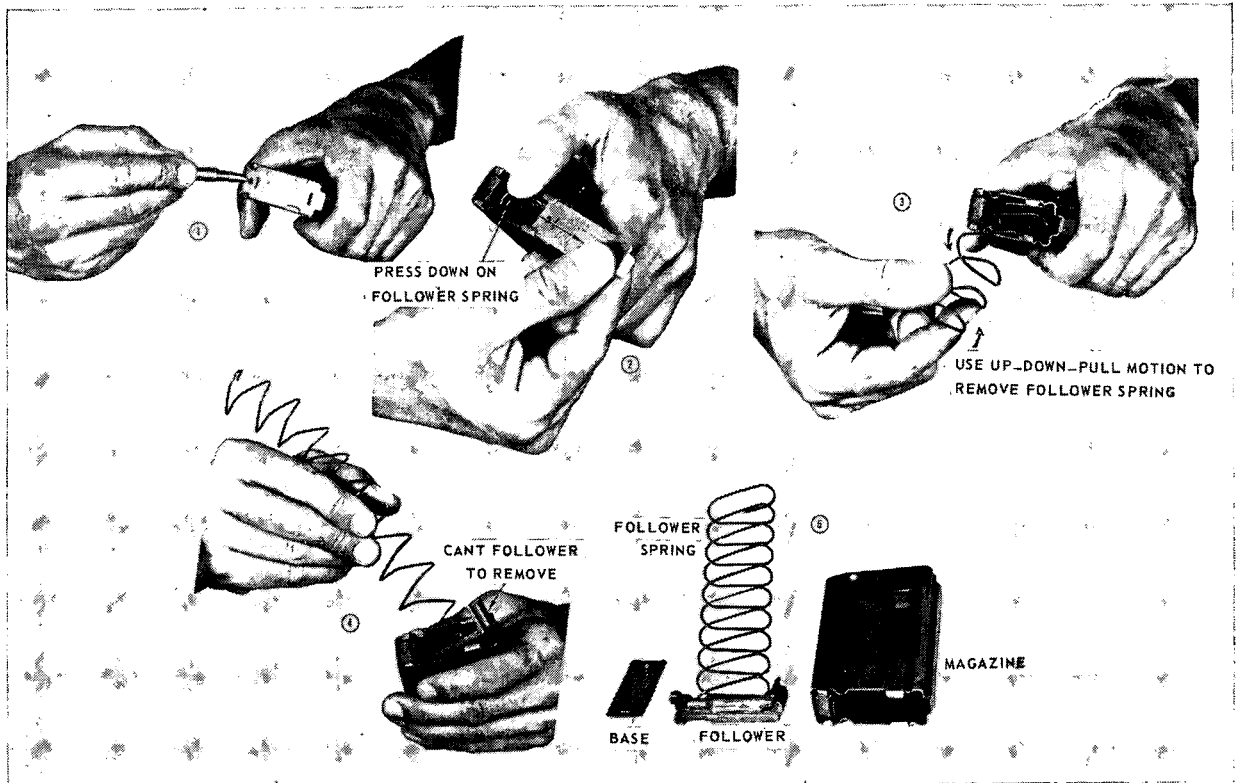

Figure 21.2. Disassembly of the magazine.

Page 27. Paragraph 11 is superseded as follows:

11. Maintenance

a. *General.* A clean, properly oiled and maintained rifle loaded with clean ammunition will shoot when needed. In order to keep the M16A1 rifle and ammunition in good condition they must have daily care and cleaning. Under bad weather conditions certain key parts of the rifle and ammunition may need care and cleaning several times a day. To insure proper functioning of the M16A1 rifle, it is imperative that the following procedures be followed:

b. *Cleaning.* Thoroughly clean all metal surfaces of the rifle with bore cleaner (solvent cleaning compound, CR). Special attention must be given to the following areas in order of their importance to functioning:

(1) *Chamber.* Clean the chamber with a chamber brush dipped in bore cleaner. Wipe with clean dry swabs (cleaning patches) and apply a light coat of LSA (lubricating oil, semifluid, MIL-L-46000A).

(2) *Bolt carrier group.*

(a) *Carrier key.* Clean the bolt carrier key

with a bore brush dipped in bore cleaner. A used or worn brush should be used if available. Wipe with a clean, dry pipe cleaner (FSN 9920-292-9946).

(b) *Locking lugs.* Clean the locking lugs of the bolt, extractor and extractor well using a small brush and bore cleaner. Remove any accumulation of dirt, carbon or oil from the firing pin, the external and internal surfaces of the bolt and bolt carrier using a small brush and bore cleaner. Also clean the firing pin hole of the bolt using a pipe cleaner soaked with bore cleaner. Wipe all parts with a clean dry swab, rag or pipe cleaner. Apply a generous coat of LSA to the exterior surfaces of the bolt carrier, a light coat of LSA on the bolt, interior of the bolt carrier and one drop of LSA in the carrier key.

(c) *Magazine.* Must be disassembled and wiped clean with a clean, dry rag. Lightly oil the magazine spring only by wiping with a rag dipped in LSA.

(d) *Barrel bore.*

1. Attach a bore brush to an assembled

cleaning rod, dip in bore cleaner, and brush the bore thoroughly. Brush the bore from chamber to muzzle using straight through strokes.

Note. Do not reverse direction of brush while in the bore. Push the brush through the bore until it extends beyond the muzzle. Continue until the bore is well covered with bore cleaner. Remove the brush from the cleaning rod, attach the slotted tip, and dry the bore by pushing through clean dry swabs. Continue until swabs come out clean and dry. Care should be used to support the cleaning rod while inserting to prevent flexing or breakage.

2. After cleaning, lubricate the bore with a lightly oiled swab to prevent rust and pitting. Lightly oil the lugs in the barrel extension.
- (e) *Upper receiver.*
1. Use a swab or brush to clean the upper receiver of powder fouling with bore cleaner.
 2. Clean the protruding gas tube in the receiver with a worn bore brush

attached to a section of cleaning rod. The top of the gas tube can be cleaned by inserting the rod and brush in the back of the receiver. The sides and bottom of the gas tube can be cleaned from the bottom of the receiver.

3. Wipe all parts dry.
 4. Apply a generous coat of LSA to the interior surfaces of the upper receiver.
- (f) *Lower receiver.*
1. Cleaning will not require detailed disassembly of the lower receiver group. Using a swab or bristle brush with bore cleaner, remove carbon, dirt and sand from the lower receiver. Dry and generously lubricate with LSA.
 2. After extensive use, acids caused by perspiration should be removed from exterior surfaces using a rag or swab with bore cleaner, then wipe dry and apply a light coat of LSA.

Page 28. Figure 33 is superseded as follows:

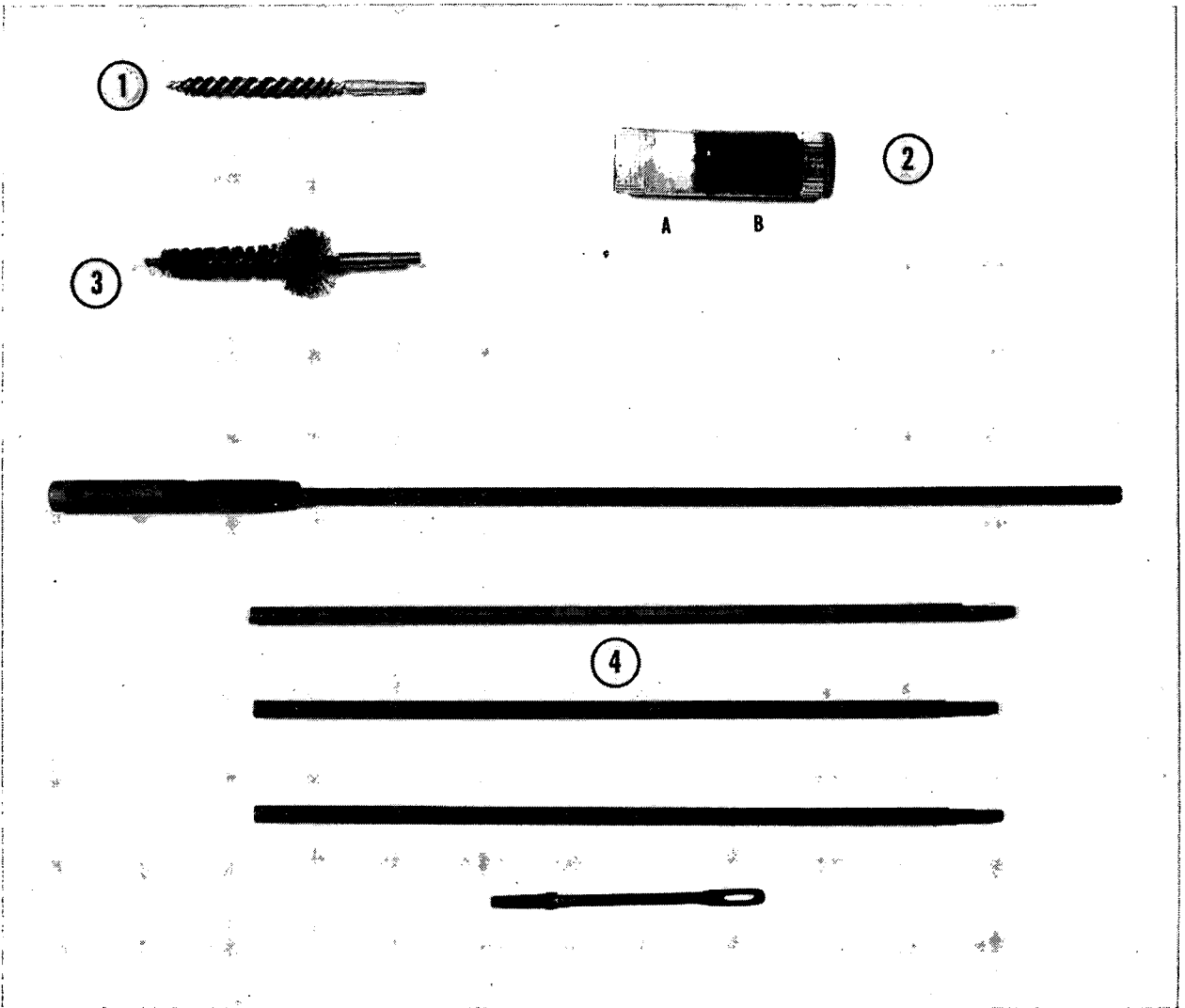

- 1 Bore brush
- 2 Lubricant Case
 - a. Grease
 - b. Oil
- 3 Chamber and receiver brush
- 4 Cleaning rod

Figure 33. Cleaning equipment.

Page 29. Figure 35 is superseded as follows:

Interval and sequence No.			Operator's daily schedule		
Before firing	During firing	After firing	Item to be inspected	Procedures	Paragraph reference
1-----			Rifle-----	Wipe oil from bore and chamber-----	11b.
2-----			Ammunition-----	Wipe oil, grease, sand, and other foreign matter from the ammunition with a dry swab.	9a.
3-----			Rifle-----	Retract bolt to assure free movement between bolt carrier and gas tube.	11b.
4-----			Rifle-----	Function check to assure proper operation-----	8g.
5-----			Rifle-----	Check magazine for positive retention and functioning of bolt catch.	10c(2).
		6	Rifle-----	Clean and lubricate. Pay particular attention to cleaning the bolt carrier key and chamber.	11b.

Figure 35. Preventive maintenance checks and services.

Page 30. Paragraph 12c is added after paragraph 12b.

c. To clean the detent and detent spring on the front and rear sights, apply several drops of LSA

and depress the detent several times. Wipe excess oil off with a dry swab.

Page 30. Section IV is superseded as follows:

Section IV. STOPPAGES, IMMEDIATE AND REMEDIAL ACTION

14. Stoppages

A stoppage is any unintentional interruption in the cycle of functioning. Immediate or remedial action must be taken to clear the stoppage.

15. Immediate Action

Immediate action is the unhesitating application of a probable remedy to reduce a stoppage without investigating the cause. Immediate action to clear a stoppage with the M16A1 rifle is as follows:

a. Strike the forward assist assembly to insure that the extractor has engaged the round. Tap upward on the bottom of the magazine to insure it is fully seated. Pull the charging handle fully to the rear. Observe for ejection of a complete cartridge or cartridge case.

b. If a cartridge or case is ejected, release the charging handle to feed a new round (do not ride the charging handle forward). Strike the forward

assist assembly to assure bolt closure. Attempt to fire the weapon. If the weapon fails to fire, it must be inspected to determine the cause of malfunction and appropriate action taken.

c. If a cartridge or cartridge case is not ejected, check for a round in the chamber. If the chamber is clear, release the charging handle to feed a round, strike the forward assist assembly, and attempt to fire. If the weapon still fails to fire, it must be inspected to determine the cause of malfunction and appropriate action taken.

d. If a cartridge or case is noted in the chamber, it must be removed before attempting to reload and recycle the weapon.

15.1. Remedial Action

When the application of immediate action fails to reduce the stoppage the cause of the stoppage will require investigation by remedial action. A suggested troubleshooting guide is shown in the chart below.

Remedial Action Troubleshooting Guide

<i>Stoppage</i>	<i>Cause</i>	<i>Remedy</i>	<i>Repair responsibility</i>		
			<i>User</i>	<i>Unit armorer</i>	<i>DS/GS Maint spt</i>
Failure to FIRE-----	Worn or broken firing pin-----	Replace firing pin-----	-----	X	-----
	Excessive oil in firing pin recess.	Remove oil-----	X	-----	-----
	Defective hammer spring-----	Replace hammer spring-----	-----	-----	X
Failure to UNLOCK--	Firing pin improperly assembled.	Reassemble properly-----	X	-----	-----
	Gas tube seized by bolt carrier key.	Clean gas tube and bolt carrier key.	X	-----	-----
Failure to UNLOCK--	Broken bolt cam pin-----	Replace bolt cam pin-----	-----	X	-----
	Gas leakage-----	Replace worn parts-----	-----	-----	X
	Restricted gas port or gas tube.	Clean gas port or replace gas tube.	-----	-----	X
	Worn, broken or missing bolt (piston) rings.	Replace bolt (piston) rings-----	-----	-----	X
Failure to EXTRACT.	Dirty locking lugs-----	Clean locking lugs-----	X	-----	-----
	Burred locking lugs-----	Repair locking lugs or replace defective parts.	-----	-----	X
	Carbon buildup under extractor.	Clean under extractor-----	X	-----	-----
	Worn or broken extractor parts.	Replace worn or broken extractor parts.	-----	X	-----
	Dirty or badly pitted chamber.	Clean chamber. Replace weapon.	X	X	-----
Failure to EJECT-----	Dirty or corroded ammunition.	Replace ammunition-----	X	-----	-----
	Stuck, worn or broken ejector parts.	Oil ejector parts. Replace worn or broken ejector parts.	X	X	-----
	Restricted recoil caused by binding, dirty parts, or gas leakage.	Clean weapon. Replace defective parts.	X	-----	X
Failure to COCK in "SEMI" position.	Worn or broken disconnect (hook).	Replace disconnect-----	-----	-----	X
	Weak, broken or missing disconnect spring.	Replace disconnect spring-----	-----	-----	X
	Worn trigger nose-----	Replace trigger-----	-----	-----	X
	Bolt carrier group binding-----	Replace weapon-----	-----	X	-----
	Missing bolt cam pin-----	Replace bolt cam pin-----	-----	X	-----

Caution: This is a dangerous condition, do not fire weapon.

Caution: In case of accidental immersion, or in cases where rainwater may have gotten in the barrel, and under conditions where complete and thorough cleaning is impossible, insure that the barrel is drained of water. Failure to do so may cause serious damage to the rifle. Remove water from the barrel in the following manner:

1. Point the muzzle down and pull the charging handle back to unseat the chambered round. (Water cannot drain from the barrel with a round fully seated, as the cartridge case acts as a seal.)
2. Allow the water to drain out. Small

droplets remaining in the bore will not create a hazard.

3. Strike the forward assist to make sure the round is seated in the chamber and the bolt is locked.

Page 30, paragraph 17b. The following sentences are added at the end of the paragraph:

The use of 100 percent tracer may cause deposits of bullet-jacket material (metal fouling) to form in the bore and rifling grooves of the barrel. They are extremely difficult to remove and constitute a potential safety hazard. Therefore, when tracer is fired it will be intermixed with

ball ammunition in a ratio no greater than 1:1 with a preferred ratio of 4:1.

Page 31. Paragraph 19*g* is added after paragraph 19*f*.

g. Badly dented cartridges, cartridges with loose bullets, or otherwise defective rounds should not be fired. This ammunition must be reported promptly to the technical service representative under whose supervision the ammunition for the unit involved is maintained and issued.

Page 43, paragraph 25*b*(1). In line 3, "magazine feedway" is changed to read "magazine housing."

Page 45, paragraph 25*c*(1). In line 10, "magazine feedway" is changed to read "magazine housing."

Page 55. Paragraph 26*a*(1) is superseded as follows:

- (1) *Semiautomatic fire.* Semiautomatic fire is employed in any situation where a high degree of accuracy is required to hit a small point target; e.g., bunker apertures, windows, and scattered formations or single enemy personnel or, where the range to the target is in excess of 460 meters. This method of employment consumes the least amount of ammunition and is the most effective. Rapid trigger

By Order of the Secretary of the Army:

Official:

KENNETH G. WICKHAM,
Major General, United States Army,
The Adjutant General.

Distribution:

To be distributed in accordance with DA Form 12-11 requirements for Rifle 5.56-MM, XM16E1.

manipulation should be employed to deliver a heavy volume of fire to engage a small group of the enemy. When engaging a formation a specific individual in the group should be selected and engaged for maximum effectiveness rather than firing at the group in general.

Page 55. Paragraph 26*a*(2)(*a*) is superseded as follows:

- (*a*) When engaging enemy mass formations at ranges out to 460 meters.

Page 58, paragraph 28*b*. In line 10, "magazine feedway" is changed to read "magazine housing."

Page 59. After paragraph 29*d* the following note is added:

Note. Adjusting the magazine catch: the magazine catch should hold the magazines firmly but not interfere with the magazine removal when the catch button is pressed. To adjust, press in on the catch button with the nose of a cartridge or the end of the cleaning rod, pushing the catch out far enough (on left side of weapon) to clear the catch housing. To tighten turn the magazine catch clockwise, to loosen turn counterclockwise.

Page 64, paragraph 31*a*. In lines 2 and 7 "spring loaded stud" is changed to read "detent." In subparagraph *b*, lines 2 and 5, "spring loaded stud" is changed to read "detent."

HAROLD K. JOHNSON,
General, United States Army,
Chief of Staff.

FIELD MANUAL }
 No. 23-9 }

HEADQUARTERS
 DEPARTMENT OF THE ARMY
 WASHINGTON, D.C., 12 July 1966

RIFLE, 5.56-MM, XM16E1

	Paragraphs	Page
CHAPTER 1. INTRODUCTION		
Section I. General	1, 2	3
II. Characteristics	3, 4	3
CHAPTER 2. MECHANICAL TRAINING		
Section I. Disassembly and assembly	5-8	6
II. Operation and functioning	9, 10	17
III. Care and cleaning	11-13	27
IV. Stoppages and immediate action	14, 15	30
V. Ammunition	16-18	30
VI. Destruction of materiel to prevent enemy use	20, 21	31
CHAPTER 3. MARKSMANSHIP TRAINING		
Section I. Preparatory marksmanship	22-25	32
II. Automatic fire	26-29	55
CHAPTER 4. SIGHT ADJUSTMENT AND BATTLESIGHT ZERO		
Section I. Sight adjustment	30-33	64
II. Battlesight zero	34-36	65
APPENDIX. REFERENCES		69

*This manual supersedes FM 23-9, 25 January 1965.

Chapter 1

INTRODUCTION

Section I. GENERAL

1. Purpose and Scope

This manual provides guidance for presenting instruction with the Rifle, 5.56-mm, XM16E1. It contains a detailed description of the rifle and its general characteristics, procedures for disassembly and assembly, operation and functioning of the rifle, types of ammunition, and maintenance. When supplemented by FM 23-71 and FM 23-16 it provides information in sufficient detail for conducting marksmanship training with the rifle. This manual is applicable to both nonnuclear and nuclear warfare.

2. Responsibilities of Commanders

Users of this manual are encouraged to submit recommended changes or comments to improve the manual. Comments should be keyed to the specific page, paragraph, and line of text in which the change is recommended. Reasons should be provided for each comment to insure understanding and complete evaluation. Comments should be forwarded direct to the Commandant, U.S. Army Infantry School, Fort Benning, Ga., 31905.

Section II. CHARACTERISTICS

3. Description of the Rifle

a. The rifle, XM16E1 (fig. 1), is a 5.56-mm, magazine-fed, gas-operated, air-cooled, shoulder weapon. It is designed for either semiautomatic or full automatic fire through the use of a selector lever.

b. The rifle is equipped with a flash suppressor which also serves as a stationary piston permitting the launching of rifle grenades without the use of supplementary attachments.

Caution: Use of this weapon for rifle grenade launching purposes is not presently authorized.

c. The barrel is surrounded by two aluminum-lined fiberglass handguards which serve as a forearm. The handguards are notched to permit air to circulate around the barrel, and further serve to protect the gas tube.

d. A hard rubber pad is attached to the butt of the stock to partially reduce the effects of recoil.

e. A forward assist assembly located on the right rear of the upper receiver permits the clos-

ing of the bolt when this is not done by the force of the action spring.

f. A "clothespin" bipod is used in prone and foxhole positions. The bipod is attached to the barrel directly beneath the front sight between the bayonet lug and the front sling swivel (fig. 2).

g. The trigger guard is easily adaptable to winter operations. A spring-loaded retaining pin is depressed with a cartridge point to allow ready access to the trigger with arctic mittens.

h. A dust cover is provided to prevent dirt or sand from getting into the rifle. The dust cover should be closed during periods when firing is not anticipated. It will open automatically by the forward or rearward movement of the bolt carrier.

4. General Data

a. Weights.

Rifle without magazine and sling	6.5 lb.
Empty magazine (aluminum, 20 rounds)2 lb.

Full magazine (20 rounds) -----	.7 lb.
Sling, M1 -----	.4 lb.
Firing weight (fully loaded with sling) -----	7.6 lb.
Bipod, M3 -----	.6 lb.
Bipod case -----	.2 lb.
Bayonet-knife, M7 -----	.6 lb.
Scabbard, M8A1 -----	.3 lb.

b. Lengths.

Rifle with bayonet-knife, M7 -----	44.25 in.
Rifle overall with flash suppressor -----	39 in.
Barrel (with flash suppressor) -----	21 in.
Barrel (without flash suppressor) -----	20 in.

c. Sights.

Front-----	Adjustable click-type post. Each click equals 2.8 centimeters per every 100 meters of range.
Rear-----	Adjustable, flip type. Normal range setting is for 0 to 300 meters. Long-range setting (L), 300 to 500 meters. Each notch of the windage drum equals 2.8 centimeters per every 100 meters of range.
Sight radius-----	19.75 inches.

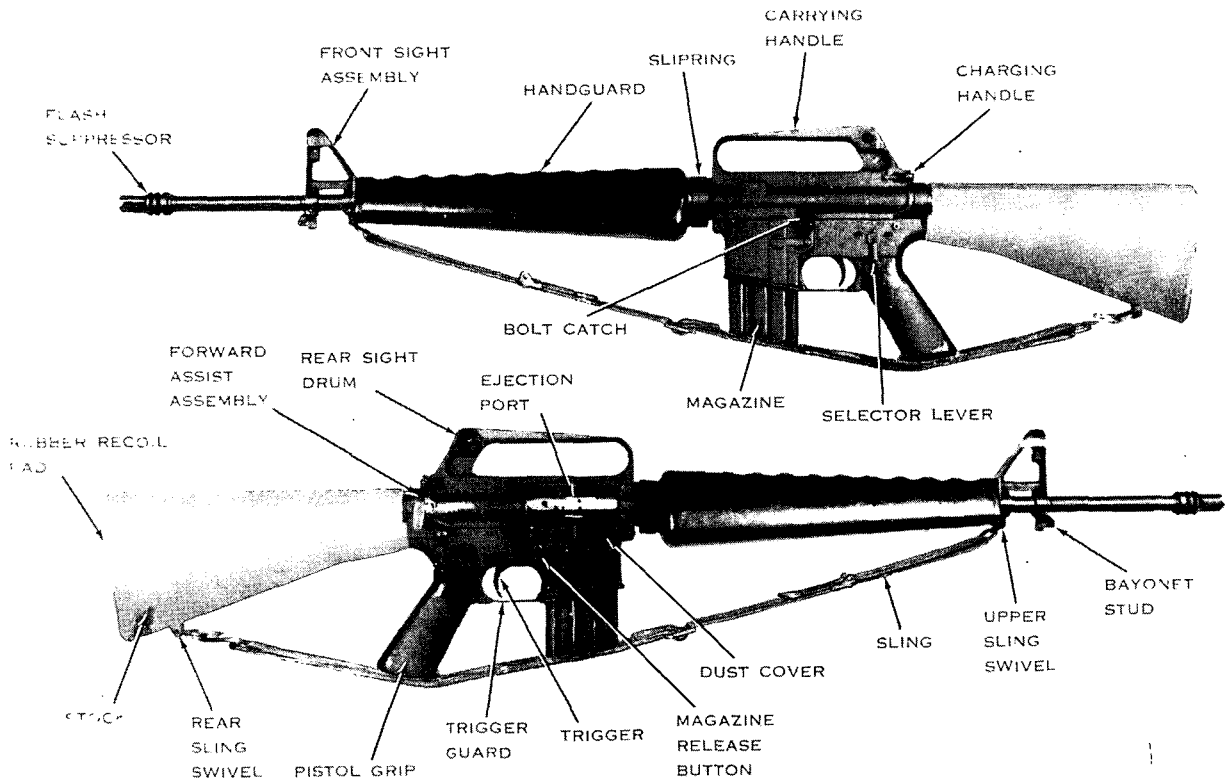

Figure 1. Rifle, 5.56-mm, XM16E1, right and left side views.



Figure 2. Attaching the bipod.

d. Ammunition.

Caliber 5.56-mm (complete
 round) M193.....179 grains.
 Projectile.....55 grains.
 Types.....Ball (standard)
 Tracer (standard)
 Blank (under development).

e. Operational Characteristics.

Muzzle velocity.....3,150 feet per second
 (approx).
 Muzzle energy
 (at the muzzle).....1,300 foot-pounds (approx).
 Cyclic rate of fire.....700 to 800 rounds per minute.
 Maximum rate of fire:
 Semiautomatic.....45 to 65 rounds per minute.
 Automatic.....150 to 200 rounds per minute.
 Sustained rate of fire...12 to 15 rounds per minute.
 Maximum range.....2,653 meters.
 Maximum effective range...460 meters.

f. Terms.

Cyclic rate of fire.....The rate at which a weapon
 fires automatically.
 Sustained rate of fire.....Actual rate of fire that a
 weapon can continue to de-
 liver for an indefinite
 length of time without seri-
 ously overheating.
 Maximum rate of fire.....The maximum number of
 rounds the average rifleman
 can fire in 1 minute, disre-
 garding hits on the target.
 Maximum range.....The greatest distance that a
 weapon can fire.
 Maximum effective range...The greatest distance at
 which a weapon may be ex-
 pected to fire accurately to
 inflict casualties or damage.

Chapter 2

MECHANICAL TRAINING

Section I. DISASSEMBLY AND ASSEMBLY

5. General

a. The purpose of mechanical training is to give the individual soldier a knowledge of the working parts of the XM16E1 so that he will understand its operation, be able to locate and reduce stoppages, and properly maintain the weapon.

b. The individual soldier is authorized to disassemble the XM16E1 to the extent called "field stripping" (para 7). This can be accomplished without supervision and is adequate for normal maintenance.

c. The frequency of disassembly and assembly should be kept to the minimum consistent with proper maintenance and instructional requirements.

d. The XM16E1 is easily disassembled and assembled. No force is needed to accomplish disassembly or assembly.

e. As the weapon is disassembled, the parts should be laid out on a table or other clean surface in the order of removal, from left to right. This makes assembly easier because the parts are assembled in the reverse order of disassembly. Nomenclature (the names of the parts) should be taught as the weapon is disassembled and assembled to enable the soldier to better understand further instruction on the weapon.

6. Clearing the XM16E1

The first consideration in handling any weapon is to make it safe by clearing it. To clear the XM16E1 rifle, place the butt against the right thigh and—

a. Attempt to point the selector lever toward SAFE (fig. 3). If the weapon is *not* cocked, the selector lever *cannot* be pointed toward SAFE. If this is the case, do *not* cock the weapon at this

time; instead, go on to the next step in clearing the weapon.

b. Remove the magazine by grasping it with the right hand (the fingers curled around the front of the magazine, the thumb placed on the magazine catch button), applying pressure on the magazine catch button with the thumb, and pulling the magazine straight out of the weapon (fig. 4).

c. Lock the bolt open by grasping the charging handle with the thumb and forefinger of the right hand, depressing the charging handle latch with the right thumb, and pulling to the rear (fig. 5); press the bottom of the bolt catch with the thumb or forefinger of the left hand (fig. 6) when the bolt is fully rearward. Allow the bolt to move slowly forward until it engages the bolt catch, and return the charging handle to its forward position.

d. Inspect the receiver and chamber of the weapon by looking through the ejection port to insure that these areas contain no ammunition.

e. Check the selector lever to insure that it points toward SAFE (fig. 3) and allow the bolt to go forward by depressing the upper portion of the bolt catch.

Caution: Selector must be in the safe position to prevent damage to the automatic sear.

7. Field Stripping

a. Remove the sling and place the rifle on a table or flat surface, muzzle to the left.

b. Keeping the muzzle to the left, turn the weapon on its right side. Use the nose of a cartridge to press the takedown pin (fig. 7) until the upper receiver swings free of the lower receiver (fig. 8).

Caution: The takedown pin does not come out of the receiver.

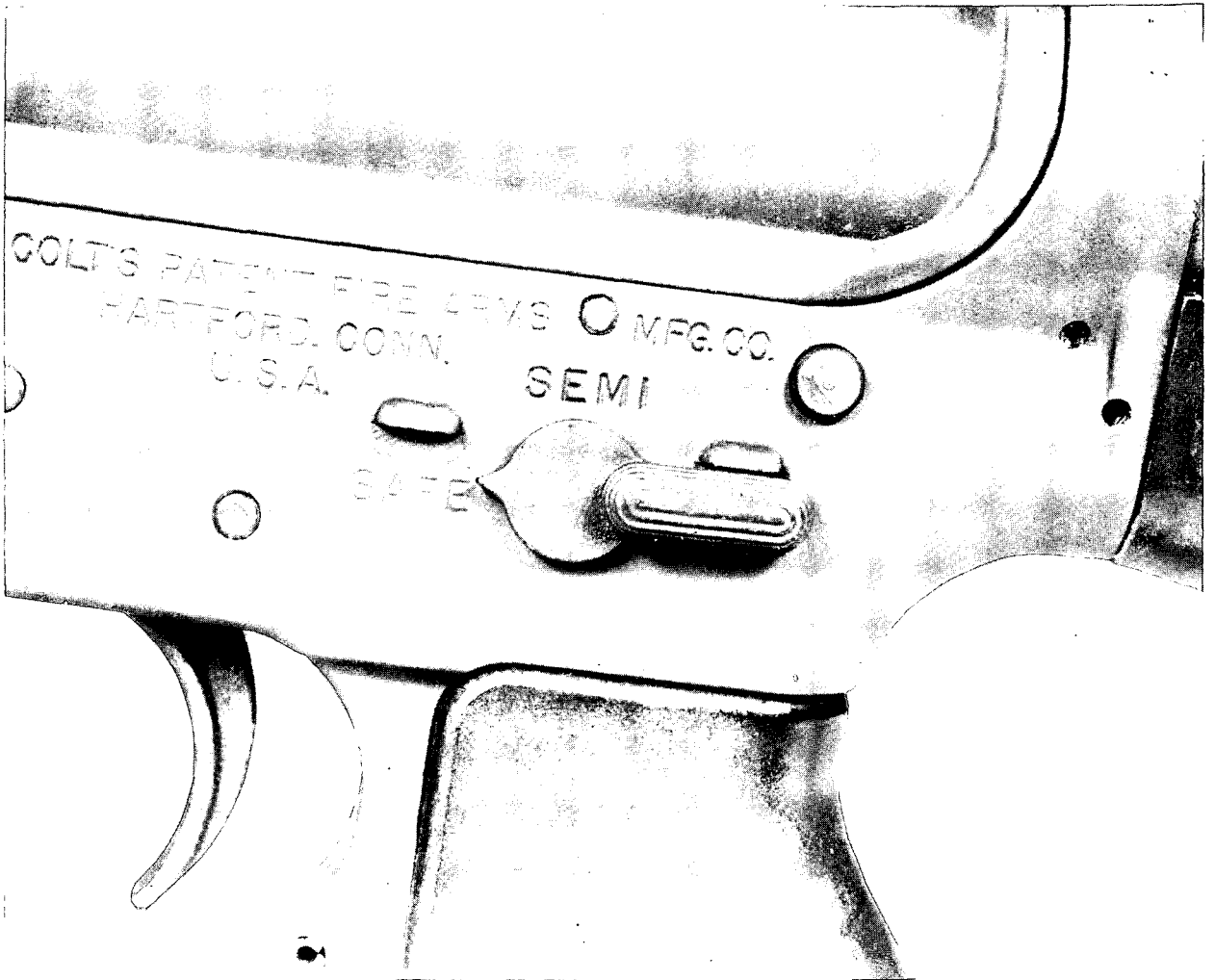

Figure 3. Selector lever pointing to SAFE.

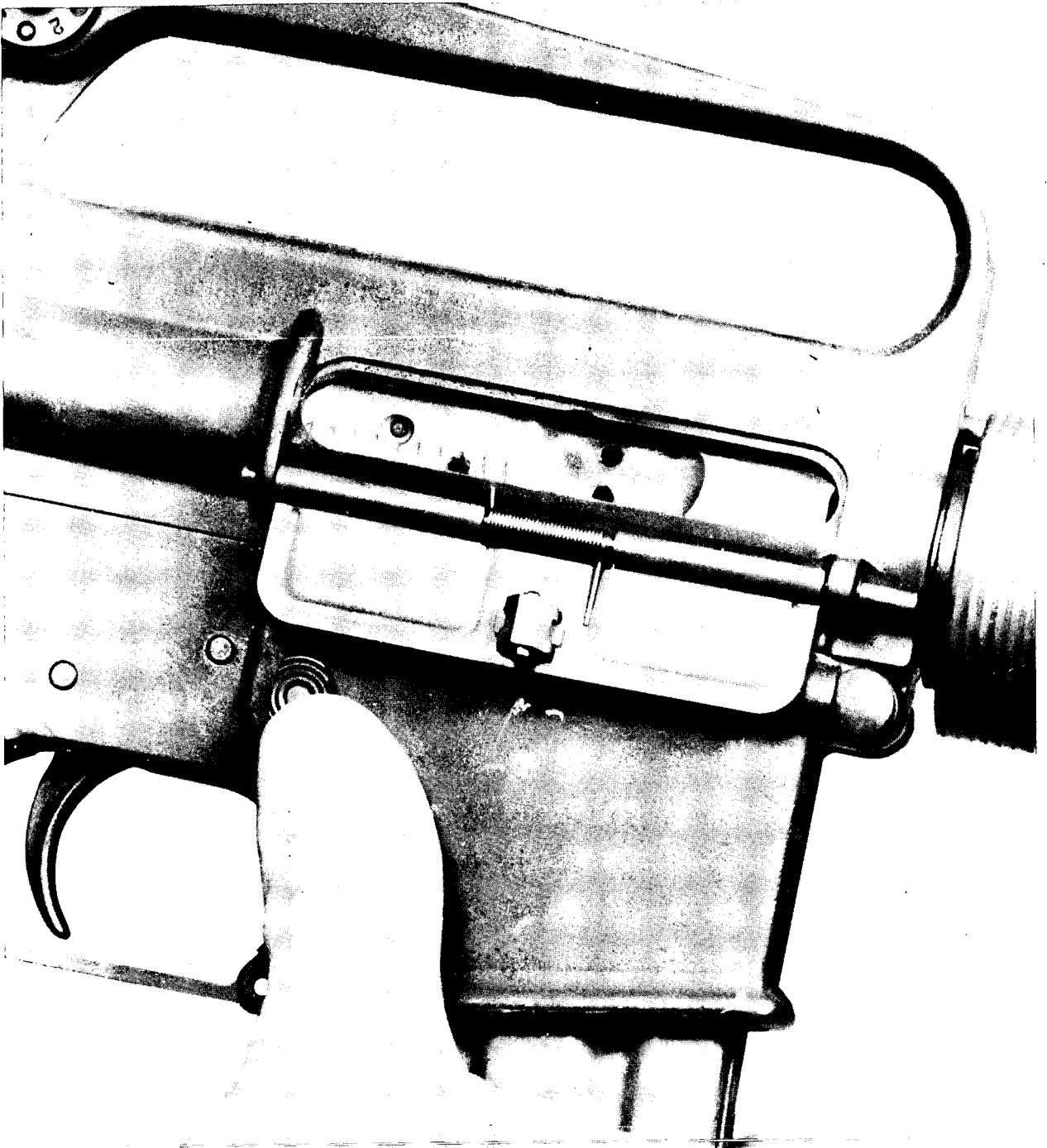

Figure 4. Removing the magazine.

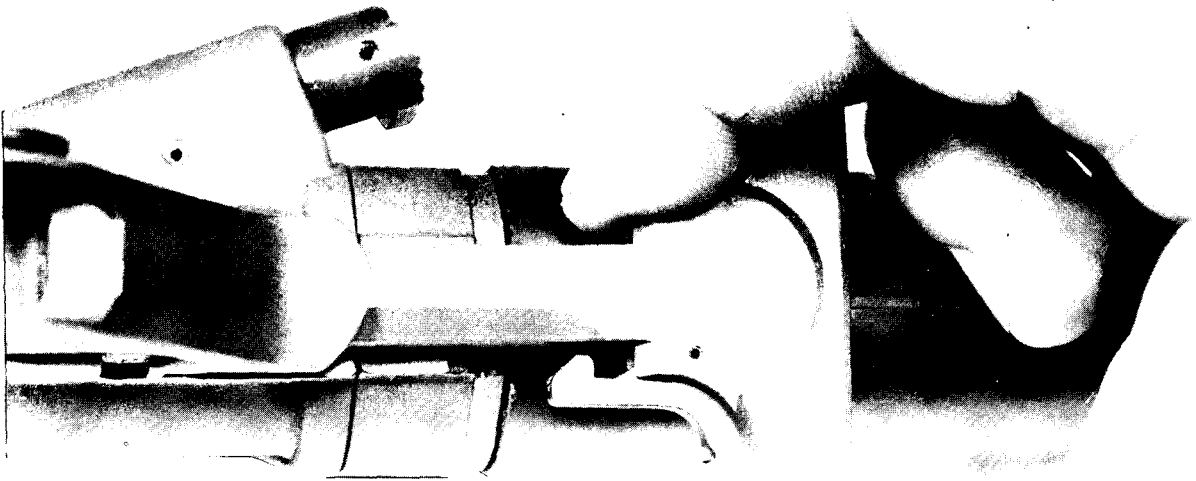

Figure 5. Pulling the charging handle rearward.



Figure 6. Locking the bolt open.

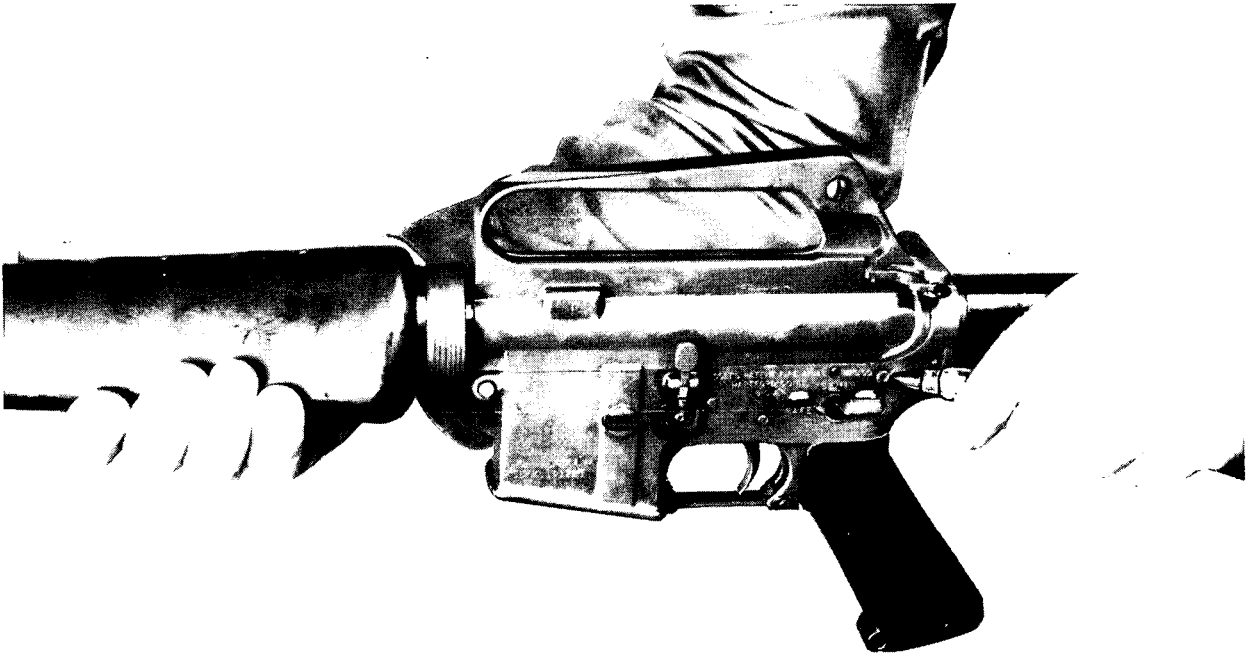

Figure 7. Pressing the takedown pin to the right.

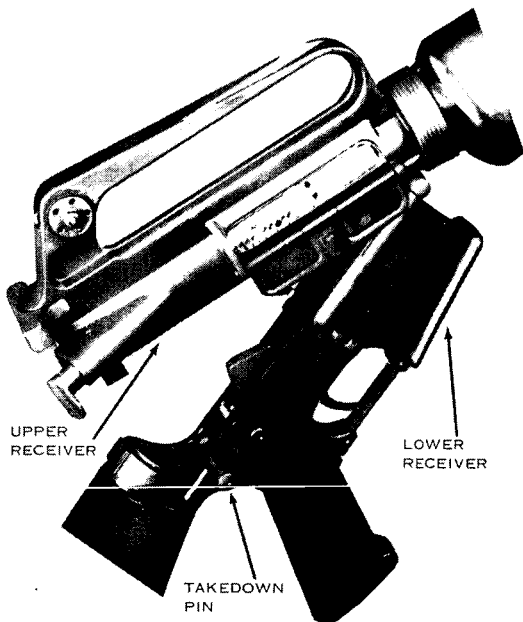

Figure 8. Breaking the upper receiver away from the lower receiver.

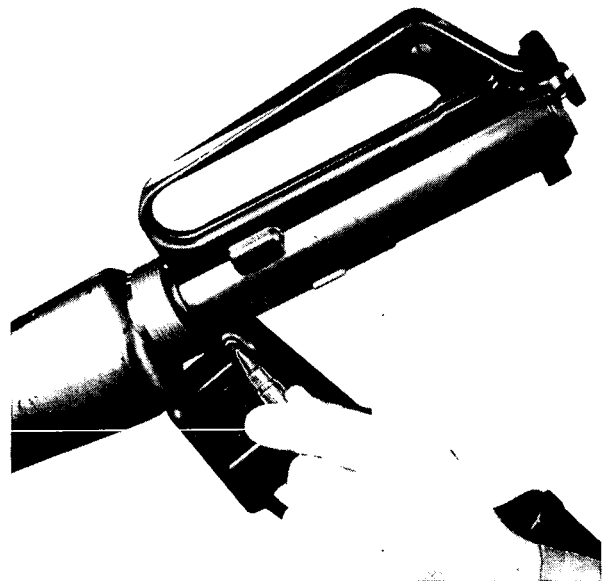

Figure 9. Pressing out the receiver pivot pin.

c. Again using the nose of a cartridge, press the receiver pivot pin (fig. 9). Separate the upper and lower receiver groups (fig. 10) and place the lower receiver group on the table.

Caution: The receiver pivot pin does not come out of the receiver.

d. Pick up the upper receiver group; keep the muzzle to the left. Grasp the charging handle, pressing in on the latch, and pull to the rear (fig. 5) to withdraw the bolt carrier from the receiver. Grasp the bolt carrier and pull it from the receiver (fig. 11). When the bolt carrier is removed, the charging handle will fall free of its groove in the receiver (fig. 12). Place the receiver on the table.

e. To disassemble the bolt carrier group, press out the firing pin retaining pin by using the nose of a cartridge (fig. 13). Elevate the front of the bolt carrier and allow the firing pin to drop from its well in the bolt (fig. 14). Rotate the bolt until the cam pin is clear of the bolt carrier key and remove the cam pin by rotating it 90 degrees ($\frac{1}{4}$ -turn) and lifting it out of the well in the bolt and bolt carrier (fig. 15). After the cam pin is removed, the bolt can be easily removed from its recess in the bolt carrier (fig. 16). This completes disassembly of the bolt carrier group. Further disassembly of the bolt is authorized by the company armorer.

Caution: Steps (f) and (g) below should be performed only when absolutely necessary for care and cleaning.

f. Using the index finger of the right hand, push in on the action spring guide assembly. With the nose of a cartridge or the tip of the firing pin, push down on the buffer retainer. Allow the action spring guide assembly to move forward slowly until clear of the buffer retainer. Depress the hammer to the rear (downward) sufficiently to allow the action spring guide assembly to clear the hammer. Remove the action spring guide assembly and the action spring (fig. 17).

Note. The action spring is under pressure and care must be taken in removing it.

g. The last parts to be removed are the handguards. Place the upper receiver on the table with the muzzle up. Pull down on the slipping until the lower lip of the handguard is clear; pull out and down on the handguard until the upper lip is free of the handguard cap (fig. 18). Repeat the same operation to remove the second handguard. Considerable pressure must be used to force the slipping down.

Note. Handguards should not be removed when the upper and lower receiver groups are separated because of potential damage to the forward assist assembly.

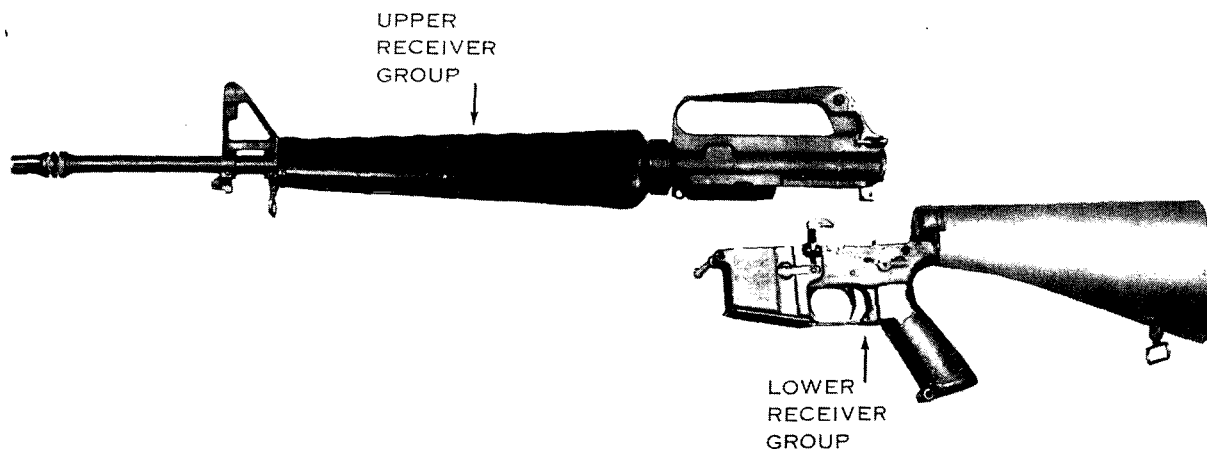

Figure 10. Upper and lower receiver groups.

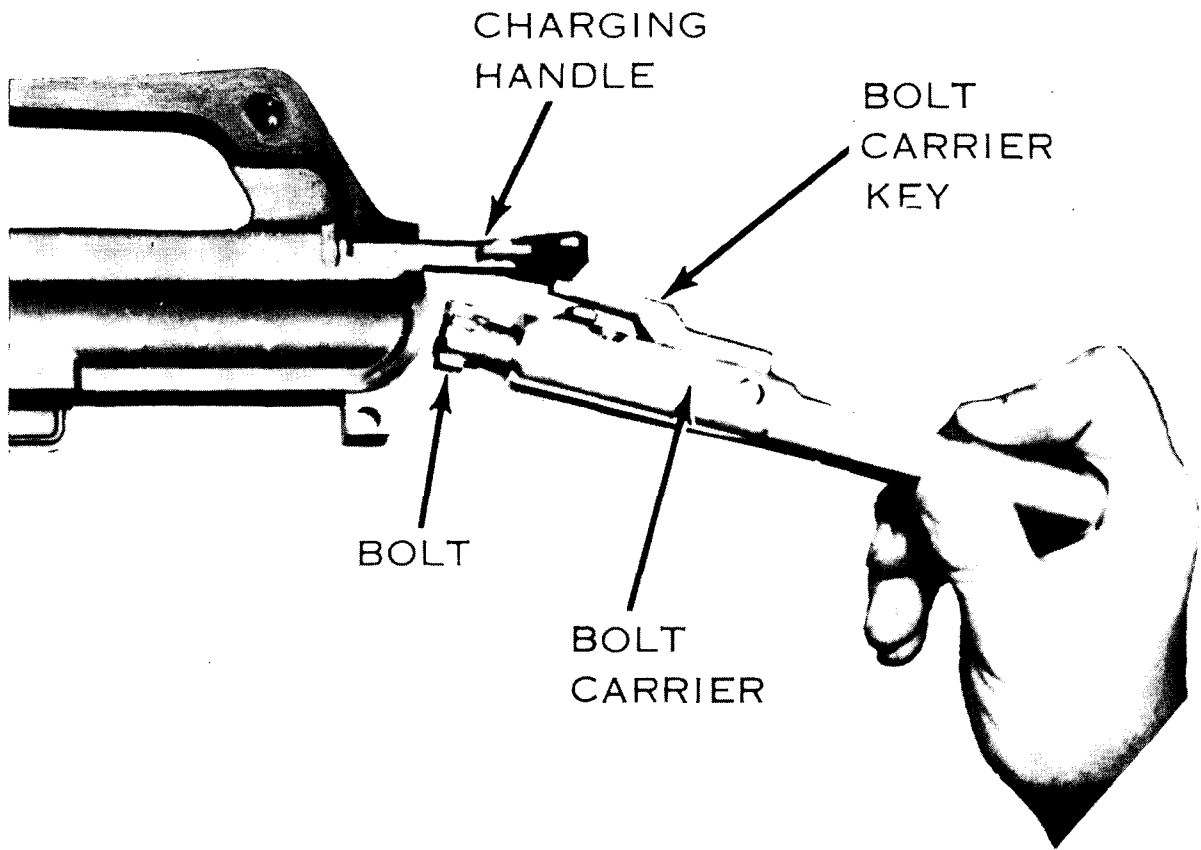

Figure 11. Removing bolt carrier from receiver.

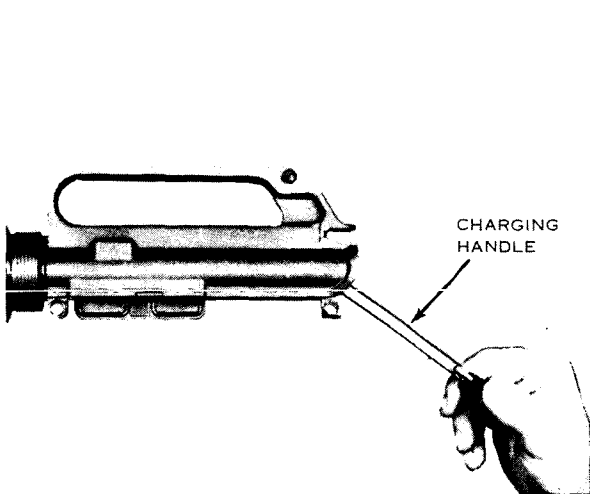

Figure 12. Removing the charging handle.

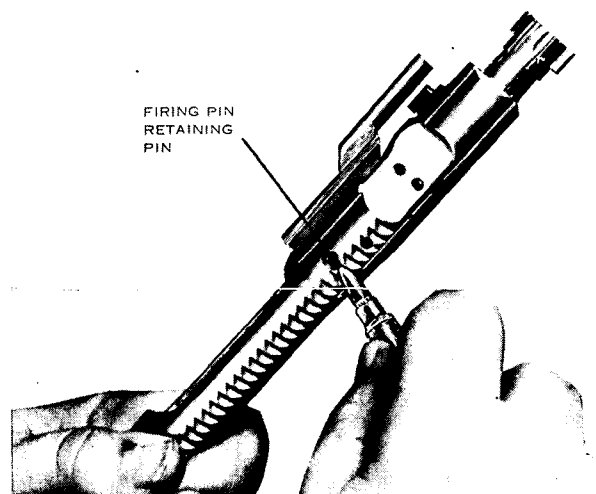

Figure 13. Pressing out firing pin retaining pin.

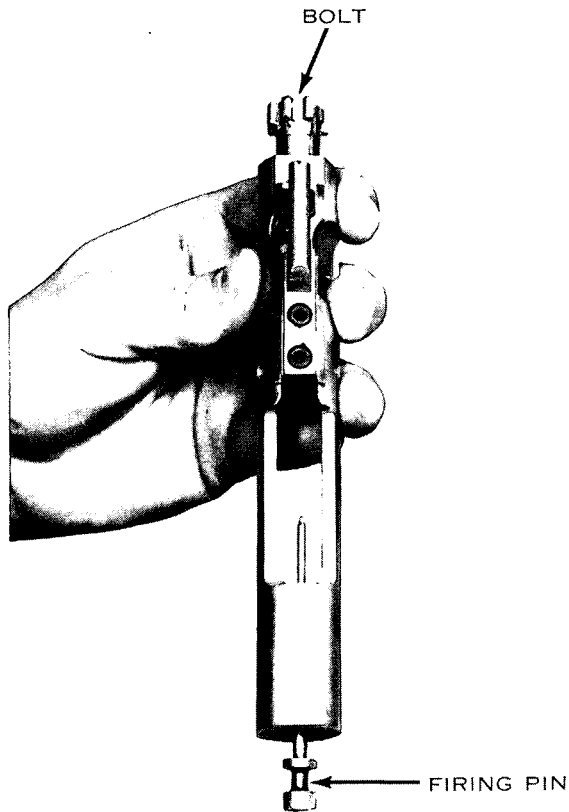

Figure 14. Removing the firing pin.

h. This completes field stripping (fig. 19).

Note. Detailed disassembly consists of removing the remaining operating parts from the lower receiver (fig. 20) and is *not* authorized at user and/or organization level. The individual soldier has no need to disassemble the weapon beyond field stripping. Only qualified maintenance personnel are authorized to remove any other parts from the weapon.

8. Assembly

To assemble the rifle, reverse the procedures of disassembly.

a. To assemble the bolt carrier group, grasp the bolt carrier, key up and to the front, inserting the bolt into the front of the bolt carrier, insuring that the ejector is down and to the left. Replace the cam pin into its well and rotate the cam pin 90 degrees ($\frac{1}{4}$ -turn) to align the holes in the bolt and cam pin. Grasp the lugged rim of the bolt and turn until the cam pin is directly beneath the bolt carrier key. Insert the firing pin through the open end of the bolt carrier and seat fully. Insert the firing pin retaining pin (if

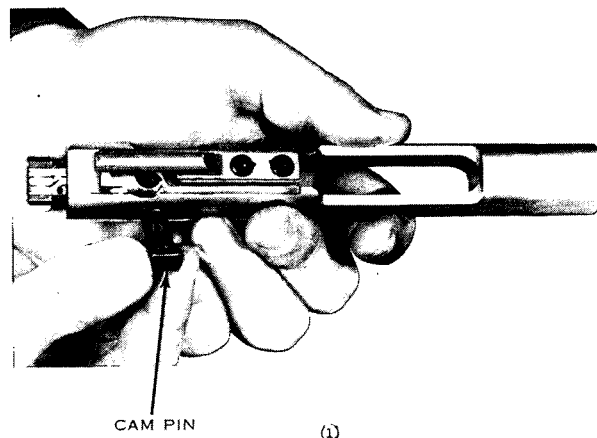

Figure 15. Removing the cam pin.

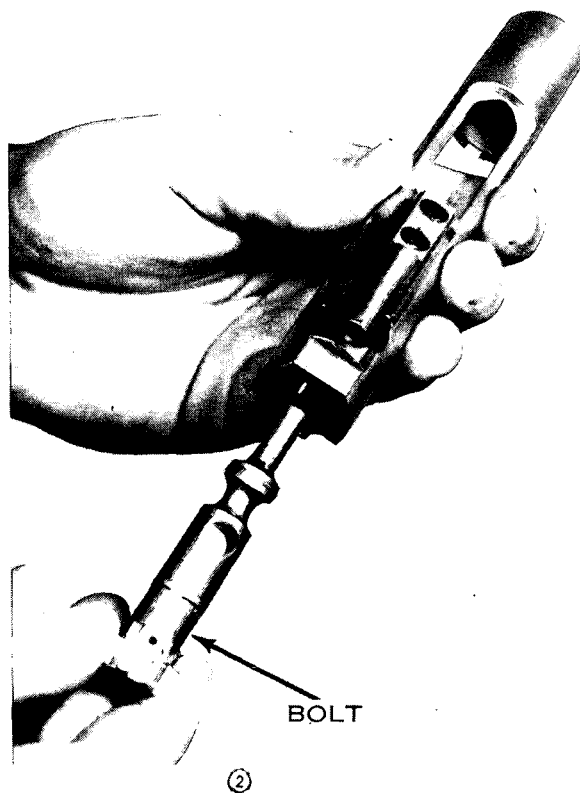

Figure 16. Removing the bolt.

resistance is encountered, rotate pin while inserting).

Caution: Do not attempt to spread the slotted end of the firing pin retaining pin.

Note. Check for proper assembly by elevating the front of the bolt. If the firing pin drops out, the firing

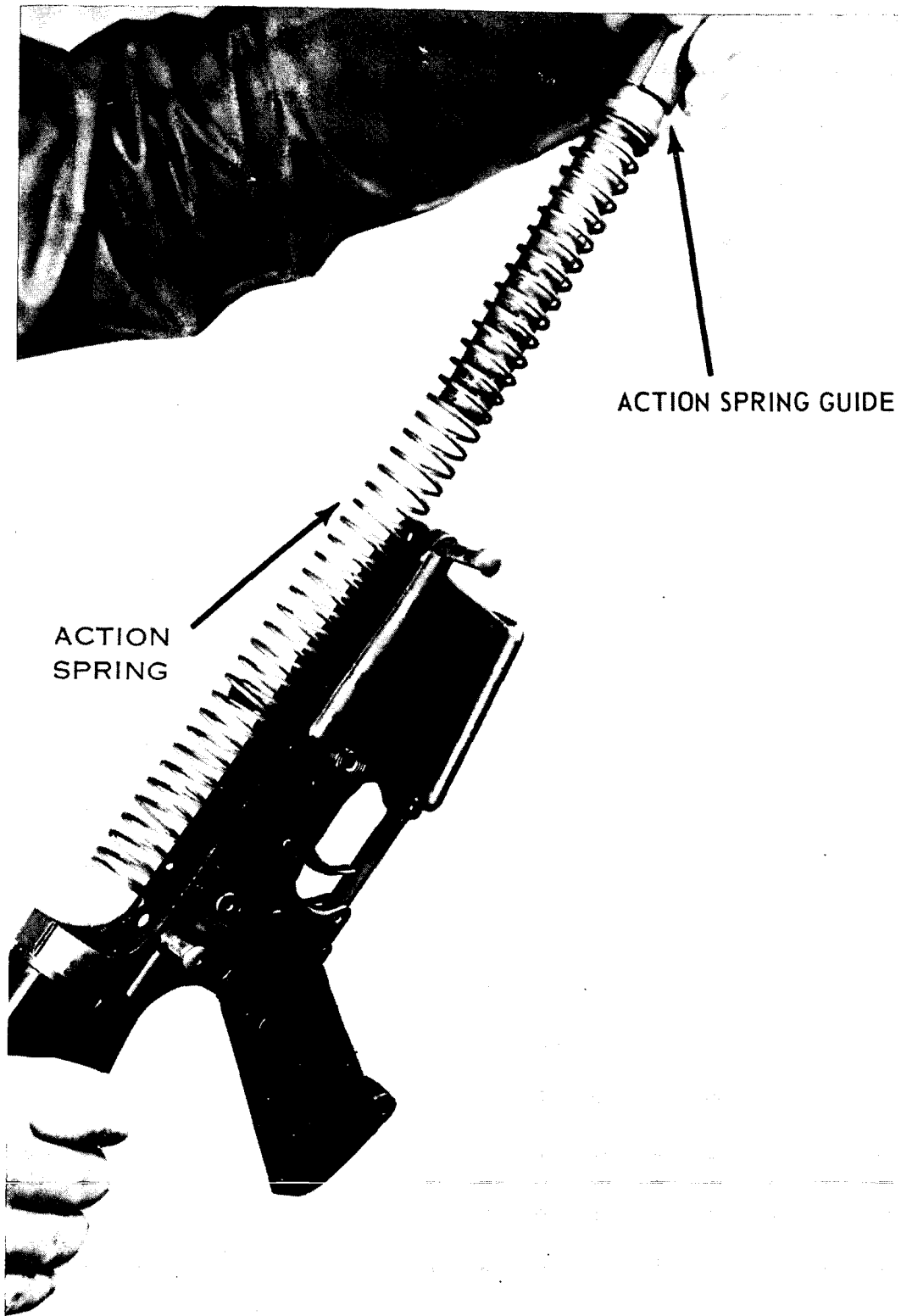

Figure 17. Removing the action spring guide assembly and action spring.

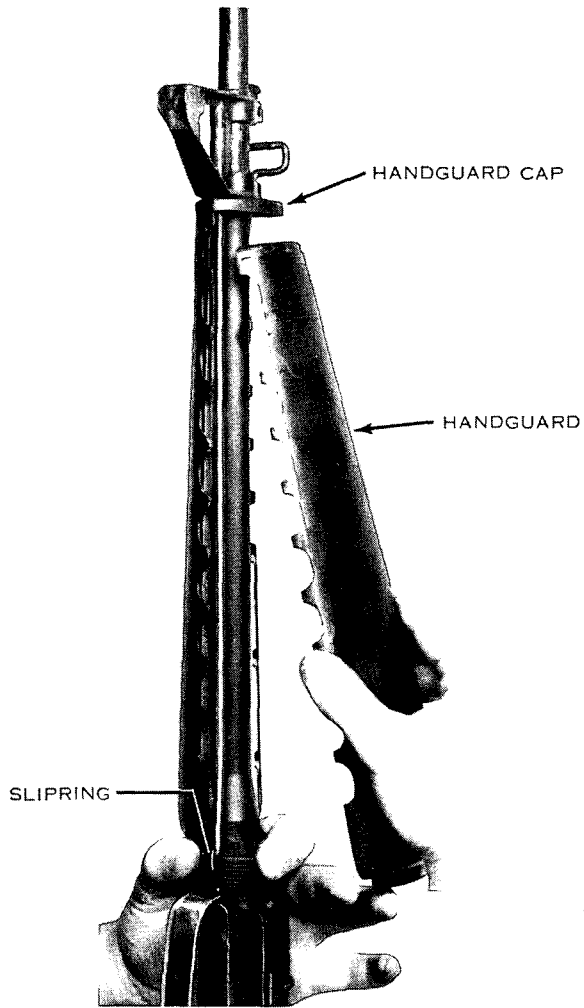

Figure 18. Removing the handguards.

pin retaining pin is not between the front and rear spool and the bolt carrier group is incorrectly assembled.

b. Replace the handguards and be sure that the slipring is fully seated on the lower lip of both sections of the handguard. Care must be taken to prevent damage to the upper and lower lips and to insure proper seating.

c. Grasp the upper receiver with the carrying handle up. Place the charging handle into the groove in the top of the upper receiver. The lugs on the charging handle must be seated in their grooves in the receiver. Place the bolt carrier group into the open end of the receiver, insuring that the bolt carrier key is in the slot on the underside of the charging handle and the bolt is forward in the unlocked position. Push forward on the bolt carrier group and charging handle until fully seated.

d. Place the upper receiver group and lower receiver group together and reseal the receiver pivot pin.

e. Insert the action spring guide assembly into the action spring and push the open end of the spring into the well in the receiver extension until the buffer retainer snaps into position.

f. Cock the hammer and put the selector lever on the safe position. Withdraw the takedown pin

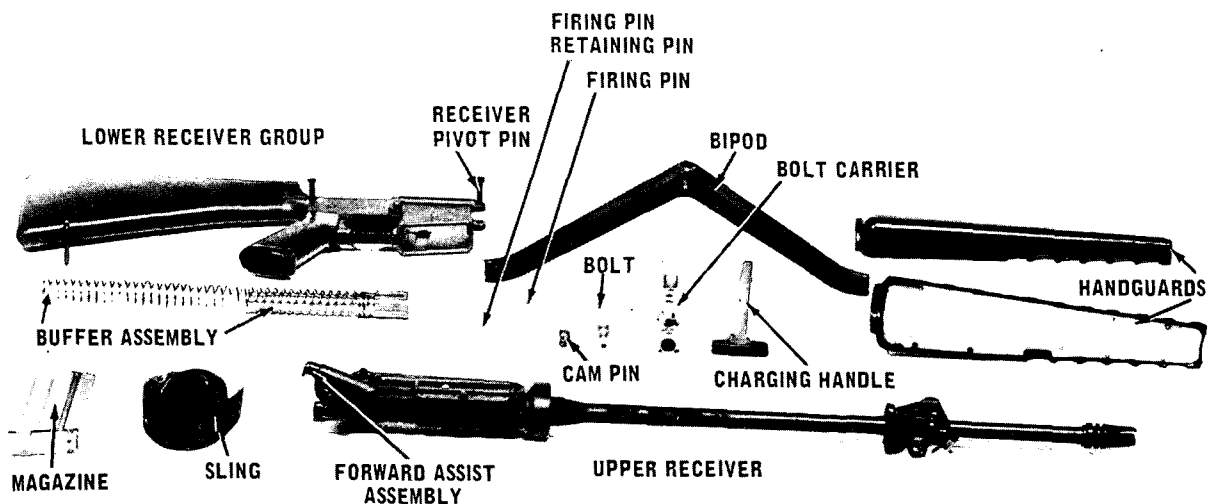

Figure 19. The XM16E1 field stripped.



Figure 20. Lower receiver group.

and close the weapon. Fully seat the takedown pin and replace the sling.

g. A complete function check of the rifle consists of checking the operation of the rifle while the selector is in the *SAFE*, *SEMI*, and *AUTO* positions. The following sequence is used for a rapid, complete check. Any portion of the check may be used alone to determine the operational condition of any specific fire selection. Start with the upper and lower receiver groups in the open position, the hammer cocked, and the magazine out.

- (1) *SAFE position.* Pull trigger. Hammer should not fall.
- (2) *SEMI position.* Pull trigger. The hammer should fall. Hold trigger to rear, recock hammer and release trigger. Hammer should transfer from hammer hooks and disconnect to the hammer and sear engagement.
- (3) *AUTO position.* Pull trigger. Hammer should fall. Hold trigger to the rear and recock the hammer. Still holding the trigger to the rear, push forward on the automatic sear. The hammer should fall.

Section II. OPERATION AND FUNCTIONING

9. Operation

a. Loading the Magazine.

- (1) The magazine has a capacity of 20 rounds and may be loaded with any amount up to that capacity. The magazine follower has a raised portion generally resembling the outline of a cartridge.
- (2) Cartridges are loaded into the magazine so that the tips of the bullets point in the same direction as the raised portion of the follower (fig. 21).

b. Loading the Rifle.

- (1) With the hammer cocked, place the selector lever on *SAFE* (fig. 3). The magazine may be inserted with the bolt opened or closed. However, the soldier should be taught to load the weapon with the bolt open. This will reduce the possibilities of a first-round stoppage and save the time needed to pull the charging handle to the rear.
 - (2) Hold the stock of the rifle under the right arm with the right hand grasping the pistol grip, and point the muzzle in a safe direction. With the left hand, insert a loaded magazine into the magazine feedway. Push upward until the magazine catch engages and holds the magazine. Rap the base of magazine sharply with the heel of the hand to insure positive retention. Depress the upper portion of the bolt catch (fig. 22) with the thumb of the left hand, allowing the bolt to close, chambering a round. If the bolt is closed when the magazine is inserted, pull the charging handle fully to the rear with the right hand and release it.
- Note.* Do not "ride" the charging handle forward with the right hand. If the charging handle is eased forward from the open position, the bolt may fail to lock. If the bolt fails to go fully forward, use the forward assist assembly (fig. 1). To operate, strike the forward assist with the heel of the right hand.
- (3) The bolt catch will hold the bolt carrier to the rear after the last round is fired. To change magazines for reloading, press the magazine catch button and re-



Figure 21. Loading cartridges into the magazine.

move the empty magazine from the weapon. Place the new magazine into the magazine feedway and push up until fully seated (9b(2)).

c. Unloading. To unload the rifle and make it safe, the firer first places the selector lever on safe, presses the magazine catch button and removes the magazine, pulls the charging handle to the rear, inspects the chamber to insure it is clear, locks the bolt carrier to the rear by depressing the lower portion of the bolt catch, and returns the charging handle forward. The rifle is clear *only* when no round is in the chamber, the magazine is out, the bolt carrier is to the rear, and the selector lever is on the *SAFE* setting.

10. Functioning

a. Functioning consists of eight basic steps. Keep in mind that more than one of these steps takes place at a time. The eight steps are:

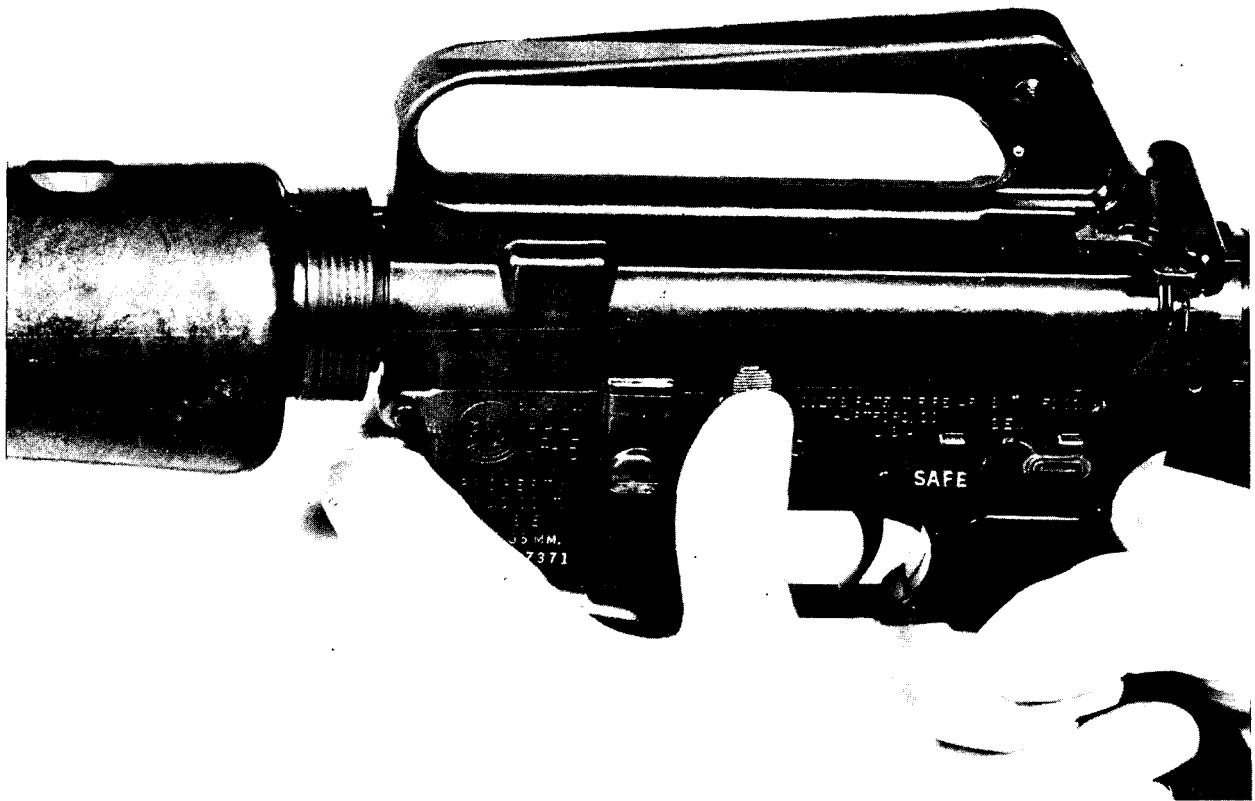

Figure 22. Depressing the upper portion of the bolt catch.

- (1) Firing.
- (2) Unlocking.
- (3) Extracting.
- (4) Ejecting.
- (5) Cocking.
- (6) Feeding.
- (7) Chambering.
- (8) Locking.

b. Functioning in the rifle may be either automatic or semiautomatic through the use of the selector lever. Certain differences in the operation of parts take place when the selection is made.

(1) *Semiautomatic fire.*

- (a) *Firing.* With a round in the chamber, the hammer cocked and the selector on the SEMI setting, the firer pulls the trigger. The trigger rotates on the trigger pin depressing the nose of the

trigger and disengaging the notch on the bottom of the hammer. The hammer is thrown forward by action of the hammer spring. The hammer strikes the head of the firing pin, driving the firing pin through the bolt into the primer of the round. The action of the rifle is so much faster than human reaction that it is impossible for the firer to release the trigger rapidly enough to prevent multiple firing. Therefore, it is necessary for a mechanism to be installed in the weapon to enable the firer to fire single rounds. In the XM16E1 the disconnect is used for this purpose. The disconnect is attached to the trigger and is rotated forward by action of the disconnect spring. When the hammer is cocked by the recoil of the bolt carrier, the disconnect engages the lower hook of

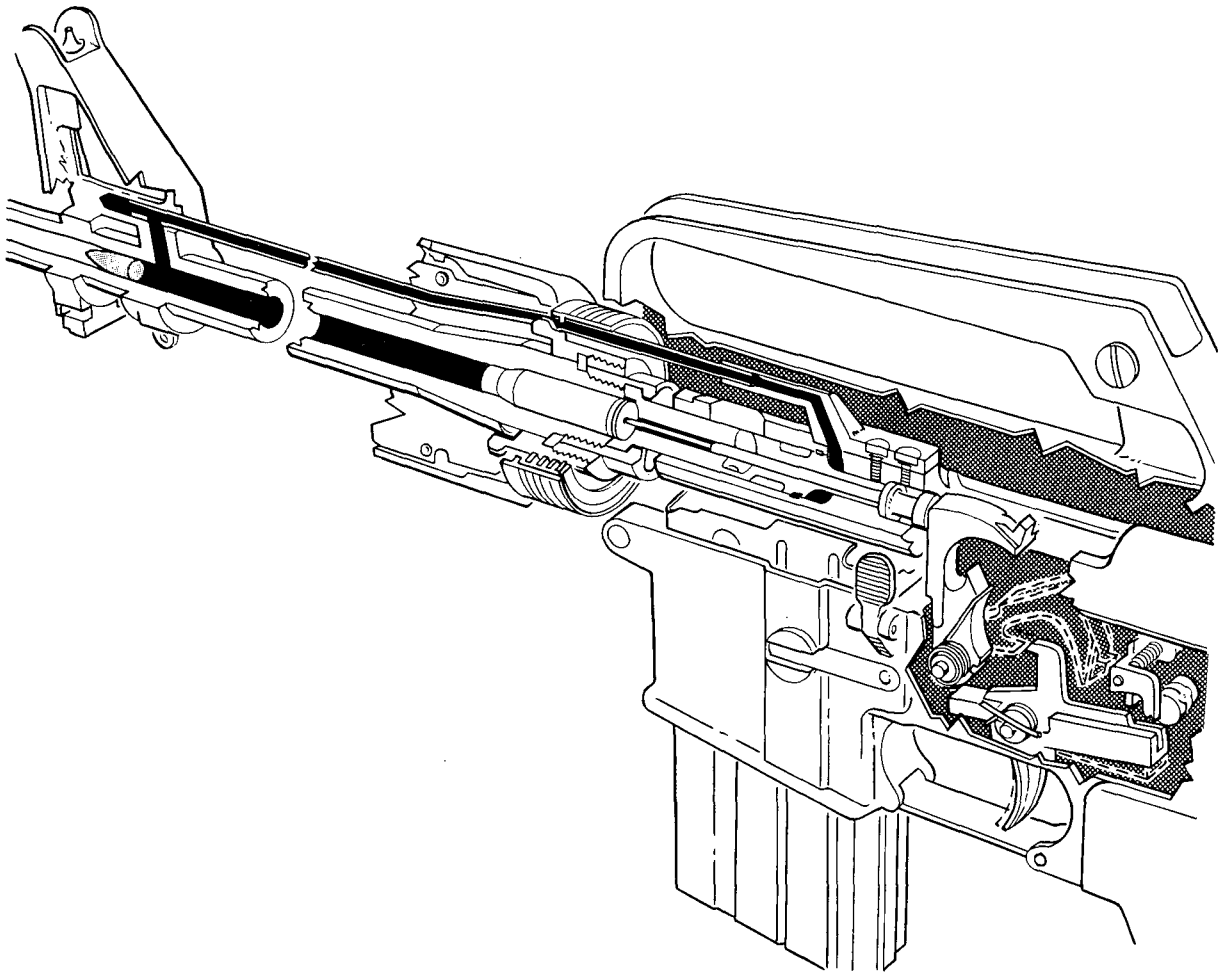

Figure 23. Firing.

the hammer and holds it until the trigger is released. When the trigger is released, the disconnect rotates to the rear and down, disengaging the hammer and allowing it to rotate forward until caught by the nose of the trigger. This prevents the hammer from following the bolt carrier forward and causing automatic fire (fig. 23).

- (b) *Action of the gas.* When the primer ignites the powder, the projectile is forced through the barrel. At the same time the gas moves through the barrel until, passing the gas port located on the upper surface of the barrel (under the front sight), a small portion of the gas passes through the gas port and into the gas tube (fig. 24). The gas tube directs the gas into the cylin-

der between the bolt and bolt carrier, causing the bolt carrier to move rearward.

- (c) *Unlocking.* As the bolt carrier moves to the rear, the cam track in its upper surface acts on the bolt cam pin, rotating the cam pin and bolt until the locking lugs of the bolt are no longer in line with the locking lugs of the barrel extension (fig. 25).
- (d) *Extracting.* The bolt carrier continues to the rear, carrying with it the bolt. By means of the extractor, which is attached to the bolt, the expended cartridge is withdrawn from the chamber. The claw of the extractor is gripping the rim of the cartridge, holding the base of the round against the face of the bolt (fig. 26).

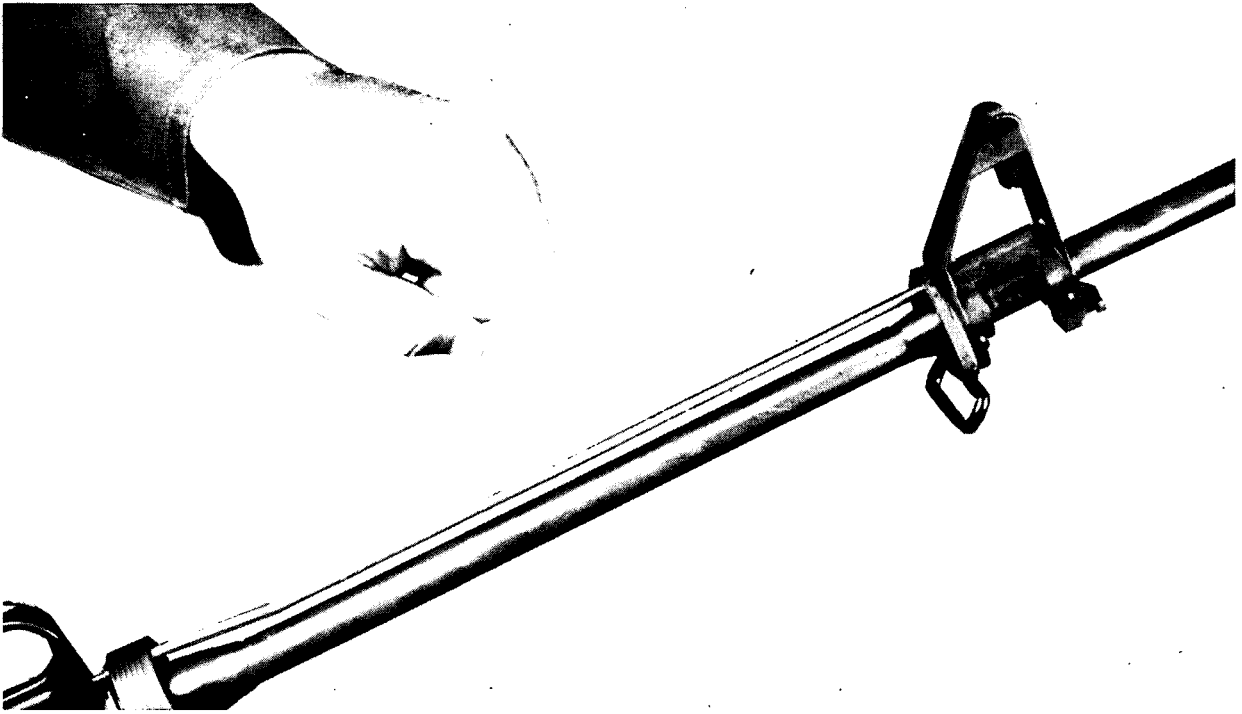

Figure 24. Gas tube.

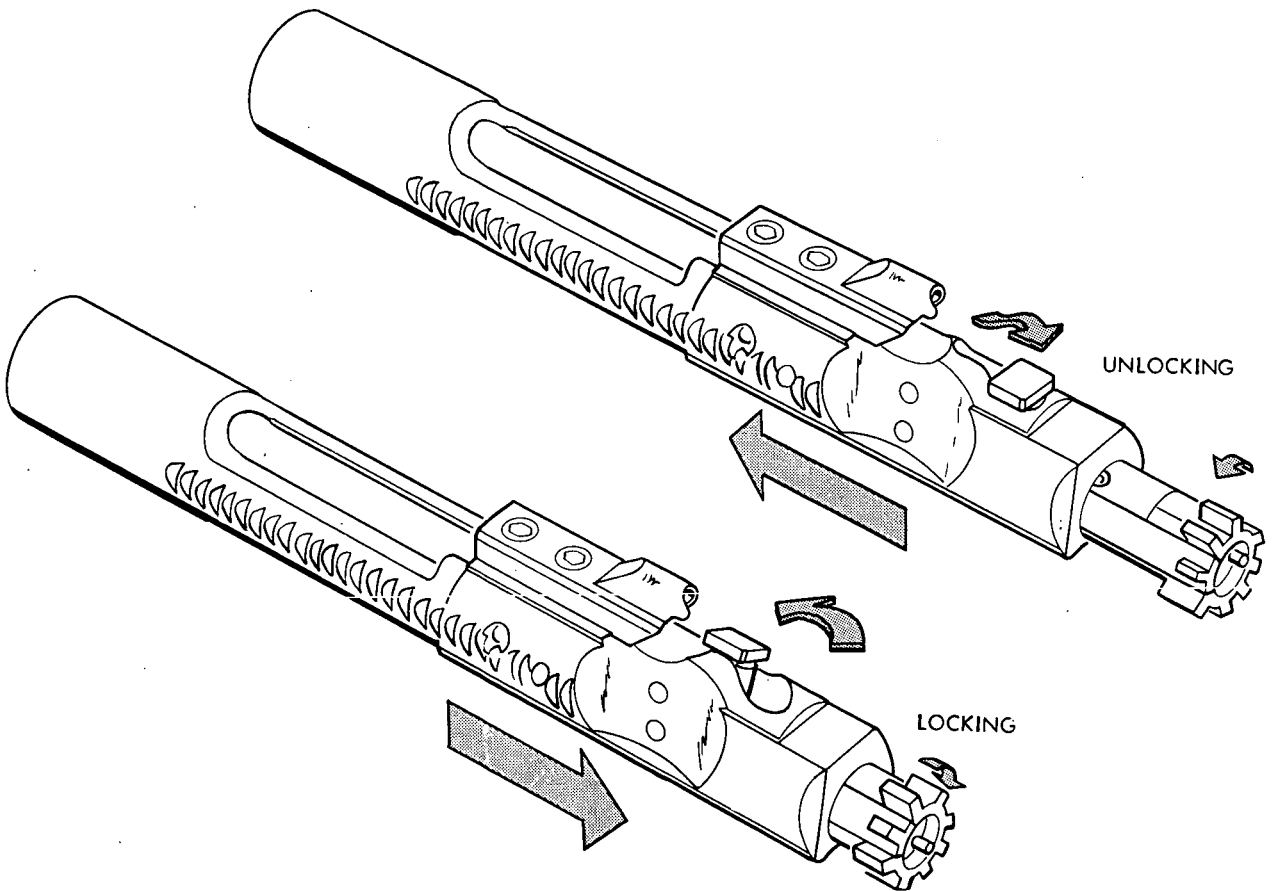

Figure 25. Locking and unlocking.

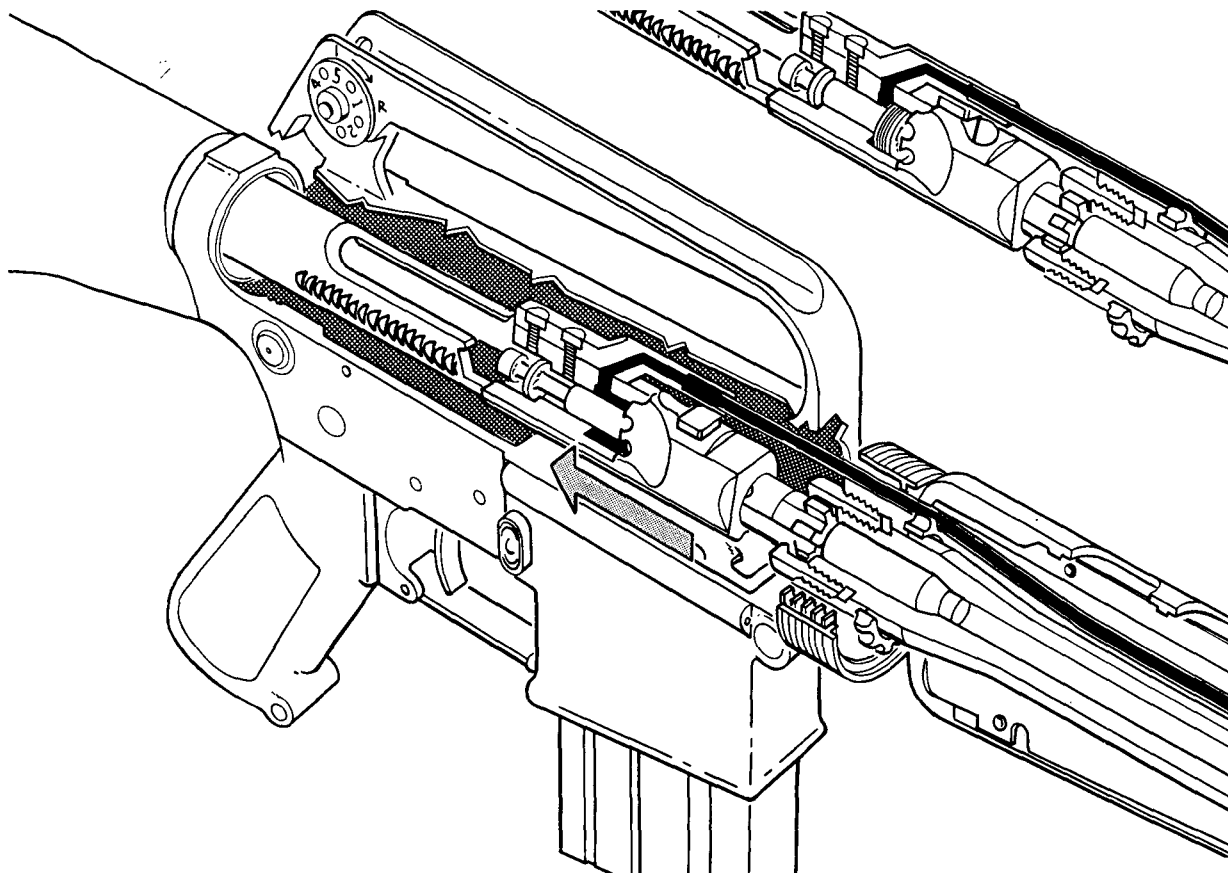

Figure 26. *Extracting.*

- (e) *Ejecting.* When the base of the round is against the face of the bolt, the ejector is compressed. As the bolt carrier clears the ejection port, the empty cartridge is thrown out by action of the ejector and spring (fig. 27).
- (f) *Cocking.* The rearward movement of the bolt carrier overrides the hammer, forcing it down into the receiver, compressing the hammer spring. The lower hook of the hammer is engaged by the disconnect. When the trigger is released the hammer slips from the disconnect and is caught by the nose of the trigger. The trigger must be pulled again before the next round will fire (fig. 28).
- (g) *Feeding.* As the bolt carrier group clears the top of the magazine, the follower and spring in the magazine push a new round up into the path of the bolt (fig. 29).
- (h) *Action of the buffer assembly.* As the bolt carrier group is moving rearward, the head of the action spring guide assembly is struck. This sends the action spring guide assembly and action spring rearward into the receiver extension. The expansion of the action spring sends the action spring guide assembly forward with enough force to drive the bolt carrier group forward toward the chamber. The buffer assembly is designed to reduce the recoil of the weapon.
- (i) *Chambering.* On the forward stroke of the bolt carrier group, the face of the bolt strips a round from the magazine and thrusts it into the chamber. At the same time the extractor claw grips the rim of the cartridge and the ejector is compressed (fig. 30).
- (j) *Locking.* When the bolt carrier group enters the last half inch of its forward

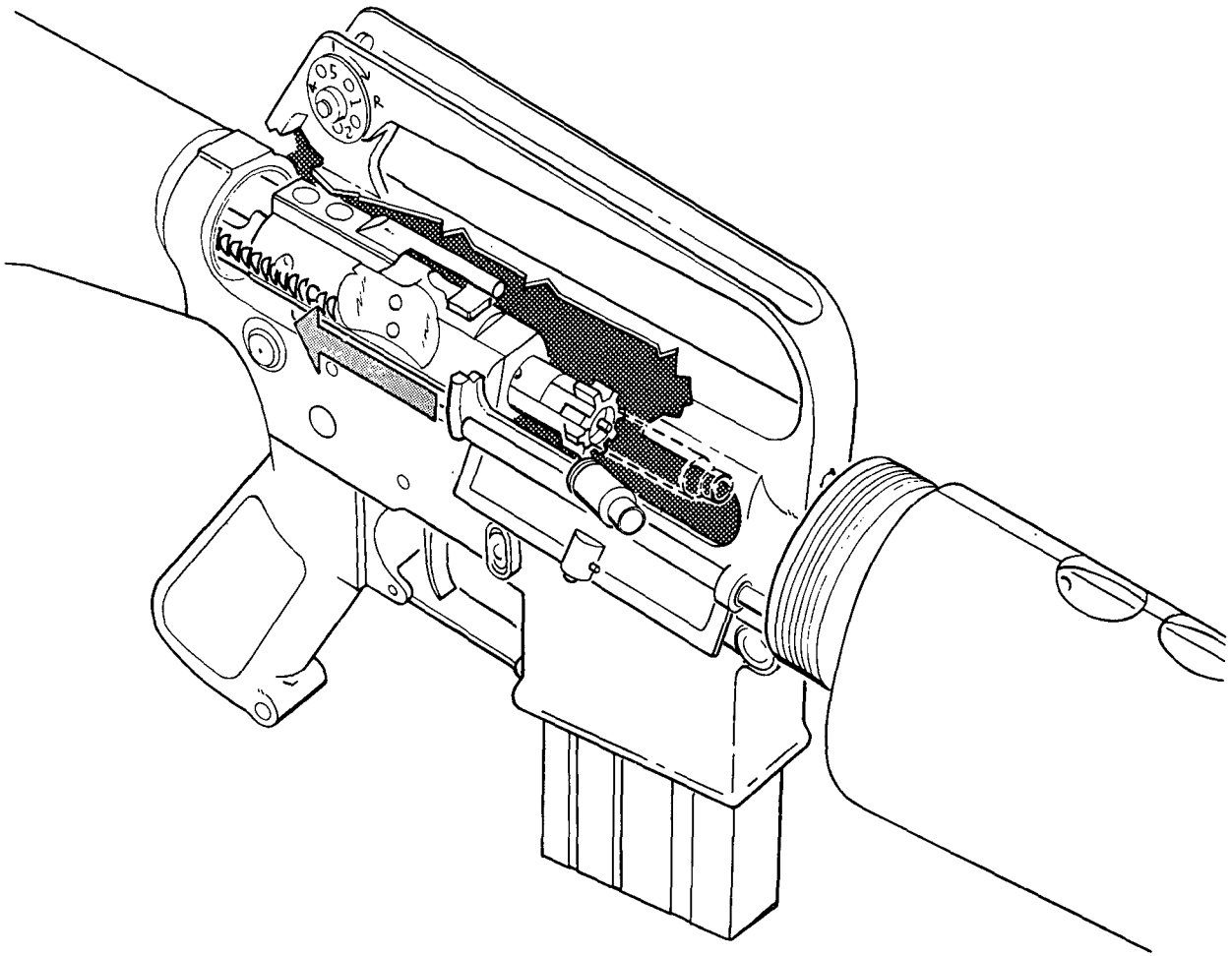

Figure 27. Ejecting.

movement, the bolt cam pin emerges from the guide channel in the upper receiver and moves along the cam track, rotating the bolt *counterclockwise* into the locked position (fig. 25). The weapon is then ready to fire and the cycle begins again.

(2) *Automatic fire.*

- (a) When the selector lever is set on the AUTO position, the rifle will continue fire as long as the trigger is held back and ammunition is in the magazine. The functioning of certain parts of the weapon changes when firing automatic.
- (b) As the rifleman pulls the trigger, the

cycle of operation begins. As the bolt carrier group recoils the hammer is cocked, but the center cam of the selector prevents the disconnect from engaging the hammer (fig. 31).

- (c) The automatic sear catches the upper hook of the hammer and holds it until the bolt carrier group moves forward striking the top of the sear, releasing the hammer, and causing the rifle to fire automatically (fig. 32).
- (d) If the trigger is released the hammer moves forward and is caught by the nose of the trigger. This ends the automatic cycle of fire until the trigger is pulled again.

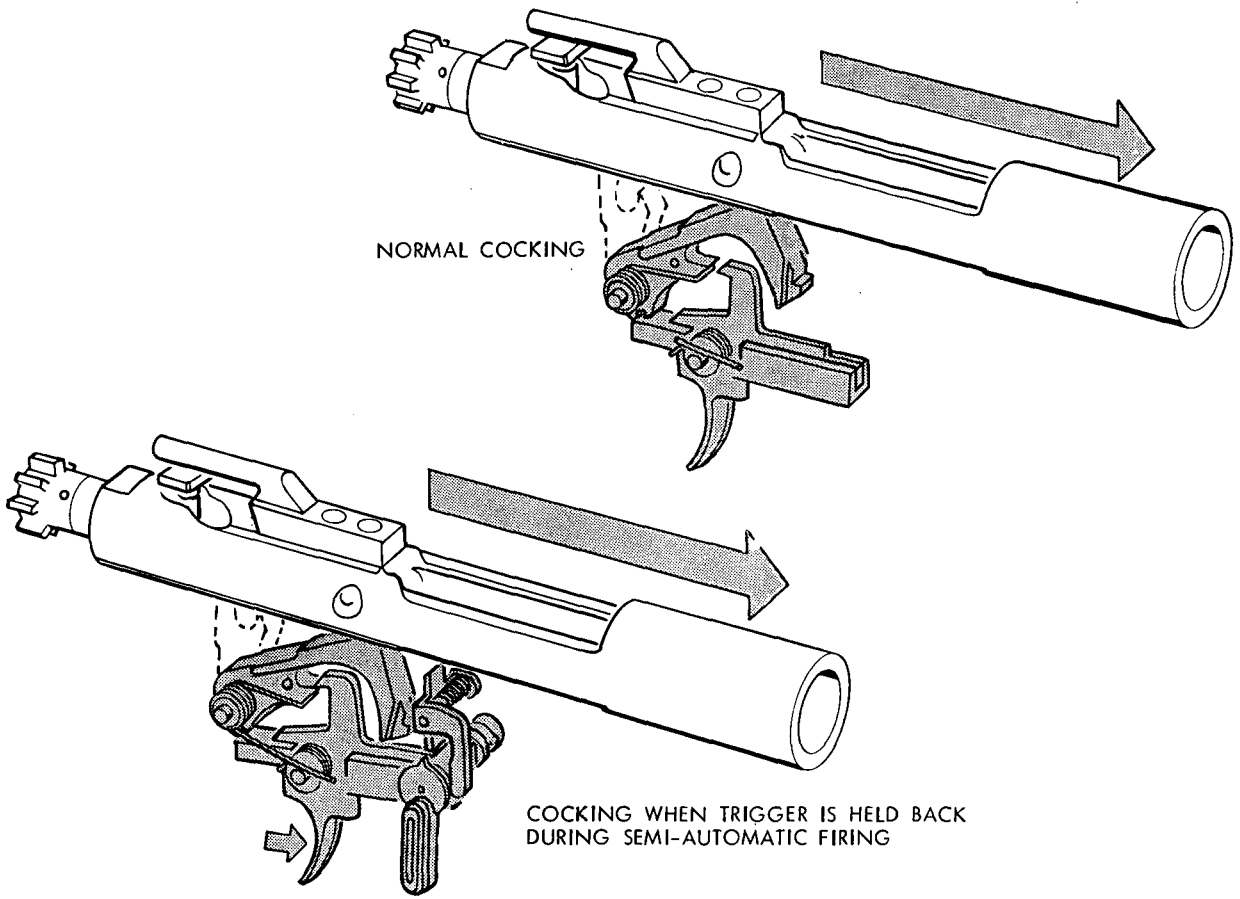

Figure 28. Cocking.

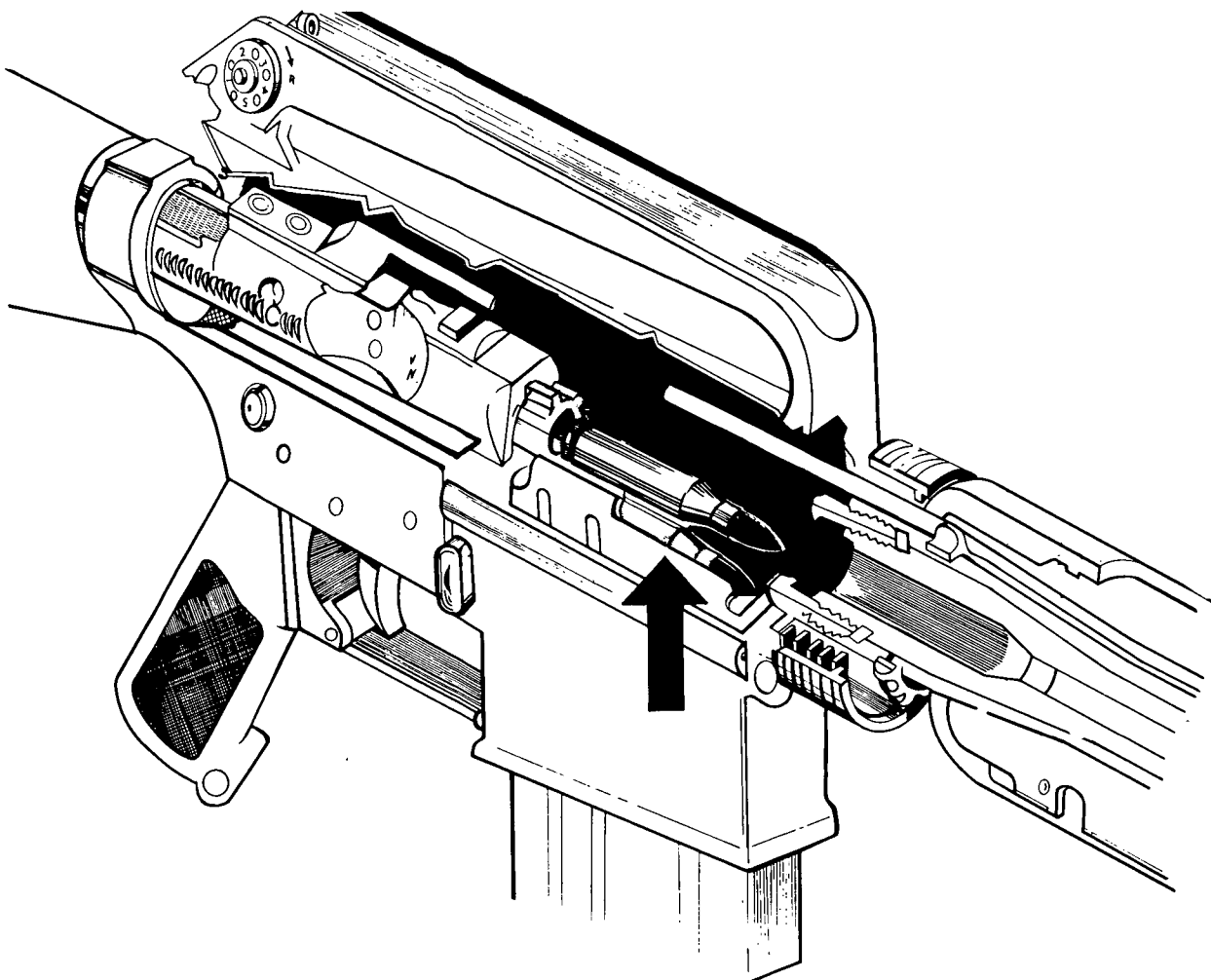

Figure 29. Feeding.

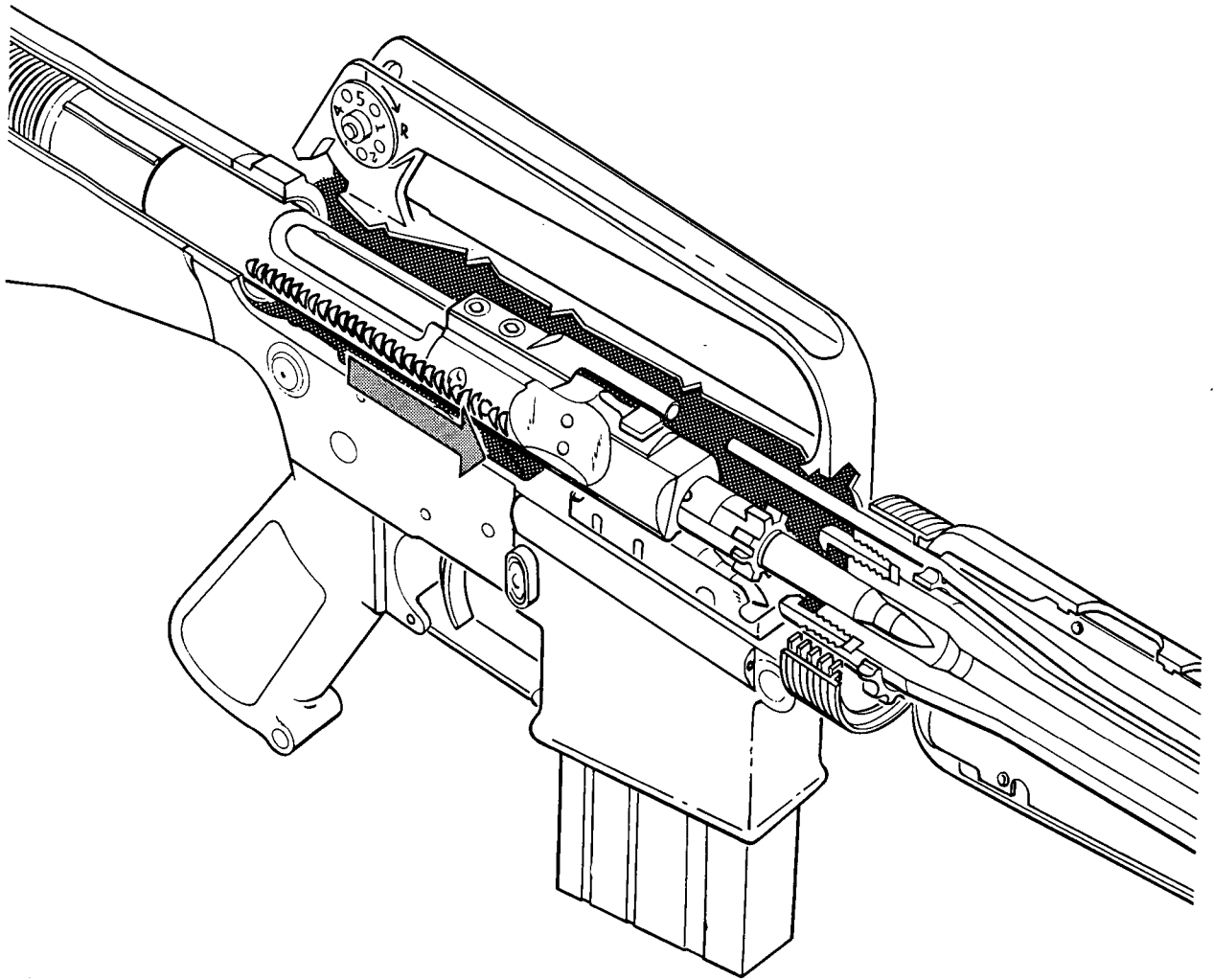

Figure 30. Chambering.

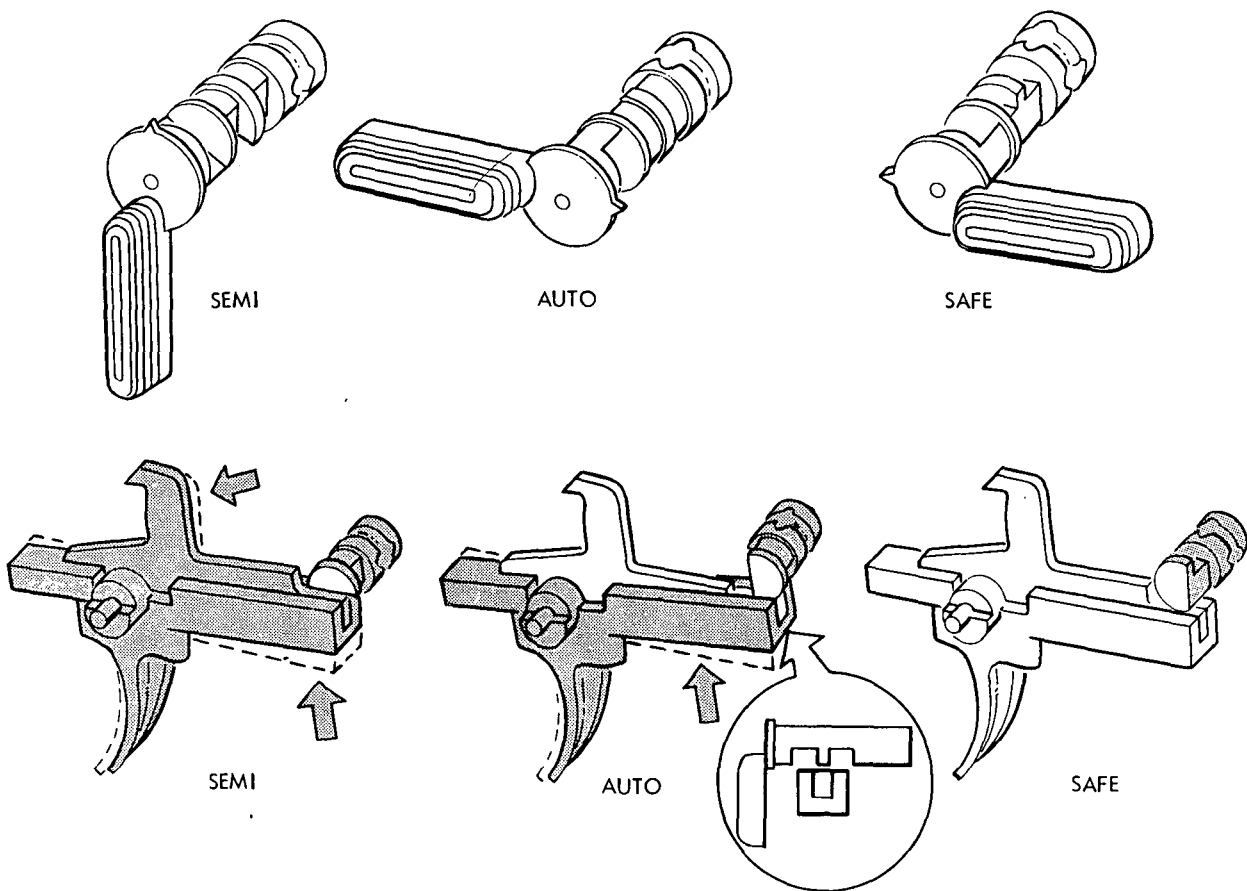

Figure 31. Selector lever.

(e) All other portions of the cycle of operation remain the same as in semi-automatic fire.

c. The functioning of the rifle through the cycle of operation stops when the trigger is released or when the magazine is empty. In the latter case certain actions take place within the weapon to tell the firer that he must change magazines.

- (1) When the last round of a magazine has been chambered, the magazine follower rises to the top of the magazine and contacts the bolt stop. As the bolt carrier group recoils after the last round is fired, the bolt stop is forced into the path

of the bolt face by action of the magazine spring. This holds the bolt carrier group to the rear.

- (2) Removal of the magazine does not release the bolt carrier group due to the force of the action spring holding the face of the bolt tightly against the catch. To release the bolt carrier group, the firer must press the head of the bolt catch located on the left side of the receiver.

Caution: If a new magazine has been inserted and the bolt carrier group goes forward, the weapon is charged and ready to fire.

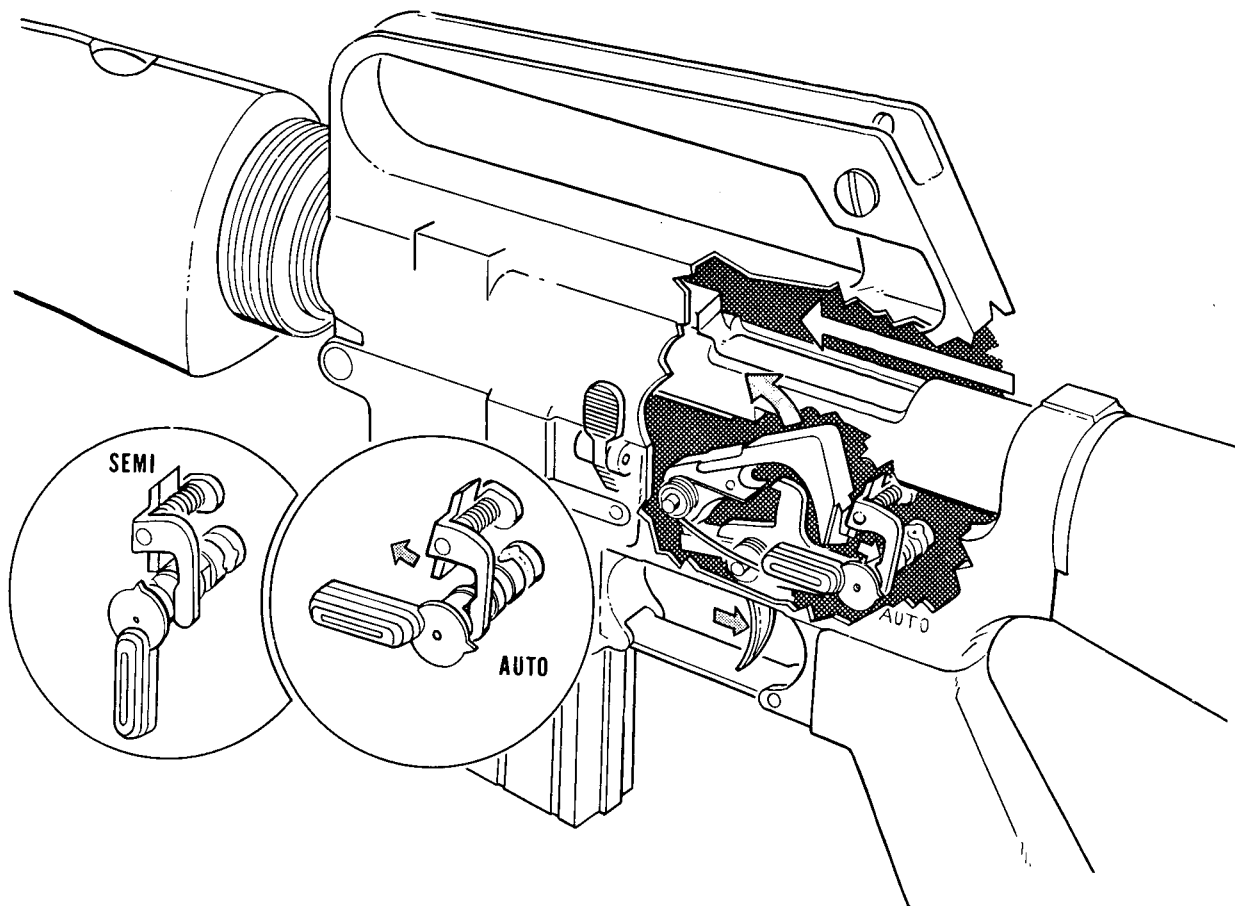

Figure 32. Automatic sear.

Section III. CARE AND CLEANING

11. Maintenance

Normal care and cleaning will result in proper functioning of all parts of the weapon. Improper maintenance causes stoppages and malfunctions. Only issue-type cleaning materials (fig. 33) as authorized in TM 9-1005-249-14 should be utilized. Cleaning materials are carried by the rifleman in the section provided on the bipod case.

a. *Cleaning and Lubricating the Barrel.*

- (1) Attach a wire brush to the cleaning rod, dip it in solvent cleaning compound (bore cleaner), and brush the bore thoroughly. Brush from the chamber to the muzzle using straight-through strokes (fig. 34). Push the brush through the bore until it extends beyond the muzzle. Continue this process until the bore is coated with compound. (Never reverse

the direction of the brush while in the bore.) Remove the brush from the cleaning rod and dry the bore with clear patches. The patches are to be cut into four equal size swabs. No more than one swab will be used at one time in the bore. Do not attempt to retract the rod until the swab has been removed (after going through the flash suppressor).

Caution: Cleaning rod is to be supported by hand, a section at a time, to prevent flexing and damage to the rod when starting into the bore.

- (2) Clean the locking lugs in the barrel extension, using a small bristle brush.
- (3) Clean the protruding exterior of the gas tube in the receiver with the bore brush attached to a section of the cleaning rod.

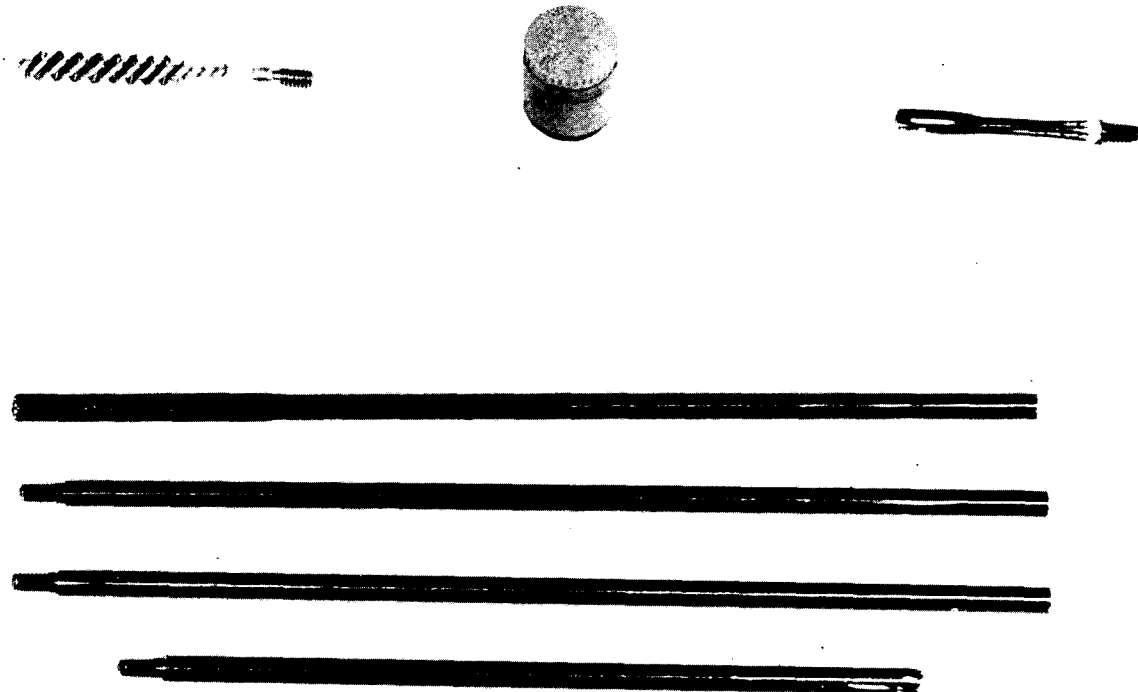

Figure 33. Cleaning equipment.

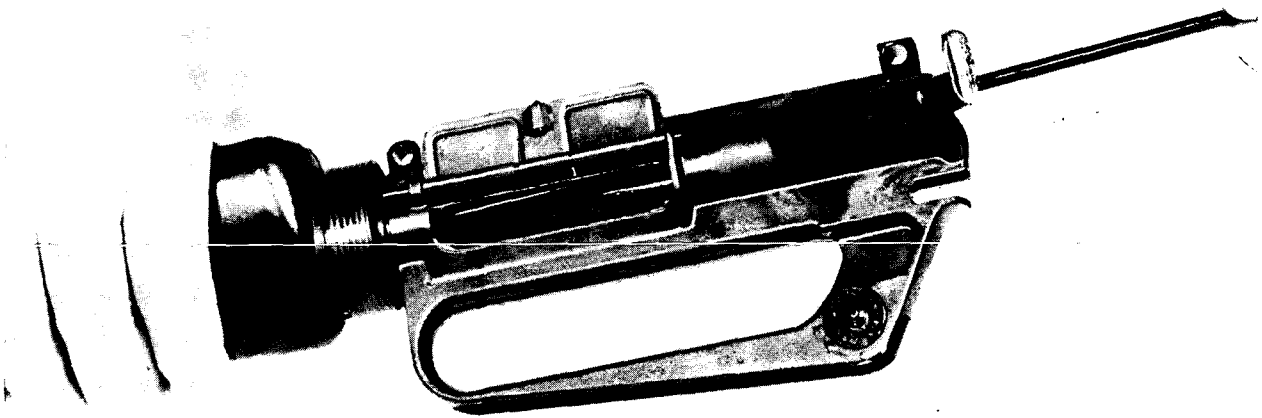

Figure 34. Cleaning bore with cleaning rod and brush.

The top of the gas tube can be cleaned by inserting the rod and brush in the back of the receiver. The sides and bottom of the gas tube can be cleaned from the bottom of the receiver.

Note. Do not use any type of an abrasive material to clean the gas tube.

- (4) After cleaning, lubricate the bore and locking lugs in the barrel extension by applying a light coat of oil to prevent corrosion and pitting. If the handguards have been removed, rub a light coat of oil on the surface of the barrel inclosed by the handguards.

b. Cleaning and Lubricating the Bolt Carrier Group.

- (1) Remove the bolt carrier group from the upper receiver group and disassemble. Clean all parts with a swab dipped in solvent cleaning compound.
- (2) Clean the locking lugs of the bolt, using a small brush and cleaning solvent. Dry with clean patches and oil lightly.
- (3) Clean the bolt carrier key with a bore brush. A used or worn brush should be used if available.
- (4) Put only *one drop* of oil in each hole on the right side of the bolt carrier and the open end of the bolt carrier key. Add a light coat of oil to all surfaces of the bolt and bolt carrier.

Caution: Excessive oil in the firing pin recess of the bolt will result in a

light struck primer and a failure to fire.

Caution: Do not attempt to remove discoloration caused by heat.

Note. A common malfunction is the "freezing" of the bolt carrier key to the gas tube.

c. Cleaning and Lubricating the Lower Receiver Group.

- (1) Cleaning will *not* require detailed disassembly of the lower receiver group. Using a clean, dry patch or bristle brush, remove dirt and sand from the lower receiver. Place only *one drop* of oil on each pin and selector lever shaft for lubrication.
- (2) After extensive use or field exercise, acids caused by perspiration should be removed from exterior surfaces using a rag or swab saturated with bore cleaner, then wiped dry and a light coat of oil applied.

12. Preventive Maintenance

a. Preventive maintenance is the systematic care, inspection, and servicing of equipment to maintain it in serviceable condition, prevent breakdowns, and assure maximum operational readiness. The operator's role in the performance of preventive maintenance service is—

- (1) To perform the service each day the rifle is operated.

Interval and sequence No.			Operator's daily schedule		Paragraph reference
Before firing	During firing	After firing	Item to be inspected	Procedures	
1			Rifle	Wipe oil from bore and chamber.	11a.
2			Rifle	Retract bolt to assure free movement between bolt carrier and gas tube.	11b.
3			Rifle	Function check to assure proper operation.	8g.
4			Rifle	Check magazine for positive retention and functioning of bolt catch.	10c(2).
		5	Rifle	Clean and lubricate. Particular attention to clean bolt carrier key.	11b.

Figure 35. Preventive maintenance checks and services.

- (2) To assist the organizational maintenance mechanics in the performance of any other scheduled periodic services specified by pertinent technical manuals.

b. Figure 35 gives the specific procedures to be performed on the rifle by the operator for each daily service.

Section IV. STOPPAGES AND IMMEDIATE ACTION

14. Stoppages

A stoppage is any unintentional interruption in the cycle of operation. Immediate action must be taken to clear the stoppage.

15. Immediate Action

Immediate action is the unhesitating application of a probable remedy to reduce a stoppage without investigating the cause. Immediate ac-

13. Functioning Check

Each time the weapon is disassembled and cleaned, a check should be made to insure that all parts are properly assembled and the mechanisms are working properly in the SAFE, SEMI, and AUTO settings.

Note. For functioning checks see paragraph 8g.

tion when clearing a stoppage in the XM16E1 consists of the following steps:

- a. Strike upward on the bottom of the magazine to insure that it is fully seated.
- b. Pull the charging handle fully to the rear and release it.
- c. Strike the forward assist assembly to insure that the bolt is fully seated.
- d. Attempt to fire the weapon.

Section V. AMMUNITION

16. General

This section includes available information on the types of ammunition used with the XM16E1 rifle. The types of ammunition are for the purposes indicated.

17. Classification

a. *Cartridge, 5.56-mm, ball, M193.* The ball ammunition is a 5.56-mm, center fire cartridge with a 55 grain, gilding-metal jacketed, lead alloy core bullet. The primer and case are waterproofed. The ball round is the basic cartridge for field use and has no identifying marks.

b. *Cartridge, 5.56-mm, tracer, M196.* The tracer ammunition has the same basic characteristics as the ball. It is identified by an orange-painted tip. Its primary uses are for observation of fire, incendiary effect, and signaling.

c. *Cartridge, 5.56-mm, blank, XM200.* The characteristics of the blank ammunition are not currently known, as the item is still under development.

18. Packaging

Presently there are 20 rounds per carton, and 36 cartons (720 rounds) per metal box, M2A1; 2 metal boxes (1,440 rounds) per wire-bound box.

19. Care and Cleaning

a. When necessary to store ammunition in the open, raise it on dunnage at least 6 inches from the ground and protect it with a cover, leaving enough space for circulation of air.

b. Since ammunition and explosives are adversely affected by moisture and high temperature, due consideration should be given to (1) and (2) below:

- (1) Do not open boxes until ammunition is to be used. Ammunition removed from airtight containers, particularly in damp climates, is apt to corrode.
- (2) Protect ammunition from high temperatures and the direct rays of the sun. More uniform firing is obtained if rounds are at the same temperature.

c. Do not attempt to disassemble the cartridge or any of its components.

d. The use of oil or grease on cartridges is prohibited.

e. Ammunition should be protected from sand,

mud, moisture, frost, snow, ice, grease, and other foreign matter. If it gets wet or dirty, it should be wiped off at once.

f. Brass cartridge cases are easily dented and should be protected from hard knocks or blows.

Section VI. DESTRUCTION OF MATERIEL TO PREVENT ENEMY USE

20. General

Destruction of the XM16E1, when subject to capture or abandonment in the combat zone, will be undertaken by the using unit only when, in the judgment of the unit commander concerned, such action is necessary in accordance with orders of, or policy established by, the army commander. The following priorities should be followed when destroying small arms weapons:

a. Breech mechanisms.

b. Barrel.

c. Sighting equipment (including infrared).

d. Mounts.

21. Methods

The information which follows is for guidance only. Certain of the procedures require the use of explosives and incendiary grenades which

normally may not be authorized items of issue to the using organization. Of the several means of destruction, those most generally applicable are:

a. *Mechanical*—requires axe, pick mattock, sledge, crowbar, or similar implement.

b. *Burning*—requires gasoline, oil, incendiary grenades, or other flammables.

c. *Demolition*—requires suitable explosives or ammunition (see note).

d. *Gunfire*—includes artillery, machineguns, rifles using rifle grenades, and launchers using antitank rockets (see note).

e. *Disposal*—requires burying, dumping in streams or marshes, or scattering so widely as to preclude recovery of essential parts.

Note. Generally applicable only when the rifle is to be destroyed in conjunction with other equipment.

Chapter 3

MARKSMANSHIP TRAINING

Section I. PREPARATORY MARKSMANSHIP

22. General

With very few exceptions, the preparatory marksmanship training for the XM16E1 is identical to that for the M14 (FM 23-71) and M14A2 (FM 23-16) rifles. With any weapon, the foundation upon which good marksmanship is built is preparatory training. Here the rifleman learns the fundamentals which must be applied throughout his training and in combat. This chapter is devoted to the training necessary to produce an effective rifleman.

23. The Integrated Act of Shooting

a. *Aiming.*

- (1) In aiming, the firer is concerned with correctly pointing his rifle so that the bullet will hit the target when he fires. To do this, he must have the rear sight, the front sight, and the target, or aiming point, in their proper relationship. This relationship is known as sight picture. Sight picture involves two elements: sight alinement and placement of the aiming point.
- (2) The techniques of aiming the XM16E1 rifle are the same as for the M14 rifle (FM 23-71).

b. *Steady Hold.* Steady hold is the technique of holding the weapon as steady as possible while obtaining a sight picture and firing. There are eight factors which affect holding a weapon steady. These factors are basically the same for all firing positions; however, the precise manner in which they are applied differs slightly with the various firing positions. This discussion of the steady hold factors will be as they apply to the semiautomatic firing positions.

- (1) *Grasp of the left hand.* The rifle should rest in the V formed by the thumb and forefinger of the left hand, and lie across the heel of the hand. The grip on the handguard should be relaxed but, at the same time, exert a slight rearward pressure. The handguards are gripped at a point which suits both the conformation of the firer's body and the location of the target. If the target is high, the left hand is moved closer to the body, thereby rising the muzzle of the weapon. Conversely, if the target is low, the left hand is moved forward, causing a corresponding drop in the muzzle of the weapon. The left wrist should be as straight as possible, and the left elbow directly under the receiver of the weapon, or as close to this position as the conformation of the firer's body will permit (fig. 36).
- (2) *Rifle butt in the pocket of the shoulder.* The firer must place the butt of the stock firmly into the pocket formed in his right shoulder (fig. 37). The proper placement of the butt of the stock lessens the effect of recoil, helps steady the weapon, and prevents the butt of the stock from riding up on the shoulder.
- (3) *Grip of the right hand.* The right hand grasps the pistol grip so that the pistol grip rests in the V formed by the thumb and forefinger (fig. 38). The forefinger (trigger finger) is placed on the trigger so that daylight shows between the side of the stock and the finger. The remaining fingers are wrapped tightly around the pistol grip. A firm rearward pressure must be exerted by the right hand

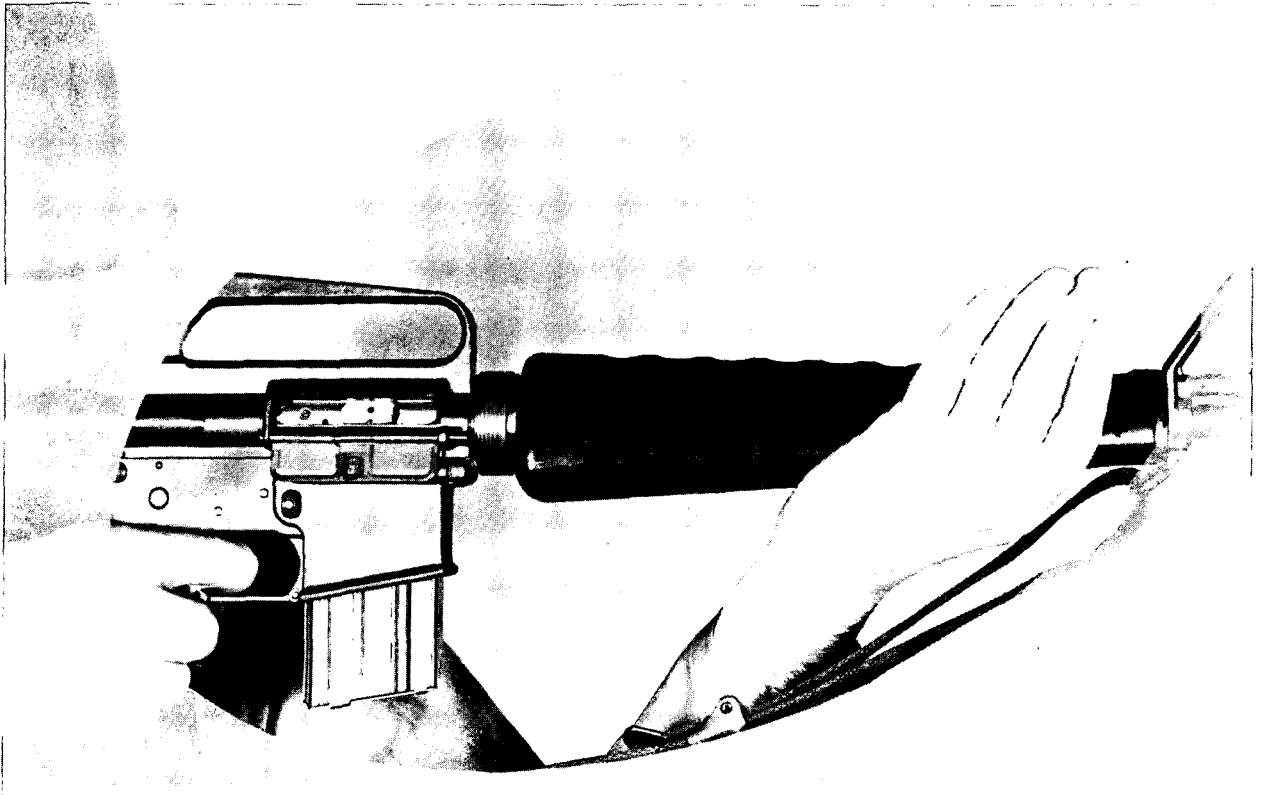

Figure 36. Grip of the left hand (semiautomatic fire).

to keep the butt of the stock in its proper position in the pocket of the shoulder, and secure enough against the shoulder to minimize the effects of recoil.

- (4) *Right elbow.* The location of the right elbow is important because it provides balance to the firer's position. Correct positioning of the right elbow helps to form a pocket in the shoulder for the butt of the stock (fig. 39). The exact location of the right elbow varies in each firing position and is described in the explanation of the firing positions.
- (5) *Stock weld.* The stock weld has two functions. First, the firer, by placing his cheek against the same place on the stock each time he fires, keeps his eye in the same relationship with the sights, assuring a consistent sight picture and accuracy. Secondly, by placing the cheek firmly against the stock, the weapon and

the firer's head recoil together reducing the amount of time required to recover and aim between shots (fig. 40).

- (6) *Breathing.* If the rifleman breathes while trying to aim and fire his weapon, the rise and fall of his chest will cause a corresponding rise and fall in the muzzle of the rifle. If the firer employs improper breathing techniques, holding a sight picture long enough to shoot accurately will be difficult for him. To avoid this, the firer should take advantage of the rising and falling of the muzzle caused by breathing to aim precisely. The firer should take a few short breaths, then inhale and exhale slowly while establishing and maintaining proper sight alignment and lock his throat when the sights rise to the proper position on the aiming point. In this manner the firer can maintain the proper

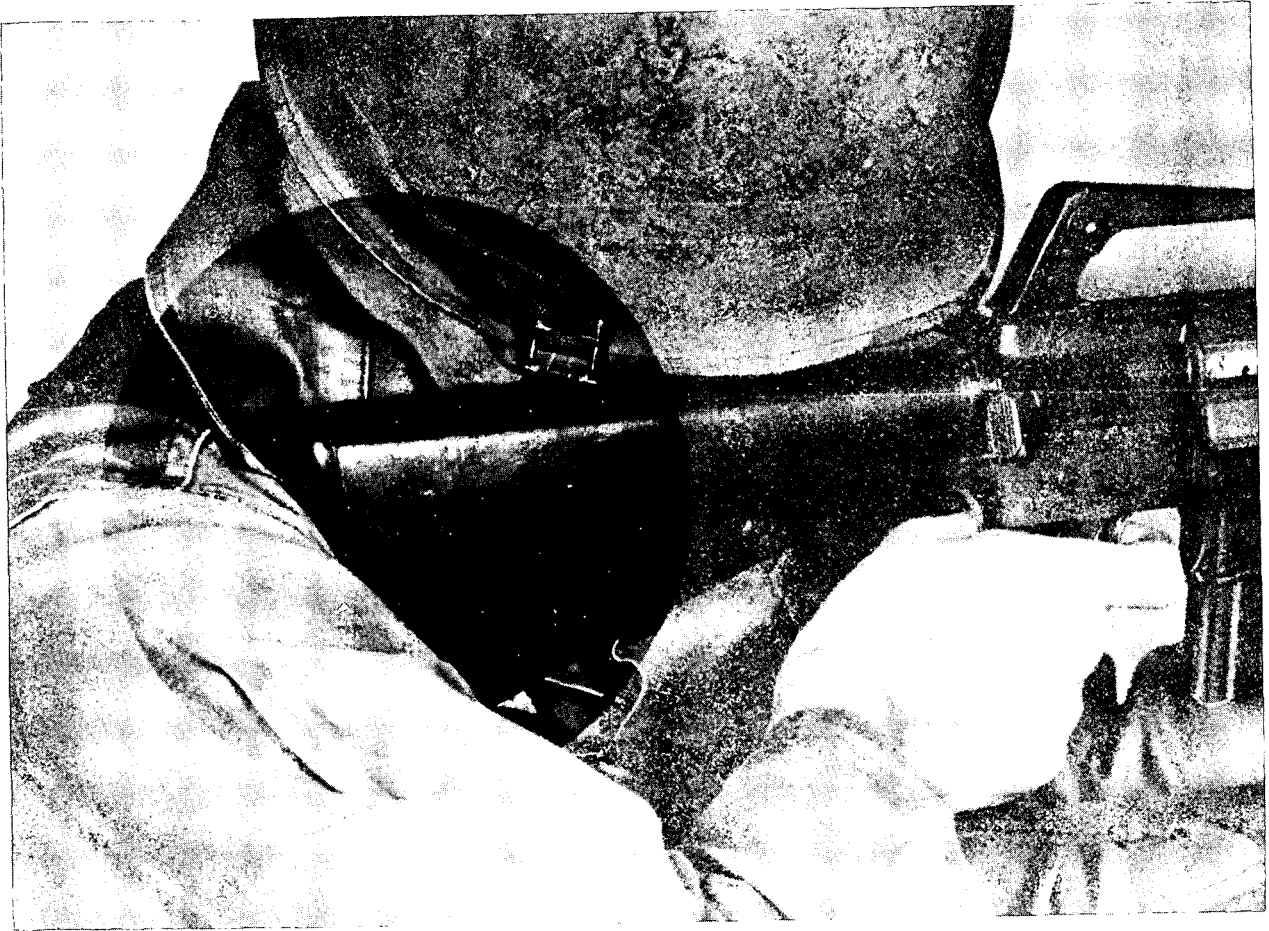

Figure 37. Rifle butt in the pocket of the shoulder.

attitude of relaxation, (7) below, without exerting any muscle tension to move the rifle to the aiming point. Apply pressure on the trigger until the weapon fires. If the weapon does not fire in approximately 10 seconds, he should repeat the cycle above because his vision will blur after that time.

- (7) *Relaxation.* The soldier must learn to relax as much as possible in the various firing positions. Undue muscle strain or tension causes trembling which is transmitted to the weapon. If he finds that a particular position causes excessive strain, he should vary the position slightly until the cause of the strain has been eliminated. The firer must use relaxation to determine that he has a natural position. This is accomplished by relaxing when in position and checking to see if the sight picture is correct. If

the sight picture is not correct, the firer should move his body until a relaxed position and the desired point of aim are achieved. Muscle tension should *not* be used to hold the weapon in the *semi-automatic firing positions.*

- (8) *Trigger control.* Trigger control is the independent action of the forefinger on the trigger. The forefinger should contact the trigger at some point between the fingertip and the second joint of the finger. Since the trigger must be brought straight to the rear, the finger must not touch the side of the stock as this will cause pressure to be applied at a slight angle rather than straight to the rear (fig. 41). Side pressure on the rifle, no matter how slight, will tend to pull the sights off the aiming point. Correctly applied pressure on the trigger causes no movement on the rifle barrel. Trigger

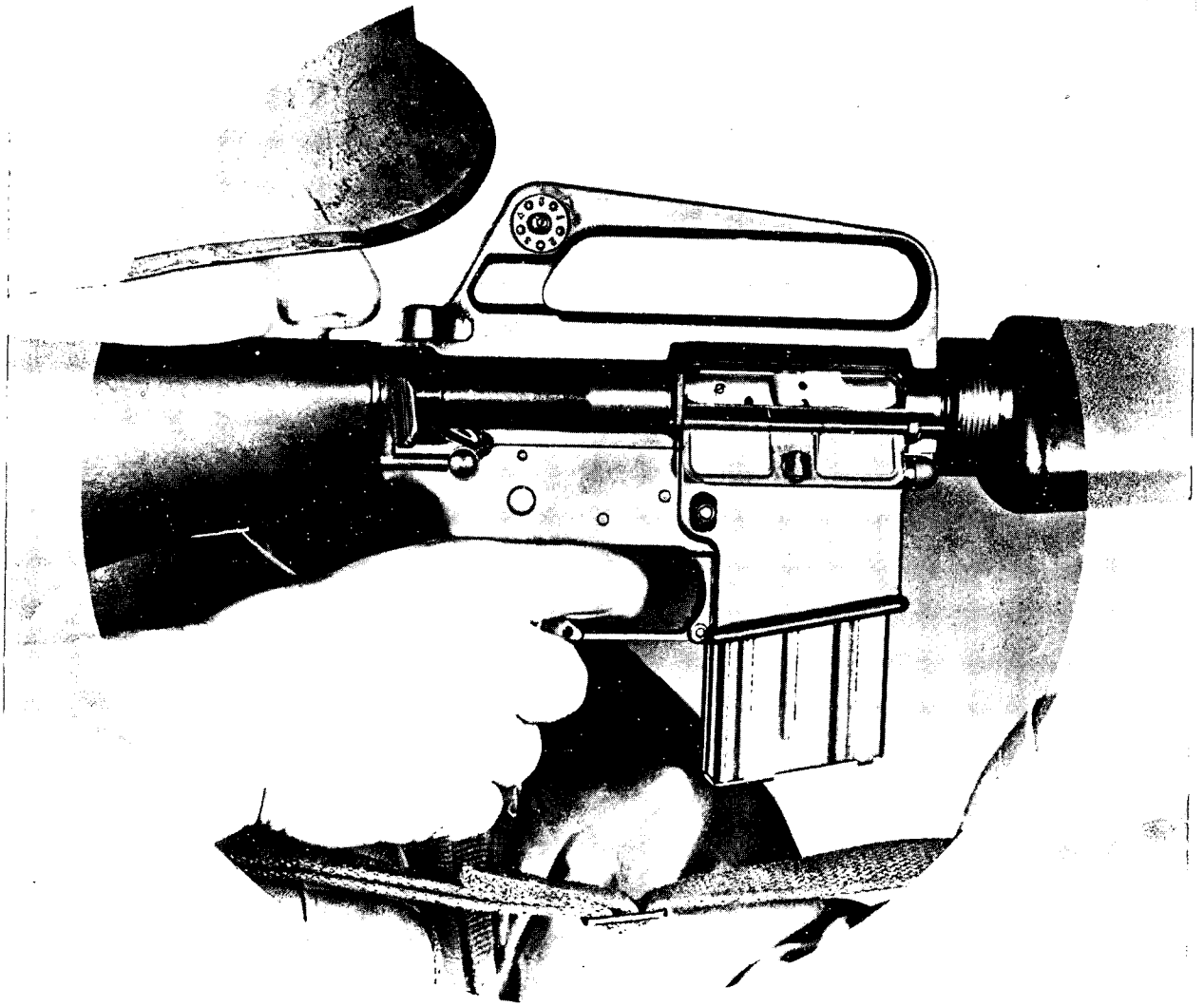

Figure 38. Grip of the right hand.

control is the most important of the steady hold factors and without its proper application, the other marksmanship skills are practically useless.

24. Semiautomatic Firing Positions

a. Semiautomatic Fire. Semiautomatic fire normally is used whenever pinpoint accuracy is required. To deliver semiautomatic fire, any of the firing positions taught in rifle marksmanship for the M14 rifle can be used.

b. Positions. During initial training in the fundamentals of marksmanship, positions are taught as a step-by-step process. That is, the firer is guided through a series of precise movements until he is in the correct firing position. As pro-

ficiency in assuming a position increases the firer will take up a good position in one smooth movement.

c. Prone Position (fig. 42). Whenever the soldier delivers semiautomatic fire from the prone position, the bipod may be used to gain the added stability that it provides. The bipod supported prone position is described in paragraph 25*c*. If the bipod is not used, the left hand grips the handguards as described in paragraph 23*b*(1) above.

d. Sitting Position. The sitting position is especially suitable for use on a slope where the target is approximately the same level as, or lower than, the firer. The sitting position may be used whenever the firer needs better observation



Figure 39. Right elbow.

than he can get from the prone position. The firer should use the variation of the sitting position which best fits the conformation of his body.

- (1) *Open-legged sitting position.* To get into the open-legged sitting position, the firer initially faces the target as when getting into the prone position, then executes a half-right face and spreads his feet well apart. He removes his right hand from the pistol grip and sits down, breaking his fall with his right hand (1, fig. 43). He slides his buttocks well to the rear and points his toes inward, allowing the weight of his legs to rest on the inside of his heels. The firer bends his body forward from the hips and places his left upper arm on the flat por-

tion of his left shin, places the butt of the stock into the pocket formed in his right shoulder, and takes the proper grip on the pistol grip with his right hand. The firer locks his right elbow on the inside of his right knee and exerts a slight rearward pressure with his right hand. To complete the position, the firer obtains a stock weld and relaxes (2, fig. 43).

- (2) *Cross-ankle sitting position* (fig. 44). To get into the cross-ankle sitting position, the firer first sits down in the manner prescribed for the open-legged sitting position. He then crosses his left ankle over his right ankle. The firer places his left upper arm across the shin-bone of his left leg. With his right



Figure 40. Stock weld.

hand, he positions the butt of the stock into the pocket formed in his right shoulder. He places his right elbow so that his right upper arm is in contact with the shinbone of his right leg. To complete the position, the firer obtains a stock weld and relaxes. This firing position can be adjusted for a particular individual by varying the distance the feet are extended from the body.

- (3) *Cross-legged sitting position* (fig. 45). To get into the cross-legged sitting position, the firer first sits down in the manner prescribed for the open-legged sitting position. He then crosses his left leg over his right leg and draws both of his feet up close to his buttocks. He

places his left upper arm against the shinbone of his left leg. With his right hand, he places the butt of the stock into the pocket in his right shoulder and takes the proper grip on the pistol grip. The firer lowers his right elbow so that his right upper arm is against the shinbone of his right leg. To complete the position, the firer obtains a stock weld and relaxes.

- (4) *Comparison of the sitting positions.* In the open-legged sitting position, the body comes into contact with the ground at three distinct points—the heel of each foot and the buttocks. In the cross-ankle sitting position, the body comes into contact with the ground at two

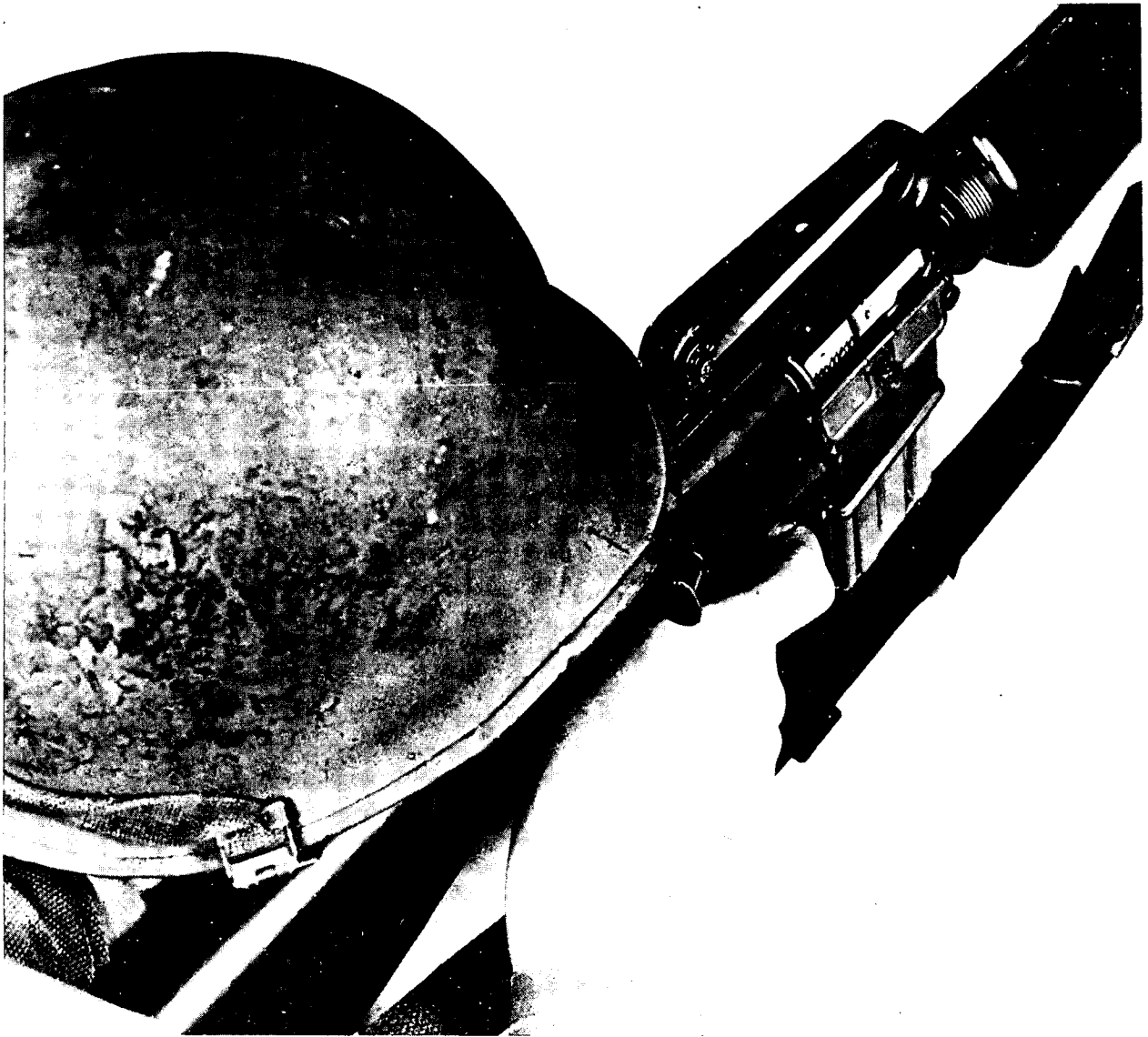

Figure 41. Position of the trigger finger.

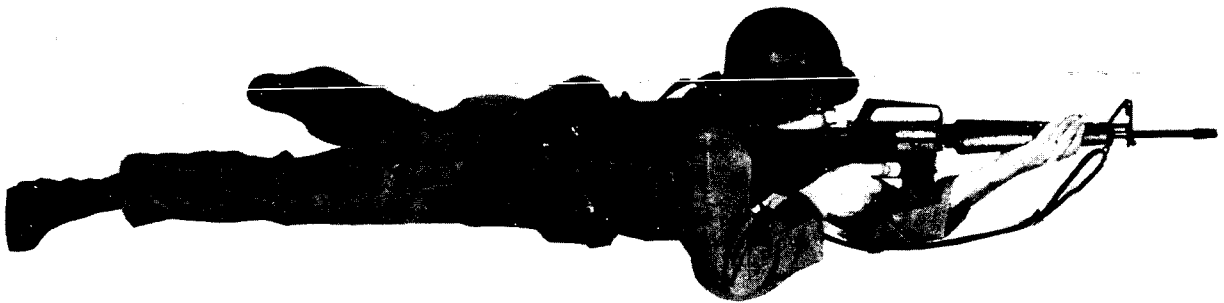

Figure 42. Prone position (without bipod).



1 Breaking the fall

Figure 43. Open-legged sitting position.

points, and in the cross-legged sitting position, one point. The firer should use the position which affords him the greatest stability.

e. Squatting position (fig. 46). The squatting position is a relatively steady position which can be gotten into rapidly. Since only the feet come into contact with the ground, the squatting posi-

tion is an excellent position to use in mud, shallow water, or a contaminated area. The squatting position is best suited for use on level ground or on ground which slopes gently downward. To assume the squatting position, the firer initially faces his target as when getting into the prone position. He then executes a half-right face, spreads his feet a comfortable distance apart, and squats as



2 Sitting position

Figure 43—Continued.

low as possible. For stability, he must keep both feet flat on the ground. The left upper arm is placed firmly against the inside of the left knee. With his right hand, the firer places the butt of the stock into the pocket in his right shoulder and takes the proper grip on the pistol grip. He then lowers his right elbow and blocks it against the inside of his right knee. To complete the position, the firer obtains a stock weld and relaxes.

f. Kneeling positions. These positions are suitable for use on level ground or on ground which slopes gently upward, and can be adjusted in height. The kneeling positions are readily adapted to support, such as trees, the corners of buildings, or vehicles.

- (1) *Kneeling unsupported position* (fig. 47).
To assume the kneeling unsupported

position, the firer initially faces his target as when getting into the prone position, then executes a right face and places his left foot to his left front with his toe pointing toward the target. He kneels down on his right knee and sits on his right heel, the instep of his right foot being flat on the ground. He places his left upper arm onto the flat position of his left knee. With his right hand, he places the butt of the stock into the pocket formed in his right shoulder. His right elbow should be held approximately 45 degrees below horizontal. To complete the position, the firer shifts his weight forward, obtains a stock weld, and relaxes. Figure 47 shows two alternate methods of positioning the right foot when getting into the kneeling



Figure 44. Cross-ankle sitting position.

positions. The firer should use the position of the right foot which best suits the conformation of his body.

- (2) *Kneeling supported position* (fig. 48). To get into the kneeling supported position, the firer first gets into the kneeling unsupported position. He then shifts his weight forward and allows his left shoulder, left arm, and left leg to come into contact with the support. The rifle must not touch or rest on the support, since the contact of the weapon against the support would slow recovery between shots and limit the firer's ability to rapidly shift his point of aim.

g. Standing position (fig. 49). The standing position can be used effectively to engage targets at ranges less than 100 meters when no other position can be assumed. It is the least stable of

the firing positions and must be used only for semiautomatic fire. To get into the standing position, the firer initially faces his target, then executes a right face and spreads his feet a comfortable distance apart. With his left hand, the firer grips the handguards. He positions his left elbow as nearly under the rifle as possible. With his right hand, he places the butt of the stock into the pocket in his right shoulder, then takes the proper grip on the pistol grip. The firer holds his right elbow approximately horizontal, or slightly lower, to provide a good pocket in his right shoulder and to avoid canting the weapon. A strong rearward pressure is exerted with his right hand and arm (he holds most of the weight of the rifle with his right hand and arm). To complete the position, the firer shifts his feet until he is aiming naturally at the target and distributes his weight evenly on both of his hips, obtains a stock weld, and relaxes.



Figure 45. Cross-legged sitting position.

h. Foxhole Position (fig. 50). The foxhole position is the same when using semiautomatic fire as when using automatic fire, and it is discussed in paragraph 25*d*. The bipod may be used to gain added stability.

i. Semiautomatic Fire Coaching Positions. As a general rule, the coach's position is similar to that of the firer. The coach should locate himself in relation to his firer in a manner which will permit observation of the firer's application of the steady hold factors. The coach should exercise care not to place himself so far forward of his firer as to be in the path of the ejected cartridge casings.

25. Automatic Firing Positions

a. General.

(1) Position is the single most important

fundamental of *automatic* rifle marksmanship. Without the proper firing position, it is impossible for the rifleman to achieve consistent hits on the target during firing. After the first round of a burst has been fired, a correct sight picture is difficult to maintain. Therefore, to continue hitting the target with the remaining rounds in a burst, the firer must maintain the correct firing position. A burst of automatic fire is defined as a series of shots fired from an automatic weapon by one press of the trigger.

(2) There are three positions used with the XM16E1 rifle when using automatic fire. These are the bipod supported



Figure 46. Squatting position.

prone, bipod supported foxhole, and
in.terarm positions.

b. Steady Hold. Steady hold for the automatic firing positions is essentially the same as for the semiautomatic firing positions discussed in paragraph 23*b*, except for the following:

- (1) *Left arm and grip of the left hand.* The left hand grips the forward edge of the magazine feedway, the fingers of the left hand on the right side of the feedway, and the thumb on the left side (fig. 51). The left hand exerts a firm pressure rearward to help keep the butt of the stock into the pocket in the right shoulder and to increase ground pressure on the bipod legs, thus minimizing muzzle climb.

- (2) *Right elbow.* The location of the right elbow is important because it provides balance to the firer's position. Connect positioning of the right elbow helps form a pocket in the shoulder for the butt of the stock and causes the shoulders to be level. The right elbow should be placed on the ground with the right upper arm forming an angle as near to 90 degrees with the ground as is consistent with the shoulders being level.
- (3) *Breathing.* When firing automatically, the firer must learn to exhale and inhale after burst developing a rhythm during firing.
- (4) *Muscular tension.* Contrary to the necessity of relaxation in semiautomatic rifle



1

Figure 47. Kneeling unsupported position.

firing, muscular tension (of parts of the firer's body) is a necessary steady hold factor. This can be accomplished only by tensing the muscles of the upper arms. The stronger the pressure applied to the weapon by the tensing of the muscles of the upper arms (all other factors being correctly applied), the less dispersed will be the rounds in a burst of automatic fire. Although the muscles tensed are primarily those in his upper arms, the firer will experience a certain tensing of his abdominal muscles.

- (5) *Trigger control.* Trigger control is the independent action of the trigger finger pressing the trigger straight to the rear until the desired number of rounds have been fired in a burst of automatic fire, then releasing the trigger. The firer must be taught to press the trigger in a manner that will permit him to fire a short burst (2 or 3 rounds). The trigger finger is placed on the trigger at a point between the fingertip and second joint of the finger (fig. 41). The trigger finger should not touch the side of the

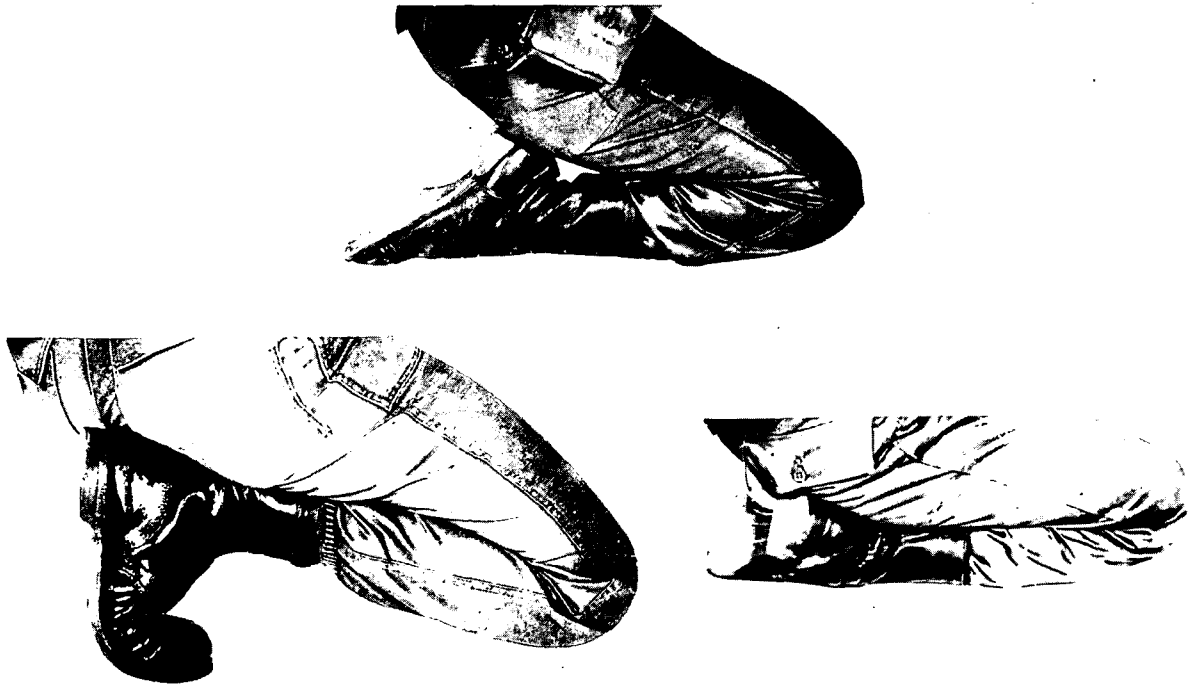

2

Figure 47—Continued.

pistol grip as this will cause pressure to be applied at a slight angle rather than straight to the rear. Such pressure, no matter how slight, will disturb the weapon.

c. Bipod Supported Prone Position.

(1) The bipod supported prone position is the most stable position and should be used whenever possible. To get into the bipod supported prone position, the firer initially stands facing his target, holding the rifle with his left hand on the handguards, his left arm thrust forward; his right hand grasps the pistol grip, and the butt of the stock is held against his right hip (1, fig. 52). The muzzle of the weapon is pointed slightly up and down range. The firer spreads his feet a comfortable distance apart and drops to his knees, removing his right hand from the weapon (2, fig. 52). He falls

forward, breaking his fall with his right hand well forward of his right knee, and on line with his right knee and his target (3, fig. 52). He extends his left arm forward and places the rifle on the ground and lowers himself onto his left side and elbow (4, fig. 52). He places the butt of the stock into the pocket in his right shoulder (fig. 37) with his right hand, and then takes the proper grip on the pistol grip (fig. 38), lowering his right elbow to the ground. The firer takes the proper grip on the magazine feedway with his left hand (fig. 51). The firer's legs should be spread a comfortable distance apart, and his heels should be as close to the ground as the conformation of his body will permit. For maximum stability, his body should be directly behind the weapon. To complete the position, the firer obtains a stock weld (5, fig. 52).



Figure 48. The kneeling supported position.

(2) The coach initially takes his position three steps to the rear of the firer. From this position, the coach tells the firer which way to move to obtain correct body alinement. Correct body alinement is achieved when the firer's body is directly behind his weapon and an imaginary line will pass down the long axis of the weapon, across the firer's right shoulder and over his right buttock.

When the firer's body is in the correct relationship with his rifle, the coach moves forward and checks the firer's legs and feet. Using the steady hold factors as a guide, the coach checks the other characteristics of the firer's position. Having accomplished this, the coach will move to his initial position three steps to the rear of the firer and recheck the firer's body alinement. The



Figure 49. Standing position.

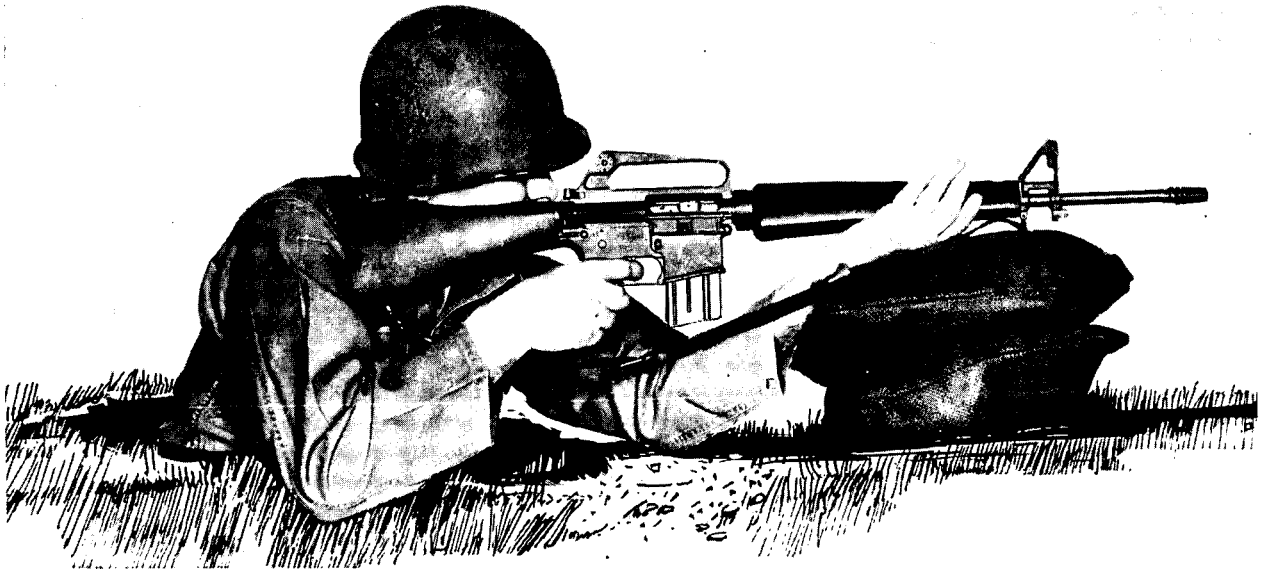

Figure 50. Foxhole position (without bipod).

coach will then get into the coaching position on the right side of the firer and continue to observe the firer's application of the steady hold factors.

d. Bipod Supported Foxhole Position.

- (1) The bipod supported foxhole position (fig. 53) is used whenever defensive positions have been prepared. To assume the bipod supported foxhole position, the firer moves to the foxhole and places his rifle alongside it. The firer enters the foxhole, adding or removing dirt or sandbags to adjust the foxhole to his height. The firer then grasps his rifle and places his chest against the forward wall of the foxhole, keeping the muzzle of his weapon pointed slightly up and down range. For maximum stability, the firer braces the bottom of his right foot against the back of his foxhole. Placing the bipod of his rifle on the ground forward of his foxhole, the firer grips his weapon the same way he would in the bipod supported prone position.
- (2) The coach checks the firer's position, using the steady hold factors as a guide, and then gets into the coaching position (the same as for the bipod supported prone position).

e. Underarm Position.

- (1) The underarm firing position (fig. 54) is used to engage targets at close ranges, during the assault, or any time the rifleman is required to fire while moving. To get into the underarm firing position, the firer initially stands facing his target as he would in the bipod supported prone position. He then spreads his feet approximately shoulder width apart and takes one step forward with his left foot. The weight of his body should be equally distributed on both of his feet, and his knees should be slightly flexed as in a boxer's stance. The butt of the stock is positioned as nearly under the arm pit as the conformation of his body will allow. His right arm is lowered so that the butt of the stock is held firmly against his side by his upper arm. The left hand should grip the handguards firmly, and the left arm should be extended a comfortable distance forward to permit guiding the muzzle of the rifle in all directions. The muzzle of the weapon should be slightly depressed to minimize overshooting the target, make maximum use of any ricochets, and adjust fire onto the target through observ-



Figure 51. Left arm and grip of the left hand (automatic fire).

- ing the strike of the bullets on the ground. The right hand grips the pistol grip firmly.
- (2) The coach, arms extended and palms out, positions himself two steps behind his firer. This enables the coach to stabilize his firer in the event the firer's position becomes unbalanced.
- (3) The underarm firing position permits the firer to engage targets in any direction. To do this, the firer whirls to face his target by pivoting on the ball of his lead foot and stepping in the new direction with his rear foot.



1 Starting position, firer faces target

Figure 52. The bipod supported prone position.

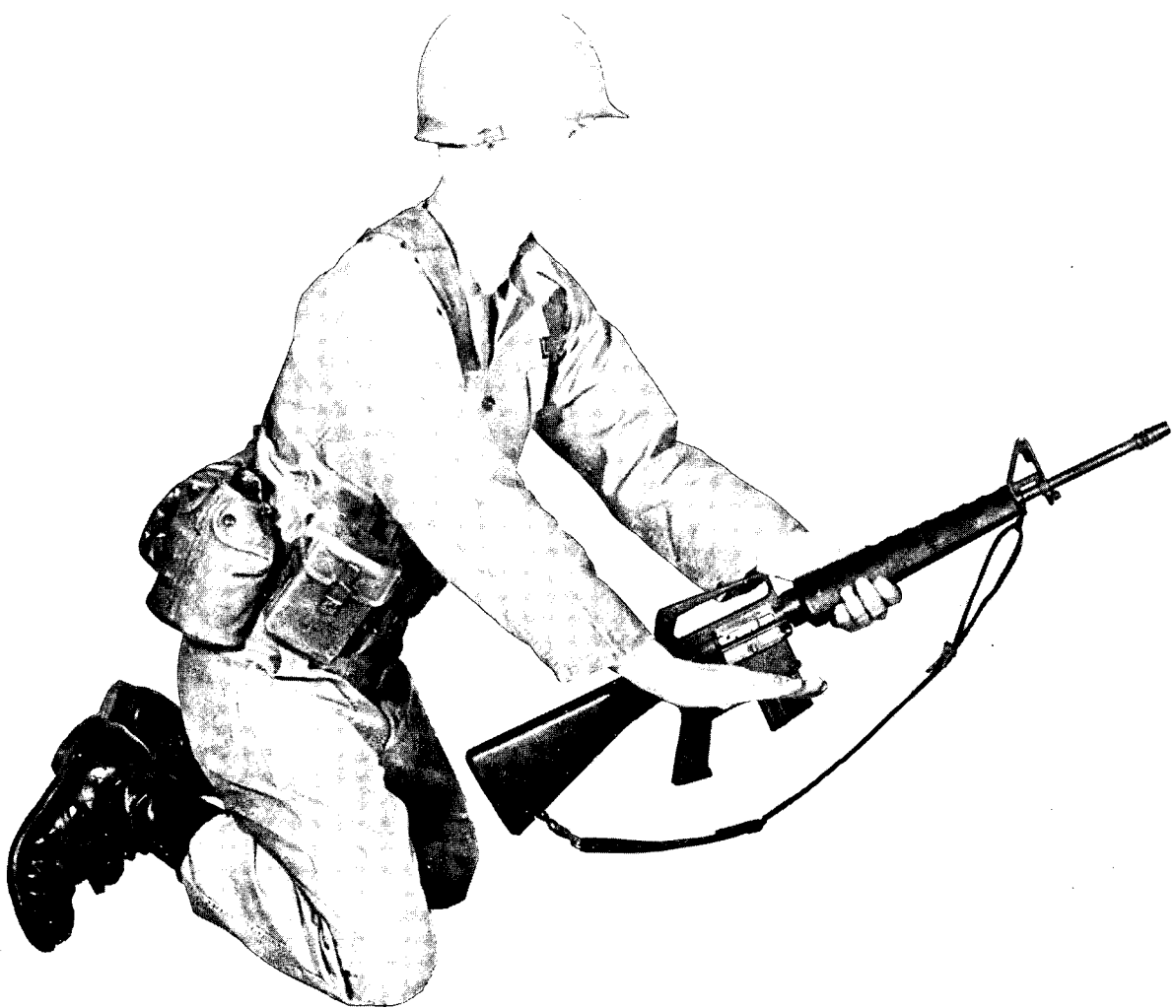

2 Firer drops to his knees

Figure 52—Continued.



3 Firer falls forward
Figure 52—Continued.



4 Firer rolls over on left side and elbow
Figure 52—Continued.

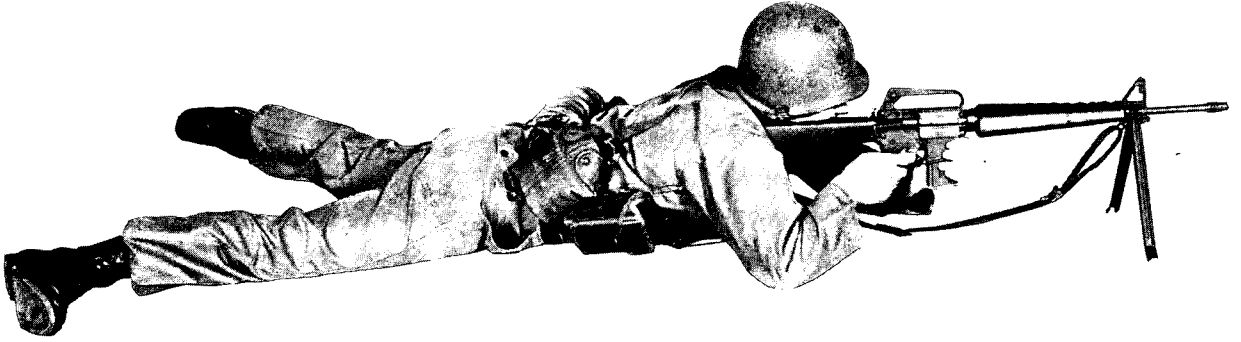

5 Proper position

Figure 52—Continued.

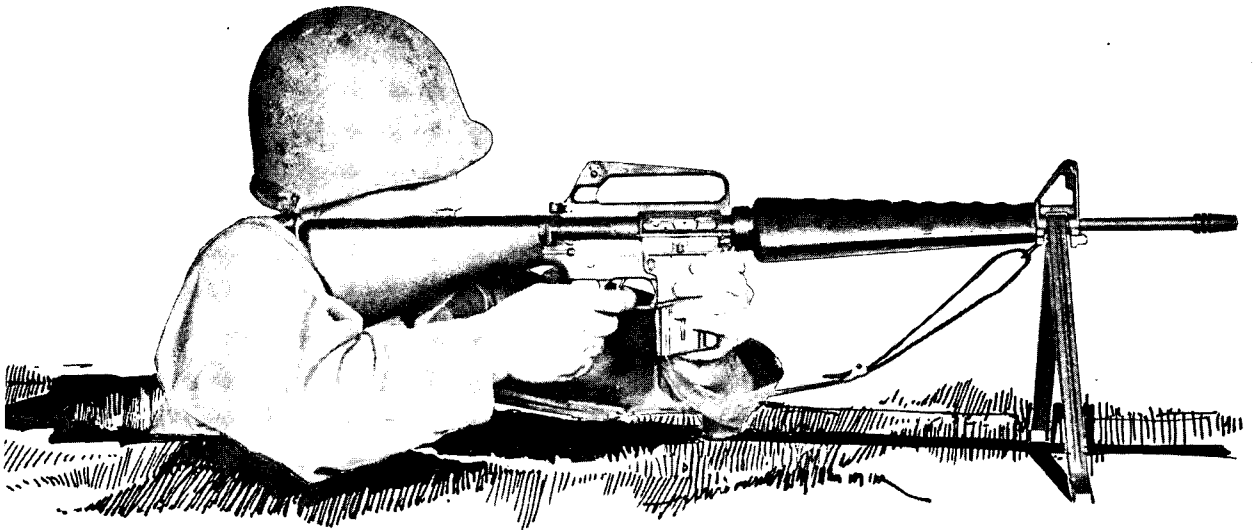

Figure 53. The bipod supported foxhole position.



Figure 54. The underarm firing position.

Section II. AUTOMATIC FIRE

26. General

a. Automatic fire is the firing of two or more consecutive rounds without releasing the trigger. Bursts of two or three rounds are usually fired to insure minimum dispersion. The rifleman must understand the nature of automatic fire and the contracts between *automatic* and *semiautomatic* fire.

- (1) *Semiautomatic fire.* Semiautomatic fire is employed where the range to the target is in *excess* of 460 meters, or in any situation where a high degree of accuracy is required to hit a small point tar-

get; e.g., bunker apertures, windows, and single enemy personnel.

- (2) *Automatic fire.* Automatic fire is employed—
 - (a) When engaging enemy formations at ranges out to 460 meters.
 - (b) When engaging large point targets such as crew-served weapon emplacements, unarmored vehicles, and openings in buildings out to ranges of 460 meters.
 - (c) To attain fire superiority when warranted by the tactical situation.



Figure 55. Proper method of carrying magazines.



Figure 56. Withdrawing magazine from the ammunition pouch (right side).

b. As pointed out in the explanation of the importance of position stability, automatic fire will not be as accurate, per round fired, as semi-automatic fire. This decreased accuracy must be compensated for by the delivery of a heavy volume of fire. A heavy volume of fire is attained in machinegun fire where ammunition is belt-fed and requires no interruption of fire for reloading. However, with a magazine-fed rifle, volume of fire is governed by the rifleman's ability to load and change magazines. Sustained rifle fire

is limited by the capacity of the magazine. To attain a heavy volume of fire, the rifleman must be able to change the magazine in 4 to 5 seconds. This level of proficiency can only be attained through thorough and intensive training in the fundamentals of automatic fire.

c. Automatic fire training develops proficiency in the rapid, systematic handling and changing of magazines. This training insures maximum effective use of the rifle by the firer.



Figure 57. *Withdrawing magazine from ammunition pouch (left side).*

27. Fire Distribution

a. General. The rifleman must be trained to deliver fire at targets which have one or more selected aiming points. When fire is delivered at one aiming point, it is called *concentrated fire*; when it is delivered at more than one aiming point, it is called *distributed fire*.

b. Concentrated Fire. Concentrated fire is fire directed at a specific point which requires a high degree of accuracy. Rifle marksmanship training has taught the soldier to think principally in terms of concentrated fire; he must now be taught to apply the integrated act of automatic rifle shooting to *distribute*, as well as to *concentrate* his fire.

c. Distributed Fire. Distributed fire is fire in depth and width so that a target is effectively covered. The object of distributed fire is to place

a heavy volume of fire between the known or *suspected* flanks of a target. The rifleman must attempt to place fire within the area of such a target. It should be strongly emphasized that the inability to see enemy personnel or positions should not be a reason for failure to fire into an area if there is reason to suspect the presence of a covered or concealed target.

28. Magazine Handling

a. Magazines are placed into each ammunition pouch with the open end of the magazine down, long portion toward the body (fig. 55). This method of placing the magazines into the ammunition pouches enables the firer to quickly remove the magazines.

b. Removing a magazine from the ammunition pouch is the same whether using the right or left hand. To remove a magazine from the pouch,



Figure 58. Rotating the hand and wrist (right side).

grasp the magazine with the thumb on the long edge and the first and second fingers on the short edge (figs. 56 and 57). Withdraw the magazine from the ammunition pouch and extend the arm forward, rotating the hand and wrist (figs. 58 and 59) so that the magazine will be in position (open end up and long edge to the rear) to load into the weapon (figs. 60 and 61). The magazine is loaded into the weapon by inserting the magazine straight up into the magazine feedway until it is seated.

29. Magazine Changing

a. Removing the Empty Magazine. When the ammunition in the magazine in the rifle has been exhausted, the firer removes the magazine from the weapon by pressing the magazine catch button

with his right forefinger (fig. 62) and allowing the magazine to drop, under its own weight, out of the weapon.

b. Right-Side Load. To load a magazine from the right side, the rifleman uses his right hand. After the empty magazine has been removed from the weapon, he secures and loads the next magazine into the weapon. To chamber a round, he depresses the *top* of the bolt catch with the thumb of his left hand (fig. 63), releasing the bolt. If the bolt was not open when the loaded magazine was inserted into the weapon, the firer must pull back on and release the charging handle with his right hand to chamber a round. The left hand should *never* be taken away from the weapon when loading the weapon from the right side.



Figure 59. Rotating the hand and wrist (left side).

c. Left-Side Load. Once the empty magazine is out of the weapon, the rifleman secures and loads the next magazine into the weapon with his *left* hand. Chambering a round is accomplished in the same manner as when loading a magazine into the weapon from the right side. When load-

ing the weapon from the left side, the right hand should *never* be taken away from the weapon.

d. Changing Magazines. When changing magazines, both hands should never be off the weapon *at the same time*.



Figure 60. Magazine in position for loading (right side)



Figure 61. Magazine in position for loading (left side).



Figure 62. Releasing the magazine.



Figure 63. Releasing the bolt.

Chapter 4

SIGHT ADJUSTMENT AND BATTLESIGHT ZERO

Section I. SIGHT ADJUSTMENT

30. General

Following fundamentals training, the soldier must zero his weapon. In order to accomplish this, the soldier must first learn the operation of the sights, the use of the elevation and windage rule, and how to compute sight changes.

31. The Sights

The sights of the XM16E1 rifle are adjustable for both elevation and windage. Windage adjustments are made on the rear sight; elevation adjustments on the front sight.

a. The rear sight consists of two apertures (fig. 64) and a windage drum with a spring loaded stud (fig. 65). The aperture marked *L* is used for ranges from 300 to 500 meters, and the unmarked aperture for ranges from 0 to 300 meters. Adjustments for windage are made by pressing in on the spring loaded stud with a sharp instrument, or the tip of a cartridge, and rotating the windage drum in the desired direction.

b. The front sight consists of a rotating sight post with a spring loaded stud (fig. 66). Adjustments are made by using a sharp instrument, or the tip of a cartridge. To raise or lower the front sight posts, depress the spring loaded stud and rotate the post in the desired direction.

c. During training in marksmanship fundamentals all firing exercises should be conducted with the rear sight of the weapon centered and set on the short range aperture. The front sight post should be set at 24 clicks from its lowest position. This setting should not be changed until the firer is able to fire tight shot groups. The reason for this is twofold: first, untrained firers will tend to focus their attention on manipulating the sights rather than learning to properly apply marksmanship fundamentals. Second,

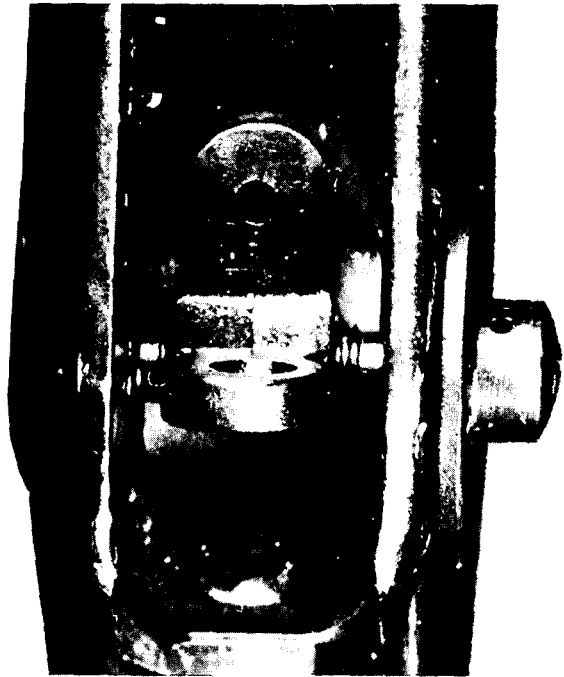

Figure 64. Rear sight apertures.

during fundamental training, the precise location of a shot group on the target is unimportant since it is the size of the shot group, not the location, that governs the proficiency of the firer.

32. Elevation and Windage Rule

The elevation and windage rule states that one click of elevation or windage will move the strike of a bullet a specific distance at a specific range. At a range of 25 meters, one click of either elevation or windage on the sights of the XM16E1 rifle will move the strike of the bullet approximately .7 centimeters. To compute the distance one click will move the strike of a bullet at any given range, multiply the range in hundreds of meters times 3. For example, to compute

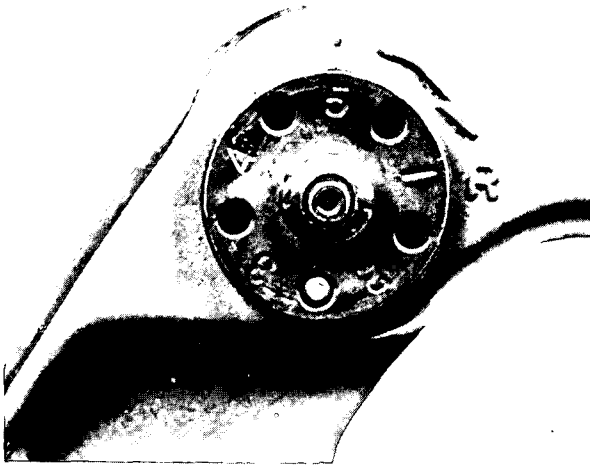

Figure 65. Windage drum.

the distance one click of elevation or windage will move the strike of the bullet at a range of 250 meters, multiply 2.5 by 3. The answer in this case is 7.5 centimeters.

33. Sight Changes

a. To make sight changes, the firer first locates the center of his shot group and then determines the distance between it and the desired location. An error in elevation is measured vertically, while a windage error is measured horizontally. These distances are converted to clicks by using the elevation and windage rule. As a general rule, bold adjustments will prove more advantageous to the firer. For example, if there is a question whether to move two or three clicks, the firer normally should make the adjustment requiring the greater number of clicks.



Figure 66. Front sight.

b. To raise the strike of the bullet, the firer must rotate the front sight post in the direction of the arrow marked UP (stamped on the front sight base); thus, the strike of the bullet is raised but the post is lowered. Reverse the direction of rotation to move the strike of the bullet down. To move the strike of the bullet to the right, rotate the windage drum the desired amount of clicks clockwise (in the direction of the stamped R). Reverse the direction of rotation to move the strike of the bullet to the left.

Section II. BATTLESIGHT ZERO

34. Principles of Zeroing

a. In order to understand the principles of zeroing, the soldier should have a basic knowledge of ballistics: specifically, the relationship between the path of the bullet in flight and the line of sight. In flight, a bullet does not follow a straight line but travels in a curve or arc. This curved flight path of the bullet is called its trajectory (fig. 67). The maximum height (ordinate) of the trajectory of the bullet depends

on the range to the target. The greater the distance a bullet travels before impact, the higher it must travel in its trajectory. On the other hand, the line of sight is a straight line through the rear sight aperture and across the front sight post to the aiming point on the target.

b. When the bullet leaves the muzzle, it is initially below the line of sight. Due to the angle of the bore, the bullet will rise until it reaches its maximum ordinate, at which time it will begin

TRAJECTORY

TRAJECTORY-LINE OF SIGHT RELATIONSHIP

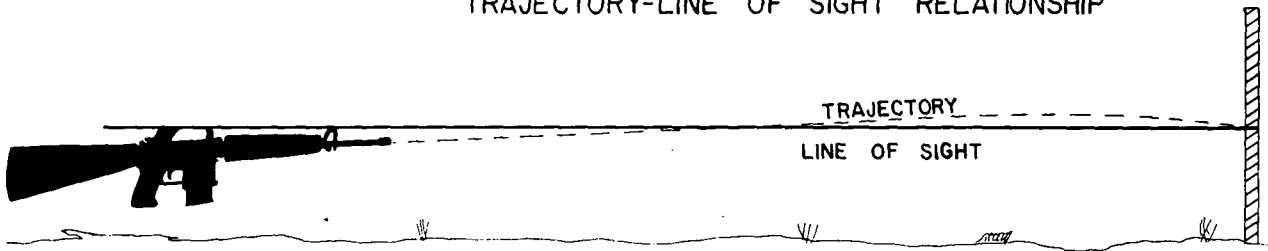

Figure 67. Trajectory.

PRINCIPLES OF BATTLESIGHT ZEROING

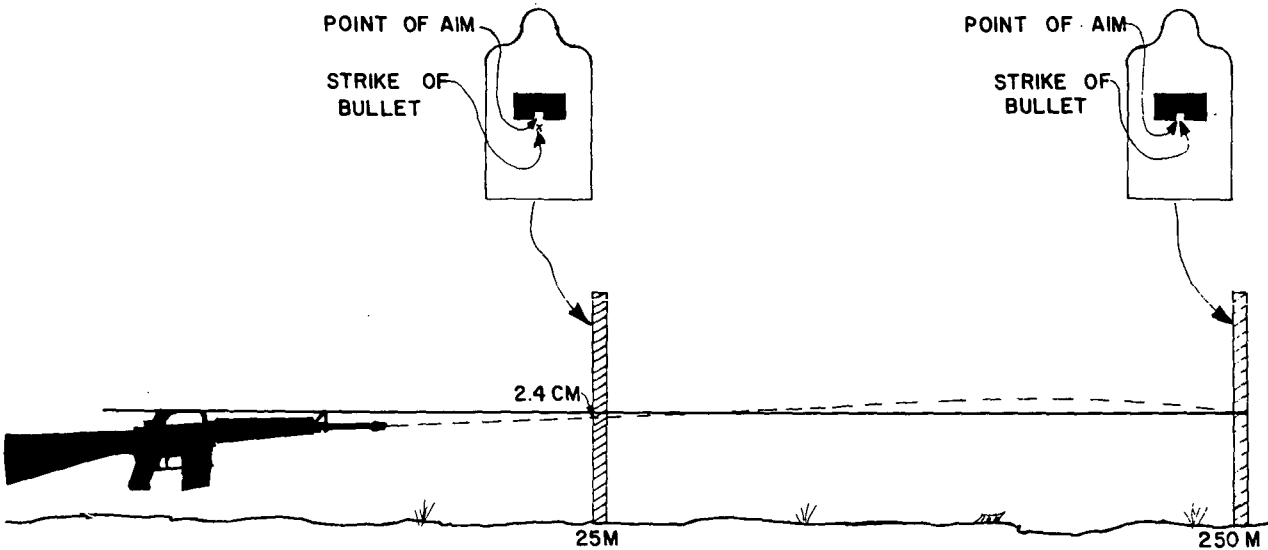

Figure 68. Principles of battlesight zeroing.

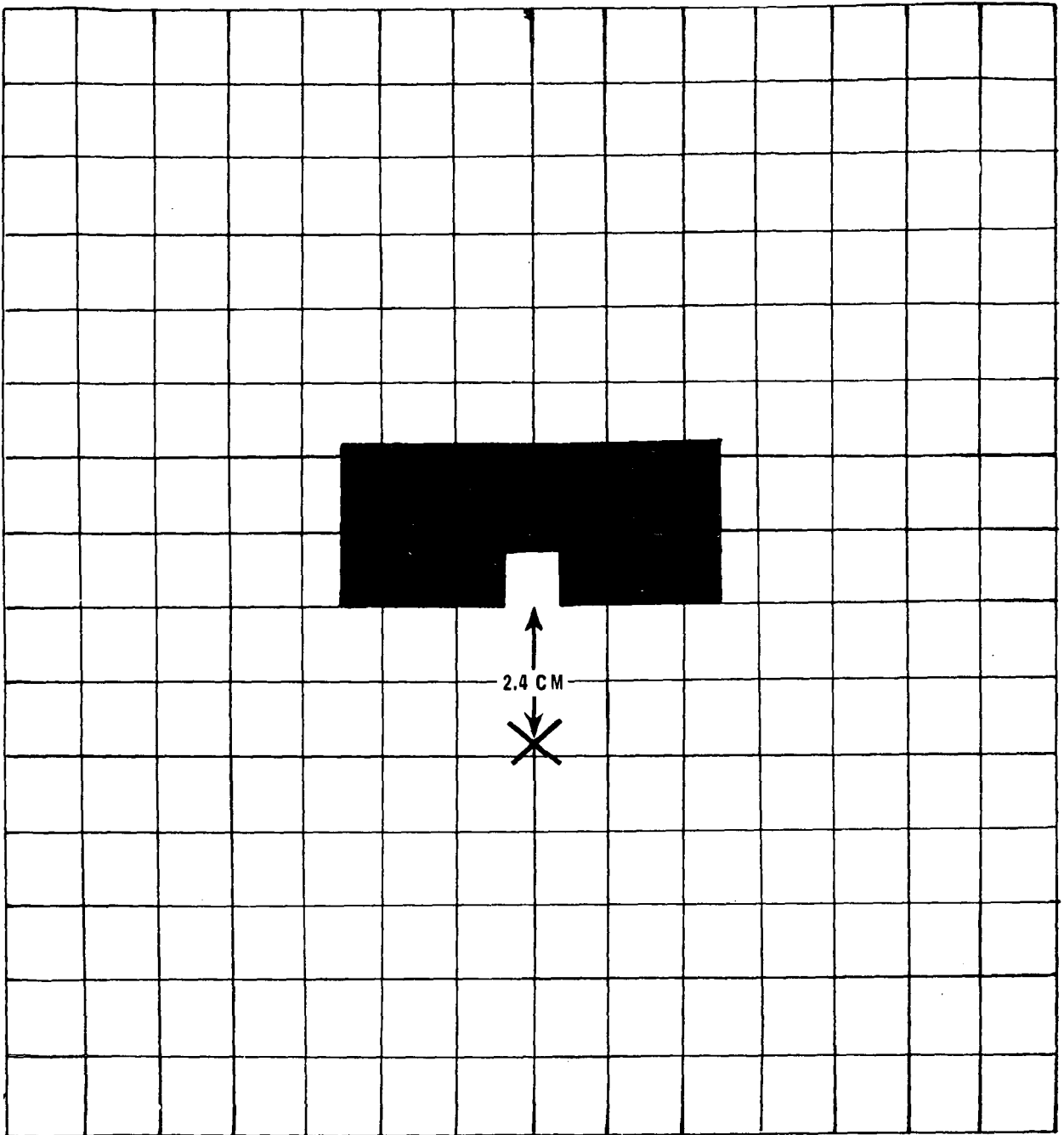

Figure 69. Modified 25-meter (1,000-inch) target (not to scale).

to drop and will eventually intersect the line of sight. The range at which this intersection occurs is the zero for that sight setting.

c. The zero of a weapon is that sight setting in elevation and windage that will cause a hit at the point of aim for a given range.

d. Current doctrine of the United States Army prescribes a battlesight zero for 250 meters. That is, the sights of a weapon should be so adjusted that the trajectory of the bullet and the line of sight intersect at a range of 250 meters. To phrase it another way a soldier firing a weapon

properly zeroed for a range of 250 meters should hit his aiming point at that range.

e. One method of determining the 250 meter battlesight zero would be to fire at a range of 250 meters, making the necessary sight adjustments to place the center of the shot group on the aiming point. However, such a method would require extensive terrain and waste training time while firers moved between the firing line and the targets to check the location of shot groups.

f. A more suitable method of determining the 250-meter battlesight zero can be accomplished at a range of 25 meters or 1,000 inches (fig. 68). This method is based on the principle that bullets of the same type and caliber fired at the same range have the same trajectory. That is, if several bullets were fired from the same weapon and all hit the same 250-meter aiming point, the trajectories of all these bullets are the same. Therefore, when each of these bullets reaches a distance of 25 meters or 1,000 inches from the muzzle of the weapon, they are all the same distance below the firer's line of aim. Thus, by placing an aiming point at a range of 25 meters or 1,000 inches, the firer has only to adjust the weapon sights until his shot group is the prescribed distance below his 25-meter or 1,000-inch aiming point to obtain a zero for 250 meters.

35. Battlesight Zero Target

The standard 25-meter target (FSN 6920-906-0169) previously used during fundamentals training, is locally modified as illustrated in figure 69 when determining a battlesight zero for the XM16E1. In order to use the elevation and windage rule effectively, the firer must know the dimensions of the squares on the target. Vertical and horizontal lines are printed on the target, forming 1.4 centimeter squares. As indi-

cated in paragraph 32, one click of elevation or windage will move the strike of the bullet .7 centimeters at a range of 25 meters. (Although 25 meters is a slightly lesser distance than 1,000 inches, the difference is insignificant, and the same adjustment data can be used for 1,000-inch firing.) Thus, in terms of the 25-meter target, two clicks of elevation or windage will move the strike of the bullet one square.

36. Determining the Battlesight Zero

a. The 250-meter battlesight zero is determined by firing a series of three-round shot groups at the 25-meter target described in paragraph 35. The firer aims at the distinctive aiming point at the bottom center of the black rectangle and adjusts his sights until the center of his shot group is located 2.4 centimeters directly below the aiming point. This point can be designated by an additional *X* drawn on the target (fig. 69). With this sight setting, the point of impact of the bullet and the firer's point of aim will coincide at a range of 250 meters. The average firer will need to fire three or four shot groups in order to accurately determine the battlesight zero of his weapon.

b. Once the battlesight zero has been obtained, there should be no further adjustments of the sights. Later, in field firing exercises, the soldier will learn to hit targets located at ranges other than 250 meters by adjusting his point of aim as described in FM 23-16 and FM 23-71.

c. Either of the two most stable firing positions, the bipod supported foxhole or the bipod supported prone, may be used for obtaining the battlesight zero. However, the position selected must be located the prescribed 25 meters (1,000 inches) from the target.

Appendix REFERENCES

FM 23-8	U.S. Rifle, 7.62-mm, M14 and M14A2.
FM 23-15	Browning Automatic Rifle, Cal. .30, M1918A2.
FM 23-16	Automatic Rifle Marksmanship.
FM 23-71	Rifle Marksmanship.
ASubjSed 7-11B10	Light Weapons Infantryman, MOS 11B10.
ASubjSed 23-14	Interim Automatic Rifle, M14(M) and BAR Qualification.
ASubjSed 23-31	Rifle Marksmanship.
TM 9-1005-249-14	Operation Maintenance, Repair and Replacement Parts, Rifle, 5.56-mm, M16, and Rifle, 5.56-mm, XM16E1.
GTA 7-1-14	Rifle, 5.56-mm, XM16E1, Mechanical Training.

By Order of the Secretary of the Army:

HAROLD K. JOHNSON,
*General, United States Army,
Chief of Staff.*

Official:

J. C. LAMBERT,
*Major General, United States Army,
The Adjutant General.*

Distribution:

Active Army:

DCSPER (2)	Corps (3)
ACSI (2)	Div (5)
DCSLOG (2)	Div Arty (1)
ACSFOR (2)	Bde (3)
CORC (2)	Gp (1)
CNGB (5)	CC (2)
CRD (1)	Bn (2)
COA (1)	Co/Btry (1)
CINFO (1)	USAWC (5)
TIG (1)	USAOC&S (1)
USAIB (1)	Svc Colleges (2)
USCONARC (5)	Br Svc Sch (2)
USAMC (1)	USMA (2)
LOGCOMD (1)	USATC (2)
Armies (5)	

NG: State AG (3); units—same as Active Army except allowance is one copy to each unit.

USAR: Units—same as Active Army except allowance is one copy to each unit.

For explanation of abbreviations used, see AR 320-50.