

MIL.
Copy 3

RESTRICTED

FM 27-15

WAR DEPARTMENT

BASIC FIELD MANUAL



MILITARY LAW
DOMESTIC DISTURBANCES

February 6, 1941

REGRADED UNCLASSIFIED BY
AUTHORITY OF DOD DIR. 5200.1 R
BY BRANZ ON 8/1/03

THE ARMY LIST
WASHINGTON

D

FM 27-15

BASIC FIELD MANUAL



**MILITARY LAW
DOMESTIC DISTURBANCES**

**Prepared under direction of
The Judge Advocate General**



**UNITED STATES
GOVERNMENT PRINTING OFFICE
WASHINGTON : 1941**

WAR DEPARTMENT,

WASHINGTON, February 6, 1941.

FM 27-15, Military Law, Domestic Disturbances, is published for the information and guidance of all concerned.

[A. G. 062.11 (11-30-40).]

BY ORDER OF THE SECRETARY OF WAR:

G. C. MARSHALL,

Chief of Staff.

OFFICIAL:

E. S. ADAMS,

Major General,

The Adjutant General.

DISTRIBUTION:

R and H (5); Bn and L (3).

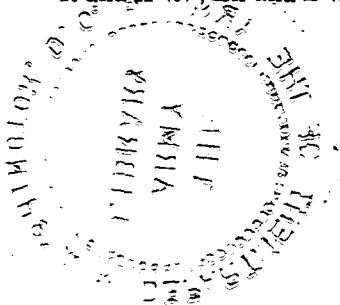

0
423.3
FM 27-15

TABLE OF CONTENTS

CHAPTER 1. MILITARY AID TO CIVIL AUTHORITIES.	Paragraph	Page
Section I. General.		
Scope of manual.....	1	1
Responsibility of civil authorities.....	2	1
Authority for use of Federal troops.....	3	2
II. Limitations and authorizations.		
Statutory limitations.....	4	3
Constitutional and statutory authorizations.....	5	4
III. Procedure.		
Procedure contained in Army Regulations.....	6	6
Application for troops.....	7	6
Initial action by local commander.....	8	6
Administration.....	9	7
Writ of habeas corpus.....	10	8
IV. Martial law.		
Definition.....	11	9
Legal authority.....	12	9
Proclamation.....	13	10
Legal effects.....	14	10
Comparison between martial law and occasions of military aid.....	15	10
V. Liability of military personnel under civil laws.		
General.....	16	11
Palpable illegality of the order.....	17	11
Excessive or malicious violence.....	18	11
Right to trial by Federal Court.....	19	12
Rule of conduct.....	20	12
CHAPTER 2. EMPLOYMENT OF TROOPS IN CIVIL DISTURBANCES.		
Section I. General.		
General.....	21	13
II. Troops and equipment.		
Troops.....	22	13
Equipment.....	23	15
Weapons and ammunition for ground troops.....	24	15
Transportation.....	25	15
Miscellaneous supplies.....	26	15
III. Movement of troops.		
Methods of transportation.....	27	15
Precautions to be taken before starting.....	28	15
Precautions to be taken en route.....	29	16
Precautions to be taken at destination.....	30	16

TABLE OF CONTENTS

CHAPTER 2, EMPLOYMENT OF TROOPS IN CIVIL DISTURBANCES—Continued.		Paragraph	Page
Section IV. Tactics against crowds and mobs.			
Variation in requirements of the situation.....	31		17
Distinction between crowds and mobs.....	32		17
Crowd tactics.....	33		18
Mob tactics.....	34		18
Formation.....	35		19
Attack of a building.....	36		20
Barricades.....	37		21
Defense of localities.....	38		21
Use of scout cars.....	39		21
Use of mounted men.....	40		22
Use of tanks.....	41		22
V. Offensive action against a city.			
General.....	42		22
Methods of attack.....	43		23
Marching through city streets.....	44		23
Mopping up.....	45		24
Sniping.....	46		24
Restoring and sustaining civil government.....	47		24
VI. Occupation of a center of domestic disturbances.			
General.....	48		25
Information furnished military commander.....	49		25
Duties of military commander.....	50		26
Communications.....	51		28
Intelligence service.....	52		28
Reconnaissance.....	53		29
Airplanes.....	54		29
Traffic control.....	55		29
Conduct toward civilians.....	56		29
Private property.....	57		30
Patrols.....	58		30
Exercise of police functions by soldiers.....	59		30
CHAPTER 3. USE OF CHEMICALS IN DOMESTIC DISTURBANCES.			
Section I. General.			
Purpose.....	60		32
Definitions.....	61		32
Advantages of chemical agents.....	62		33
II. Suitable chemical agents.			
Classification.....	63		33
Relative effectiveness.....	64		33
III. Munitions.			
General.....	65		34
Markings.....	66		35
Hand grenade.....	67		36
Rifle grenade, tear.....	68		37
Irritant candle.....	69		39
Smoke pot.....	70		41

TABLE OF CONTENTS

CHAPTER 3. USE OF CHEMICALS IN DOMESTIC DISTURBANCES.—Continued.		Paragraph	Page
Section IV. Tactical employment.			
General	-----	71	42
Technique of cloud travel	-----	72	42
Governing tactical factors	-----	73	44
Practical application	-----	74	45
V. Protection.			
Military personnel	-----	75	47
Rioters	-----	76	47
VI. Problems, examples, rules, and tables.			
Illustrative problems	-----	77	48
1. Riot in penal institution	-----		48
2. Mob determined upon lynching prisoner	-----		51
3. Barricade in open country, with rioters provided with commercial gas mask protection	-----		52
4. Barricaded criminals in center of population	-----		57
5. Disorderly street gatherings	-----		59
Examples illustrating use of chemicals	-----	78	63
General rules on employment of chemical munitions	-----	79	68
Tables	-----	80	70
I. Characteristics of chemical agents for use in civil disturbances	-----		70
II. Statistics, chemical grenades, candles, and smoke pots	-----		71
III. Minimum ammunition requirements for smoke and gas clouds	-----		72
APPENDIX, Statutory limitations and authorizations	-----		75
INDEX	-----		79



BASIC FIELD MANUAL

MILITARY LAW

DOMESTIC DISTURBANCES

(This pamphlet supersedes Basic Field Manual, volume VII, part three, March 1, 1936)

CHAPTER 1

MILITARY AID TO CIVIL AUTHORITIES

	Paragraphs
SECTION I. General.....	1-3
II. Limitations and authorizations	4-5
III. Procedure.....	6-10
IV. Martial law	11-15
V. Liability of military personnel under civil laws....	16-20

SECTION I

GENERAL

■ 1. SCOPE OF MANUAL.—This manual is limited to a brief presentation of such of the principles of the law governing the employment of Federal military forces in aid of the civil authorities as the troops in camp or field, in time of war or domestic disturbance, ordinarily may have need to know and apply. The calling of State troops for use within the State in aid of the civil authorities is governed by the laws of the State concerned, and the limitations and restrictions as to their authority to act under such State call must depend on the laws of the State. However the general principles and methods of employment of troops and matériel as stated in this manual apply equally to any armed force used for this purpose.

■ 2. RESPONSIBILITY OF CIVIL AUTHORITIES.—In time of war in domestic territory (outside of such part of the theater of operations as may be under martial law), the maintenance of law and order continues, as at other times, to be pri-

marily the function and responsibility of the civil authorities, and such authorities may invoke military aid under the same general procedures as at other times.

■ 3. AUTHORITY FOR USE OF FEDERAL TROOPS.—*a. The President.*—Federal military forces employed in aid of State or Federal civil authorities act by authority and under the direction and control of the President as Commander in Chief. The President derives his authority from the Constitution and laws of the United States. Commanding officers and their subordinates, acting in aid of the civil authorities, ascertain their missions and the scope of their powers, duties, and responsibilities from the orders and instructions issued through military channels by the President or under his authority, either specially, with relation to the particular occasion in question, or generally, in the form of Army Regulations or other official publications.

b. Local commanders and troops.—Except in the case of a local commander called upon to act in an emergency upon his own initiative pursuant to Army Regulations (see par. 8), commanding officers and their subordinates are not usually concerned with the basic legal authority for the employment of troops directed. That responsibility is borne by the authority initiating the order, usually the President, or the Secretary of War or military superior acting for and by authority of the President.

c. Local emergencies.—In an exceptional emergency where a local commander must decide initially for himself whether to employ troops of his command in aid of the civil authorities, he is responsible for the legality of his orders and the action taken thereunder until higher authority assumes control. In such cases the authority of the local commander is that delegated to him by Army Regulations or other official instructions in force, subject where to he may cause troops of his command to perform such and only such duties, appropriate to the occasion, as are necessary to protect Government property or the mails from damage or interference, Government officials from violence, or, in time of war, vital centers and industries from sabotage. Military intervention in case of public disaster is without statutory sanction.

Nevertheless, commanding officers who have been confronted with emergency situations caused by floods, earthquakes, fires, and other like disasters have in the past taken prompt and vigorous action to the fullest extent permitted by the men and material at their disposal, in order to relieve suffering; and their action has been supported by their superiors and by public opinion. Military commanders, confronted by such situations in the future, who act likewise, may reasonably anticipate that their action will be similarly supported. (See AR 170-10.)

SECTION II

LIMITATIONS AND AUTHORIZATIONS

■ 4. STATUTORY LIMITATIONS.—*a. Posse Comitatus Act.*—The use of Federal troops is limited by the so-called "Posse Comitatus Act," providing in pertinent part as follows:

From and after the passage of this act it shall not be lawful to employ any part of the Army of the United States, as a posse comitatus, or otherwise, for the purpose of executing the laws, except in such cases and under such circumstances as such employment of said force may be expressly authorized by the Constitution or by act of Congress; * * * and any person wilfully violating the provisions of this section shall be deemed guilty of a misdemeanor and on conviction thereof shall be punished by fine not exceeding ten thousand dollars or imprisonment not exceeding two years or both such fine and imprisonment. Sec. 15, act of June 18, 1878 (20 Stat. 152; 10 U. S. C. 15; M. L., 1939, sec. 480).

NOTE.—This statute has no application in Alaska. *Sec. 29, act of June 6, 1900 (31 Stat. 330; 10 U. S. C. 15; M. L., 1939, sec. 480).*

(1) *Exceptions to Posse Comitatus Act.*—It will be noted that the statute quoted in *a* above applies only to the use of the Army "for the purpose of executing the laws." It has been held that this prohibition does not extend to the employment of Federal troops where the main purpose is the protection of Federal property or Federal agencies, even though the action contemplated may and usually does serve incidentally to facilitate execution of the laws (Dig. Ops. J. A. G., 1928, p. 37). On the same principle the prohibition of the act does not apply to the use of Federal troops where

the main object is, for example, the protection of Federal officials against violence or forcible obstruction of their functions (but not to aid them in serving process), or in time of war to guard vital centers, industries, and installations.

(2) *Effect of Posse Comitatus Act.*—In every case where the main purpose of the use of the troops is to aid the civil authorities in the execution of the laws, there must be (except in Alaska or other places where the act is not in force) the express authority indicated by the Posse Comitatus Act.

b. Presence of troops at places of election.—Every officer of the Army or Navy, or other person in the civil, military, or naval service of the United States, who orders, brings, keeps, or has under his authority or control any troops or armed men at any place where a general or special election is held in any State, unless such force be necessary to repel armed enemies of the United States, shall be fined not more than five thousand dollars and imprisoned not more than five years. *Sec. 22, act of Mar. 4, 1909 (35 Stat. 1092; 18 U. S. C. 55; M. L., 1939, sec. 794).*

■ 5. CONSTITUTIONAL AND STATUTORY AUTHORIZATIONS.—*a. The Constitution of the United States.*—The United States shall guarantee to every State in this Union a Republican Form of Government, and shall protect each of them against Invasion; and on Application of the Legislature, or of the Executive (when the Legislature cannot be convened) against domestic Violence. *See article IV, section 4.*

The Congress is vested with the power to raise and support armies; to make rules for the government and regulation of the land and naval forces; to provide for calling forth the militia to execute the laws of the Union, suppress insurrections, and repel invasions. *See article I, section 8.*

The President is Commander in Chief of the Army and Navy of the United States and of the militia of the several states when called into the service of the United States, and is obliged to preserve and protect the constitution of the United States as well as to take care that the laws be faithfully executed. *See article II, sections 1, 2, and 3.*

b. Statutory authorizations.—The most important of the Federal statutes expressly authorizing employment of troops

in aid of the civil authorities are stated in substance below with citations to the appendix where appropriate.

(1) *Federal aid for State governments.*—When there is an insurrection against the government of any State, it shall be lawful for the President, upon request of the State, to call forth the militia of other States or to call forth such forces of the Army or Navy as he deems necessary, and use them to suppress the insurrection. (See App., par. 3.)

(2) *Use of military and naval forces to enforce authority of the Federal Government.*—When because of any unlawful opposition against the authority of the Federal Government in any State or Territory the enforcement of the laws of the United States, in the judgment of the President, becomes impracticable, it shall be lawful for the President to call forth the militia of any or all States and any part of the forces of the Army and Navy as he deems necessary and use them to enforce the laws of the United States or to suppress such opposition. (See App., pars. 2 and 4.)

(3) *Denial by State of equal protection of laws.*—When because of any unlawful opposition against the laws of a State, or of the United States, any portion of the people of the State are deprived of equal protection and rights guaranteed by the Constitution and the laws of the United States, it shall be lawful for the President to employ the militia or the land and naval forces of the United States, as he may deem necessary, to suppress such opposition. (See App., par. 5.)

c. Hawaii and Puerto Rico.—In Hawaii (31 Stat. 153; 48 U. S. C. 532), and Puerto Rico (39 Stat. 955; 48 U. S. C. 771), the Governor is expressly authorized by law to call upon local commanders of military and naval forces of the United States to prevent or suppress lawless violence, invasion, insurrection, or rebellion. The continued use of Federal troops under such calls is, however, subject to the decision of the President.

d. Miscellaneous statutes.—Other Federal statutes expressly authorizing the employment of Federal troops in aid of the civil authorities are set forth in AR 500-50. Because of the infrequency of occasion for their application these

statutes are not quoted, and the remainder of this chapter does not necessarily apply to the use of troops under such statutes.

SECTION III

PROCEDURE

■ 6. **PROCEDURE CONTAINED IN ARMY REGULATIONS.**—Provisions for the employment of Federal troops for the enforcement of the laws are set forth in detail in AR 500-50.

■ 7. **APPLICATION FOR TROOPS.**—*a. General.*—Applications for the use of troops will be promptly transmitted to the President, even though the occasion be such that the use of troops is authorized or indicated before the application is acted upon. The occasion, however, may be such as to justify initial action by the President or by a local commander irrespective of any application.

b. Insurrections against State governments.—If the occasion is an insurrection against a State government, and the circumstances do not justify initial action by the President, an application by the State legislature, or when the legislature cannot be convened, by the Governor, is an essential prerequisite to the employment of Federal troops.

c. Disturbances affecting Federal Government.—On such occasions no application from the civil authorities being necessary, the President, subject to R. S. 5300 when applicable, may direct the employment of Federal troops without application from the civil authorities; and in like cases and subject to the conditions indicated herein, a local commander may direct such employment without such applications.

■ 8. **INITIAL ACTION BY LOCAL COMMANDER.**—In case of sudden and unexpected invasion, insurrection, or riot, endangering the public property of the United States, or of attempted or threatened robbery or interruption of the United States mails, or of earthquake, fire, or flood, or other public calamity disrupting the normal processes of government, or other equivalent emergency so imminent as to render it dangerous to await instructions requested through the speediest means of

communication, an officer of the Army may take such action before the receipt of instructions as the circumstances of the case and the law under which he is acting may justify, and will promptly report his action, and the circumstances requiring it, to The Adjutant General, by telegraph or radio if possible, for the information of the President. (AR 500-50.)

■ 9. ADMINISTRATION.—*a. Proclamation commanding insurgents to disperse.*—Whenever, in the judgment of the President, it becomes necessary to use the military forces under paragraph 5*b*, the President shall forthwith, by proclamation, command the insurgents to disperse and retire peaceably to their respective abodes within a limited time. See R. S. 5300 (50 U. S. C. 204; M. L., 1939, sec. 505).

b. Action pending issuance of proclamation.—Whenever the situation is such as to require issuance by the President of the proclamation prescribed by R. S. 5300, and action is initiated by a local commander, the latter must confine such action to defensive measures indicated in paragraph 3*c* until receipt of instructions from higher authority.

c. Command.—(1) In the enforcement of the laws, troops are employed as a part of the military power of the United States and act under the orders of the President as Commander in Chief.

(2) They cannot be directed to act under the orders of any civil officer.

(3) The commanding officers of troops so employed are directly responsible to their military superiors.

(4) Any unlawful or unauthorized act on their part would not be excusable on the ground of an order or request received by them from a marshal or any other civil officer (AR 500-50).

(5) The use of troops should end the moment that the necessity therefor ceases and the normal processes of civil government can be restored. Persons not normally subject to military law, taken into custody by the military forces incident to the use of troops contemplated by these regulations, should be turned over to the civil authorities. Punishment in such cases belongs to the courts of justice and not to the armed forces.

d. Tactics.—(1) Troops employed in aid of the civil authorities are governed by the general regulations of the Army and

apply military tactics in respect to the manner in which they will act to accomplish the desired end.

(2) It is purely a tactical question what use will be made of the weapons with which they are armed and at what stage of the operations any or all will be employed, except that the use of airplanes during domestic disturbances will be limited to reconnaissance and the transportation of personnel or matériel, except where, in any case, specifically directed by the War Department. This tactical question will be decided by the immediate commander of the troops, according to his judgment of the situation. The fire of troops should be withheld until timely warning has been given to the innocent who may be mingled with the mob. Troops must never fire into a crowd unless ordered by their commanding officer, but as soon as sufficient warning has been given to enable the innocent to separate themselves from the guilty, the action of the troops should be governed solely by the tactical consideration involved in the duty they are ordered to perform. The use under these circumstances of chemical agents, such as tear gas, has been found to be an effective and humane means of dispersing a mob. However, troops should make their blows so effective as promptly to suppress all resistance to lawful authority and should stop their attack the moment lawless resistance has ceased. Punishments belongs not to the troops but to the courts of justice.

■ 10. WRIT OF HABEAS CORPUS.—The writ of habeas corpus is an order issued by a judge and addressed to the custodian of a prisoner, directing that such custodian bring the prisoner into the court for judicial determination of the legality of his arrest and detention. The Constitution of the United States provides that the privilege of the writ shall not be suspended, unless when in case of rebellion or invasion the public safety may require it (art. 1, sec. 9). At present, statutory authority for such suspension exists only within Hawaii and Puerto Rico. The status of martial law does not of itself suspend the writ, although in event the civil courts are closed, it is apparent the writ could not issue during the period of such closure. A Federal military officer is bound to obey the writ when issued by a Federal judge, but to such a writ issued by a State court, the officer should make respectful return to the

effect that the prisoner is held by authority of the United States Government. It does not follow that a prisoner arrested and detained by the military authorities under martial law or otherwise in aid of the civil authorities would necessarily be released or turned over to the civil authorities for trial at the hearing of the writ, for the courts usually hold such arrest and detention to be lawful in such situations upon reasonable showing of military necessity, even where no specific crime is charged.

SECTION IV

MARTIAL LAW

■ 11. DEFINITION.—Martial law, often and more accurately termed “martial rule” or “government by martial law,” in its true sense means the temporary government of the civil population through the military forces as necessity may require in domestic territory as distinguished from occupied territory of an enemy recognized as a belligerent.

■ 12. LEGAL AUTHORITY.—Martial rule is not authorized by any express provision of the Constitution or of a Federal statute of general application, but the legal power and right of the President and of military commanders acting under his authority to exercise martial rule in an appropriate case are well established and judicially recognized as being derived by necessary implication from various provisions of the Federal Constitution. Martial rule may properly exist only when and where a condition prevails which amounts to a state of war, either civil or against a foreign enemy, as a result of which, in the particular locality affected, the machinery of the civil government has broken down, and the courts are no longer properly and unobstructedly exercising their jurisdiction. In such a situation the safety of the Army or society demands, for the time being, a substitute for the deposed civil authority; and the military, being the only authority left, must govern until the civil government can be restored to the proper exercise of its functions. Thus martial rule is born of necessity; and it ceases when the necessity ends. The Organic Acts of Hawaii and Puerto Rico authorize a declaration of martial law by the governor.

■ 13. **PROCLAMATION.**—A proclamation of martial rule is a declaration that a condition of martial rule exists and is recognized. The proclamation does not create the condition, but rather announces an already existing condition brought about by acts of the enemy. A proclamation is not legally necessary for the exercise of martial rule, but is generally desirable as the most practical means of informing all concerned of the existence of a state of martial rule, of the boundaries of the area affected, and of the special regulations and restrictions that will be enforced by the troops. Such a proclamation is issued by the President or by the local commander at the express direction of the President. With our present means of nearly instantaneous communication, it is almost inconceivable that a situation could arise which would justify a local commander in proclaiming martial rule without the President's express direction.

■ 14. **LEGAL EFFECTS.**—In areas under martial law maintained by Federal troops, the civil and criminal laws continue in force, except insofar as their actual enforcement may be suspended for the time being by inability of the civil authorities to function, or in specific particulars, as a matter of military necessity, by order of the President or of the military commander acting by authority of the President. The legal authority of the President, in such case and within the area affected, to cause the arrest by military agencies of civilians charged with offenses against the laws of the land or against the special rules and regulations promulgated by the military commander by authority of the President, and their detention in military custody until they can safely be released or delivered to appropriate civil authorities for trial, is unquestioned. Trial and punishment of such persons by military tribunals of competent jurisdiction are also permissible. However, this action should be taken only in cases of extreme necessity as the duty of the military is not to punish civil offenders but to prevent disorder, and this can ordinarily be accomplished by holding the prisoner until he can be safely released for trial by the civil authorities.

■ 15. **COMPARISON BETWEEN MARTIAL LAW AND OCCASIONS OF MILITARY AID.**—The status of martial rule differs from that

arising upon the employment of troops in aid of civil authorities in other circumstances only in respect of the greater degree of military control exercised in the former case. With relation to specific missions assigned to troops under martial rule, their legal powers, duties, and liabilities are fundamentally the same as in carrying out missions in aid of the civil authorities in the absence of a status of martial rule. The latter status may or may not arise in connection with any particular occasion for the use of troops, depending upon the nature and extent of the emergency. It should be noted that martial law is rarely invoked and that history shows its use in only a few instances, the normal use of troops being in aid of civil authorities. The fundamental mission of troops employed in domestic disturbances is to restore order and permit the normal functioning of the civil authorities and institutions.

SECTION V

LIABILITY OF MILITARY PERSONNEL UNDER CIVIL LAWS

■ 16. **GENERAL.**—When troops are being employed in domestic territory, even when martial rule prevails, the acts of the individual officer and enlisted man are subject to review by the civil courts in actions for damages or in criminal proceedings.

■ 17. **PALPABLE ILLEGALITY OF THE ORDER.**—Ordinarily a military subordinate incurs no liability for an act done in good faith in obedience to orders from superior authority, but the order is no defense if its illegality is so palpable as to be immediately apparent to a person of average intelligence.

■ 18. **EXCESSIVE OR MALICIOUS VIOLENCE.**—Troops have a right to use such force as is necessary to carry out their orders and to accomplish their military mission, and individual officers and men are not liable for honest errors of judgment in determining how much force is necessary in a given emergency, but unnecessary violence applied with malice or recklessness may subject the responsible individual to liability, civil or criminal, or both.

■ 19. RIGHT TO TRIAL BY FEDERAL COURT.—When any civil or criminal prosecution is commenced in any court of a State against any officer, soldier, or other person in the military service of the United States on account of any act done under color of his office or status, or in respect to which he claims any right, title, or authority under any law of the United States respecting the military forces thereof, or under the law of war, such suit or prosecution may at any time before the trial or final hearing thereof be removed for trial into the District Court of the United States in the district where the same is pending in the manner prescribed in section 33 of the act entitled “An act to codify, revise, and amend the laws relating to the judiciary,” approved March 3, 1911, and the cause shall thereupon be entered on the docket of said district court and shall proceed therein as if the cause had been originally commenced in said district court and the same proceedings had been taken in such suit or prosecution in said district court as shall have been had therein in said State court prior to its removal, and said district court shall have full power to hear and determine said cause. *A. W. 117; 10: U. S. C. 1589.*

■ 20. RULE OF CONDUCT.—Unhesitating obedience to orders of military superiors is, at all times, the first duty of the soldier. Civil as well as military courts discharge military subordinates from legal liability of any kind for acts done in obedience to military orders, except where the order is clearly illegal or where unnecessary force or malicious violence is used. Therefore, officers and men receiving orders from their military superiors, not palpably illegal, directing action in aid of the civil power, must presume the legality of such orders and proceed promptly to carry them out, each subordinate, with relation to matters within his own discretion, being careful not to exceed his authority, not to apply malicious or unnecessary violence, and not to do or require anything to be done in violation of the law, or of the regulations or orders of higher authority.

CHAPTER 2

EMPLOYMENT OF TROOPS IN CIVIL DISTURBANCES

	Paragraphs
SECTION I. General.....	21
II. Troops and equipment.....	22-26
III. Movement of troops.....	27-30
IV. Tactics against crowds and mobs.....	31-41
V. Offensive action against a city.....	42-47
VI. Occupation of a center of domestic disturbances..	48-59

SECTION I

GENERAL

■ 21. **GENERAL.**—*a.* From the adoption of the Constitution to the present time Federal troops have been used in the suppression of domestic disturbances on more than a hundred occasions. Such use is expressly provided for by the Constitution, and all arms and services should be familiar with the law and the approved procedure and practice in situations requiring Federal aid in sustaining the civil authorities, Federal and State.

b. Troops called into action against a mob forcibly resisting or obstructing the execution of the laws of the United States or attempting to destroy property belonging to or under the protection of the United States are governed by the regulations of the Army and apply military tactics to accomplish the desired end.

c. The manner of employment of weapons with which troops are armed, and the stage of operations at which certain types of action will be applicable, are tactical questions and therefore decided by the commander of troops.

SECTION II

TROOPS AND EQUIPMENT

■ 22. **TROOPS.**—Which combat arms are appropriate for use in domestic disturbances depends to a great extent on

the nature of the action expected. In general, however, the following is applicable:

a. Infantry.—Infantry usually constitutes the major part of any command employed in suppressing a domestic disturbance.

b. Cavalry.—Because of the moral effect of an armed man on horseback and the mobility of its horse and mechanized elements, Cavalry constitutes a valuable and effective adjunct to any command employed on riot duty. The great value of horse cavalry in riot duty lies in its ability to disperse rioters by the use of its horses, as weapons of shock, without the necessity of taking life by the use of firearms.

c. Armored units.—The mobility, armor, and armament of armored vehicles make them particularly effective weapons in the suppression of domestic disturbances. They are capable of crushing street barricades and obstacles, and their armor renders them invulnerable to small-arms fire and missiles. The psychological and moral effect they create is of great value in intimidating unlawful crowds or mobs.

d. Artillery.—When it can be foreseen that serious military operations will be required to restore order, Field Artillery should be included as a part of the command.

e. Aviation.—Airplanes may be used for the purposes of reconnaissance, dropping proclamations, orders, or messages over positions or portions of a city occupied by rioters; and for photographing the area to be operated over in order to enable the troops to familiarize themselves with the principal landmarks and barricades of the routes to be passed over. During the attack, airplanes may be used for the purpose of keeping rioters off roofs by means of machine guns or other automatic weapon fire and, in conjunction with other arms, by dropping tear gas, high explosive, or personnel bombs. Aircraft may also be used for the purpose of directing the movements of armored or other ground forces, and under appropriate circumstances for the purpose of transporting parachute troops and/or air landing troops.

f. Engineers.—The employment of Engineers will have particular application in the planning and execution of

barrier and obstacle missions, and in the removal and passage of all types of street obstacles.

■ 23. **EQUIPMENT.**—The equipment required will not differ materially from that of ordinary field service. The character of the service expected, the season of the year, and other conditions will indicate the desirable modifications.

■ 24. **WEAPONS AND AMMUNITION FOR GROUND TROOPS.**—In addition to weapons with which normally armed, shotguns, using charges of buckshot, are appropriate for a portion of the command. An adequate supply of hand grenades is essential. Small-arms ammunition should include a supply of guard cartridges, caliber .30. For chemical munitions see chapter 3.

■ 25. **TRANSPORTATION.**—Motor vehicles are necessary for supply, transportation of patrols and messengers, and for the rapid transportation of troop units. Shortage of military motor transport should be remedied by the procurement of additional vehicles from civil sources.

■ 26. **MISCELLANEOUS SUPPLIES.**—These will normally include such items as riot sticks, axes, picks, sledge hammers, crow-bars, and rope.

SECTION III

MOVEMENT OF TROOPS

■ 27. **METHODS OF TRANSPORTATION.**—Troops are moved to the scene of disturbance by railway trains, trolley cars, motor or water transport, airplanes, or by marching, depending upon the distance, the availability of transportation facilities, and imminence of the danger.

■ 28. **PRECAUTIONS TO BE TAKEN BEFORE STARTING.**—*a.* If troops travel by rail, special trains should be provided so as to avoid subjecting civilian passengers to danger from possible measures that might be taken against the troops.

b. If there is danger of interference with the troops at the entraining point, guards should be so posted as to keep all but the troops and necessary railway personnel away from the

vicinity. It may be advisable to move the train to the edge of a city or town and entrain there. After entering the cars, details should be posted so as to cover with fire the approaches to the train.

■ 29. PRECAUTIONS TO BE TAKEN EN ROUTE.—Railroad trains should be run at reduced speed over parts of the track where interruptions may be expected. If there is reason to suspect that any explosive has been placed along the track, it may be advisable to push several flat cars ahead of the engine. The commanding officer of the troops may assume control of the train only when the military situation demands that he do so, but until the necessity for doing so arises he should leave its operation to its crew.

■ 30. PRECAUTIONS TO BE TAKEN AT DESTINATION.—*a.* Upon reaching the vicinity of the disturbance, it will be necessary to proceed still more cautiously. It will usually be advisable to detrain on the outskirts of a city and march the remaining distance. Detraining points should be so selected that the troops will be reasonably free from interference while detraining. The point selected should also be such as will least interfere with regular traffic or with troop trains which are to follow.

b. The troops first to arrive at the area are so disposed as to cover the detraining of later arrivals. Such protection will be needed, particularly by units which are to arrive by train, motor, or water transport, or by flying. At once upon detraining, debarking, or debussing, the troops should take up such formation as will enable them best to protect themselves against attack. Guards should be posted in the immediate vicinity to keep curious crowds and possible bomb throwers at a safe distance, but this alone will not constitute sufficient protection. Outposts should be extended in the general direction of the disturbance far enough to keep the main body of troops reasonably safe from small-arms fire from rioters.

c. Upon leaving the train or transport, troops should take with them such personal equipment and rations as may be needed for at least 24 hours.

SECTION IV

TACTICS AGAINST CROWDS AND MOBS

■ 31. VARIATION IN REQUIREMENTS OF THE SITUATION.—Federal troops may be used on occasions varying from those in which the mere presence of a small force will be sufficient to accomplish the object sought, to those reaching a magnitude requiring serious military operations. The requirements will therefore vary within such wide limits that any rules laid down must be very general.

■ 32. DISTINCTION BETWEEN CROWDS AND MOBS.—*a.* A *crowd* is a large number of persons in a close body, but without organization. A *mob* is a riotous crowd. A crowd at all on mischief bent requires only a leader to convert it into a mob. Requiring a crowd to move on and break up may avoid dealing with a mob later.

b. A crowd assembled for an unlawful purpose is cowardly. It hesitates to commit itself to a course of unrestrained violence even though some of its members may be guilty of violent acts when they think they have a good chance to escape. It may be noisy and threatening, and if left to its own devices is very likely to commit assaults and depredations which will excite it to the mob pitch; but just as long as the crowd is kept well in hand, its collective cowardice remains its most striking feature. The subtle change by which a crowd becomes a mob is a thing never forgotten by anyone who has seen it. An apparent weakening of the forces holding a crowd in check, even though it be but momentary, may suffice to bring about the transformation: a single piece of audacious violence successfully carried through; 2 minutes' harangue by a fiery leader; or the appearance on the street of a conspicuous and hated figure. It is the business of the officials, civil and military, to see that this change does not take place, for the formation of a mob means bloodshed before order is restored.

c. A crowd is a group or number of separate groups, which is or may be disorderly and inclined to violence, but which has not as yet lost its collective sense of reason. A mob, on the other hand, is distinguished by the fact that, under the

stimulus of intense excitement, its members have actually lost all sense of reason or all respect for law and can only be brought to their senses by an overpowering demonstration of force.

■ 33. CROWD TACTICS.—*a.* As a rule, weapons fire should be used against a crowd only as a last resort.

b. For psychological effect, it should be evident to the crowd that there is a commander, that he has a plan, that he has the courage to act vigorously, and that he intends to use whatever force is necessary.

c. Having broken up the crowd, it is necessary to keep it moving. Patrols should be detailed to follow it up and prevent small groups from collecting again. If any person or persons stand out as prospective leaders and seem to be trying to excite the crowd, those persons should be arrested.

■ 34. MOB TACTICS.—*a.* The methods to be employed against mobs differ from those required against crowds. Less dispersion of forces is allowed, more force must be used, and troops must rely on weapons.

b. In cases where military force is used for the protection of Government property or instrumentalities, the military commander who does not command the mob to disperse and allow sufficient time for it to do so before taking life will be derelict in his duty. A mob should not be harangued, or bullied, or bluffed, and above all it should not be threatened or dared.

c. A mob usually should be attacked on one flank, depending upon the direction in which it is desired to drive it. When those in front would like to retreat but because of the pressure from behind are unable to do so, it should be attacked from the rear.

d. When resort is had to rifle fire, the aim should be low so as to prevent shots going over the heads of the mob and injuring innocent persons who cannot get away. The number of rifles used in the firing should be no greater than is absolutely necessary. If there is firing from the rear of the mob, a few marksmen should be so placed as to be able to return the fire. A few good marksmen should be detailed to fire on windows or roofs from which firing comes or from

which missiles are thrown. Care should always be taken to avoid firing into a group of innocent persons from which some rioter has fired.

e. In combating a mob bent on violence, blank cartridges should not be used, nor should a volley be fired over the head of rioters even if there is little danger of hurting persons in rear. Such things will be regarded as an admission of weakness or as an attempt to bluff and may do much more harm than good.

f. Bayonets are effective when used against rioters who are able to retreat, but they should not be used against men who are prevented by those behind from retreating even if they wished to do so.

g. The employment of infantry supporting weapons is necessary only when mob action has assumed serious proportions. In such case machine-gun units are assigned a place in the formation where they are protected by rifle units, and from which they can readily go into action. Mortar units and 37-mm gun units are usually held in reserve until need for their use is indicated.

h. A mobile reserve should always be held ready for use.

■ 35. FORMATION.—*a.* If it becomes necessary to charge a mob or move against it, the formation taken will depend somewhat upon the direction in which it is desired to drive the mob.

b. The following formations are suggested:

(1) Troops marching in parallel columns, heads of columns abreast.



In this case a mob should be driven directly in front of the troops with a chance for them to disperse to the flanks.

(2) Troops marching in parallel columns with the columns in echelon.

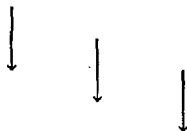

In this case the mob will retreat in an oblique direction from that of the march of the troops, the direction being away from the most advanced column. The formation has the advantage of enabling the more advanced columns to assist the others by flanking movements. In this case one flank will require stronger protection than the other.

(3) Troops marching in parallel columns, those columns on each side of the center being echeloned to the rear so as to form a wedge.

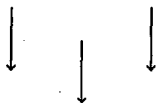

This formation has the effect of dividing the mob into two parts and may be of advantage when it is desired to handle the parts separately. It may be that the mob will thus be forced out into the open where the troops may attack from several directions at the same time.

(4) Any formation which permits the troops to take the mob in flank and rear is usually a desirable one. When it is remembered that being fired into from a flank or from the rear is trying to the morale of the best-disciplined troops, it readily will be appreciated that its demoralizing effect on a mob will be many times multiplied.

■ 36. ATTACK OF A BUILDING.—*a.* A house occupied by rioters may be avoided if it is occupied only as a refuge and is so situated as not to interfere with the operations of the troops. If its occupancy menaces the marching column or interferes with the communications of the troops, or threatens their rear, and it is not desirable to reduce it at once, it may be isolated and dealt with later. It may be attacked if any tactical advantage will accrue to the troops. As a rule direct attack is to be avoided. Artillery, 37-mm guns, infantry mortars, dynamite, grenades, or chemicals may be used against it, or if it is some distance away from other houses it may be set on fire.

b. If the house is one of a block of about the same height, it may be attacked from the roof of an adjoining house. In this case, chemical grenades may be dropped down the chim-

neys, or a skylight may be blown in and grenades used to clear the rooms below. The attack of a house from the top down is much easier than from the bottom up. After securing an entrance, there must be no pause in the progress from room to room until the building is cleared.

■ 37. BARRICADES.—If necessary for the troops to construct barricades, they must be made of any material available and must be constructed to meet any fire that may be brought against them. If the mob has halted behind a barricade, tanks, artillery, 37-mm guns, infantry mortars, or grenades should be used against it. If the barricades can be attacked from the flank or from above, the rioters will soon be forced to retreat. It may be that a foothold can be secured at night when a lack of discipline has caused the barricade to be inefficiently guarded.

■ 38. DEFENSE OF LOCALITIES.—*a.* As a general rule, troops occupy lightly the points to be watched while strong reserves are stationed centrally within easy supporting distance of the smaller detachments.

b. Bridges, trestles, power houses, reservoirs, and similar critical points must be closely guarded, for a single individual might work his way up to a point where he could plant a charge of explosives and, unaided, wreck the plant. The guard may be much smaller if the approaches can be well lighted. The value of plenty of light as an aid to the guard cannot be overestimated.

■ 39. USE OF SCOUT CARS.—*a.* Scout cars constitute valuable means for the suppression or prevention of riots, due to their ability to transport fire power quickly from one location to another and the protection afforded the crew by their armor. By cruising up and down the streets of the city, they can effectively prevent the formation of mobs; or in case mobs have already formed, the cars are equally effective in breaking up and dispersing mobs, and in keeping the rioters on the move. In the employment of scout cars which have no turrets, caution should be exercised to prevent their entering areas or localities where missiles can be hurled into the cars from above. The machine guns, submachine guns, rifles, and

pistols with which the cars are armed are always ready for instant use.

b. When scout cars are used in conjunction with troops making an attack against a mob of rioters, cars are of most assistance to the troops if used to attack the flank or rear of the mob and to drive the rioters in the desired direction. When scout cars are used for patrolling the streets, a top shield should be improvised to protect the crew from snipers firing from windows or the roofs of buildings.

■ 40. USE OF MOUNTED MEN.—*a.* The moral effect created by mounted men is great even though no charge is made. A compact group or several compact groups of horsemen moving against a mob have a greater effect than an equal number of foot troops would have. The horsemen can be seen by those in rear as well as by those in front, which will tend toward breaking up or dispersing the mob.

b. Well-trained horses are a desirable, but not necessarily a controlling, feature. Horses have a tendency to stick together, and if Cavalry is employed in a mass group, the question of being specially trained is not so important.

c. A cavalry charge against a crowd will produce results much more quickly than against a mob.

■ 41. USE OF TANKS.—Tanks will be employed in the same manner and for the same general purpose as employed on the field of battle, and when street barricades are to be reduced, before an advance may continue, are indispensable.

SECTION V

OFFENSIVE ACTION AGAINST A CITY

■ 42. GENERAL.—*a.* The manner of attacking a city held by any organized force will not differ materially from the attack of a city held by hostile troops in time of war, except that the loose organization and lack of discipline among the defenders, and the necessity of preserving human lives and property to the fullest extent possible, will somewhat modify the tactics to be employed.

b. Troops will be disposed with the object of—

(1) Securing possession of as much of the city as possible at once;

(2) Driving the mob into or through the districts of the city where looting is the least profitable and where destruction of property incident to military operations will be reduced to a minimum and preferably fall on the rioters or the class of people composing the rioters;

(3) Securing possession of sensitive and strategic points within the city, such as business or transportation or manufacturing centers, especially those most likely to be attacked by the mobs;

(4) Taking possession of Federal property, Government buildings, banks, and post offices.

c. It should always be remembered that where the construction of buildings is largely of wood, care must be exercised to avoid a general conflagration.

■ 43. METHODS OF ATTACK.—*a.* It may be necessary to attack outlying points which have been prepared for defense. In such case, the attack will not differ materially from the attack of a similar place in time of war.

b. When it is necessary to attack the city itself, it may be of advantage to have the attacking columns enter the city from different directions and converge toward the section from which it is desired to drive the rioters.

c. The point or points from which the attack is to be initiated should, when possible, be so selected that the rioters will not be driven past a reservoir, pumping plant, or electric light plant which they might destroy as they retreat. It usually is best to drive them out into the open and away from their source of supplies.

d. It may be possible in some cases to surround a city and starve it into submission. This is rather a slow process, and gives rise to great destruction of property, and brings undue hardship to the innocent, including women and children. Also, the force required would be large enough to take the city by assault.

e. It may be possible to force the evacuation of a city by shutting off the supply of water and light, but that again involves undue hardship on the innocent and invites destruction of the city by fire.

■ 44. MARCHING THROUGH CITY STREETS.—*a.* Marching through main city streets flanked by high buildings, or

through streets filled with people, generally should be avoided.

b. When necessary to march through such streets, an advance guard formation must be taken up. It may be well to have a squad march in single file at 2 or 3 paces' distance on the sidewalk on one side of the street, while another squad similarly disposed marches on the opposite side of the street. The members of these squads watch the windows and roofs of buildings on the opposite side of the street, and designated individuals fire on persons attacking or threatening the troops. Upon reaching street corners, a pause should be made until flanking parties on parallel streets have reached the same cross street as the leading element of the main column.

■ 45. MOPPING UP.—*a.* Having taken the city, it will be necessary to take measures for overcoming any remaining resistance and for mopping up.

b. In some cases it will be necessary to make a house-to-house search for arms, or for the purpose of arresting the male inhabitants.

c. Mopping-up or searching parties will be sent through the houses on each side of the street, and it may be necessary for such parties to enter some of these houses through breaches made in connecting walls.

d. If houses are not connected, it may be best for parties to approach rapidly from different directions at the same time, while fire is being brought to bear on windows.

■ 46. SNIPING.—This class of firing may be looked for especially when passing through cities where individuals are accustomed to keeping firearms in their homes. Whenever it is possible to do so, selected marksmen should open fire on snipers. When a sniper is caught, he should be held for action by the civil authorities.

■ 47. RESTORING AND SUSTAINING CIVIL GOVERNMENT.—*a* The proper civil officials of the city government should be countenanced and sustained as soon as possible after entering the city. At first it usually will be necessary for the military commander to establish guards and control the area much as he would a military camp or post. The restored civil offi-

cials, or those appointed by proper civil authority, should be afforded the necessary military protection and force to enable them to carry on the city government. The necessity for this support will grow less and less until finally it may be withdrawn entirely.

b. The establishment of military government in the city after taking it over would be very rare indeed. It will seldom be necessary for the military commander to concern himself with questions of taxes, finance, and improvements, which should be left in the hands of the civil government. It may be necessary, however, for him to provide for the immediate repair of the water supply system or other essential utilities.

SECTION VI

OCCUPATION OF A CENTER OF DOMESTIC DISTURBANCES

■ 48. GENERAL.—Cities are the centers where uprisings against law and order usually occur, and it is from these centers that the operations of the lawless element will be conducted.

■ 49. INFORMATION FURNISHED MILITARY COMMANDER.—a. It is important that the military commander be given, in advance of his arrival at the scene of the disturbance, all the information possible concerning the conditions that may confront him in the execution of his task, in order that he may intelligently estimate the situation and formulate tentative plans for the disposition of his troops and for organizing them into a homogeneous command with a headquarters and staff such as will facilitate the accomplishment of his mission. This information will include such monographs, studies, maps, and other information as may be available.

b. A well-informed representative of the civil authorities should meet the military commander upon arrival and give him such additional information as may be available and necessary for the preliminary disposition of the troops. This should include information of the sections where disturbances are most likely to occur, sections where troops may be quar-

tered, and, in general, the action that is to be expected from the lawless element, especially whether or not the coming of troops would be the signal for more violent outbreaks.

c. The military commander will thus have sufficient information upon which to base his first dispositions and to reach a starting point from which he must learn conditions for himself.

■ 50. DUTIES OF MILITARY COMMANDER.—*a.* In his efforts to understand the situation, the commander must set out at once to gather information which should normally include the following:

(1) (*a.*) Information relative to the lawless elements of population, including their numbers, activities, organization, leaders, places of assembly, methods of operation, equipment, newspapers controlled or influenced by them, their grievances or supposed grievances, previous acts of violence, particular classes of property destroyed, and preparations made by this element for carrying on operations.

(*b.*) Much of this information may be secured from the police department, supplemented by private detective agencies, railroad detectives, agents of the Bureau of Internal Revenue, representatives of the Department of Justice, agents of the Post Office Department, customs agents, county sheriff, and city health officer.

(2) (*a.*) Location of armories, schools, or colleges to which arms have been issued, the means taken to secure the protection of such arms, the names and locations of stores dealing in arms and ammunition, the location of storehouses of explosives, the location of police stations, and the extent to which the local police may be depended upon for loyal support.

(*b.*) This information may be obtained from city officials and the sources mentioned in (1) (*b.*) above.

(3) The location of the headquarters of the American Legion and other local organizations representing law and order. The meeting places, strength, attitude, etc., of the members of these organizations should be ascertained, and a conference with their commanders or leaders should be arranged.

(4) (a) The location of public utilities, including water-works, reservoirs, standpipes, gas and electric lighting plants, power houses, street railways, telephone centrals, telegraph offices, fire stations, wharves, subways, viaducts, bridges, tunnels, roundhouses, railway stations and yards, and public buildings.

(b) The city engineer probably will be able to furnish information regarding the above. He probably will also have maps and plans which may be of use in preparing plans for defense.

(c) The extent to which these utilities should be guarded at once must be determined by the circumstances. The water and lighting systems demand prompt and adequate protection.

(d) So important are water and light, that the citizens should be advised to keep on hand a reserve of water in vessels and should provide themselves with oil and candles to meet emergencies.

(5) The location of supplies of fuel, oil, gasoline, and food-stuffs may be learned from prominent dealers in these commodities. The location of refrigerating plants, packing houses, and manufacturing plants may likewise be learned.

(6) The attitude of the public press must be learned and conferences arranged with newspaper men. They will be a source of much information.

(7) The attitude of the people, both employer and employee classes, must be ascertained. Conferences with leaders of both classes should be held. An early attempt must be made to hold a conference with the leaders of the disturbing element, at which they must be impressed with the idea that the military forces intend to maintain an attitude of fairness and impartiality, but that acts of lawlessness and violence will not be tolerated, and that laws will be enforced and order maintained at all costs.

b. The foregoing information must be recorded systematically so that it may be studied later, and so that it may be corrected and kept up to date. The location of sensitive points should be marked on a map and furnished to the subordinates concerned.

c. In his dealing with the information agencies referred to above, the military commander should avoid discussing such

of his plans as he does not wish made known to the public.

d. In his efforts to put down a disturbance, a commander must resort to means designed to weaken the confidence of the disturbing element in their leaders, and to convince them that ultimately the disturbing element must be unsuccessful. If other means of distribution are not effective or readily available, a series of proclamations or notices may be dropped from airplanes.

■ 51. COMMUNICATIONS.—*a.* Information centers are established throughout the occupied parts of the city. These centers should be so located and the location so announced that intelligence personnel, troops, and civilians who have information of value to report may turn in their reports and have them promptly forwarded to headquarters.

b. Each center is connected by telephone with the message center at headquarters and should also be supplied with at least two motorcycle messenger orderlies.

c. It may be necessary to take over the control of the telephone and telegraph lines or assume control of branch centrals through which the main military communications lead. It may even be necessary to establish military lines between important points, also visual signal stations at commanding points, and to make use of radio.

■ 52. INTELLIGENCE SERVICE.—*a.* It is important that an intelligence service be established as soon after arrival as possible. If the G-2, or officer acting as such, is present during the interviews outlined above, he will have much information with which he can start his work. One of the first steps is to determine what assistance the local police can give.

b. The military operatives may work in connection with the police authorities, in which case the Army officer in charge of intelligence will coordinate the activities of the military agents with those of the civil.

c. It will be best to subdivide the intelligence service into several groups, depending upon the class of information desired and the conditions under which the operatives will have to work. Each group should be under an officer or other reliable chief who will report to G-2. The latter need not come into contact with operatives unless it is necessary that

he obtain more detailed information than can be gathered from the reports, or unless it may be necessary to study the personal equation of an operative.

d. Operatives should be cautioned against discussing their plans, information, or orders with other operatives except in those cases where two or more have been placed on the same duty and each informed of the orders given the other. Some general and unobtrusive signal should be decided upon whereby operatives may, in case of necessity, make known the fact that they are engaged in intelligence service.

e. The chiefs of sections must keep themselves fully informed of the activities of their operatives and must require that reports be made at stated intervals and that such reports include details of time and place and other data which will enable reports to be studied, each in connection with the others.

■ 53. RECONNAISSANCE.—It is essential that officers be sent out early to make reconnaissance of important localities which must be protected and make recommendations for their protection.

■ 54. AIRPLANES.—Airplanes flying low may be of value in discovering fires and in watching for assemblages of rioters. The moral effect of the airplane will be very valuable. Airplanes equipped with machine guns or other automatic weapons may be used against rioters on roofs of buildings or in open spaces. They may be used for bombing in certain cases. Airplanes will be especially valuable to the commander for directing the movements of armored and other ground forces when it is necessary to enter a city under opposition.

■ 55. TRAFFIC CONTROL.—It will usually be necessary to provide for traffic control. Whether it should be handled by civilian or military personnel, or by civilian personnel generally supervised by military personnel, will depend upon the situation.

■ 56. CONDUCT TOWARD CIVILIANS.—The military personnel must treat civilians with courtesy and fairness, and throughout must observe an air of dignified impartiality. Especially must soldiers avoid an overbearing manner or the use of

excess authority. Private property must be scrupulously respected. Soldiers must be cautioned against discussing the military situation with civilians. Soldiers will not accept favors from civilians.

■ 57. PRIVATE PROPERTY.—Such private property as is required for use of the troops may be obtained by purchase. Usually all that is needed may be obtained in this way. Only in the most grave emergencies may supplies needed by the troops be taken against the will of the owner. Those so taken must be paid for in cash at a reasonable price on the spot or as soon thereafter as practicable, and receipts must be given in all cases.

■ 58. PATROLS.—*a.* A system of foot, mounted, and motor patrols must be established so that the necessary areas will be covered. The main reliance will be placed on motor transportation. For the outlying districts, where roads are not good, it may be advisable to use 2 or 3 men on motorcycles. For other patrolling, motor trucks may be used to carry a force of a squad or more. Whatever the conveyance, it should be open and without a top so that men may freely use their weapons if need be. Use might be made of radio-equipped motor cars for roving patrols.

b. Prescribed routes for patrols should be such that at frequent intervals, preferably not regular, patrols will appear in the sections of the city where disturbances are most likely to occur. Patrols will report by telephone at stated times and from designated places. Orders prescribing routes should be sufficiently elastic to permit patrols to make short detours in order better to cover the district. Routes usually need to be modified to suit night conditions.

c. It will usually be well to place all patrolling under one head in each district.

■ 59. EXERCISE OF POLICE FUNCTIONS BY SOLDIERS.—The mission of troops on riot duty is, in general, the suppression of lawless violence. In carrying out that mission they are, subject to the directions of the commander and higher military authority, authorized to take such measures as are necessary. These measures will often include the detention or arrest of

persons. The authority to make such arrests is in nowise based on local law governing arrests; but proceeds, as above indicated, from the duty and coextensive authority to carry out their mission. Troops on riot duty as *troops* have no authority other than as above stated to exercise police functions. Persons arrested may be turned over to civil authorities, or they may be detained by the troops as long as the necessities of the situation require. When their detention by the troops is no longer required by the situation, they will be turned over to the civil authorities or released.

CHAPTER 3

USE OF CHEMICALS IN DOMESTIC DISTURBANCES

	Paragraphs
SECTION I. General.....	60-62
II. Suitable chemical agents.....	63-64
III. Munitions.....	65-70
IV. Tactical employment.....	71-74
V. Protection.....	75-76
VI. Problems, examples, rules, and tables.....	77-80

SECTION I

GENERAL

■ 60. **PURPOSE.**—Officers of the arms of every grade are subject to call to service in the control of civil disturbances, and therefore should make a thorough study of the subject in all its phases. They should know their duties and responsibilities on such missions and should have thought out in advance probable courses of action. After receipt of orders there will be little opportunity for this study. Hesitation in the face of a mob is fatal. Prompt and decisive action is essential. The purpose of this chapter is to furnish officers called out upon riot duty such information as will enable them to use chemical agents effectively in controlling and dispersing mobs.

■ 61. **DEFINITIONS.**—For definitions of chemical agents and their characteristics other than those given below see FM 21-40.

a. Chemical agent.—A substance which by its ordinary and direct chemical action produces a toxic effect, a powerful irritant effect, an obscuring smoke, or an incendiary action is called a chemical agent.

b. Gas.—An agent useful primarily for its physiological effect.

c. Irritant agent.—(1) One whose toxicity in concentrations producible in the field is insufficient to cause death or even seriously to endanger health.

(2) The irritant action of such agents warns of their presence and forces persons exposed to seek protection or

move elsewhere long before a dangerous effect can be produced.

d. Intolerable concentration.—An intolerable concentration is the quantity of agent per unit volume of air required to force masking or to destroy completely the working efficiency of an unmasked observer.

■ 62. ADVANTAGES OF CHEMICAL AGENTS.—The reputation of the Army for strict and impartial enforcement of the law is its chief asset in restoring order when local civil authorities have failed. Once having been called upon in such emergency, the military commander must unhesitatingly take such action as circumstances may dictate in order speedily to break up the mob and prevent its re-formation. If the use of force is necessitated, irritant chemical agents will frequently be more effective than firearms, will produce only temporary and noninjurious physical reactions, and may therefore relieve the responsible officer from the onus of having caused bloodshed.

SECTION II

SUITABLE CHEMICAL AGENTS

■ 63. CLASSIFICATION.—By definition chemical agents may produce a physiological effect, an obscuring smoke, or an incendiary action.

a. Physiological effect.—Of the chemical agents suitable for use in civil disturbances, the most important are substances selected on account of their peculiar nonlethal characteristics from the group producing physiological effect. These are CN (tear gas), DM (adamsite), and CN-DM (a combination of the two). The term "gas" is commonly applied to these agents.

b. Obscuring smoke.—From the group of smoke-producing agents one substance, HC, is also frequently used. While this substance is of particular value in disconcerting a mob, its physiological effect is negligible.

c. Incendiary action.—Incendiary agents are not considered in connection with civil disturbances.

■ 64. RELATIVE EFFECTIVENESS.—*a.* CN is easily dispersed and is promptly effective. When no longer in its presence, however, the irritation of the eyes quickly subsides, and the indi-

vidual is soon able to resume an antagonistic attitude. A desperate, determined man can carry on in the presence of considerable tear gas. This agent, while valuable in dispersing crowds, does not necessarily deter their re-formation in other localities.

b. DM irritates the nose and throat more violently than it does the eyes. It causes headache and nausea, inducing marked physical debility. Like CN, it forces all unprotected persons to quit the area in which it is freed; but its continuing effect is most important. A period of several hours, sometimes a whole day, is required for an individual to recover from the effects of definite exposure to DM. Hence this agent is used when the most severe measures are indicated.

c. CN-DM is a mixture combining the properties of each component agent. It may be considered as DM, possessing a marked eye-irritant effect. Proportionately greater quantities of this compound are required to produce the distinctive results common to each of its components. This dispersion of DM in conjunction with CN is accomplished at some sacrifice of the range attained by DM candles.

d. HC produces quickly a spreading white smoke of much greater obscuring power than released CN or DM. While this smoke has an important psychological value, it cannot be expected to cause direct physical reaction.

SECTION III

MUNITIONS

■ 65. GENERAL.—*a.* The service chemical munitions used in civil disorders have been devised primarily to avoid physical injury while producing positive results. They are not particularly adapted to usage in war. The types described in this section may be considered as representing current rather than ultimate designs.

b. These munitions include grenades, candles, and smoke pots. Grenades are munitions light enough to be thrown by hand or projected from the service rifle. Candles and smoke pots are set in place before lighting. Although rifle grenades have been declared obsolete, a limited number are on hand, and because this munition is valuable for use in domestic disturbances its use is discussed in this manual.

c. Grenades are ignited by automatic fuzes. Candles and smoke pots must be ignited manually. Both are of the "burning" type; once ignited, they depend upon combustion to convert their contents into cloud.

d. The irritant (DM) candle and smoke pot are produced and issued by the Chemical Warfare Service to chemical troops only. All chemical grenades are produced jointly by the Chemical Warfare Service and the Ordnance Department and are issued by the latter. A variety of munitions of a similar nature are produced by civilian manufacturers.

■ 66. MARKINGS.—a. The content of each chemical munition is indicated by stenciling on its surface the symbol of the agent and the class to which it belongs (fig. 1). The grenades



FIGURE 1.—Chemical hand grenade marked to indicate that it contains a nonpersistent irritant.

and candles used in civil disturbances are stenciled: CN Gas, CN-DM Gas, DM Gas, HC Smoke. Smoke pots are stenciled: HC Smoke.

b. Circular striping is used to indicate the persistency of agents filled into chemical munitions. Since the chemical munitions used in civil disturbances all contain agents of non-persistent character, they are marked with single stripes. (Dual stripes are used on other types of chemical munitions to denote persistence in excess of 10 minutes.)

c. Stencils and stripes are alike distinctively colored so that the nature of the munition may be identified at a glance. Red designates irritant gas (CN, CN-DM, DM); yellow designates smoke (HC).

■ 67. HAND GRENADE.—*a. Description.*—This assembly consists of a tin container, a filling of agent, and an igniting fuze. (See fig. 2.)

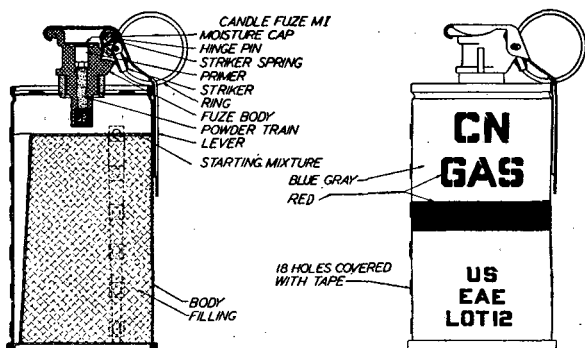

FIGURE 2.—Details of chemical hand grenade.

(1) The container is a cylinder $2\frac{3}{8}$ inches in diameter and $4\frac{1}{2}$ inches long. Its wall is perforated by small holes which are covered by bits of adhesive tape; these are forced loose by internal pressure generated by combustion, thus providing for the emission of gas.

(2) The agent forms into a solid mass within the cylinder, having a top layer of inflammable mixture to precipitate combustion. The agent used may be CN, CN-DM, or HC. However

filled, all hand grenades are identical in appearance except as to marking.

(3) The igniting fuze, inserted in the top of the container, is composed of a firing mechanism and a 2-second fuse. The firing mechanism includes a steel striker which is actuated by a coil spring. When released, the striker hits a primer which sets off a short fuse train; this burns for 2 seconds, then transmits flame to the layer of inflammable mixture, thus igniting the agent.

b. Operation.—The grenade is grasped so that the lever (fig. 2) is held firmly against the container wall by the pressure of the palm of the hand. The safety ring is then used to remove the safety pin. The igniting fuze will now function automatically as soon as the lever is released.

■ 68. RIFLE GRENADE, TEAR.—*a. Description.*—This assembly consists of a steel body, a filling of agent, and an igniting fuze. A rifle rod and a special blank cartridge are used with each grenade. (See fig. 3.)

(1) The body is a barrel-shaped container of thin drawn sheet steel. Eight small holes are punched around the upper body and covered with bits of adhesive tape; these are loosened by internal pressure generated by combustion, thus providing for the emission of gas.

(2) The body is two-thirds filled with a solid mixture containing CN, having a top layer of inflammable mixture to precipitate combustion.

(3) The igniting fuze consists of a firing mechanism and a time fuze assembled into one unit, with a brass top cover. The firing mechanism includes a brass inertia-pellet striker, held in place by a safety pin and also separated from the fuze by a copper spear wire. After the safety pin is pulled, the shock resulting from the discharge of the rifle causes the striker to shear the spear wire and to fall against the primer with sufficient force to detonate it. The primer sets off a piece of Bickford fuze timed to burn 8 seconds. Flame is then transmitted to the layer of inflammable mixture, thus igniting the agent.

(4) The rifle rod is a copper-plated steel rod, 15 inches long, with one end threaded to screw into the base of the grenade.

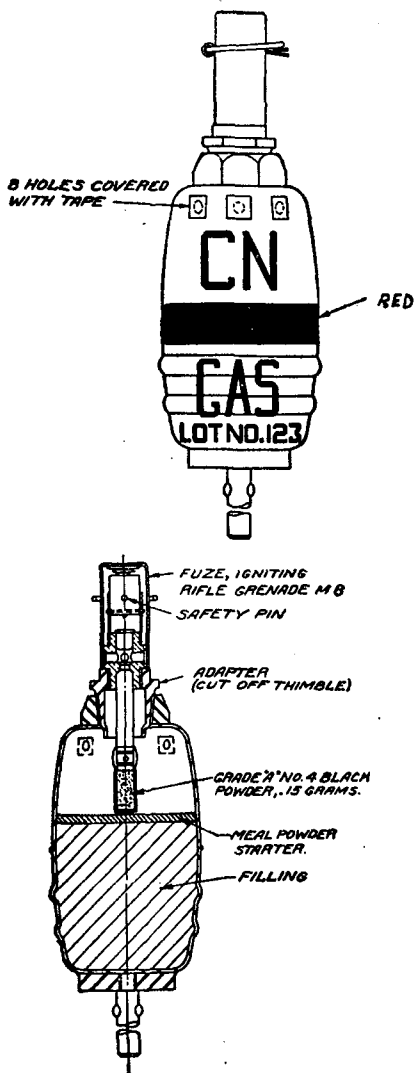

FIGURE 3.—Details of tear gas rifle grenade.

(5) The cartridge is a caliber .30 special blank cartridge which serves as the grenade propellant.

b. Operation.—(1) The rifle rod is screwed tightly into the base of the grenade and is then inserted into the rifle barrel. Care should be taken to see that the rod has not become warped and that it does not bind within the barrel. The safety pin is then pulled; this releases the brass cover from the top of the igniting fuze. The grenade is now armed and will function automatically as the rifle is fired.

(2) In firing, the rifle is invariably supported on the ground or other solid object—never against the shoulder. The trigger should be pulled by the thumb to prevent injury to the hand by excessive recoil. A firing elevation of 45° permits a maximum range of about 265 yards.

(3) Springfield rifles bearing serial numbers greater than 800000 and Rock Island rifles bearing serial numbers greater than 285507, only, are suitable for firing rifle grenades.

■ 69. IRRITANT CANDLE.—*a. Description.*—(1) The candle consists of two cylindrical compartments of sheet steel 7 inches in diameter by $2\frac{7}{8}$ inches high, placed one above the other and bolted together with an external flange. The lower compartment contains a $3\frac{1}{4}$ -pound cake of smokeless powder used as fuel to supply heat. Mounted on the cake is an ignition device consisting of a match head and a phosphorus-coated wire scratcher (fig. 4). The upper compartment contains a 2-pound cake of DM (adamsite).

(2) The candle utilizes the principle of steam distillation to disperse the agent. This is accomplished by passing heat from the burning smokeless powder through a flue into the upper compartment and thence across the surface of the DM. The resulting distillate is carried above a baffle and through a slot into the air where it quickly cools and condenses to form a very finely divided solid.

(3) The complete candle weighs $9\frac{1}{4}$ pounds.

b. Operation.—(1) Remove tapes from the exit slot and from the end of the pull wire. Place the candle on the ground in an upright position, the operator standing upwind with gas exit pointing downwind. Hold candle firmly to the ground, straighten wire loop to a horizontal position, and pull the wire quickly outward until it stops. A hissing sound

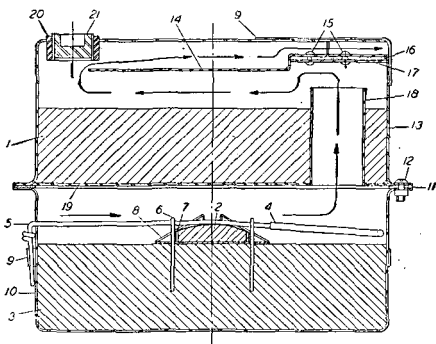

- | | |
|---------------------------|-----------------------------|
| 1. Irritant mixture. | 12. Stove bolt. |
| 2. Match head. | 13. Upper container. |
| 3. Smokeless-powder fuel. | 14. Baffle plate. |
| 4. Scratcher. | 15. Round-head iron rivet. |
| 5. Pull wire. | 16. Insulator. |
| 6. Match head anchor. | 17. Insulator plate. |
| 7. Match head ring. | 18. Vent pipe. |
| 8. Match head plate. | 19. Upper container bottom. |
| 9. Adhesive tape. | 20. Bushing. |
| 10. Fuel container. | 21. Filling plug. |
| 11. Gasket. | |

FIGURE 4.—Details of the irritant candle.

indicates that ignition has taken place. In case of failure, push the wire back to its original position and again pull. Immediately after ignition, move at least 5 yards upwind of the candle.

(2) Do not attempt to ignite the irritant candle or to enter the cloud without adequate protection. Do not remove the adhesive tape covering the end of the pull wire or straighten or pull the wire loop until ready to use. The match head must be kept dry. Faulty or improperly functioning candles should be buried at a depth of 4 feet in the ground or placed 15 feet under water.

(3) Irritant candles are used only under the supervision of unit gas officers.

■ 70. SMOKE POT.—*a. Description.*—(1) The HC smoke pot consists of a cylindrical tin can filled with HC smoke mixture and equipped with a starter mixture, match head, and scratcher block. A metal handle is provided at the top to facilitate handling. The total weight of the smoke pot is 14.3 pounds, of which 12.5 pounds are smoke mixture.

(2) When the match head is ignited, flame comes in contact with the starter mixture and ignites it. This, in turn, ignites the HC smoke mixture and the evolution of HC smoke commences. The amount of smoke produced during the first 20 seconds is comparatively small. The average burning time is about 6½ minutes.

b. Operation.—Straighten the tab of the metal strap around the can, remove the tab from the slot, and remove the entire strap. Remove the other metal strap that passes over the handle. Remove the adhesive tape and metal cover. Draw the coated side of the scratcher block across the surface of the match head. The position of the smoke pot on the ground may be varied according to the rate of burning desired. If the smoke pot is set upon its base, the burning then will probably vary between the average and the maximum. Laying it on its side, on the other hand, tends to speed up the rate of burning.

SECTION IV

TACTICAL EMPLOYMENT

■ 71. GENERAL.—*a.* The tactical doctrine underlying the action of military force in civil disturbances is exploitation of the lack of cohesion which is characteristic of a mob to effect dispersion, thus relieving the menace of assembled opposition.

b. A chemical cloud, properly released, is a most effective means for advancing this end. Since the leadership of a mob is destroyed with the scattering of the crowd, no more than dispersion need ordinarily be attempted. For this reason casualty producing chemical compounds, appropriate to the degree of organized opposition encountered in warfare, are not needed against civilian disturbers of the peace.

■ 72. TECHNIQUE OF CLOUD TRAVEL.—Clouds generated by chemical munitions move in response to certain well-defined physical influences. An understanding of these is helpful in arriving at tactical decisions.

a. Since the clouds under consideration are created by heat processes, they are initially susceptible to convection.

b. If a smoke grenade is set off on a still, windless day, the emitted products of partial combustion will therefore ascend as does smoke from a cigarette in a draftless room. Combustion within the grenade being more rapid, however, all of its smoke cannot be accommodated in direct vertical ascent; some of it tends to spread horizontally until cooler air is found in which to continue its rise. Thus the cloud quickly assumes the shape of a cone. Besides its definite upward movement it also partakes of a lesser lateral movement or spread. But under such windless conditions, the cloud would soon pass into the upper atmosphere and be dissipated without producing any effect. Wind is therefore essential if the cloud is to be of practical value.

c. Wind counteracts convection and bends the ascending cloud toward the horizontal, imparting movement. The cloud, however, does not surrender its kinetic urge to rise; this persists so long as the mass retains heat and, if the wind force be moderate, accounts for a constant vertical widening of the

cloud. This may be increased further by the presence of natural convection currents in the area traversed.

d. Thus the wind imparts horizontal motion to the cloud while convection continues to produce a vertical spread equal to, roughly, a fifth of the distance traveled.

e. But wind force is never constant; it varies with altitude. Wind velocity 1 foot from the ground will average only half the velocity at 8 feet above the ground. This introduces a drag effect which imparts a rolling motion to the cloud.

f. Viewed in elevation, therefore, three distinct influences are to be observed in the advancing cloud: horizontal motion imparted by wind force; ascending motion resulting from heat; and centrifugal motion caused by varying wind velocities.

g. Viewed from above, still another characteristic of the wind-flattened cloud is to be noted—lateral spread. This is primarily a variation of the principle of convection; the cloud, always seeking cooler temperature and being somewhat restricted by air pressure from finding it aloft, tends also to move laterally. This effect is further accelerated by turbulence of wind force. The resulting horizontal movement is, like the vertical rise, equal to about one-fifth of the distance traveled.

h. This lateral spread is important, in that it accounts for the amalgamation of the independent clouds emitted from a series of grenades into a composite cloud at a distance which is proportional to the intervals between the several points of emission (fig. 5).

i. It is obvious that the several factors which have been noted in connection with cloud travel all combine to effect dilution, which of course influences the concentration at which the chemicals carried by the cloud reach the target. It must also be seen that so much of the cloud as passes the target at elevations greater than, say, 6 feet is wasted. At best, the absolute efficiency of the cloud is, therefore, low.

j. Chemically, the clouds generated from HC and DM are particulate in composition and may be classed as colloidal. CN is the only one of the agents under consideration that actually is dispersed as a gas. Dispersed DM is by common usage also termed "gas," although technically it is smoke.

k. Minute particles of DM, borne into the open atmosphere by heated vapors, quickly envelop themselves with minute films of heated air. These impart a buoyancy, due to convection, which more than counteracts the influence of gravity upon these tiny particles. They, therefore, continue to rise until the air immediately surrounding them has been cooled. Even then they continue to be carried along by wind force, and because of their infinitesimal weight tend to settle out very slowly. They are not susceptible to chemical dilution, as is CN; for this reason DM released from the irritant candle is credited with a range 10 times that of CN.

■ 73. GOVERNING TACTICAL FACTORS.—The tactics involved in the placement of gas clouds are governed primarily by wind, area occupied by the mob, and munitions available.

a. Wind.—The direction of the wind fixes the general vicinity of the line from which the cloud must be released in order to drift across the occupied area. The velocity of the wind influences the distance which should separate the line of release from the mob; strong winds indicate increased distance. This distance in turn affects the size of the cloud which must be released in order to immerse the mob with an effective (intolerable) concentration.

b. Area.—The area occupied by the mob determines the length of the line along which the cloud must be released. This line will usually be centered at right angles to the wind direction and should be sufficiently long to insure the creation of a cloud which, when it reaches the mob, will include considerably more than the area actually occupied. The length of the line corresponds, for practical purposes, to the average width of the cloud.

c. Munitions.—Chemical munitions should always be used in quantities ample to produce immediate and decisive effect (table III, par. 80). This principle must be kept constantly in mind. The scope of the action must be planned according to the ammunition available for (1) properly initiating the cloud, and (2) maintaining it until the mob has been dispersed. Selection of the type of munition is influenced by the nature of the opposition, considering that smoke causes no physiological effect, that tear gas causes intense temporary lacrimation, and that adamsite causes sustained physical distress.

■ 74. PRACTICAL APPLICATION.—*a.* It is important to emphasize that, while general procedures may be presented in print, experience is the only true guide to competence in the placement of chemical clouds.

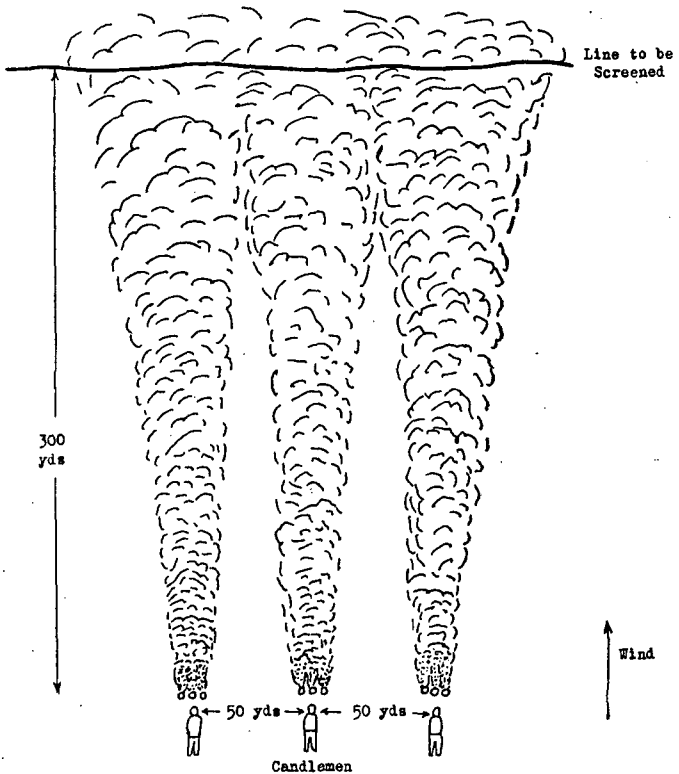

FIGURE 5.—Formation of clouds with 6 o'clock winds.

b. Although the quantity of grenades, candles, or smoke pots needed to cover a given area may be tentatively computed in advance, the manner of their employment must be determined on the spot. This is particularly so because chemical clouds are dependent for their movement on wind currents, which

in turn are notably variant over the type of terrain on which domestic disturbances are normally encountered.

c. The smoke grenade is valuable for gaging the direction and velocity of local wind and thus determining the size and placement of a cloud appropriate to the situation. Usually it is found desirable to set off a pilot grenade for this purpose. Within a few seconds the smoke emitted from this grenade will be sufficient to enable the experienced officer to visualize the general pattern of an appropriate chemical cloud and to determine the line from which it should be released.

d. At this point sound judgment must be exercised. The line of release should preferably be far enough to windward that the smoke from each separate grenade, candle, or smoke pot may have joined into one composite cloud before reaching the mob. Yet the distance must not be so great that this cloud may become unduly diluted before it passes over the mob. Judgment in this respect is best attained by repeated training exercises under a variety of wind and terrain conditions.

e. Having decided upon the line of release, a noncommissioned officer may be indicated to a position in the center of that line, facing the mob, with an equal number of grenadiers to his right and left. Grenades, candles, or smoke pots are then set off simultaneously and the cloud sustained or shifted as necessary until the mob has been forced to scatter.

f. The hand grenade should not be thrown into the mob; this relinquishes a primary tactical advantage afforded by chemicals—that of effectiveness from an appreciable distance upwind—and invites the initiative to the mob.

g. Along with the factors considered in the preceding subparagraphs, the responsible officer is also influenced in his decision as to the employment of chemical munitions by the general tactics of the situation with which he is confronted.

h. Since these munitions act powerfully to force dispersion, ample avenues for escape from the advancing cloud must be accessible. The direction in which the crowd will move must therefore be fully considered.

i. In cases where it is impossible to reach the windward side of mobs, rifle grenades must be resorted to; these may

be projected to windward, or, as a final resort, so as to fall directly into the crowd.

j. The situation may indicate desirability of preventing rioters from reaching a certain area. In such cases a blanketing cloud thrown about the area will serve to deter approach. Or a narrow cloud thrown across the center of a crowd will tend to split it to right and left; this recommends itself when no rearward path of retreat is to be had or when ammunition is limited.

k. In the special situation of desperados barricaded within a building, the building itself may be blanketed with a cloud, providing windows have previously been shattered so as to permit gas to enter. Rifle grenades also may be fired directly into the building, or smoke may be used to cover the approach of arresting parties.

l. Innumerable variations of the tactical use of chemical munitions will suggest themselves in proportion to the degree of thought devoted in advance to the application of principles to the various types of situations likely to be encountered. Officers are enjoined to visualize such situations in neighborhoods with which they are familiar and thus become prepared in advance to meet them.

SECTION V

PROTECTION

■ 75. **MILITARY PERSONNEL.**—*a.* Soldiers engaged in chemical operations are invariably masked. The mere wearing of masks insures an important psychological advantage which should not be overlooked. Masks not only protect grenadiers from irritant gases but also permit military police detachments to move with freedom through clouds and apprehend the most determined rioters.

b. Details of the service gas mask and instructions in its use are included in FM 21-40. The standard Army mask described therein may be depended upon adequately to protect the wearer against any of the chemicals used in civil disturbances. It is important to note, however, that the training mask is not suitable for such use.

■ 76. **RIOTERS.**—Types of protective devices with which rioters may be expected to equip themselves include handkerchiefs,

snug-fitting goggles, and gas masks. Handkerchiefs offer little protection but are often used instinctively by individuals fleeing out of a chemical cloud. Goggles may afford considerable protection against tear gas but none against other irritant gas. Commercial masks are expensive and are therefore seldom available in quantities; they also are not designed to protect against adamsite, which will penetrate any but the service type Army mask.

SECTION VI

PROBLEMS, EXAMPLES, RULES, AND TABLES

■ 77. ILLUSTRATIVE PROBLEMS.—The following examples merely show a proper use of chemical munitions in certain assumed situations. They should not be taken as a guide for the legal use of troops, as the question of the use of troops is a matter for determination in accordance with the laws governing the particular situation. (See AR 500-50.)

Problem 1: Riot in penal institution.

Situation.—(See ground plan, fig. 6.)

Colonel X, commanding a National Guard regiment in a large city, received a telephone call from the Governor of the State at 4:20 PM, May 12, saying that a riot had broken out in a nearby State penitentiary, and that Warden C requests aid and assistance be furnished at once. The Governor directed that the necessary assistance be rendered.

Colonel X sent Captain B and 10 soldiers in a truck with a supply of chemical munitions, consisting of 200 CN grenades and 100 HC grenades, to the prison to render assistance to Warden C.

Captain B arrived at the prison at 6:00 PM and found the situation as outlined below.

Prison A is a well-constructed fireproof prison built to accommodate from 800 to 1,000 inmates. It is somewhat overcrowded, now housing 1,500 prisoners. As the prisoners were assembled at 4:00 PM on the brick parade ground at the end of work on Monday, May 12, they suddenly attacked the guards and overpowered or killed all the interior guards except those in the warden's office and the hospital. All the guard pistols and the shotguns stored in the guard office were

seized. About 200 of the most desperate prisoners took charge, locking all the other prisoners in the cell block buildings but not in the cells. This mob of 200 has taken possession of the interior of the prison. The guards, about 25 in number, hold all guard towers, the warden's office, and the hospital.

The convicts have about 15 revolvers and some sawed-off shotguns with considerable ammunition in their possession. The cell blocks are in an uproar. The convicts in the yard are active in the vicinity of the printing shop.

Not more than 20 additional guards and policemen can be assembled within 3 hours to aid the prison authorities.

The prison guards are well supplied with gas masks, firearms, and ammunition, including machine guns mounted on principal towers.

At 6:00 PM, prisoners in the yard sent a message to the warden demanding that they be permitted to leave the prison or the whole prison population would be released. The warden demands that the prisoners surrender their arms and assemble in front of his office on the brick parade within 15 minutes. The prisoners promptly refuse.

At 6:30 PM, a shifting 4-mile breeze is blowing from the south. The sky is cloudy and threatening rain.

Warden *C* asks Captain *B* for his advice.

Required.—Captain *B*'s action.

A solution.—Captain *B* estimates the situation as follows:

The prisoners in the yard will release the prisoners in the cell block at dark and during the commotion will attempt to break out, through, or over, the wall near the railroad gate.

Captain *B* advises Warden *C* as follows:

First, use CN grenades upon the prisoners in the yard. Send 30 grenades to the hospital to be fired from the first floor north windows and order 12 grenades to be fired from each end of the warden's office simultaneously and a group of 12 grenades from the north windows of the warden's office. This group of grenades to be fired at 6:40 PM. At the same time warn the guards at gates 6, 7, and 8, to wear gas masks. At 6:45 PM, fire a second group of the same number of grenades in the same manner and from the same location as the first group. At 6:45 PM send a group of 10 guards

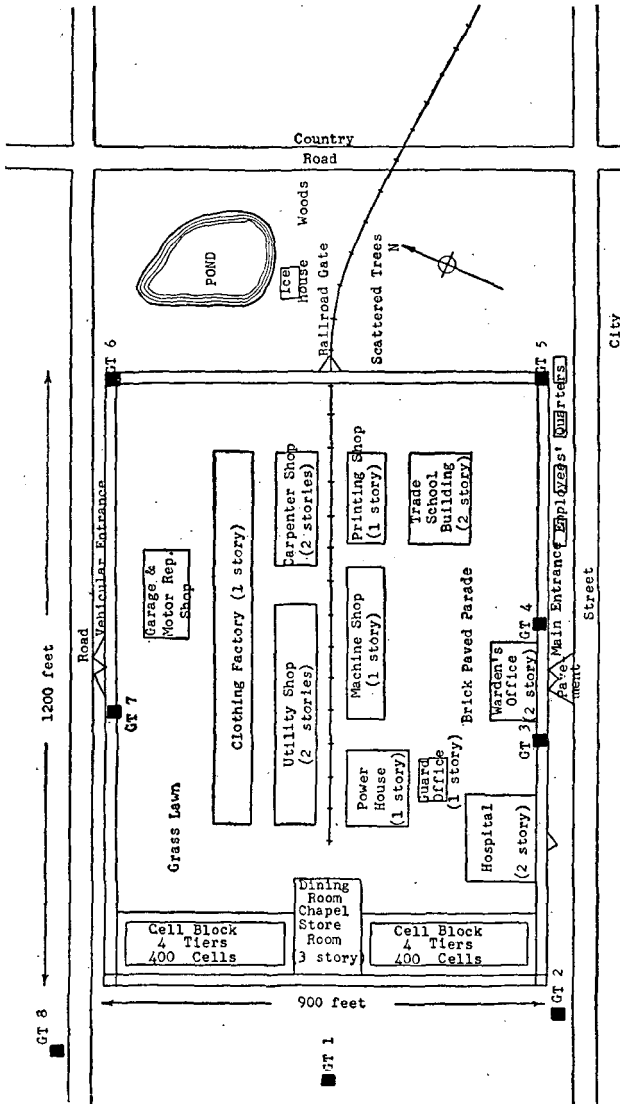

FIGURE 6.—Ground plan (problem 1).

equipped with gas masks and armed with submachine guns and light rifles to enter the railroad gate and call upon the prisoners to surrender.

Notes on the solution.—The time for action is very short. The mob being dealt with is desperate in character and must either be killed or completely incapacitated. They are well protected from rifle and machine-gun fire but have no gas protection. The wind is extremely favorable for effective use of the burning type chemical munitions. It is desirable to use a quick acting powerful agent. The concentrations of CN which can be quickly set up in all parts of the yard by the use of CN grenades are such that complete incapacitation of the inmates for a period of several minutes is to be expected. Captain *B*, therefore, chose to recommend the use of a CN smoke cloud of high concentration on those prisoners in the yard, knowing that the example so set would completely subdue the men in the cell houses. Had DM been available, Captain *B* would have chosen this munition instead of CN. The CN-DM grenade would have been a satisfactory munition for use in this situation. Smoke was not used in this situation as it might have afforded cover for the convicts to escape over the walls.

Problem 2: Mob determined upon lynching prisoner.

Location—On edge of small city.

Situation.—(See ground plan, fig. 7.)

Captain *B*, National Guard, has been called upon to furnish protection to a prisoner charged with a serious crime. Captain *B* has 50 men under his command and holds the jail area shown in figure 7.

He has established his company tents near the tool house of the jail, using the tool house as company headquarters and as a guard room. He is well supplied with rifles, bayonets, machine guns, gas masks, and chemical munitions.

A mob of men and boys, numbering about 200, has assembled on the edge of town on Highway No. 7 and about $\frac{1}{2}$ mile east of the Roaring River. It is reliably reported to Captain *B* that a determined effort will be made after dark to storm the jail and lynch the prisoner. Captain *B* writes a message to certain individuals reported to be the mob leaders, informing them that he and his men have been ordered by the Governor

of the State to protect the prisoner at all costs, and to see that the law of the land is upheld. He is firmly resolved to carry out his instructions. This letter he sends to the mob by two responsible local residents who can testify to its delivery. He then sends men in civilian clothing to mingle with the mob and learn its intentions.

At 7:00 PM, June 1, Captain *B* learns that the mob is on its way up the highway to attack the jail.

Required.—Captain *B*'s decision and actions.

A solution.—Captain *B* sends Lieutenant *Z* and two squads of men armed with tear gas rifle grenades to the bridge over the Roaring River on Highway No. 7. This detail moves up the road about 200 yards east of the bridge. Traffic is stopped on the highway at the filling station at 7th Street by a detail of three men. When the mob arrives at a distance of 300 yards from the bridge, Lieutenant *Z* will then fire volleys of tear gas grenades (16 at the time on a 100-yard front) upon them until they are dispersed.

Notes on the solution.—This situation is one distinctly unfavorable to the use of hand-thrown chemical munitions or to slow-acting chemical munitions of any kind. Rifle grenades filled with tear gas were chosen to break up the mob formation before it became necessary to fire upon them with machine guns and rifles. A few minor casualties by the falling rifle grenades are to be expected, but the casualties inflicted will be far less serious than those that would be inflicted by rifle fire.

Problem 3: Barricade in open country, with rioters provided with commercial gas mask protection.

Situation.—(See ground plan, fig. 8.)

A group of 250 rioters has taken possession of mine *Z* and has erected barricades which effectively cut off entrance to the mine. The rioters are armed with 50 sporting rifles and 200 shotguns and have advertised a determination to prevent the operation of the mine until their demands have been met. The rioters are known to be provided with good grade goggles and dust respirators of the snout type.

Major *X*, of the *n*th National Guard, has been ordered to disperse the rioters at this location. Major *X* has under his command two companies of Infantry: Company *A*, consisting

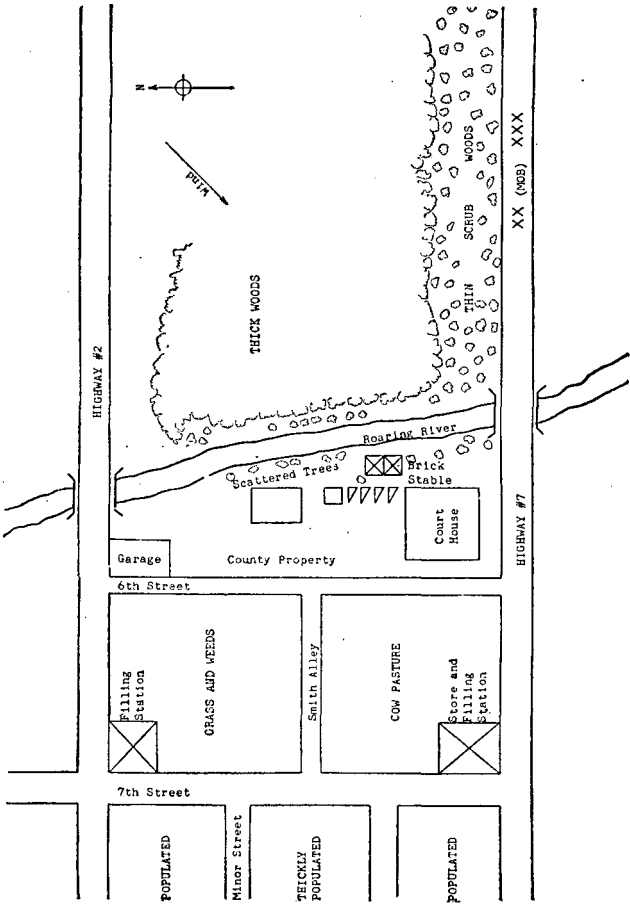

FIGURE 7.—Ground plan (problem 2).

of 75 men and 3 officers under Captain A; and Company B of the same strength under Captain B. Each company is divided into 2 platoons of 4 squads each and a headquarters section. Each company is supplied with rifles, bayonets, 4 automatic rifles, pistols, hand and rifle grenades, and DM candles. Fifty gas masks are in the battalion supply train.

Major X has made an airplane reconnaissance of the location and has plotted the position of the strikers' barricades upon accurate maps.

The battalion arrives by motor truck from the east and halts on the highway just north of Coal Hill at 3:30 PM. Major X joins the battalion just as it arrives, having come by fast motor car from the landing field after returning from the aerial reconnaissance.

Required.—Major X's procedure.

A Solution.—Major X forms his battalion on the road and marches south until he is under cover of the woods on the north slope of Coal Hill when he halts. He orders his men to lie down and calls a conference of his officers, first sergeants, and platoon sergeants. Here Major X outlines the situation and gives his orders.

Major X orders Captain A to form a battalion reserve at the place now occupied with his company less 1 officer (the Bn gas officer), 1 sergeant, and 2 squads. This group is ordered to take two DM smoke candles per man and get into position at the edge of the woods 200 yards northwest of Coal Hill along a 250-yard front on a northwest by southeast direction. Captain A also is to establish 2 patrols of 3 men and a noncommissioned officer each: one north of Coal Hill, and one on the south slope. Captain B is ordered to select 50 of his men, issue each man a gas mask and a CN-DM grenade, and take up a position in the edge of the woods on the southwest slope of Coal Hill. The remaining men of Company B are posted so as to provide small-arms fire to cover the subsequent operations of this company. All details to be in position by 4:00 PM.

At 4:00 PM, Lieutenant B, commanding the detachment from Company A, is to fire 16 DM candles on a 250-yard front so as to place the center of the cloud on the strikers barricaded just north of the mine entrance. At 4:10 PM,

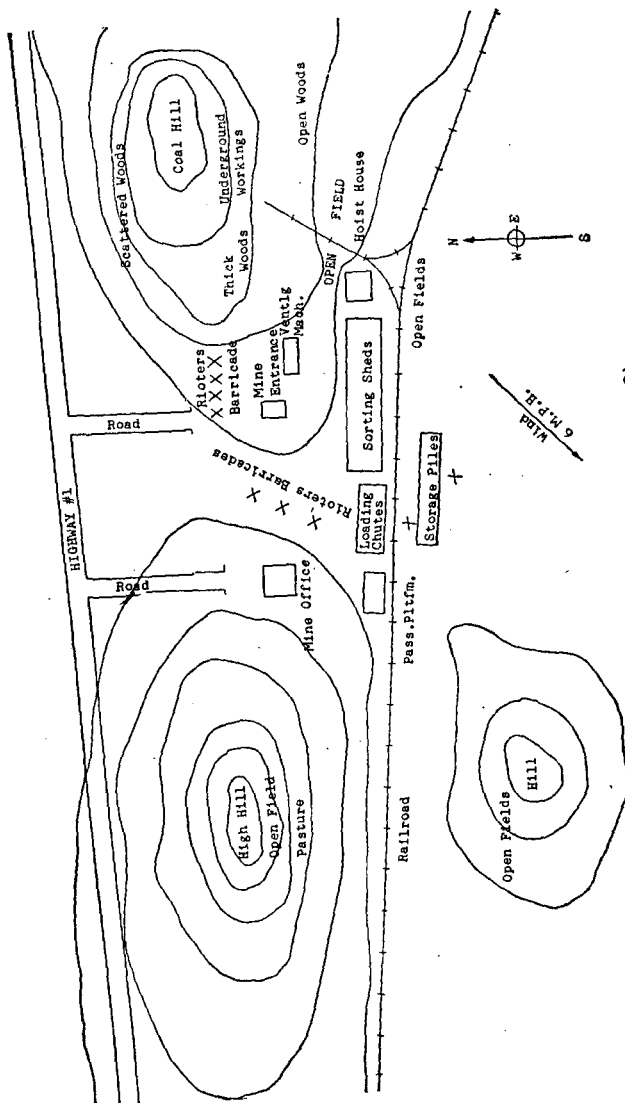

FIGURE 8.—Ground plan (problem 3).

he is to fire upon this position with his remaining 16 candles, placing candles on, and just upwind from, the barricade. Under cover of this irritant smoke cloud, Captain *B* is to move his company to the ventilating house and mine entrance. Captain *B* will use CN-DM irritant grenades on any barricaded groups remaining in the area.

Major *X* expects to force the surrender of the strikers in the barricade north of the mine entrance by these moves and further expects that the mob holding the remaining barricade will disperse.

Major *X* then moves his men to the mine office and establishes camp in the open field to the west of the office building. A squad under command of a sergeant and armed with 8 rifles and 1 automatic rifle is placed in each of two trucks to patrol the highway. A locomotive and steel coal car manned by a squad and an officer are fitted for patrol on the railroad. Four patrols of three men and a non-commissioned officer each are detailed for guard duty in the mine area proper. Arrangements are made to secure first-aid treatment for the prisoners and to turn them over to higher military authorities.

Notes on the solution.—As the rioters are provided with goggles and miners' masks, tear gas (CN) would not be effective, hence Major *X* must use more powerful chemical weapons. The DM candle is chosen for a surprise attack on the whole force of rioters. Under the conditions of wind and terrain the whole barricade should be covered by a high and incapacitating concentration of DM smoke, and the first barricade just north of the mine entrance would be exposed to a particularly heavy concentration. Two separate clouds are released as this will produce the double effect only on the most stubborn members of the mob. By the use of this munition, he penetrates their protection and destroys their fighting resistance without causing any permanent incapacitating action. Also, since DM smoke is nonpersistent, the unmasked soldiers can follow up the cloud and will not be incapacitated unless they enter the cloud. As a precaution, however, masks were worn by Company *B* which entered the area.

The successive action was merely to take advantage of the initial results obtained and to clear the area of the mob.

This example again illustrates the value of chemical agents in getting immediate incapacitating results by the use of a relatively small quantity of munitions in a surprise attack.

Problem 4: Barricaded criminals in center of population.

Situation.—(See ground plan, fig. 9.)

Three criminals have barricaded themselves in a small apartment house in a thickly populated area. The houses are two-story apartments with a separate entrance front and back into each apartment. There is no connection between apartments. The walls separating the apartments are made of hollow tile, one tile thick.

All three of the criminals are wanted for serious crimes, and it is believed that they will die fighting rather than surrender. They are well supplied with revolvers and ammunition and have defied the police to come and get them. They have no gas protection. The police are commanded by Police Sergeant C who has 10 patrolmen on the scene armed with revolvers and four shotguns. The police are supplied with CN-DM grenades and suitable gas masks.

Required.—Sergeant C's decision and action.

A solution.—Sergeant C stops traffic on 2d Avenue between 21st and 22d Streets, placing an officer at each corner to warn people away. The inhabitants of the neighborhood are warned to keep indoors with all windows and doors closed. Sergeant C then places himself and the rest of his men behind such individual shelter as can be found in both front and rear of the apartment in which the criminals have taken refuge so as to cover all doors and windows. Several windows on each floor are then smashed by shotgun fire, after which two CN-DM grenades are projected into each room. All windows are covered by shotgun fire while the grenades are being thrown into the building. After 5 minutes, additional CN-DM grenades will be tossed into the apartment if the men have not come out. The high concentration of gas now in the building will be incapacitating. If they do not come out in 5 minutes, Sergeant C and his men enter the building and capture the criminals.

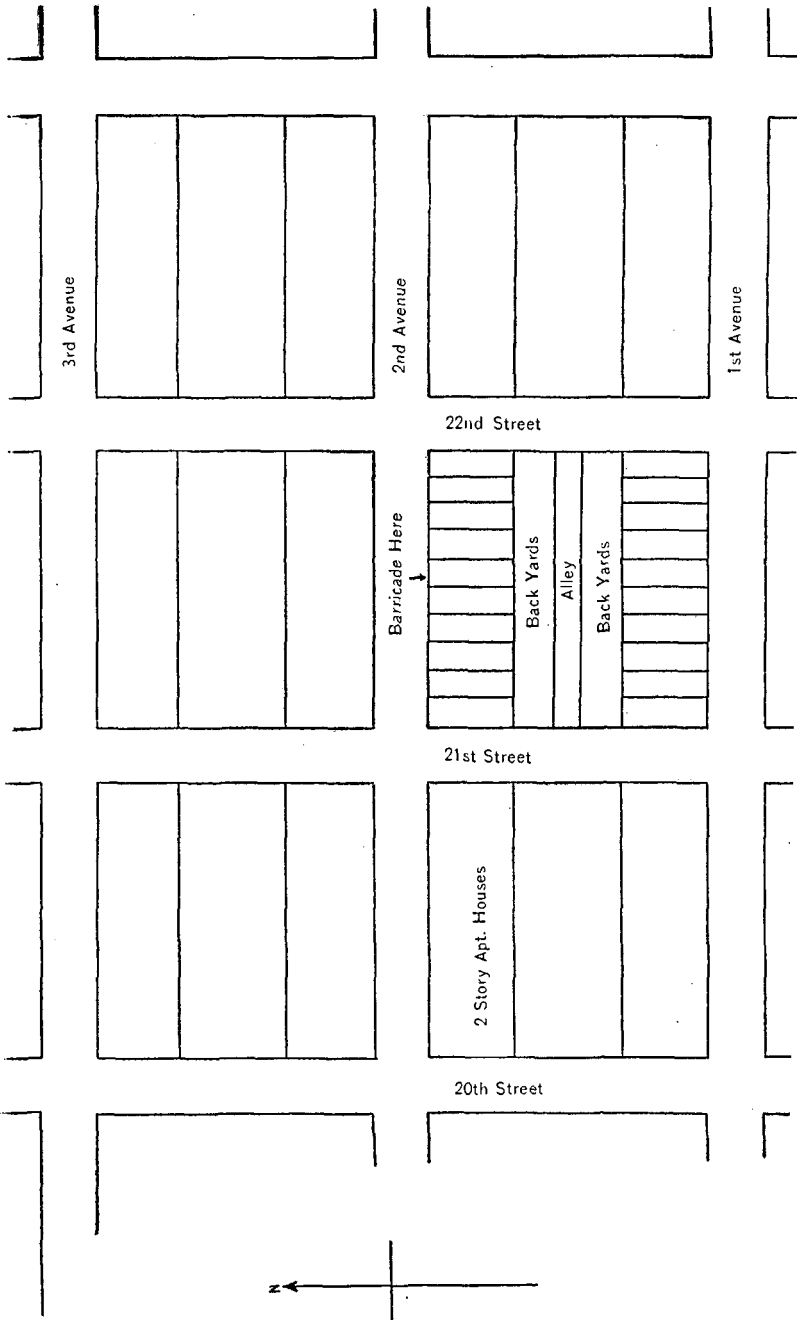

FIGURE 9.—Ground plan (problem 4).

Notes on the solution.—CN-DM grenades are used in this case since it will accomplish the object desired without danger to the community. In the enclosed space occupied by these criminals, the DM from these grenades should be very effective.

Problem 5: Disorderly street gathering.

General situation.—A group of rioters has created much disturbance in Petn, a mill town of about 10,000 population. Several grocery stores, one department store, and a bank have been broken into and looted. The local police have killed two members of the mob and wounded several others. The rioters in turn have fired on the police, thrown rocks at the police station, and have threatened to kill any policemen found on the street. The mob has been in control of the town for a day and a night.

Special situation A.—You are Captain *B* in command of Company *M* of the *x*th National Guard, located in a town 50 miles away. At 3:00 PM, September 6, you receive orders from your adjutant general as follows:

Proceed to Petn, protect property, arrest the ringleaders, restore order, and await further instructions.

At 4:00 PM, same date, you send forward Lieutenant *X* and Sergeant *Y* in civilian clothes by private automobile to observe the situation in Petn and report to you at a convenient place on the route.

At 6:00 PM, you assemble 50 men of your organization and proceed by motor transportation toward Petn.

Your arms and supplies are as follows: 12 automatic pistols, 32 rifles, 6 automatic rifles, ample ball ammunition, 10 gas masks, 50 grenades, hand, tear, CN, M7, 50 grenades, hand, smoke, HC, M8.

At 8:30 PM, Lieutenant *X* meets you at a point 5 miles from town and presents the following report:

Approximately 500 rioters are in the town. About 200 are in small groups of 5 and 6 to the group and one large mob of 300 has assembled in the business district on the main street. There is little effective leadership or control of the mob. It is believed they intend to break into several large jewelry and department stores later in the night. Main Street runs north and south. A gentle north wind is blowing. The City Hall is on Main Street several blocks north of the business district.

The city waterworks and gas plant are located about $\frac{1}{2}$ mile north of town and 1 mile from the business district. Sergeant Y will meet the captain at the city hall with the latest information.

See sketch map of area (fig. 10) and plan of downtown Petn (fig. 11).

Required.—Your plans for approaching the town, including route of approach, distribution of supplies, and plan for entering the town.

A solution.—*a.* Captain A passes to the north of town and approaches from that direction as soon as possible.

b. At the waterworks he halts his company, explains the situation as he knows it, and gives his instructions, viz:

(1) Lieutenant X is detailed to command 9 men, fit them with gas masks, arm the group with 8 automatic pistols and 2 automatic rifles, take the smoke and tear gas grenades, and place this group in 2 light motor cars.

(2) The automatic rifles are distributed along with the remaining men to the other vehicles so that one automatic rifle is in each vehicle.

c. (1) Captain B then forms his company and proceeds to the open field just north and east of 1st Avenue and Main Street, where he parks his transportation and leaves 2 automatic riflemen and 2 riflemen on guard.

(2) Lieutenant X is ordered to move his detail to City Hall, confer with Sergeant Y, then attack and disperse the mob with tear gas and smoke grenades.

(3) Captain B divides the remainder of his company into two detachments. He conducts one of these south along 1st Street, E., and Lieutenant Z conducts the other south on 1st Street, W. Both detachments are to regulate their advance on the movements of Lieutenant X. Captain B and Lieutenant Z with their detachments will arrest such rioters as come their way. Both detachments must stay upwind from the tear gas cloud set up by Lieutenant X. All detachments are ordered to refrain from the use of firearms except in actual defense of life.

Special situation B.—You are Lieutenant X. Upon arrival at the City Hall, Sergeant Y delivers the following report:

About 200 rioters are now breaking into a large department store 4 blocks south on Main Street.

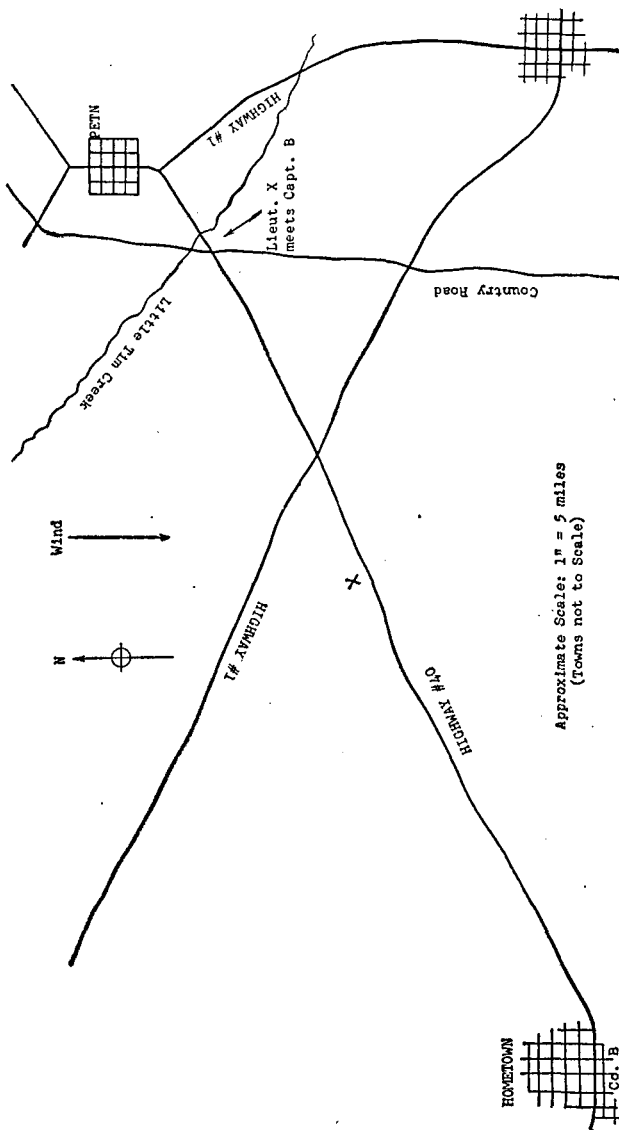

FIGURE 10.—Sketch map (problem 5).

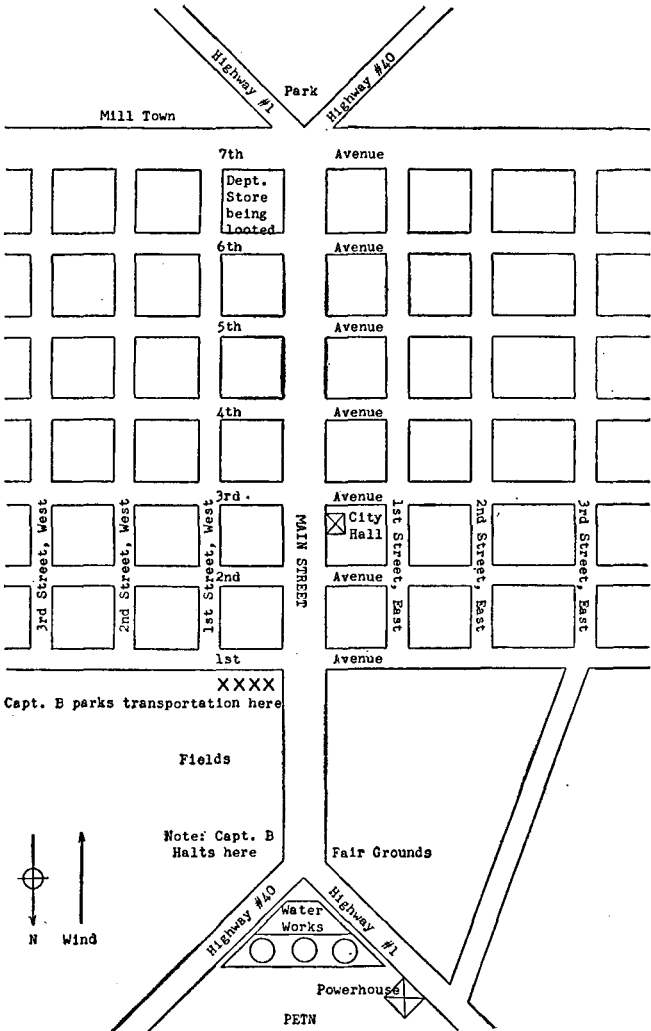

FIGURE 11.—Ground plan (problem 5).

Required.—Your action.

A solution.—Lieutenant X directs his 2 automatic riflemen to proceed down the street ahead of his group, 1 on each side of the street to protect the other 8 men. Each of these men takes 5 CN grenades and 5 HC grenades. Four men are placed on each side of the street, preceded by the automatic riflemen. The group moves two blocks south, then fires 2 CN candles per man (16 in all). All men will then adjust gas masks, wait 2 minutes, and proceed toward the business district. Under cover of the tear gas screen, Lieutenant X will then advance his men to the department store and fire CN and HC grenades into this building and capture such of the looters as stagger out through the smoke and gas cloud.

Sergeant Y acts as a rear guard for this detachment.

Notes on the solution.—This problem indicates the general method of approach to a dangerous mob situation as well as the manner of breaking up a mob already formed. Note the tremendous fire power of this organization which is kept in reserve. The knowledge of this fire power will place confidence in the soldiers. The relatively harmless tear gas and smoke will provide the necessary impulse to put this mob to rout. Ample routes of escape to both flanks are left open. The flank detachments can capture as many prisoners as may be deemed necessary. If in this situation smoke pots had been available instead of smoke grenades, they could have been used in a manner similar to that indicated for the grenades. It must be remembered in this connection that smoke pots may not be thrown and that their time of burning is considerably more than that of grenades.

■ 78. EXAMPLES ILLUSTRATING USE OF CHEMICALS.—The following examples show a few cases where chemicals have actually been used in mob control and for the capture of criminals. Names and locations, of course, have been altered from the original reports but otherwise these examples are taken from the original reports of the officers present as eye-witnesses at these disturbances.

Example 1.—A commercial grenade, similar to the Government grenade, hand, irritant, CN-DM, M6, was used on a group of rioters in a mine area. The report makes the following statement:

We obtained the best results with this type of candle with the 2-second fuse. No one was able to pick it up and throw it back at the troops as it usually ignited before hitting the ground, and the high-speed mixture caused intense heat and prevented anyone from picking it up. The effect on the mobs the first time we used it was that they merely thought it was CN that had been used on them before, and did not cause them to disperse, but after several minutes when some of them became sick they dispersed promptly. The effect on the persons gassed was that they became nauseated and very sick, but we never had any serious results, nor did we have to use this gas in that neighborhood again. The mere mention of gas was sufficient to disperse them after the first time. The only precaution that we had to observe was that it generates extreme heat and may cause fire. We used the candles with a fin attached and dropped them from an airplane with good results. A contact fuse was used on this candle.

Example 2.—The following report was made on the use of nonlethal chemical agents in subduing a riot within a penitentiary:

A mixture of CN and DM gas was supplied to the State police who were patrolling the prison at that time. The gas was used in the form of billy shells and hand grenades. Six of the former and one of the latter were released in a cell room 80 by 8 by 10 feet, in which approximately 100 prisoners were locked in 10 cells. Approximately 39 grams of the chemical agent were released in this space.

These prisoners had been staging riots for 3 days. They had ripped all furnishings loose in their cells and caused a great deal of damage to property. Two guards equipped with gas masks kept constant watch over the men while they were under the effects of the gas. Two doctors were in attendance also. Inasmuch as circulation of air in the room was very poor and cells crowded, some prisoners were not exposed to as heavy a concentration as others. The concentration of DM as a whole would not be considered a heavy concentration.

All rioting ceased when the gas was used and has not been resumed since. Had the same treatment been applied 3 days earlier, it would have prevented considerable property destruction and adverse criticism of the prison administration. Unfortunately, however, the prison was not equipped with gas at that time and the guards were not trained in its use, so gas was not resorted to until every other method had failed. A heavier concentration would undoubtedly have resulted in severe and longer lasting results, but judging from the results obtained this was not necessary in this case.

Concerning the physiological effects noted, the following extracts of comments by a doctor in this case are reproduced herewith:

The first objective symptom was sneezing and coughing. This came on approximately $\frac{1}{2}$ to 1 minute after the gas was released. Both the coughing and sneezing became more frequent, reaching their height in about $2\frac{1}{2}$ to 3 minutes. Retching and vomiting first appeared about $2\frac{1}{2}$ minutes after release of the gas, increased in frequency up to the time the men were let out in the open air—4 minutes after releasing the gas.

When the men were led out of the building approximately one-third were retching and occasionally vomiting; approximately one-third were occasionally sneezing and coughing frequently, while the remaining ones apparently walked out unaffected or very slightly so. Approximately one-fifth to one-sixth of the men staggered out as if intoxicated. These men were for the most part nauseated and were vomiting.

The following are the physical findings on the inmates of this prison following the use of gas in this case:

(1) All showed a congestion of the conjunctiva with excessive lacrimation.

(2) Approximately one-half showed a congestion of the lining of the nose.

(3) Approximately one-fourth showed from a slight to a moderate redness of the pharyngeal wall.

(4) None showed any skin lesions.

(5) I examined approximately 20 men's hearts. All of these showed slow, almost deliberate, heart beats without any irregularity of the rhythm, rate, or the strength of the beat. Blood pressures were not taken. The pulse in all these and many more that I felt was slow, regular in rhythm and force, and good in volume.

(6) I examined the lungs of those who complained of a feeling of suffocation, those who were prostrate, and approximately a dozen others.

(7) Temperatures were taken of those who were most affected. No elevations were found. This was repeated 2 hours later and findings were similar.

Conclusions.

It is my belief that not all of the men received equal doses of DM vapor, that some showed very slight effects. There is a possibility that the individual susceptibility is variable. The effect of DM could be said to be twofold:

(1) An irritation of the lining of the entire respiratory tract;

(2) A stimulating action on the smooth muscle of the gastrointestinal tract.

My opinion is that the action is through the central nervous system, very likely through the vagus nerve, as the slowing of the heart rate was a fairly constant sign. The effect is a very temporary one, as in practically all these men the symptoms subsided in 2 hours. In many there was a fair degree of comfort in less than 1 hour. An occasional headache was complained of the following morning. In none of this group was it found necessary to stimulate anyone or to treat the respiratory symptoms.

Example 3.—The following summary is made of the experience of one officer in a number of riots in and around a large industrial center. The statement along this line is as follows:

The lessons I have learned from riot duty observations are—

(1) Protection of the candeliers must be definite and apparent.

(2) The candle squad must use gas masks.

(3) The candle squad must be skilled in the prompt use of their munitions. In a 30-mile gale, throwing grenades or quick-burning candles into the mob would probably affect more people in its swirling cloud and interfere with the return of the mob to its original objective.

(4) Riflemen protecting candle squads may have to use fire power to protect the candeliers.

Example 4.—The following example has been reported by a National Guard officer of very considerable experience in this type of duty:

Major X, commanding the mine area, called for a chemical unit to disperse rioters in field north of mine property $\frac{1}{2}$ mile and to the west of mine road. The sheriff issued a proclamation that no strikers should congregate within 2 miles of mine property. Major X wants this mission accomplished before 5:30—at which time the working miners would be brought past the field, thence to their homes.

Captain B has charge of chemical unit and reports to Major X at 4:30.

Captain B's action.—Six men of the chemical unit, supported by one squad of Infantry, move to bridge over Clear Creek. Upon arrival, they discover that rioters have guns and are determined to resist any opposition to their remaining there.

A lateral wind is blowing about 3 m. p. h.

Captain B sends 3 men north on creek under cover of trees to a place opposite the rioters and upwind of them. They are to fire at 5 o'clock 3 HC candles.

This order was carried out after due warning to disperse. When the smoke has entirely covered the mob, Captain *B*, with his men, advanced without trouble and three CN-DM candles were released in the smoke cloud.

Four minutes later the rioters had all left the field. We gave them an exit out the gate of the field to mine road, thence to highway. One squad and one officer of Infantry were stationed at junction of mine road and main highway to search all rioters for guns. This was an easy job due to their extremely nauseated condition. Guns were confiscated, leaders arrested for inciting a riot and turned over to the civil authorities.

This is an example in which, without the use of gas, there would have been killing and serious wounding of men on both sides. From its outcome alone this justifies all the time spent in the training of personnel and cost of matériel.

Example 5.—The following extracts of a report covering the use of chemical agents in a strike during 1933 are of interest:

During an attempt to disperse a mob of about 200 men, they fled to a house about 100 yards southwest of the crossroads and entered same. They were throwing rocks at approaching guardsmen. Also the owner of the house was making threats to fire upon guardsmen for trespassing. Two men having masks slipped up to the front door, facing east, and tossed in two grenades. The house was about 20 by 20 feet, two stories, but the action of these grenades was sufficient to clear same easily. Material was what is known as knock-out grenades (same as CN-DM grenade). I do not know the actual composition of same but from its action believe it is a combination of a lachrymator and sternutator. It was something new to us, but would recommend its use in civil disturbances as highly effective. Again the terrain and wind element did not enter into the use of chemicals, either for or against. Upon coming out of the house, the pickets retreated west to rear of the house. More CN candles were set off and also knock-out grenades thrown among them, causing them to retreat still further south and west, which was what we desired.

An amusing incident which demonstrated how much afraid a mob is of gas occurred when one man was detailed to go around some buildings and get on the flank to windward of a group of about 50, while other guardsmen approached them from the front. The one man got far ahead of his comrades with the result that he burst out on flank and partly in front of the mob before his comrades got within effective range. Instead of retreating or trying to hold his ground, he coolly discharged a knock-out grenade and rolled it along the road into their midst. At the same time he ran directly toward

them holding another in readiness for firing. At the approach of the rolling grenade, the mob, outnumbering him 50 to 1, turned and fled. He rolled the second grenade toward them, adding to their confusion, and totally dispersed them single-handed.

In conclusion, wish to state that all efforts should be made when the use of gas is contemplated to supply plenty of it. It certainly has a far greater effect on civil disturbance mobs than physical force, display of weapons, or show of force. A man, in the position of the pickets and strikers we encountered, is intelligent enough to know that you are not actually going to assault and kill or injure him. Neither will you risk the destroying of your prestige by engaging him in personal combat either as a group or individually for the purpose of removing him from disputed territory, but when you use gas, making no actual show of firearms, from a safe distance from the mob, you bring them into contact with something they cannot combat, and have no choice except the one you give them—to remove themselves from the region. This effect can be easily destroyed by not having enough gas to make it effective.

■ 79. GENERAL RULES ON EMPLOYMENT OF CHEMICAL MUNITIONS.—The following rules emphasize important points pertaining to the employment of chemical munitions which should be borne in mind when preparing for or participating in chemical disturbances:

a. Chemical squads or detachments so detailed for this duty should be carefully selected and trained prior to arrival at the scene of disturbance.

b. Try to make as complete an estimate of the mob as time will permit with respect to intentions, temper, size, grievances, available protective devices, and so forth.

c. Be prepared to act promptly.

d. Do not hesitate to use plenty of gas.

e. Inconspicuous locations should be selected for release of gas, and detachments charged with this duty should be supported by designated riflemen.

f. Maneuver so as to approach a mob from the windward, thus enabling the cloud to travel to the mob while the troops remain beyond missile usage.

g. The plan of action should provide definite avenues for escape; the tactical ideal is to permit the mob to flee in several directions before an advancing gas cloud.

h. When smoke is used, care must be exercised that it does not benefit rioters by screening their movements to points of vantage.

i. In case of a shortage of chemical ammunition, use an effective concentration of gas on a small part of the mob holding the key position.

j. Military personnel should be provided with masks. If the number of masks is limited, they should be issued to the chemical squad, the protecting riflemen, and any individuals who might be required to mingle in the mob to make arrests.

TABLE I.—*Characteristics of chemical agents for use in civil disturbances*

Common name.....	Tear gas		Adamsite		Smoke
	CN	CN-DM	DM	HC	
CWS symbol.....					
Composition.....	Chloracetophenone smokeless powder; magnesium oxide.	Chloracetophenone; diphenylaminechlorarsine; smokeless powder.	Diphenylaminechlorarsine; smokeless powder; magnesium oxide.	Hexachlorethane; zinc powder; zinc oxide.	
Odor.....	Like locust blossoms.....	No characteristic odor; irritating.	Like camphor.	
Persistence (in open).	Variable according to wind conditions; maximum 10 minutes.	
Minimum effective protection.	Tight fitting goggles.....	Best commercial mask.....	Best Army mask.....	None needed.	
Physiological action.	Lacrimation; mild skin itching.	Sneezing, lacrimation, vomiting.	Sneezing, violent headache, vomiting.	None.	
First-aid treatment.	Wash eyes with boric acid solution; keep eyes open and face into wind of un-contaminated air.	Wash eyes with boric acid; breathe chlorine in low concentration.	Breathe chlorine in low concentration.	None needed.	
Munitions in which filled.	Grenades, hand and rifle.....	Grenades, hand.....	Candles.....	Grenades, hand.	

TABLE II.—Statistics, chemical grenades, candles, and smoke pots

Technical name.....	Grenade, hand, smoke, HC, M8	Grenade, hand, tear, CN, M7	Grenade, hand, irritant, CN-DM, M6
Filling.....	HC burning mixture.....	CN burning mixture.....	CN-DM burning mixture.....
Weight of effective filling.....	29 ounces.....	4 ounces.....	5 ounces.....
Weight of complete munition.....	32 ounces.....	16 ounces.....	20 ounces.....
Time of functioning.....	3 minutes.....	1 minute.....	1 minute.....
Persistence in open.....	Variable according to wind conditions; maximum 10 minutes.....	Variable according to wind conditions; maximum 10 minutes.....	Variable according to wind conditions; maximum 10 minutes.....
Persistence in halls.....	30 minutes.....	1 hour.....	1 hour.....
Persistence in closed rooms.....	do.....	6 hours.....	6 hours.....
Effective range of cloud from 1 munition (favorable conditions).....	100 yards.....	200 yards.....	75 yards.....
Technical name.....	Grenade, rifle, tear, CN, Mk.2	Candle, irritant, DM, M1	Pot, smoke, HC
Filling.....	CN burning mixture.....	DM and smokeless powder.....	HC burning mixture.....
Weight of effective filling.....	2 ounces.....	32 ounces.....	12.5 pounds.....
Weight of complete munition.....	23 ounces.....	9¼ pounds.....	14.3 pounds.....
Time of functioning.....	30 seconds.....	2 minutes.....	6½ minutes.....
Persistence in open.....	Variable according to wind conditions; maximum 10 minutes.....	Variable according to wind conditions; maximum 10 minutes.....	Variable according to wind conditions; maximum 10 minutes.....
Persistence in halls.....	30 minutes.....	30 minutes.....	30 minutes.....
Persistence in closed rooms.....	3 hours.....	Until cleaned up.....	30 minutes.....
Effective range of cloud from 1 munition (favorable conditions).....	50 yards.....	500 yards.....	500 yards.....

NOTE.—*Special Precaution:* These grenades, candles, and smoke pots are burning type munitions. If any of them are ignited in close proximity to easily combustible material, fires are liable to result.

TABLE III.—Minimum ammunition requirements for smoke and gas clouds¹

Width of initial cloud front (all munitions evenly distributed and fired simultaneously on the front)	[Wind perpendicular to firing front]					
	250 yards down wind		500 yards down wind		1,000 yards down wind	
	Number of munitions required ²	Width of cloud Yards	Length of time effect lasts at target ³ Minutes	Number of munitions required ²	Width of cloud Yards	Length of time effect lasts at target ³ Minutes
Point.....	<i>Hand grenades</i> ⁴ 4	50	2	<i>Hand grenades</i> ⁴ 25	100	3
25 yards.....	6	75	2	25	125	3
100 yards.....	20	150	2	50	200	3
250 yards.....	40	300	2	80	350	3
Point.....	<i>Irritant candles</i> 1	50	3	<i>Irritant candles</i> 5	100	3
25 yards.....	3	75	3	8	125	3
100 yards.....	6	150	3	15	200	3
250 yards.....	12	300	3	30	350	3
Point.....	<i>Pot., smoke, HC</i> 1	50	6	<i>Pot., smoke, HC</i> 1	100	6
25 yards.....	2	75	6	2	125	6
				<i>Hand grenades</i> ⁴	<i>Yards</i>	<i>Minutes</i>
				50	225	4
				75	300	4
				120	450	4
				<i>Irritant candles</i>		
				20	225	4
				35	300	4
				50	450	4
				<i>Pot., smoke, HC</i>		
				7	225	8

100 yards.....	5	150	6	5	200	6	10	300	8
250 yards.....	12	300	6	12	350	6	18	450	8

¹ These data are generally acceptable under favorable meteorological conditions; fair days and moderate (6 to 8 m. p. h.), steady winds. Excessively high winds preclude use of clouds, as do low and intermittent winds.

² These numbers may be advantageously increased when available ammunition permits.

³ See table II for time of functioning of various munitions. Maintenance of cloud until dispersion is effected should be attempted, but short, heavy concentrations are preferable to sustained light concentrations.

⁴ Data under hand grenades assume combined use of smoke and irritant grenades; for smoke alone, reduce these estimates; for irritants alone, increase them.

APPENDIX

STATUTORY LIMITATIONS AND AUTHORIZATIONS

■ 1. USE OF ARMY AS POSSE COMITATUS.—From and after the passage of this act it shall not be lawful to employ any part of the Army of the United States, as a posse comitatus, or otherwise, for the purpose of executing the laws, except in such cases and under such circumstances as such employment of said force may be expressly authorized by the Constitution or by act of Congress; * * * and any person wilfully violating the provisions of this section shall be deemed guilty of a misdemeanor and on conviction thereof shall be punished by fine not exceeding ten thousand dollars or imprisonment not exceeding two years or by both such fine and imprisonment. *Sec. 15, act of June 18, 1878 (20 Stat. 152; 10 U. S. C. 15; M. L., 1939, sec. 480).*

■ 2. AUTHORITY TO CALL FORTH MILITIA.—Whenever the United States is invaded or in danger of invasion from any foreign nation, or of rebellion against the authority of the Government of the United States, or the President is unable with the regular forces at his command to execute the laws of the Union, it shall be lawful for the President to call forth such number of the militia of the State or of the States or Territories or of the District of Columbia as he may deem necessary to repel such invasion, suppress such rebellion, or to enable him to execute such laws, and to issue his orders for that purpose, through the governor of the respective State or Territory, or through the commanding general of the Militia of the District of Columbia, from which State, Territory, or District such troops may be called, to such officers of the militia as he may think proper. *Sec. 4, act of Jan. 21, 1903 (32 Stat. 776), as amended by sec. 3, act of May 27, 1908 (35 Stat. 400); 32 U. S. C. 81a; M. L., 1939, sec. 1295).*

■ 3. FEDERAL AID FOR STATE GOVERNMENTS.—In case of an insurrection in any State against the government thereof, it shall be lawful for the President, on application of the legis-

lature of such State, or of the executive, when the legislature cannot be convened, to call forth such number of the militia of any other State or States, which may be applied for, as he deems sufficient to suppress such insurrection; or, on like application, to employ, for the same purposes, such part of the land or naval forces of the United States as he deems necessary. *R. S. 5297 (50 U. S. C. 201; M. L., 1939, sec. 502).*

■ 4. USE OF MILITARY AND NAVAL FORCES TO ENFORCE AUTHORITY OF FEDERAL GOVERNMENT.—Whenever, by reason of unlawful obstructions, combinations, or assemblages of persons, or rebellion against the authority of the Government of the United States, it shall become impracticable, in the judgment of the President, to enforce, by the ordinary course of judicial proceedings, the laws of the United States within any State or Territory, it shall be lawful for the President to call forth the militia of any or all the States, and to employ such parts of the land and naval forces of the United States as he may deem necessary to enforce the faithful execution of the laws of the United States, or to suppress such rebellion, in whatever State or Territory thereof the laws of the United States may be forcibly opposed, or the execution thereof forcibly obstructed. *R. S. 5298 (50 U. S. C. 202; M. L., 1939, sec. 503).*

■ 5. DENIAL BY STATE OF EQUAL PROTECTION OF LAWS.—Whenever insurrection, domestic violence, unlawful combinations, or conspiracies in any State so obstructs or hinders the execution of the laws thereof, and of the United States, as to deprive any portion or class of the people of such State of any of the rights, privileges, or immunities, or protection, named in the Constitution and secured by the laws for the protection of such rights, privileges, or immunities, and the constituted authorities of such State are unable to protect, or, from any cause, fail in or refuse protection of the people in such rights, such facts shall be deemed a denial by such State of the equal protection of the laws to which they are entitled under the Constitution of the United States; and in all such cases, or whenever any such insurrection, violence, unlawful combination, or conspiracy, opposes or obstructs the laws of the United States, or the due execution thereof, or impedes or obstructs the due course of justice under the same, it shall be lawful for

the President, and it shall be his duty, to take such measures, by the employment of the militia or the land and naval forces of the United States, or of either, or by other means, as he may deem necessary, for the suppression of such insurrection, domestic violence, or combinations. *R. S. 5299 (50 U. S. C. 203; M. L., 1939, sec. 504).*

■ 6. PHILIPPINE ISLANDS.—(12) The Philippine Islands recognizes the right of the United States * * * to maintain military and other reservations and armed forces in the Philippines, and, upon order of the President, to call unto the service of such armed forces all military forces organized by the Philippine government.

* * * * *

(14) The United States may, by Presidential proclamation, exercise the right to intervene for the preservation of the government of the Commonwealth of the Philippine Islands and for the maintenance of the government as provided in the constitution thereof, and for the protection of life, property, and individual liberty and for the discharge of government obligations under and in accordance with the provisions of the constitution. * * * *Extract from section 2, Philippine Independence Act, and from section 1, Ordinance appended to the Constitution of the Commonwealth of the Philippine Islands (48 Stat. 456; 48 U. S. C, 1232),*

INDEX

	Paragraphs	Pages
Airplanes:		
Discovery of fires and observation of rioters.....	54	29
Limitations on use.....	9	7
Ammunition.....	24	15
Armored units.....	22	13
Artillery, use in riot duty.....	22	13
Aviation, use in riot duty.....	9, 22, 54	7, 13, 29
Barricaded criminals in a center of population, illustrative problem.....	77	48
Barricade in open country, rioters provided with commercial gas masks, illustrative problem....	77	48
Barricades:		
Attacking.....	37	21
Construction by troops.....	37	21
Buildings occupied by rioters, attack against....	36	20
Candles, irritant, description, and use.....	65, 69	34, 39
Cavalry, use in riot duty.....	22, 40	13, 22
Chemical agents:		
Advantages.....	62	33
Defined.....	61	32
Examples illustrating use.....	77, 78	48, 63
Factors governing use.....	74	45
Grenades, candles, and smoke pots, statistics..	80	70
Incendiary action.....	63	33
Obscuring smoke.....	63	33
Pots, smoke.....	70, 74	41, 45
Physiological effects.....	63	33
Protection:		
Military personnel.....	75	47
Rioters.....	76	47
Relative effectiveness.....	64	33
Table of characteristics.....	80	70
Tactical employment, general.....	71	42
Chemical cloud:		
Area affected.....	74	45
Effect of wind.....	73	44
Minimum ammunition requirements.....	80	70
Tactical employment.....	71-74	42
Technique of travel.....	72	42
Chemical munitions:		
Description and use.....	65-70	34
General rules of employment.....	79	68
Chemicals, definitions.....	61	32
Cities:		
Centers of uprisings.....	48	25
Marching through streets.....	44	23
Methods of attack.....	43	23
Mopping up.....	45	24
Offensive action, general.....	42	22
Sniping.....	46	24

INDEX

	Paragraphs	Pages
Civil authorities, responsibility in time of war--	2	1
Civil disturbances, employment of troops, general-----	21	13
Civil government, restoring and sustaining-----	47	24
Cloud, chemical. (See Chemical cloud.)		
Commanding officer:		
Duties-----	50	26
Information furnished-----	49	25
Responsibility in emergency-----	3	2
Command, troops employed under orders of President-----	9	7
Communications, establishment in occupied parts of city-----	51	28
Constitution of United States, pertinent pro- visions-----	5	4
Crowds, defined-----	32	17
Crowd tactics-----	33	18
Defense of localities-----	38	21
Disorderly street gathering, illustrative problem--	77	48
Engineers, in riot duty-----	22	13
Equipment for riot duty-----	23	15
Examples illustrating use of chemicals-----	77, 78	48, 63
Federal troops. (See Troops.)		
Gas cloud. (See Chemical cloud.)		
Gas, defined-----	61	32
Habeas corpus, issue of writ-----	10	8
Hand grenades:		
Description and use-----	65, 67	34, 36
Factors governing use-----	74	45
Desirable in riot duty-----	24	15
Illustrative problems-----	77	48
Infantry, in riot duty-----	22, 35	13, 19
Information centers, establishment in occupied parts of city-----	51	28
Information, furnished military commander-----	49	25
Insurrections:		
Federal Government, application for troops unnecessary-----	7	6
State governments, application for troops-----	7	6
Intelligence service, establishment and opera- tion-----	52	28
Intolerable concentrations, defined-----	61	32
Irritant agent, defined-----	61	32
Local commander, responsibility for initial action-----	8	6
Machine guns, use in riot duty-----	34	18
Martial law:		
Compared with occasions of military aid----	15	10
Defined-----	11	9
Legal authority-----	12	9
Legal effects-----	14	10
Proclamation-----	13	10

INDEX

	Paragraphs	Pages
Military commander. (See Commanding officer.)		
Military personnel:		
Conduct toward civilians.....	56	29
Excessive or malicious violence.....	18	11
Police functions.....	59	30
Protection in chemical operations.....	75	47
Responsibility in case of palpable illegality of order.....	17	11
Right to trial by Federal court.....	19	12
Rule of conduct.....	20	12
Mob determined upon lynching a prisoner, illus- trative problem.....	77	48
Mobs, defined.....	32	17
Mob tactics:		
Formations of troops.....	35	19
Methods employed against.....	34	18
Mopping up, after taking of city.....	45	24
Mounted men, moral effect created by.....	22, 40	13, 22
Munitions:		
Chemical, general.....	65	34
Marking.....	66	35
Patrols:		
Establishment of foot, mounted, and motor.....	58	30
Prescribed routes.....	58	30
Police functions, exercise of by soldiers.....	59	30
Posse Comitatus Act, exceptions and effect.....	4	3
Pots, smoke:		
Description and use.....	70	41
Factors governing use.....	74	45
President of United States, authority to use Fed- eral troops.....	3	2
Private property, required for use of troops, how obtained.....	57	30
Problems illustrating use of chemical munitions.....	77, 78	48, 63
Proclamation of President:		
Action pending issuance.....	9	7
Martial law.....	13	10
Reconnaissance.....	53	29
Rifle grenades:		
Description and use.....	65, 68	34, 37
Factors governing use.....	74	45
Rioters, types of protective devices used by.....	76	47
Riot in a penal institution, illustrative problem.....	77	48
Scout cars, use.....	39	21
Smoke cloud. (See Chemical cloud.)		
Smoke pots. (See Pots, smoke.)		
Sniping in cities.....	46	24
Statutory authority:		
Denial by State of equal protection of laws.....	5	4
Federal aid for State governments.....	5	4
Hawaii, Puerto Rico.....	5	4
Posse Comitatus Act.....	4	3
Use of military and naval forces to enforce authority of Federal Government.....	5	4
Supplies, miscellaneous.....	26	15

INDEX

	Paragraphs	Pages
Tactics:		
Crowd.....	33	18
Mob.....	34	18
Troops employed in aid of civil authorities..	9	7
Variation in requirements of the situation..	31	17
Tanks, manner of employment.....	41	22
Traffic control, occupied cities.....	55	29
Transportation:		
Methods.....	27	15
Motor, need of.....	25	15
Precautions—		
At destination.....	20	12
Before starting.....	28	15
En route.....	29	16
Trial by Federal court, right of military person- nel.....	19	12
Troops:		
Application for.....	7	6
Authority for use.....	3	2
Employed in aid of civil authorities, gov- erned by Army Regulations.....	9	7
Employment in civil disturbances, general..	21	13
Transportation. (See Transportation.)		
Weapons.....	24	15





BASIC FIELD MANUAL

MILITARY LAW DOMESTIC DISTURBANCES

CHANGES }
No. 2 }

WAR DEPARTMENT,
WASHINGTON 25, D. C., 28 January 1944.

FM 27-15, 6 February 1941, is changed as follows:

■ 35. (Superseded) RIOT CONTROL FORMATIONS.—*a. General.*—

(1) Riot control formations are adaptations of combat formations suitable for use during civil disturbances. They are simple and flexible, and should be executed smoothly and precisely. Riot formations are generally assumed from column but are permissible from any disposition.

(2) The formations described herein are designed primarily for military police battalions. Other troops may employ or adapt formations prescribed in FM 22-5. Men not armed with the bayonet should be held behind the line. (See figs. 0.1 to 0.8, incl.)

(3) Before assuming formation, bayonets will be fixed. The movement will be executed at HIGH PORT until the command ON GUARD is given.

(4) The fundamental formations used in riot control are the wedge, the diagonal (to right or left), and line. (See fig. 0.1.) Other effective formations may be obtained by doubling, extending, or combining the basic formations. The normal interval and distance between men in formation will be 1 pace (fig. 0.1), but may be changed as required by the individual situation.

(5) The hand signals prescribed in chapter 11, FM 22-5, may be used where applicable.

b. The squad.—(1) *Squad wedge* (fig. 0.2).—The command is: 1. SQUAD WEDGE, 2. MOVE. At the command or signal MOVE, usually given from squad column, but permissible from any disposition, the sergeant takes one step to the right. No. 2 advances to a spot designated by the squad leader. Nos. 3, 5,

*This change printed as a pamphlet to conserve paper and printing and to expedite delivery to the field.

7, and 9 align themselves on the No. 2 man, 1 pace to the left and 1 pace to the rear of each preceding man. No. 4, 6, 8, and 10 align themselves on the No. 2 man, 1 pace to the right and 1 pace to the rear of each preceding man. No. 11 takes position within the wedge in rear of No. 5. The squad leader takes a position within the wedge where he can best control the squad. The corporal, armed with an automatic weapon, takes position within the wedge in rear of No. 6.

(2) *Squad diagonal right (or left)* (fig. 0.3).—The command is: 1. SQUAD DIAGONAL RIGHT (OR LEFT), 2. MOVE. At the command or signal MOVE, usually given from squad column, but permissible from any disposition, Nos. 3, 4, 5, 6, 7, 8, 9, and 10 align themselves on the No. 2 man, 1 pace to the right (or left) and 1 pace to the rear of each preceding man. No. 11 takes position in rear of No. 5. The corporal takes position in rear of No. 8. The squad leader places himself in rear where he can best control the squad.

(3) *Squad line* (fig. 0.4).—The command is: 1. AS SKIRMISHERS (1 PACE), 2. MOVE. At the command or signal MOVE, the squad deploys as prescribed in FM 22-5. The squad leader and men armed with automatic weapons form in rear of the squad.

(4) *To re-form the squad from any formation*.—The command is: ASSEMBLE. The No. 2 man assumes the position of HIGH PORT facing in the designated direction. The remaining men of the squad, at HIGH PORT and in DOUBLE TIME, form in their respective positions behind No. 2. When the squad is assembled, the squad leader takes his position.

c. *The platoon*.—(1) *Platoon wedge* (fig. 0.5).—The command is: 1. PLATOON WEDGE, 2. MOVE. At the command or signal MOVE, the center squad of the platoon, the base squad, executes right by two's. The right and left squads advance 6 paces and execute DIAGONAL RIGHT and LEFT respectively. The platoon leader and platoon sergeant take positions where they can best control the platoon.

(2) *Platoon diagonal right (left 1)*.—The command is: 1. PLATOON DIAGONAL RIGHT, (LEFT), 2. MOVE. (See fig. 0.6.) At the command MOVE, the left squad of the platoon, which is the base squad, executes SQUAD DIAGONAL RIGHT. The squads on the right move by the most direct route and deploy in the SQUAD

DIAGONAL formation, on the right of the base squad, and in prolongation of the line formed by that squad.

(3) *Platoon in line* (fig. 0.7).—The command is: 1. AS SKIRMISHERS (1 PACE), 2. MOVE. The platoon deploys as prescribed in FM 22-5. Squad leaders and men armed with automatic weapons form in rear of their respective squads and place themselves on a prolongation of the line formed by the base squad. The squad leaders take positions in the rear of their squads. The platoon sergeant takes a position where he can best observe.

(4) *Platoon (1) arrow* (fig. 0.8).—The command is: 1. PLATOON ARROW, 2. MOVE. At the command or signal MOVE, the center squad executes CLOSE SQUAD COLUMN. The right and left squads advance 6 paces and execute **DIAGONAL RIGHT** and **LEFT** respectively. The platoon leader and platoon sergeant take positions where they can best control the platoon.

(5) *To re-form platoon from any formation*.—The command is: ASSEMBLE. The No. 2 man of the base squad halts if moving and assumes the position of **HIGH PORT**. The remainder of the squad form behind him in their respective places and assume the position of **HIGH PORT**. The No. 2 men of the exterior squads place themselves abreast of No. 2 of the base squad at the extended interval; the remaining men of the exterior squads form in their respective places behind the No. 2 man. When his squad is assembled, the squad leader takes his place in front of his squad. The platoon leader and platoon sergeant place themselves at the head of the platoon.

d. The company.—Company riot control formations are combinations of the basic formations. Each unit of the company is deployed in the formation which is suitable to its mission.

[A. G. 300.7 (20 Aug 43).] (C 2, 28 Jan 44.)

Interval and Distance

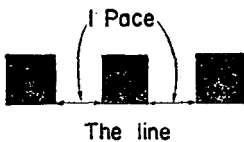
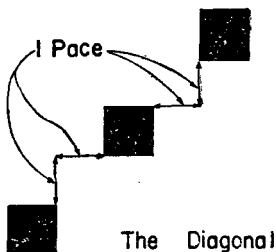
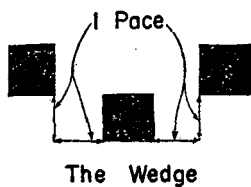

FIGURE 0.1.—All formations—normally 1 pace.

[A. G. 300.7 (20 Aug 43).] (C 2, 28 Jan 44.)

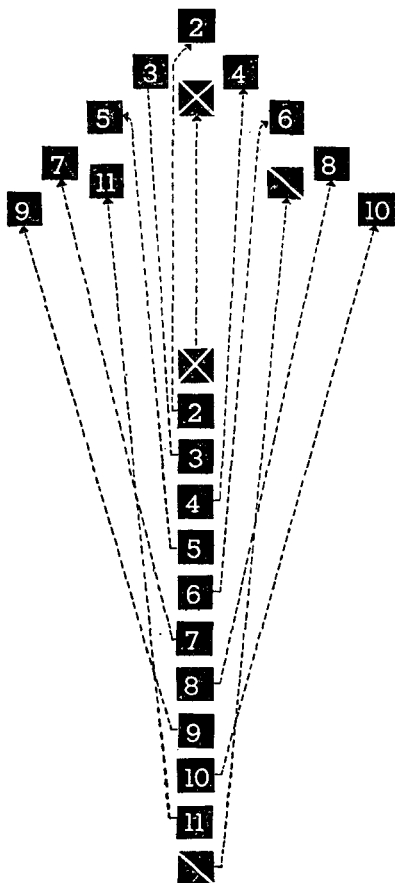

FIGURE 0.2.—Squad wedge.

[A. G. 300.7 (20 Aug 43).] (C 2, 28 Jan 44.)

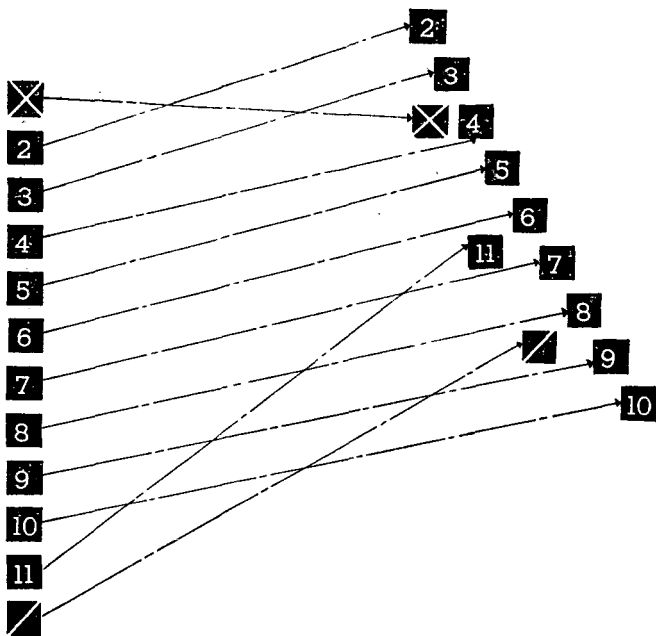

FIGURE 0.3.—Squad diagonal.

[A. G. 300.7 (20 Aug 43).] (C 2, 28 Jan 44.)

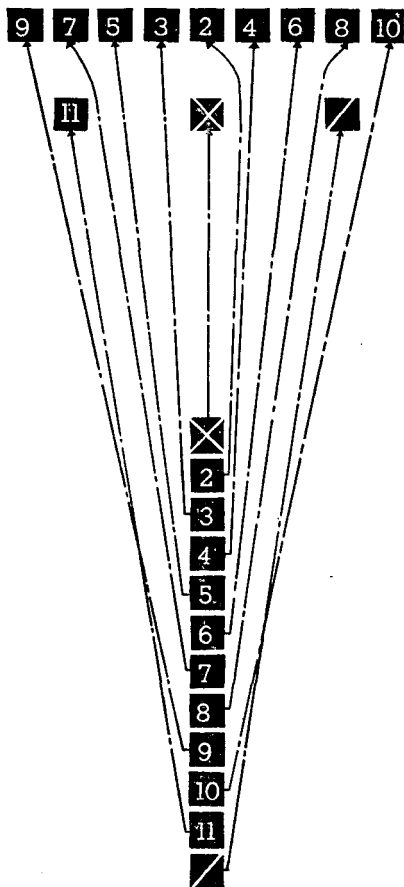

FIGURE 0.4.—Squad line.

[A. G. 300.7 (20 Aug 43).] (C 2, 28 Jan 44.)

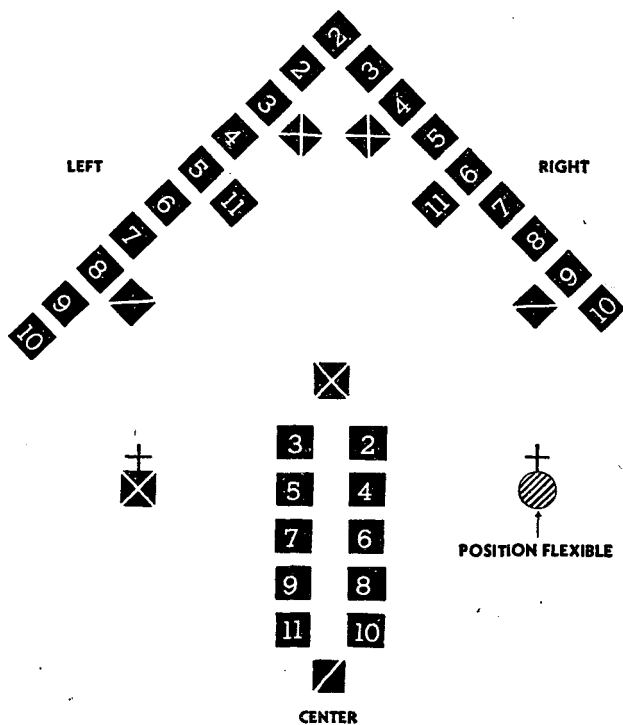

FIGURE 0.5.—Platoon wedge.

[A. G. 300.7 (20 Aug 43).] (C 2, 28 Jan 44.)

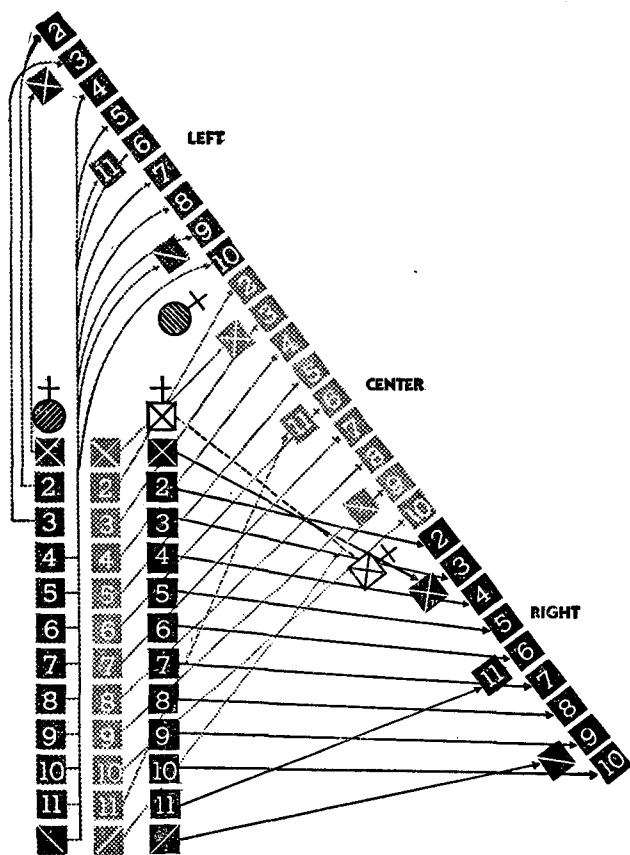

FIGURE 0.6.—Platoon diagonal (right).

[A. G. 300.7 (20 Aug 43).] (C 2, 28 Jan 44.)

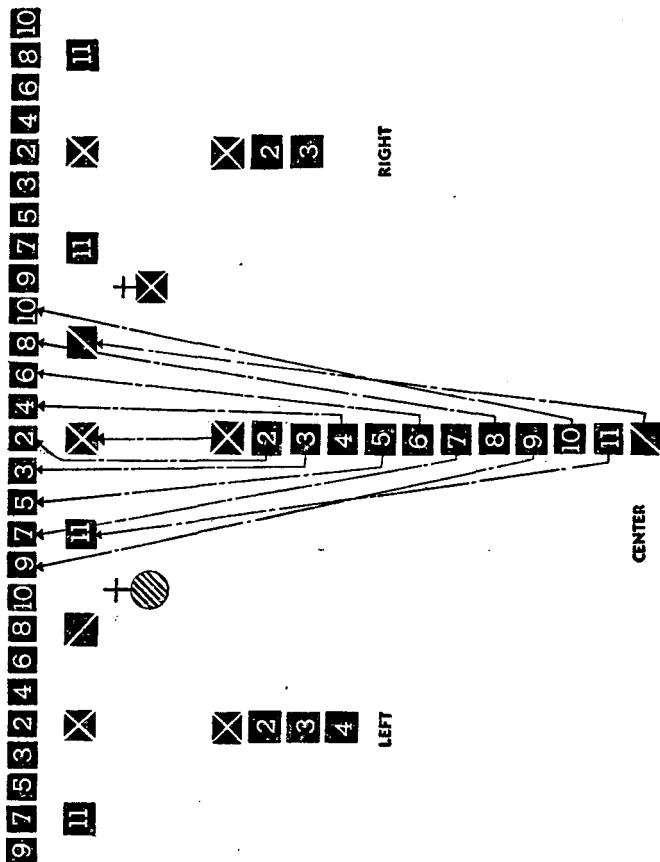

FIGURE 0.7.—Platoon line.

[A. G. 300.7 (20 Aug 43).] (C 2, 28 Jan 44.)

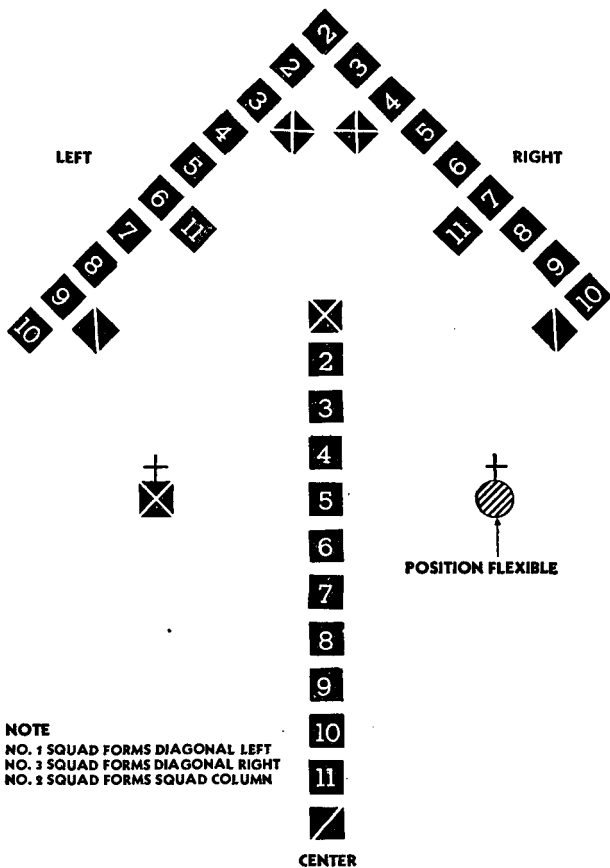

FIGURE 0.8.—Platoon arrow (wedge).

[A. G. 300.7 (20 Aug 43).] (C 2, 28 Jan 44.)

FM 27-15

C 2

BASIC FIELD MANUAL

BY ORDER OF THE SECRETARY OF WAR:

G. C. MARSHALL,
Chief of Staff.

OFFICIAL:

J. A. ULIO,
Major General,
The Adjutant General.