

**MHI
COPY**

MHI
Copy 3

120 yds
170
FM 4-15

WAR DEPARTMENT

**COAST ARTILLERY
FIELD MANUAL**

•

**SEACOAST ARTILLERY
FIRE CONTROL
AND
POSITION FINDING**

FM 4-15

**COAST ARTILLERY
FIELD MANUAL**

**SEACOAST ARTILLERY
FIRE CONTROL
AND
POSITION FINDING**

Prepared under direction of the
Chief of Coast Artillery



UNITED STATES
GOVERNMENT PRINTING OFFICE
WASHINGTON: 1916

For sale by the Superintendent of Documents, Washington, D. C. - Price 50 cents

WAR DEPARTMENT,
WASHINGTON, *July 29, 1940.*

FM 4-15, Coast Artillery Field Manual, Seacoast Artillery, Fire Control and Position Finding, is published for the information and guidance of all concerned.

[A. G. 062.11 (5-7-40).]

BY ORDER OF THE SECRETARY OF WAR:

G. C. MARSHALL,
Chief of Staff.

OFFICIAL:

E. S. ADAMS,
Major General,
The Adjutant General.

TABLE OF CONTENTS

	Paragraphs	Page
CHAPTER 1. GENERAL.....	1-4	1
CHAPTER 2. INDICATION AND IDENTIFICATION OF NAVAL TARGETS.....	5-9	2
CHAPTER 3. FIRE-CONTROL AND POSITION FINDING SYSTEMS.		
Section I. General.....	10	7
II. Azimuth measurement.....	11-12	8
III. Tracking.....	13-18	9
IV. Prediction.....	19-20	14
CHAPTER 4. FIRING DATA.....	21-25	16
CHAPTER 5. DISPLACEMENT.		
Section I. General.....	26-27	21
II. Azimuth difference.....	28-31	21
III. Range difference.....	32-33	29
IV. Elevation difference.....	34-35	31
V. Gun displacement.....	36-37	35
CHAPTER 6. TIMING OF POSITION FINDING SYSTEM.	38-40	38
CHAPTER 7. OBSERVATION INSTRUMENTS.		
Section I. General.....	41	41
II. Azimuth instruments.....	42-43	41
III. Depression position finders.....	44-47	46
IV. Self-contained base instruments..	48-51	58
CHAPTER 8. REFERENCE NUMBERS.....	52-56	72
CHAPTER 9. PLOTTING BOARD ACCESSORIES.		
Section I. Prediction scale.....	57-58	74
II. Set-forward rule.....	59-61	75
III. Set-forward chart.....	62-63	78
IV. Set-forward scales.....	64-65	79
V. Targ.....	66	83
CHAPTER 10. PLOTTING BOARDS.		
Section I. Plotting board, M1904 (Whistler- Hearn).....	67-69	84
II. Mortar plotting boards.....	70-71	92
III. 110° plotting boards, M1915, M1918, and M3.....	72-74	93
IV. Plotting and relocating boards, M1923 (Clove) and M1.....	75-77	98
CHAPTER 11. RANGE CORRECTION DEVICES.		
Section I. General.....	78-79	112
II. Wind component indicator.....	80-82	116
III. Range correction board M1.....	83-86	119
IV. Other models of range correction boards.....	87-90	123
V. Percentage corrector M1.....	91-92	124

TABLE OF CONTENTS

	Paragraphs	Page
CHAPTER 12. DIRECTION CORRECTION DEVICES.		
Section I. General.....	93	131
II. Deflection board, M1905 (for guns).....	94-96	132
III. Deflection board, M1906 (for mortars).....	97-100	141
IV. Universal deflection board.....	101-104	145
V. Angular travel computer.....	105-106	151
VI. Deflection board M1.....	107-110	154
VII. Azimuth adjustment slide rule.....	111-112	167
CHAPTER 13. SPOTTING SYSTEMS AND DEVICES.		
Section I. General.....	113-117	169
II. Earlier types of spotting boards.....	118-120	174
III. Spotting board M2.....	121-126	178
IV. Three-station spotting.....	127	183
V. Aerial spotting.....	128-135	184
CHAPTER 14. FIRE ADJUSTMENT DEVICES.		
Section I. Fire adjustment board M1.....	136-139	189
II. Bracketing adjustment chart.....	140-142	194
CHAPTER 15. AERIAL FIRE CONTROL.		
Section I. General.....	143	201
II. Functioning of an aerial fire control system.....	144-148	202
CHAPTER 16. EMERGENCY ONE-STATION FIRE CONTROL SYSTEM.	149-154	209
CHAPTER 17. POINTING METHODS AND INSTRUMENTS.		
Section I. General.....	155-158	215
II. Pointing in elevation.....	159-168	216
III. Pointing in direction.....	169-176	228
IV. Examples of pointing adjustments.....	177-180	245
CHAPTER 18. FIRE CONTROL COMMUNICATION.....	181-188	258
CHAPTER 19. ORGANIZATION AND DUTIES OF RANGE SECTION AND OF OTHER BATTERY FIRE CONTROL PERSONNEL.		
Section I. Range section, general.....	189-191	266
II. Duties of range section details.....	192-194	269
III. Other battery fire control personnel.....	195-197	274
IV. Training.....	198-206	276
CHAPTER 20. FUNCTIONING OF FIRE CONTROL AND POSITION FINDING SYSTEMS.		
Section I. General.....	207	281
II. Action before target is assigned.....	208	282
III. Action when target is assigned.....	209-211	283
IV. Functioning when using other equipment.....	212-215	286
V. Functioning of spotting system.....	216	287
APPENDIX I. Glossary.....		289
II. Construction of charts and scales for seacoast artillery fire control instruments.....		297
III. Derivation of formulas for spotting board M2.....		323
IV. Data.....		325
V. List of references.....		327
INDEX.....		329

COAST ARTILLERY FIELD MANUAL

SEACOAST ARTILLERY

FIRE CONTROL AND POSITION FINDING

(The matter contained herein supersedes sections IV and V, chapter 1, and chapter 2, part two, volume I, Coast Artillery Field Manual, February 1, 1933.)

CHAPTER 1

GENERAL

- 1. **PURPOSE.**—The purpose of this manual is to provide a guide for the technical training of the personnel employed in the determination and application of firing data for sea-coast artillery.
- 2. **SCOPE.**—This manual covers the principles of position finding, including the design and operation of all instruments and devices used by the position finding details, and the pointing details on the guns, as well as the functioning of that personnel as a whole. In addition, appendix II contains information on the construction of charts and scales used on seacoast artillery fire control instruments which will facilitate verification of those charts and scales or construction of new charts and scales when necessary. Data especially applicable to fire control and position finding for seacoast artillery are contained in appendix IV. Other useful and more general data are contained in FM 4-155. The contents of the manual apply to both fixed and mobile sea-coast artillery. As soon as mobile weapons are emplaced in position for firing at naval targets, the principles of this subject, as laid down for permanently fixed weapons, apply.
- 3. **REFERENCES.**—More detailed information on fire-control instruments and on related subjects may be found in the references listed in appendix V.
- 4. **DEFINITIONS.**—There are certain terms used throughout the manual the meaning of which should be understood before *beginning a study* of the text. These appear in the glossary, appendix I, which should be read carefully before proceeding with the study of this manual.

CHAPTER 2

INDICATION AND IDENTIFICATION OF NAVAL TARGETS

■ 5. GENERAL.—Identification, indication, and assignment of the target are of primary importance. Any system used must be simple, positive, and universal in its application, so that when a commander assigns a target there will be in the mind of the subordinate no doubt as to the target intended. A knowledge of the characteristics and of the appearance of each of the various types of vessels, both war and commercial, is necessary to their ready identification by gun pointers, observers, and spotters. The various vessels of war include battleships, battle cruisers, aircraft carriers, cruisers, destroyers, submarines, supply ships, fuel ships, tenders, mine layers, and mine sweepers. They may best be identified at long range by their silhouettes—the outline of the solid features of the ship as seen at a distance. Silhouettes of warships may be found in pertinent standard works or in training film slides. Silhouettes for all possible targets should be prepared and posted in the various stations of harbor defense commands. Silhouettes are often classified for convenience by using the number of funnels and masts as a basis; for example, class 1-2, where the first digit (1) indicates the number of funnels, and the second digit (2), the number of masts. (See fig. 1.)

■ 6. HARBOR DEFENSE WATER AREAS.—*a.* In order that targets may be indicated it is necessary that the water areas adjacent to a harbor defense be subdivided. The method of accomplishing this subdivision will vary in different harbor defenses depending upon the geography and hydrography. A typical method is shown in figure 2. If the harbor defense shown included forts at one or more of the islands, each fort would make its own subdivision, and the harbor defense commander, in assigning a target from his command post to a groupment or group at one of these islands, would

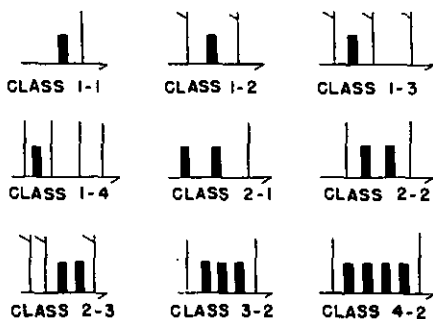

FIGURE 1.—Classification of ships for identification.

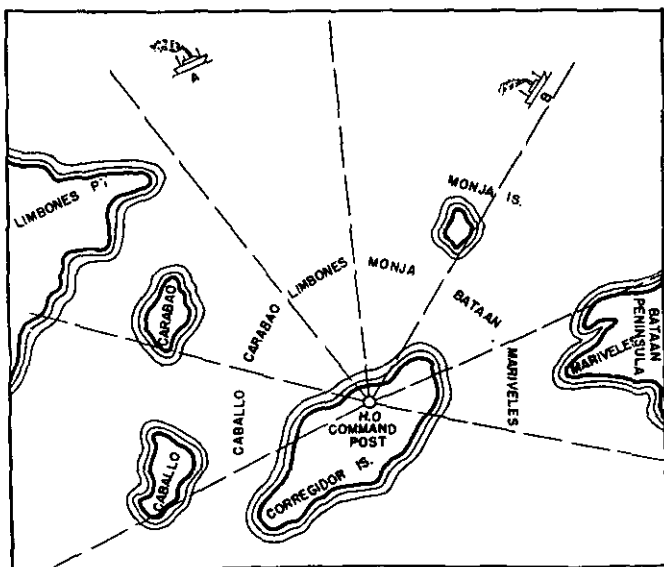

FIGURE 2.—Subdivision of harbor defense water area.

relocate and indicate the target with respect to the subdivisions of that fort.

b. (1) In assigning target A, figure 2, to groups on Corregidor Island, the harbor defense commander would indicate it, TARGET, LIMBONES; in assigning target B, TARGET, MONJA. If there were more than one ship in the Monja subarea it would be necessary to indicate the target more exactly. Thus, target B might be indicated, TARGET, MONJA RIGHT, directing attention to a particular target toward the right limit of the Monja subarea. The commander must be as definite as necessary in his indication of the target. Where there are several targets of the same type in the same subarea, the commander may give the approximate azimuth and range of the particular target, the target in this case being relocated so that the azimuth and range given will locate the target with reference to the station or battery to which assigned. Thus, target B might be indicated, TARGET, MONJA RIGHT, AZIMUTH 135, RANGE 6,600.

(2) Another method of relocating a target is by reference to an oriented grid which has been superimposed on maps of a water area or subarea. A system which has been used is one in which large squares which are lettered are subdivided into smaller squares which are numbered. The grid system has the advantage that the target appears in the same area from all stations, and its apparent location does not depend on the point of view of each particular observer. Typical target indications using such a system would be, TARGET, A14 and TARGET, B26.

■ 7. CONTENTS OF COMMANDS.—Commands employed in indicating and assigning a target to subordinate units contain the following elements which should be given in the order indicated:

a. *Units.*—The unit or units to which the command is addressed, as ALL GROUPS, GROUP 2, ALL BATTERIES, or BATTERY SMITH. This element alerts the unit or units addressed. It is omitted when unnecessary, such as by the commander of the lowest unit (the battery) in commands to his unit.

b. *Target.*—The word TARGET quickly informs the commander of the lower unit that a target is about to be designated or assigned.

c. *Water area.*—The name of the water area or subarea or the letter and number of the square in which the target is located.

d. *Designation of target.*—This element of the command will include such of the following information as may be necessary:

(1) For an isolated ship, the type, as **BATTLESHIP**.

(2) For a ship which is part of a formation, the type, unit, formation, and the number of the ship in the formation, as **CRUISER DIVISION, LINE, SHIP NO. 2**. (Ships are numbered in column from the leading ship; if not in column, from the starboard (right) ship of the formation with reference to the direction in which the formation is headed.)

(3) The classification as to funnels and masts (not usually given for war vessels).

(4) In night operations, the number of the covering searchlight, as **IN BEAM OF NO. 4**.

(5) The direction of movement of the target, as **COMING IN, GOING OUT, MOVING FROM LEFT TO RIGHT, OR MOVING NORTH**.

(6) Any other description necessary for prompt and positive identification.

e. *Designation of position finding system and stations to be used.*—This element of the command is given by the battery commander when a system other than the normal system is to be employed, for example, **VERTICAL BASE, B-SECOND** (the secondary base end station).

f. *Track.*—The command **TRACK** is given by a battery officer to position finding personnel to initiate the operation of tracking. (See par. 13.)

g. *Other commands.*—Such additional commands for firing or other action as may be appropriate. (If appropriate, commands given by the battery commander may be preceded by the command **BATTERY ATTENTION**.)

■ **8. EXAMPLES OF COMMANDS.**—The following are examples of commands (dashes indicate pauses to allow for the repetition of the command by receiving personnel):

TARGET -----; OCEAN VIEW -----; BATTLESHIP, COMING IN -----; IN BEAM OF NO. 6 -----; COMMENCE FIRING WHEN IN RANGE.

TARGET -----; LYNNHAVEN, RIGHT -----; OIL TANKER, CLASS 1-3, GOING OUT -----; ALTERNATE BASE, B¹-B³ -----; (observers, spotters, and gun pointers report "on target"); TRACK.

TARGET -----; MARIVELES, RIGHT -----; DESTROYER DIVISION, LINE, MOVING NORTH -----; SHIP NO. 1 -----; VERTICAL BASE B¹ -----; (observers, spotters, and gun pointers report "on target"); TRACK.

TARGET -----; B-20 -----; AIRCRAFT CARRIER, MOVING WEST -----; TRACK.

Note.—Grouping of naval vessels into units and their formations for maneuver and for battle are covered in FM 4-5.

■ 9. OBSERVING AND AIMING POINT.—The observing and aiming point for observers, gun pointers, and spotters should be some prominent feature of the target with which the vertical wire of the telescope can be readily aligned. Unless otherwise designated by the officer assigning the target, the observing and aiming point will be as follows:

- a. For vessels having one funnel—that funnel.
- b. For vessels having two funnels—the rear funnel.
- c. For vessels having three funnels—the center funnel.
- d. For vessels having four funnels—the third funnel.
- e. For vessels having masts but no funnels—the appropriate mast selected according to the plan illustrated in *a*, *b*, *c*, and *d* above for funnels.
- f. For other vessels—the point designated by the officer assigning the target.

CHAPTER 3

FIRE CONTROL AND POSITION FINDING SYSTEMS

	Paragraphs
SECTION I. General	10
II. Azimuth measurement.....	11-12
III. Tracking.....	13-18
IV. Prediction	19-20

SECTION I

GENERAL

■ 10. GENERAL.—*a.* The function of a fire control and position finding system is to furnish data in the proper form for use in pointing the guns of a battery for firing at a target. In seacoast artillery, the guns must be pointed at a moving target. The ideal system would furnish firing data instantaneously and continuously. With the present standard plotting room and data transmitting equipment, the operation is neither instantaneous nor continuous. There is a lapse of time between the instant an observation is taken on a target and the instant the guns are fired with the firing data that were calculated as a result of that observation. This interval is called the "dead time." Its length depends on the time necessary to calculate the firing data with the desired accuracy and apply them to the guns.

b. In a 3-inch rapid fire battery, case I or case II pointing (par. 158) is used. The ranges and times of flight are short and the dead time is negligible. The problem of determining firing data is comparatively simple, a self-contained range finder and a gun sight being used.

c. For a battery of 6-inch caliber or larger the operation of determining firing data for a moving target may be divided into the following steps:

(1) Tracking—which includes observing and plotting successive positions of the target.

(2) Location of set-forward point—which consists of predicting the future position of the target, that is, its predicted position at the end of the predicted time of flight.

(3) Relocation—which consists of determining the range and direction of the future position of the target from the directing point.

(4) Calculation of firing data—which consists of converting the relocated data into corrected firing data for use in pointing the guns.

d. Excessive dead time would afford the target undue opportunity to avoid the fire by maneuvering. On the other hand too short a dead time would not permit performance of the necessary operations with suitable accuracy. (See also par. 39.) A satisfactory fire-control and position finding system must be based on the principles of simplicity of method and of operation.

e. The three standard systems of position finding in use by seacoast artillery are the horizontal base, vertical base, and self-contained base systems. In all of these systems the procedure is similar. They differ only in the method of locating the target in tracking. At least two standard systems are usually made available for each battery. The standard systems may be supplemented by alternate systems consisting of different combinations of elements of the standard systems. The personnel of a battery should be trained and prepared to use all of the standard systems and alternate systems.

SECTION II

AZIMUTH MEASUREMENT

■ 11. ANGULAR SYSTEM.—In all standard position finding systems, one of the elements of the data measured in locating the position of the target is called the "azimuth." Azimuth is the horizontal angle measured in a clockwise direction from a selected reference line, passing through the position of the observer, to the horizontal projection of the line of sight from the observer to the objective (in this case, the target). For seacoast artillery, the reference line is a horizontal line parallel to the true south line at the origin of the coordinates. (See *TM 4-225.) Any instrument which will correctly measure horizontal angles will measure azimuths.

* See appendix V.

■ 12. ANGULAR UNITS.—The angular unit of measurement of all horizontal angles for all seacoast artillery, except as stated below for certain 155-mm guns, is the degree, an angle which is one three-hundred-sixtieth ($1/360$) part of a circle. Azimuths expressed in degrees are measured to the nearest one one-hundredth (0.01) of a degree. The angular unit of measurement of all horizontal angles for 155-mm guns which have not been modified to use the degree system (see note) is the mil, an angle which is one sixty-four-hundredth ($1/6400$) part of a circle. Azimuths expressed in mils are measured to the nearest mil. Thus, a degree is equal to 17.778 mils, and 9 degrees is equal to 160 mils. For practical purposes, in small angles, a mil may be taken as the angle which intercepts an arc (or chord) equal to one one-thousandth ($1/1000$) of the range; for example, at 10,000 yards one mil intercepts approximately 10 yards.

NOTE.—As rapidly as funds permit, all sighting and other equipment for seacoast artillery using the mil as the azimuth unit will be replaced with new or modified equipment using degrees and hundredths.

SECTION III

TRACKING

■ 13. PRINCIPLES COMMON TO ALL SYSTEMS.—The first step in all position finding systems is the location of the position of the target with respect to the observation stations of the battery. This operation is called "tracking" and consists of locating at regular intervals of time (see note) by observation from one or more stations, successive positions of the target, and plotting those positions on a plotting board. The time interval between successive observations is called the "observing interval" and is 15 to 20 seconds in length. The observing intervals are indicated by TI (time interval) bells or buzzers which sound simultaneously in all stations of the battery.

NOTE.—In aerial fire control (ch. 15), the observing intervals are irregular, are longer than 20 seconds, and are not marked by TI bells or buzzers.

■ 14. HORIZONTAL BASE SYSTEM.—*a. Description.*—(1) In the horizontal base system, the target is located by the method

of intersection used in surveying in which the direction of the target from two known points is determined. In the triangle involved, one side and the two adjacent angles are known. The solution is made graphically on the plotting board. The system requires a base line on the ground, the azimuth and length of which have been accurately determined by surveying (see* TM 4-225); two observation stations, one at each end of the base line, in each of which is mounted an instrument for measuring azimuths; a plotting board; and the necessary communication lines.

(2) The plotting board represents to scale the field of fire of the battery. On it are located to scale in their proper relation to each other the observation stations, the base line, and the directing point (the point for which the firing data are to be determined). Figure 3 illustrates the relation between the installations in the field and the set-up on the plotting board.

(3) The observation station nearest the directing point is usually called the primary station. The station at the other end of the base line is called the secondary station. The base line of a horizontal base system is called "right-handed" or "left-handed," according to whether the secondary station is to the right or to the left of the primary station, as viewed from behind the base line facing the field of fire.

(4) The base line for a horizontal base system should conform to the following principles:

(a) Its length should be from one-fourth to one-third of the maximum range to be measured by the base line.

(b) Its direction should be approximately perpendicular to the center line of the field of fire to be covered by the base line.

(c) The base end stations should have sufficient height above sea level to afford a field of view to seaward beyond the maximum range to be measured. (See app. IV.)

b. Operation.—The observers at the base end stations sight and follow with the vertical cross wires of their instruments the target assigned by the battery commander. At the sounding of each **TI** bell, the observers stop following the target

*See appendix V.

with their instruments while the readers read the azimuths and then resume tracking. Each reader is equipped with a telephone head set connecting him to an operator, called an "arm setter," in the plotting room. There the successive ob-

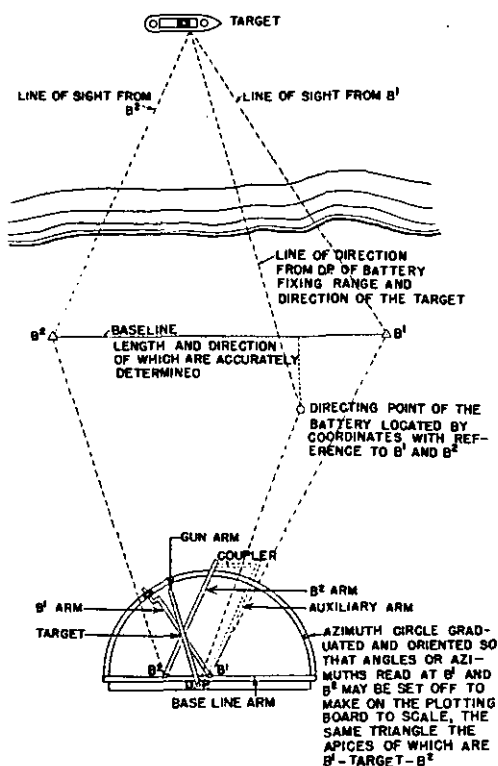

FIGURE 3.—Relation between plotting board and field of fire.

servations are plotted on the plotting board. The plotting board has an arm corresponding to each of two observation stations with a means of setting each arm in azimuth. Each arm setter sets his arm to the azimuth read by the corresponding reader. The point of intersection of the arms

represents the position of the target at the instant the observations were taken. This point is marked by the plotter. The operation is repeated at the sounding of each successive TI bell. The points are called "plotted points." A line joining the plotted points represents the track or path of the target.

■ 15. VERTICAL BASE SYSTEM—*a. Description.*—In the vertical base system, the target is located by the offset method used in surveying, in which the direction and distance of the target from a known point are determined. The direction is determined by reading the azimuth as in the horizontal base system. The distance is determined by the depression angle method which involves the solution of a vertical right triangle of which one leg is the desired range, the other leg is the effective height of the observation instrument above the target, and the hypotenuse is the line of sight from the observer to the target. The known angle is the complement of the angle between the hypotenuse and the known side, corrected for refraction. It is the angle through which the line of sight must be depressed from the horizontal to intersect the target and is called the depression angle. (See par. 44 and FM 4-10.) The triangle is solved mechanically by the observation instrument called a "depression position finder." This system requires but one observation station, the azimuth and range to the target being read from the same instrument.

b. Operation.—The observer tracks the target in azimuth with the vertical cross wire as in the horizontal base system. At the same time he tracks the target in range with the horizontal cross wire. In the plotting room, only one arm of the plotting board is used. The azimuth and range are received from the reader at each sounding of the TI bell. The arm setter sets the arm in azimuth and repeats the range to the plotter who marks the point at that range by means of range graduations along the edge of the arm.

■ 16. SELF-CONTAINED BASE SYSTEM—*a. Description.*—In the self-contained base system, the target is located by the offset method as in the vertical base system. The direction is determined by reading the azimuth as in the other systems. The range is determined by means of a self-contained range finder

of either the coincidence or the stereoscopic type. The principles of operation of these instruments are discussed in section IV, chapter 7.

b. Operation.—The operation of tracking with this system is similar to that with the vertical base system except that azimuths are usually read from a separate instrument. While it is more difficult to read ranges as the TI bell sounds in this system than in the vertical base system, observers can be trained to furnish ranges regularly on or sufficiently near the instant the TI bell sounds.

■ 17. ALTERNATE BASE LINES AND ALTERNATE STATIONS.—For batteries employing the horizontal base system, several alternate base lines frequently are provided in order that use

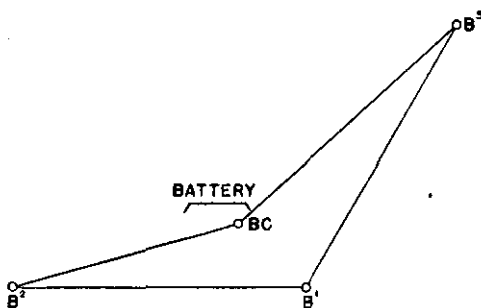

FIGURE 4.—Alternate base lines.

may be made of the base line allowing the greatest accuracy under existing conditions of visibility, target position, and target course. Figure 4 illustrates a set-up in which B^1-B^2 and B^1-B^3 are alternate base lines, all stations of which are accurately located. Those stations of the horizontal base system which have sufficient height of site are usually provided with depression position finders for use in a vertical base system, thus offering a choice of the most advantageous system and stations.

■ 18. EMERGENCY SYSTEMS.—Emergency systems possess features of reduced accuracy that are acceptable only under emergency conditions and are for use when all the normal

systems break down or are put out of action. Possible emergency methods include use of data determined from a station outside the battery—either a group command station or the directing point of an adjacent battery—and their conversion to suitable firing data by means of range difference and azimuth difference charts; use of aerial observation to determine initial data and to determine adjustment corrections thereto; and estimation of data from the guns by means of comparison with the known ranges and azimuths of reference points, such as buoys, in the field of fire, with subsequent adjustment as a result of observation of fire. An emergency one-station fire control system and an emergency aerial fire control system are described in chapters 16 and 15, respectively.

SECTION IV

PREDICTION

■ 19. LOCATION OF SET-FORWARD POINT.—The point for which firing data are calculated is called the "set-forward point." This point must be located on the expected path of the target and far enough in advance of the last plotted point to allow for the travel of the target during the time that will elapse between the moment the last observation was taken and the instant of the impact of the projectile. In order to locate the set-forward point, then, three things must be determined—the expected path of the target, the elapsed time (T), and the rate of travel (R) during that time. The rate multiplied by the time will give the desired distance along the expected path of the target from the last plotted point to the set-forward point. This information cannot be determined exactly but may be approximated to a satisfactory degree of accuracy from the plotted positions of the target by assuming that the target will continue to travel during the time T in the same direction and at the same speed as it did during the last observing interval. The expected path of the target will then be a prolongation of the plotted path, and the rate R will be the yards of travel during the observing interval divided by the interval in seconds. The time T consists of the dead time plus the time of flight. The necessary

amount of dead time for the system is selected in advance. The only requisite is that the time allowance be sufficient for the performance of all the operations required. The guns are usually fired as the bell sounds, in which case the dead time is the same as, or is some multiple of, the observing interval. (For a further discussion of the timing of a position finding system, see ch. 6.) The time of flight depends on the range to the set-forward point and may be determined quite closely by a series of successive approximations, but the usual procedure is to use a time of flight corresponding to the range to the last set-forward point. This introduces

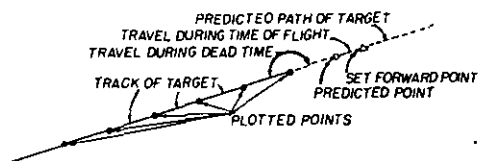

FIGURE 5.—Diagram of various positions of target.

only a small error if the predicting interval is reasonably short. In practice, this prediction is done with some form of prediction scale or set-forward device that eliminates mathematical calculation. (See ch. 9.)

■ 20. LOCATION OF PREDICTED POINT.—Sometimes (in mortar fire only) the predicted positions of the target at the end of the dead time (at the instant the gun is to be fired) are plotted on the board. These points are called "predicted points." A comparison of the location of a predicted point with that of the corresponding plotted point serves as a check on the accuracy of location of the predicted point. A better method of checking is described in paragraph 205.

CHAPTER 4

FIRING DATA

■ 21. ELEMENTS OF UNCORRECTED FIRING DATA (fig. 6).—The set-forward point having been located on the plotting board, a direction and a distance must be determined that may be used for or may be transformed into suitable data for the actual pointing of the gun. These data are called "uncorrected firing data."

a. It is obvious that a gun must be pointed in direction. This may be accomplished by either direct or indirect methods. If the target can be seen from the gun, the gun sight may be used. The sight may be pointed at the target and the gun set to diverge from the line of sight by the amount of the angular travel during the time of flight and fired at the expiration of the dead time. If the target cannot be seen from the gun, the gun is pointed in azimuth at the azimuth of the set-forward point and fired at the expiration of the dead time as before. In the first method, used in case I and in case II pointing, the desired element of the firing data is the uncorrected deflection; in the second method, used in case III pointing, the desired element is the uncorrected azimuth. From figure 6 it may be seen that in both cases the gun is pointed in the same direction.

b. In addition to being pointed in direction, the gun must be pointed so that the projectile will fall at the desired distance from the gun. This may be done by varying the angular elevation of the gun and, since the horizontal may be readily established, the elevation is measured from the horizontal. This is called the "quadrant elevation." If the relation between the range and the quadrant elevation can be established, the range to the set-forward point may be used as the other element of the uncorrected firing data. (This range elevation relation is published in firing tables by the Ordnance Department.) Hence, the other element of the uncorrected firing data is the uncorrected range. It is the same for all cases of pointing.

■ 22. DETERMINATION OF UNCORRECTED FIRING DATA.—*a. Case III pointing.*—In case III pointing, the uncorrected range and the uncorrected azimuth may be read from the plotting board by bringing the gun arm up to the set-forward point.

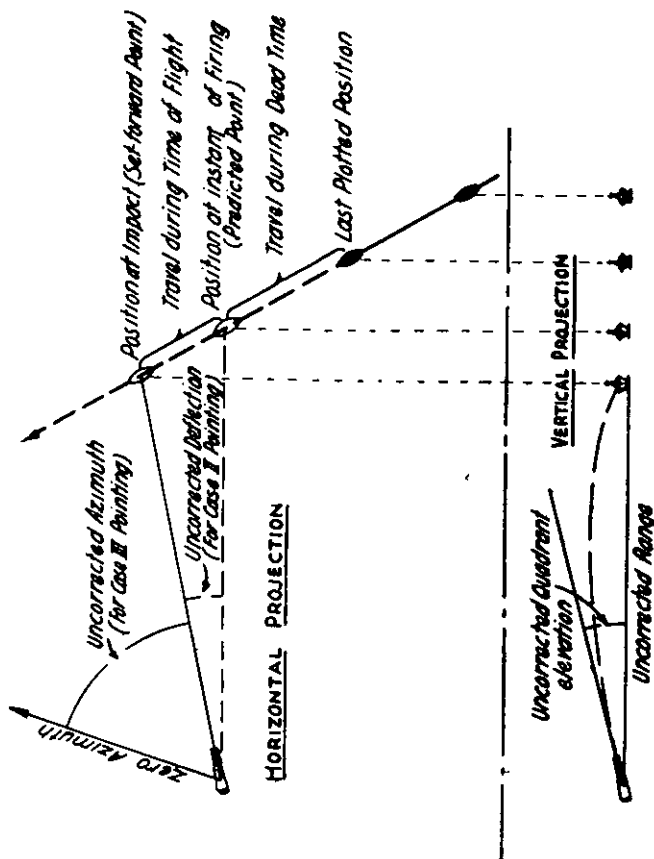

FIGURE 6.—Uncorrected firing data.

b. Case II pointing.—In case II pointing, the uncorrected range, being the same as for case III, may be read from the plotting board as before. The uncorrected deflection is

the angular travel of the target during the time of flight. To obtain it, there must be some means of determining the rate of angular travel of the target with respect to the directing point. That rate being known, it may be multiplied by the time of flight to the set-forward point. The range to the set-forward point having now been determined, the time of flight used in this operation is that corresponding to that range, as given in the firing tables. The rate of angular travel is determined from data obtained on the plotting board. The multiplication is performed graphically on either the deflection board or a special device called an angular travel computer. The functioning of these instruments is discussed in chapter 12.

■ 23. NECESSITY FOR CORRECTIONS FOR NONSTANDARD BALLISTIC CONDITIONS.—In order to compare the results of firings held at different times and places and take into account the conditions that actually exist at the time of firing, the range elevation relation is constructed for certain assumed ballistic conditions called "standard." Conditions at the battery at the time of a firing very seldom are exactly the same as those which are considered standard. Therefore it is necessary to consider and correct for those nonstandard conditions. To meet this problem, the firing tables include, in addition to the data for standard conditions, tables of differential effects by means of which necessary corrections may be made.

■ 24. CORRECTIONS TO RANGE.—*a.* Corrections to the range for the following nonstandard conditions are ordinarily made in the plotting room:

- (1) Variations in muzzle velocity (including temperature of powder).
- (2) Variations in atmospheric density.
- (3) Variations in atmospheric temperature (elasticity).
- (4) Height of site (including tide). (See note at the end of this paragraph.)
- (5) Wind.
- (6) Rotation of the earth (for long range guns).
- (7) Variations in weight of projectile.

b. These corrections are determined by a range correction board and are applied to the uncorrected range by an instrument called a "percentage corrector," the result being the firing range (or firing elevation) which is sent to the guns. Figure 7 (vertical projection) is a graphical representation of the application of corrections to the uncorrected range. In

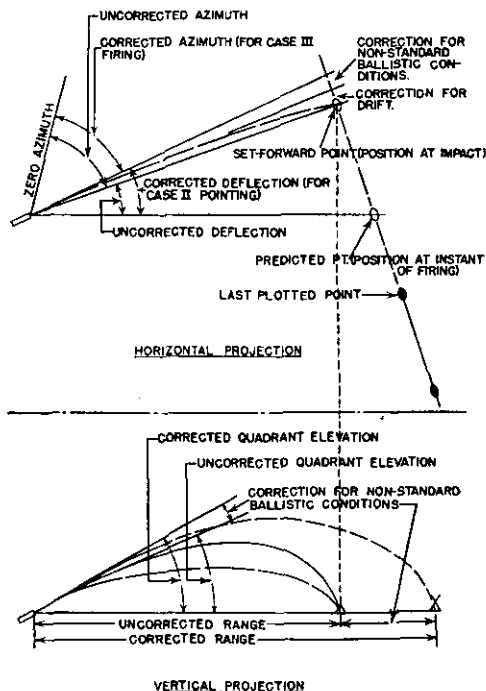

FIGURE 7.—Elements of corrected firing data.

this projection ballistic conditions were assumed to be such that it was necessary to lay the gun on point X in order to hit the target at the set-forward point.

NOTE.—For fixed seacoast batteries in which each gun is laid in range by means of a range disk, the height of site of each gun above the datum plane (mean low water) is known, and the

correction is incorporated in the graduations on the range disk on the gun. In such cases the correction for tide only is made in the plotting room. For mobile artillery which is pointed in range by setting elevations, and for guns equipped with an electrical data transmission system, the height of site correction is not made on the pointing equipment and therefore the correction for both height of site and tide must be made in the plotting room.

■ 25. CORRECTIONS TO AZIMUTH OR DEFLECTION.—*a.* To the azimuth or to the deflection shown in figure 6, corrections for drift and for the following nonstandard conditions are ordinarily made in the plotting room:

(1) Wind.

(2) Rotation of the earth (for long range guns).

b. These corrections are determined and applied to the uncorrected azimuth or deflection by a deflection board, the result being the firing azimuth (or firing deflection) which is transmitted to the guns. Figure 7 (horizontal projection) shows a graphical representation of the application of these corrections to the uncorrected firing data.

CHAPTER 5

DISPLACEMENT

	Paragraphs
SECTION I. General.....	26-27
II. Azimuth difference.....	28-31
III. Range difference.....	32-33
IV. Elevation difference.....	34-35
V. Gun displacement.....	36-37

SECTION I

GENERAL

■ 26. DEFINITIONS.—See glossary, appendix I, for pertinent definitions. The following terms should be understood before proceeding with the study of this chapter: relocation, azimuth difference, range difference, directing point, gun displacement, gun parallax, gun difference, elevation difference.

■ 27. RELOCATION.—In all the standard systems that employ the plotting board, relocation is performed mechanically on this instrument. It is accomplished by establishing the position of the directing point in the proper relation to that of the other points on the board and providing means for reading the azimuth and the range from the directing point to the target. However, it is sometimes necessary or desirable to relocate independently of the plotting board. Furthermore, it is often necessary, after having data referred to the directing point, to determine corrections to apply to these data in order to use them at other locations. The methods described in sections II to V, inclusive, are intended for use in these latter cases.

SECTION II

AZIMUTH DIFFERENCE

■ 28. APPROXIMATE FORMULAS.—In situations similar to that shown in figure 8, where the triangle formed is either right

or isosceles, and for values of the parallax angle of less than 400 mils, the relationship is

$$\text{Parallax (degrees)} = 57 \frac{AB}{AT};$$

or

$$\text{Parallax (mils)} = 1,000 \frac{AB}{AT}$$



FIGURE 8.—Azimuth difference (parallax). approximate formulas.

■ 29. GENERAL FORMULA.—For practical purposes the formula below is satisfactory for general use. In figure 9, *A* is a point from which the range and azimuth to *T* are known. It is desired to find the parallax angle $p (=BTA)$, having given the azimuth of *AB* and the displacement *d*.

$$\frac{\sin p}{AB} = \frac{\sin BAT}{BT}$$

But

$$AT = BT \text{ (approximately)}$$

Therefore

$$p = \sin^{-1} \frac{AB \sin BAT}{AT}$$

Angle *BAT* is obtained from the known azimuths of *AT* and *AB*.

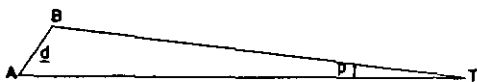

FIGURE 9.—Azimuth difference (parallax). general formula.

■ 30. AZIMUTH DIFFERENCE CHART, TYPE 1.—*a. General.*—The chart, figure 10, is actually a graphical solution of the general formula given in paragraph 29. It consists of equally spaced horizontal lines labeled in azimuth differences within an azimuth circle, and a rotating arm graduated in a particular manner with ranges. The device is operated simply

by setting the movable arm to the azimuth to the target and reading the azimuth difference from the horizontal line opposite the range.

b. Example.—Construct a graphical chart for the determination of azimuth differences for a point *B* when the ranges and azimuths to the target from a point *A* are known and the field of fire is from 100° to 290° . The azimuth from *A* to *B* is 280° and the distance *AB* is 100 yards. Since at any particular azimuth the azimuth difference is greatest when

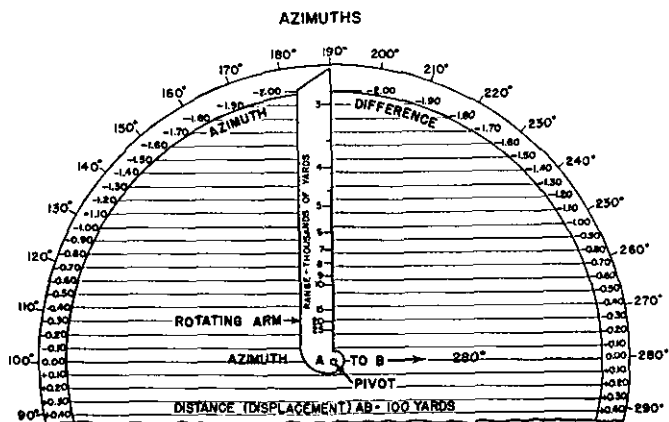

FIGURE 10.—Azimuth difference chart, type 1.

the range is shortest, the size of the chart required may be limited by selecting as the minimum range to be covered a range as great as practicable. For this example the minimum range is assumed to be 3,000 yards.

In figure 10 the horizontal lines are drawn first. Any convenient uniform spacing is used. There must be enough lines to accommodate the maximum azimuth difference. Since the azimuth difference for a given range is a maximum when the angle *BAT* is 90° , the number of lines required is determined by a solution of the general formula, using that

value of the angle and the value of the minimum range already selected. This solution is

$$\begin{aligned} p &= \sin^{-1} \frac{AB \sin BAT}{AT} \\ &= \sin^{-1} \frac{100 \sin 90^\circ}{3000} \\ &= \sin^{-1} 0.03333. \end{aligned}$$

Therefore $p=1.91^\circ$.

In figure 10 the horizontal lines are spaced at intervals each representing 0.10° of azimuth difference and lines up to 2.00° will be sufficient in this case. In practice the lines would be spaced at intervals representing 0.05° . To determine

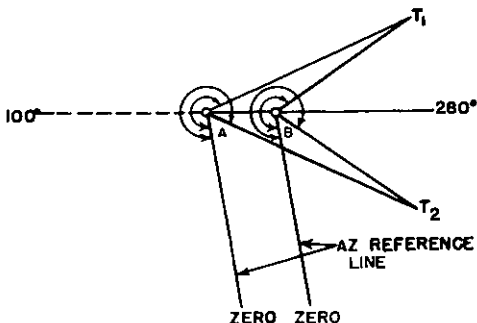

FIGURE 11.—Determination of sign of azimuth differences.

which azimuth differences are plus and which are minus, a simple sketch should be made. For the example given, figure 11 shows the situation. From this figure it can be seen that the azimuth of BT_1 is less than the azimuth of AT_1 , and the azimuth of BT_2 is greater than the azimuth of AT_2 . Plotting of other assumed target positions will show that the azimuth differences for all target azimuths above line AB (that is, between target azimuths 100° and 280°) are negative and those for all targets below AB (that is, between target azimuths 280° and 100°) are positive. Figure 10 is marked accordingly.

The azimuth circle is next drawn and graduated. It will be noted that the azimuth difference will be zero for all

ranges when the target is in prolongation of the line *AB*, which occurs at azimuths of 280° and 100°. The 280° graduation, therefore, is placed on the azimuth circle on the right side of the chart in prolongation of the line *AB*. Other graduations are placed by means of a protractor. In the figure, graduations are placed and marked 10° apart. Intermediate graduations may be added as desired.

In order to place range graduations on the rotating arm, a particular point is assumed where the angle *BAT* is 90°. Target azimuth 190° is such a point. In this case the general parallax formula in paragraph 29 takes the form

$$p = \sin^{-1} \frac{d}{\text{range}}$$

since $\sin \text{BAT}$ is unity. Using this formula the following table is prepared for use in the graduation of the rotating arm:

Range	d/range	p in degrees
3,000	0.0333	1.91
3,500	.0286	1.64
4,000	.0250	1.43
4,500	.0222	1.27
5,000	.0200	1.15
6,000	.0167	.96
7,000	.0143	.82
8,000	.0125	.72
9,000	.0111	.63
10,000	.0100	.57
15,000	.0067	.38
20,000	.0050	.29
25,000	.0040	.23

The rotating arm is constructed to solve azimuth difference when the line *AB* and the line *AT* are perpendicular to each other. For any other azimuth the rotating arm graphically multiplies by the sine of the angle between the line *AB* and the line *AT* and therefore solves completely the general parallax formula.

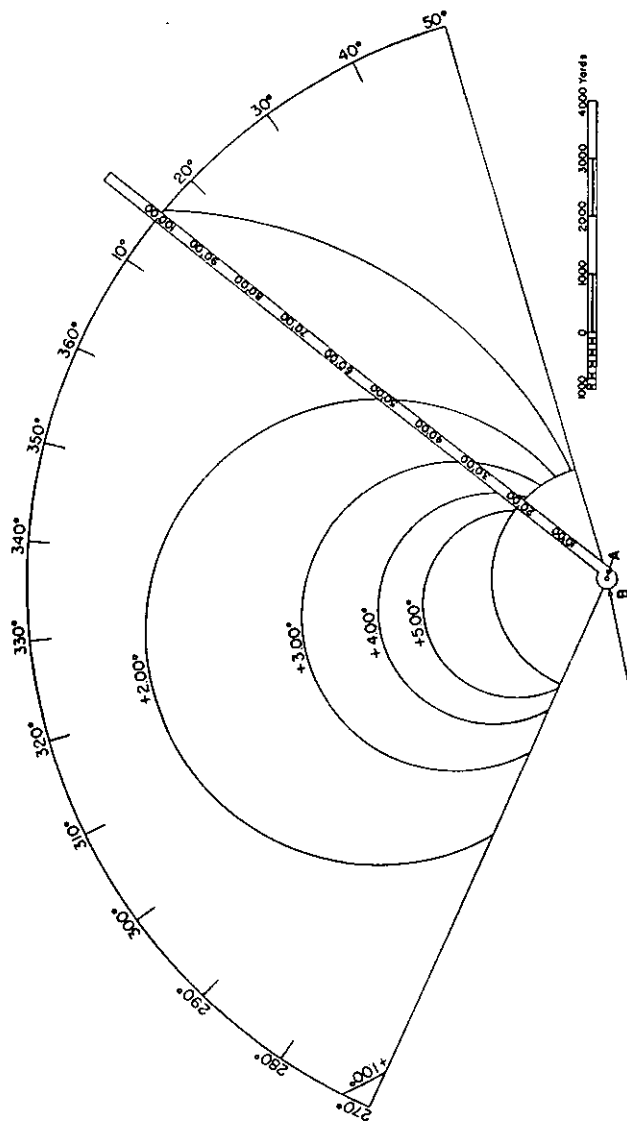

FIGURE 12.—Azimuth difference chart, type 2.

■ 31. AZIMUTH DIFFERENCE CHART, TYPE 2.—*a. Description.*—
 (1) This device (fig. 12) consists of a graphical representation of the field of fire on which are—

(a) A horizontal plot of the station *A* from which data are known and station *B* for which relocation is desired.

(b) An azimuth circle centered about station *A*.

(c) A series of azimuth difference circles whose centers are on the perpendicular bisector of the line *AB*.

(d) A range scale pivoted about station *A*.

(2) Figure 12 shows a typical solution. *A* is the observation station and *B* the directing point. The azimuth and length of the line *AB* are 235° and 280 yards, respectively. The field of fire extends from 270° to 50° with 340° at its center. The range limits are from 2,000 to 10,000 yards. In the figure, azimuth difference circles for 1° , 2° , 3° , 4° , and 5° of azimuth difference are shown. In practice, azimuth difference circles for smaller differences would be constructed, the smallest difference at the longer ranges being 0.025° .

b. Construction of azimuth difference circles.—Two propositions of geometry are used: first, the exterior angle of a triangle is equal to the sum of the two opposite interior angles; and second, an inscribed angle is measured by one-half the intercepted arc. In figure 13, let *A* represent the observation station and *B* the directing point. Join *A* and *B* by a straight line and prolong it to *D*. Construct the perpendicular bisector *MN* of the line *AB*. This line is called the line of centers. With any point on *MN*, as *C*, as a center and *CB* ($=CA$) as a

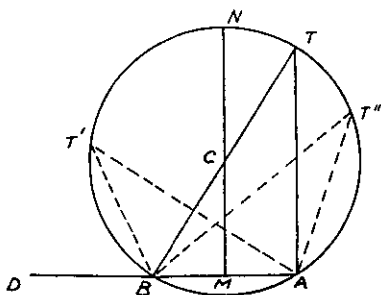

FIGURE 13.—Construction of azimuth difference circles.

radius, describe a circle. Construct the diameter through *C* and *B* and draw *TA*. Select any other points at random, as *T'* and *T''*, and join them to *A* and *B* by straight lines. Angle $TBD = BTA + TAB$; hence angle $BTA = TBD - TAB$; that is, the angle *BTA* is equal to the difference in azimuth between the lines *BT* and *AT*. The angles *AT'B*, *AT''B*, and *ATB* each intercept the same arc *AB* and are therefore equal; hence, for all points on the circle, the azimuth difference from *A* and *B* is the same, and is equal to the angle *ATB*. If any number of circles with varying radii be similarly drawn through *A* and *B*, each will be the locus of points of equal azimuth difference. The following formula is useful in constructing azimuth difference circles:

$$MC = BM \cot BCM = \frac{AB}{2} \cot BTA$$

Assuming successive values for angle *BTA* in this formula, the corresponding values of *MC* may be computed and tabulated. The data for the construction of the circles shown in figure 14 are as follows:

$$\frac{AB}{2} = 140 \text{ yards}$$

<i>BTA</i> (degrees)	Cot <i>BTA</i>	<i>MC</i> (yards)
1.00	57.29	8,021
2.00	28.64	4,010
3.00	19.08	2,671
4.00	14.30	2,002
5.00	11.43	1,600

c. *Construction of chart.*—Select the point *A*, lay off and label center line and outer limits of field of fire (for reference), and plot the point *B*. Construct the azimuth circle, with *A* as the center, at the outer range limit of the field of

fire, and graduate it. Compute and tabulate the values of MC for the values of the azimuth difference desired. Lay off the perpendicular bisector MN , construct the azimuth difference circles, and label them to read azimuth corrections. Construct and mount the range scale with pivot at A .

d. Operation of chart.—Set the range scale at the azimuth to the target, and at the range to the target read the azimuth correction. In figure 12 the range scale is set for an azimuth of 15° . The azimuth correction for a range of 5,000 yards is $+2^\circ$, making the azimuth of the target from the directing point equal to 17° .

SECTION III

RANGE DIFFERENCE

■ 32. FORMULA.—In figure 14 the range difference from the points A and B is calculated for point T . Angle BAT can be obtained from the known azimuths of AB and AT .

$$AX = d \cos BAT \quad (1)$$

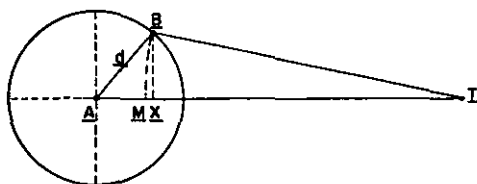

FIGURE 14.—Range difference.

Actually the range difference is AM which is obtained by swinging an arc from B with T as a center. For all practical purposes $AX = AM$ and equation (1) may be written

$$\text{Range difference} \approx d \cos BAT \quad (2)$$

It can be seen from the formula that range difference is not considered to be affected by changes in range but only by changes in azimuth to the target.

■ 33. RANGE DIFFERENCE CHART—*a. General.*—A range difference chart (fig. 15) is actually a graphical arrangement of the solution by formula. The chart consists of an azimuth

circle with an auxiliary scale showing the range difference opposite the corresponding azimuth.

b. Example.—Construct a chart of range differences from a point *B* to *T* when the range and azimuth from *A* to *T* are known. The azimuth from *A* to *B* is 60° and the displacement is 100 yards. Show the values of range difference to the nearest 10 yards—that is, a maximum range difference of 100 yards will be used until the actual difference becomes smaller than 95 yards, when a value of 90 yards will be used until the actual value becomes less than 85 yards, when 80 yards will be used, and so on. In order to locate the points where a change takes place, a table is constructed from the formula in equation (2) (par. 32) rewritten as follows:

$$\cos BAT = \frac{\text{Range difference}}{d}$$

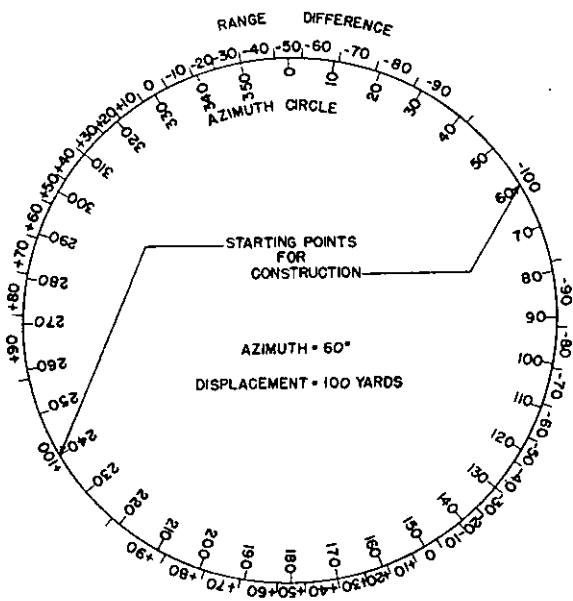

FIGURE 15.—Range difference chart.

1	2	3
Range difference (yards)	Cos <i>BAT</i>	Angle <i>BAT</i> (degrees)
100	1.00	0
95	.95	18
85	.85	32
75	.75	41
65	.65	49
55	.55	57
45	.45	63
35	.35	70
25	.25	76
15	.15	81
5	.05	87
0	.00	90

The angles shown in column 3 are taken to the nearest degree. The values of the angles apply to each quadrant. The range differences, however, are positive for two quadrants and negative for the other two. The foundation of the chart is the azimuth circle of figure 14. The example gives the displacement as 100 yards and the azimuth from *A* to *B* as 60° . The maximum range differences are then at target azimuths of 60° and of 240° . The former range difference is -100 yards and the latter is $+100$ yards. According to the table, 100 yards is the range difference until the target azimuth changes 18° on either side of the 60° and 240° graduations. Marks are, therefore, drawn at 60 ± 18 and 240 ± 18 or at target azimuths of 78, 42, 258, and 222. The next marks are at 60 ± 32 and 240 ± 32 or at 92, 28, 272, and 208 for a difference of 90 yards. Other marks are located in a similar manner. Zero range differences are at target azimuths 150 and 330.

SECTION IV

ELEVATION DIFFERENCE

■ 34. GENERAL.—The solution of elevation difference requires the use of firing tables or of a chart based on the firing

tables. The general formula for range difference (see par. 32 and fig. 14) is—

$$\text{Range difference} = d \cos BAT$$

If d in the equation is changed into elevation at the range under consideration, the resulting equation produces the elevation difference for that particular range. While range difference for all practical purposes is affected by changes in azimuth only, elevation difference is, in general, affected both by changes in range and by changes in azimuth.

■ 35. ELEVATION DIFFERENCE CHART.—*a. General.*—The elevation difference chart, figure 16, consists of an azimuth circle with a rotating arm, graduated in range, pivoted at the center of the circle. To operate the device, the arm is turned to the azimuth of the target, and the elevation difference is read on that vertical line which is opposite the range.

b. Example.—Construct a chart of elevation differences in mils for a 16-inch gun, M1919, using 2,100-pound A. P. projectile and full charge (Firing Tables 16-B-1), low angle fire only, up to a range of 44,300 yards.

NOTE.—Above 44,300 yards the range is approaching the maximum. At this point the change in elevation corresponding to a change of 100 yards in range is very large and is not shown accurately in the firing tables.

The azimuth from the directing point to the offset gun is 60° , and its displacement is 100 yards. The field of fire of this gun is from 240° through 360° to 70° azimuth.

An azimuth circle of any convenient radius is constructed first, placing 60° , the azimuth to the offset gun, opposite the horizontal radius (fig. 16). Next, the vertical lines are drawn. They are equally spaced and must be sufficient in number to accommodate the maximum elevation difference. The maximum elevation difference (the maximum shown in the firing tables) in this case will be for a gun difference of 100 yards at 44,300 yards' range which Firing Tables 16-B-1 show to be 8.9 mils. By visualizing this example and referring to paragraph 32 (including fig. 14) and to paragraph 33 (including the table), it can be seen that all values of elevation difference to the right of the pivot are negative and those to the left are positive.

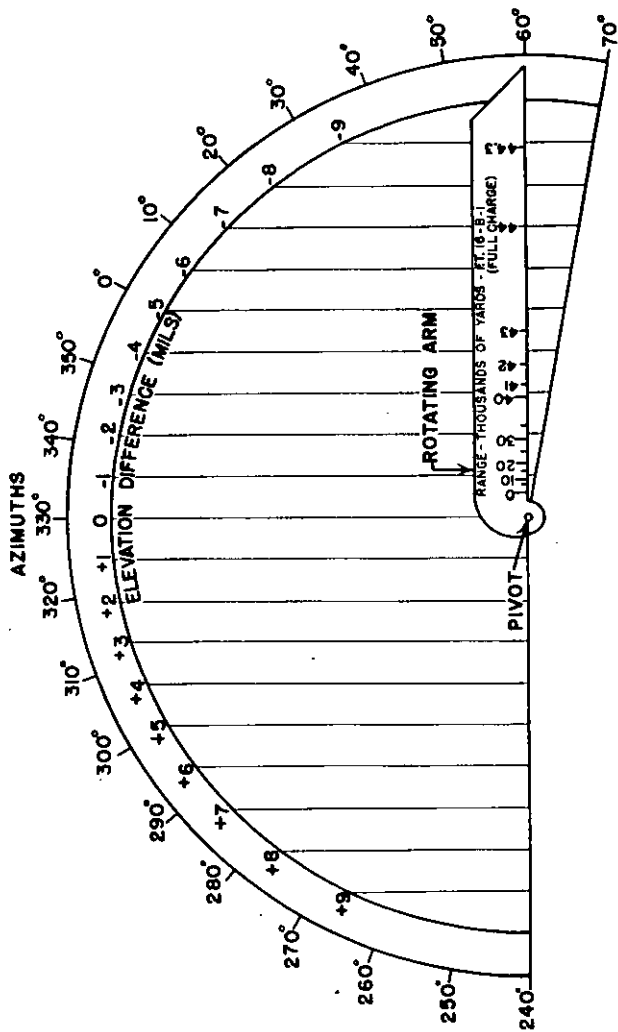

FIGURE 16.—Elevation difference chart.

The rotating arm is graduated in range to produce the proper elevation difference where the gun difference is a maximum (that is, where it is equal to the displacement which is 100 yards), in this case at target azimuth 60°. The following table shows the data extracted from Firing Tables 16-B-1 for use in graduating the rotating arm. It shows in column 2 the elevation difference corresponding to a range change of 100 yards at each of the ranges shown in column 1.

1	2
Range (yards)	Change in elevation (mils) for 100 yards' change in range
0	0.6
5,000	.8
10,000	.9
15,000	1.1
20,000	1.3
25,000	1.6
30,000	1.9
35,000	2.2
40,000	2.9
41,000	3.2
42,000	3.7
43,000	4.5
44,000	7.0
44,300	8.9

To locate the graduations on the rotating arm, the arm is set at azimuth 60°. The graduations are placed on the arm by reference to the table and interpolation between the points where the vertical lines of the chart intersect the reading edge of the arm. For example, the zero range graduation is placed on the arm at a point six-tenths of the distance from the zero vertical line to the 1-mil vertical line; and the 30,000-yard range graduation is placed at nine-tenths of the distance from the 1-mil vertical line to the 2-mil vertical line. Since the general formula for range difference is

$$\text{Range difference} = d \cos BAT$$

it follows that with the rotating arm graduated to solve the elevation difference for the distance d , rotation of the arm to another azimuth will multiply graphically by $\cos BAT$ (see fig. 14), thereby giving a general solution for elevation difference.

NOTE.—If more than one kind of ammunition (including sub-caliber) is to be used, the vertical lines should be sufficient in number to accommodate the ammunition with the greatest elevation difference so that when ammunition is changed it will be necessary to change only the rotating arm on the chart.

SECTION V

GUN DISPLACEMENT

■ 36. CORRECTIONS TO DIRECTION.—*a. Deflection.*—When guns are pointed by means of deflection (cases I and II), each gun sight with proper deflection setting applied is directed at the target. (See par. 21.) Therefore, no correction for displacement is made to the deflection.

b. Azimuth.—It is desirable to point each gun in direction with a maximum accuracy error of 0.03° . If the guns are close to the directing point it may be possible to obtain the required accuracy for all service ranges by pointing the guns parallel to each other without correction. Where the field of fire is narrow, sufficient accuracy may be obtained by causing the guns to converge at a central point in the field of fire when all are set with the azimuth from the directing point to that central point. In a fixed mortar battery, a common method is to adjust the two guns of a pit to fire parallel to each other and to converge the two pits on a central point. The methods of adjusting guns to converge or to be fired parallel to each other are discussed in chapter 17.

When parallax is so large that a mean correction will not suffice, the usual method is to make the parallax correction in the plotting room and send separate azimuths to the individual guns. The M1 deflection board is equipped with a displacement corrector so that azimuths may be furnished for two separate points. There is also a scale on this instrument where the value of the parallax can be read.

With either the plotting and relocating board M1 or the Cloke plotting and relocating board, separate azimuths may be read for each gun of the battery by use of the gun plate and the method of offset plotting. (See par. 77.)

In the absence of instruments of the required type, an azimuth difference chart of some form must be used to make parallax corrections. The transmitter of the data transmission system M5 (par. 186) has means of applying parallax corrections.

■ 37. CORRECTIONS TO RANGE (OR ELEVATION).—*a. General.*—

When the displacement is small the gun difference is negligible. The fixed mortar battery furnishes a good example of small displacement. This type of battery has two pits of two mortars each with about 30 yards between pits. In this case the range (or elevation) usually is determined for the directing point of the battery, midway between pits, and no corrections are made for gun differences. Due to the terrain, the size of the guns, or for protection, the guns of a battery are sometimes widely separated, and corrections must be made for gun differences. Such corrections are determined by methods discussed in paragraphs 32 and 33. They usually are applied to the firing data in one of the ways described in *b* below.

b. (1) Ranges in yards.—When ranges are set in yards by means of range disks, the corrections may be made either in the plotting room or at the guns. If the plotting board is of a type permitting relocation for individual guns (par. 77), the range is furnished for each individual gun. If the plotting board is of any other type, the gun differences may be determined by use of a range difference chart (par. 33) and the range furnished for each individual gun. When corrections are made at the guns, an arrow is painted on the edge of the rotating platform so that it can be seen from the elevating handwheel. This arrow is used as an index to a scale painted on the emplacement, touching and concentric with the gun platform. The scale is a range difference chart (fig. 15). The correction indicated on the scale by the arrow, when the gun is pointed in azimuth, is applied to the range before it is set on the range disk.

(2) *Ranges in terms of angular units.*—When ranges are set in terms of angular units, as quadrant elevations, the corrections are determined by means of an elevation difference chart (fig. 16) in the plotting room, and the elevation is sent to each gun. The transmitter of the data trans-corrections are determined by means of an elevation differences in mils. (See par. 186.)

CHAPTER 6

TIMING OF POSITION FINDING SYSTEM

■ 38. GENERAL.—*a.* Since the calculation of firing data is not continuous, some coordination is necessary between the operation of calculating the firing data and that of loading and firing the guns. Arrangements must be made either to provide the firing data for the instant the gun is to be fired or to fire the guns at the instant for which the data have been calculated. The operations necessary in the process of preparation of firing data and the firing of the guns using those data are—

- (1) Observation on the target and transmission of the observed data to the plotting room;
- (2) Plotting of the observed position of the target;
- (3) Location of the set-forward point;
- (4) Relocation;
- (5) Calculation of corrected firing data;
- (6) Transmission of those data to the guns;
- (7) Restoration of the guns to the loading position (after firing of the preceding round);
- (8) Loading of the guns;
- (9) Pointing of the guns; and
- (10) Firing of the guns.

b. Some of these operations (*a* above) take place concurrently, whereas some cannot be performed until certain others have been completed. Operations (1) to (6), inclusive, are performed in order, followed immediately by operations (9) and (10) in order. Operations (7) and (8) need not await completion of (1) to (6) but may take place concurrently with (1) to (6). (They may, however, require either more or less time than that required for operations (1) to (6), inclusive.) Furthermore, upon completion of operation (4) for a particular set of firing data, operation (1) of the series for the next set of firing data may be performed, followed in order by the others as before. In the determination of the lengths of the observing interval, the

dead time, and the firing interval, and of the best method of coordinating them, the principles of simplicity, speed, and accuracy must again be applied.

■ 39. TIME INTERVALS.—*a.* The observing interval must be long enough to provide time for operations (1) to (4), inclusive (par. 38*a*). On the other hand, it must be short enough to provide firing data with the desired frequency. There must be kept constantly in mind the necessity for avoiding excessively long observing (and predicting) intervals. The longer these intervals, the greater becomes the total elapsed time during which a target may change course or speed (or both) without proper corrections for these changes being incorporated in the firing data. With the higher speeds of modern ships and the greater times of flight corresponding to longer ranges, the necessity for keeping the observing and predicting intervals at a minimum assumes added importance. An observing interval of 15 to 20 seconds with the shortest practicable predicting interval will usually fulfill all conditions satisfactorily.

b. The dead time must be long enough to provide time for performance of operations (1) to (6), inclusive, and (9) and (10). Usually the system selected is such that the time required for operations (5), (6), (9), and (10) is not greater than that required for operations (1) to (4) inclusive, and the dead time will be not greater than twice the observing interval. The length of the dead time is dependent on the combination of observing and firing intervals selected. When more than one combination of observing and firing intervals is possible, the one selected should be the one which gives the shortest dead time.

c. The firing interval must be long enough to provide time for operations (7), (8), and (9). Since we must provide for operation over long periods, the minimum length of the firing interval is determined by the maximum sustained rate of fire. Its maximum length is limited only by the tactical situation but is usually some multiple of the minimum length. Therefore, if firing data are furnished with sufficient frequency for the minimum firing interval, all normal situations are provided for. Normal rates of fire for target practice for each type of armament are prescribed for each calendar

year in the annual training memorandum, "Instructions for Coast Artillery Target Practice," issued by the War Department. These rates may be considered as the maximum sustained rates attainable with the types of armament for which prescribed.

■ 40. COORDINATION OF TIMING.—The simplest combination of observing and firing intervals is the one in which they are of equal length. This is standard practice for 6-inch and 155-mm gun batteries. Larger caliber batteries have longer firing intervals. For those larger caliber batteries, the observing interval is made such that it is contained into the firing interval a whole number of times, and firing does not take place on every set of firing data furnished. However, furnishing firing data once each observing interval allows the battery or one or more guns of the battery to fire without waiting a whole firing interval, if for any reason it had been impossible to fire on a particular set of data. For 3-inch rapid fire batteries the observing interval is greater than the firing interval and data are furnished as frequently as possible. (See par. 10.) In this case the delay in firing is of no consequence.

NOTE.—In order to provide accurate firing data under service conditions the observing interval must be not greater than 20 seconds in any case.

CHAPTER 7

OBSERVATION INSTRUMENTS

	Paragraphs
SECTION I. General	41
II. Azimuth instruments	42-43
III. Depression position finders	44-47
IV. Self-contained base instruments	48-51

SECTION I

GENERAL

■ 41. CLASSIFICATION.—Observation instruments used in position finding are classed as azimuth instruments, depression position finders, and self-contained range finders.

a. An azimuth instrument is an instrument used for the purpose of measuring horizontal angles (usually azimuths). Some models are equipped also for measuring small vertical angles. Instruments of this class are for use with the horizontal base system. They are used also with the self-contained base system. (See sec. IV.)

b. A depression position finder (D. P. F.) is an instrument used for measuring ranges by the depression angle method and for measuring horizontal angles (usually azimuths). Instruments of this class are for use primarily with the vertical base system. They may be used also with the horizontal base system in lieu of an azimuth instrument.

c. A self-contained range finder is an instrument used for measuring ranges by direct observation. There are two types of instrument, the coincidence type and the stereoscopic type. Later models are equipped for measuring azimuths. The self-contained range finder is furnished for use with rapid-fire batteries.

SECTION II

AZIMUTH INSTRUMENTS

■ 42. AZIMUTH INSTRUMENT, M1910A1 (fig. 17).—a. *Description.*—This instrument is furnished for use with all seacoast artillery, except 155-mm, for the measurement of horizontal angles. It is not equipped to measure vertical angles.

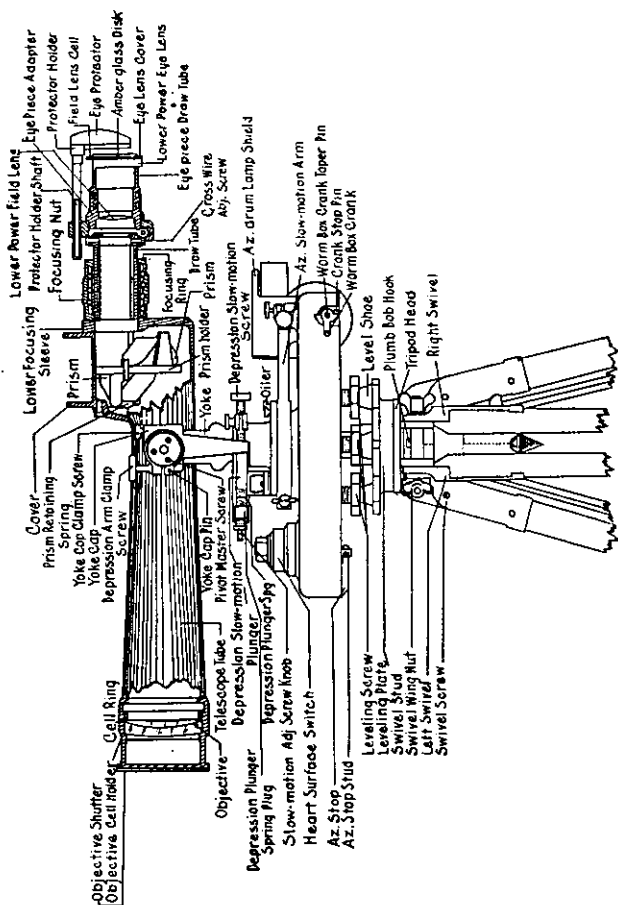

FIGURE 17.—Azimuth instrument, M1910A1.

(1) The telescope contains an optical system consisting of an objective lens, erecting prisms, and eyepiece. Two eyepieces are furnished, one giving 10-power and one giving 15-power magnification. A reticle is inserted in the system ahead of the eyepiece with provisions for moving the reticle into the plane in which the image is cast. The reticle consists of a piece of glass on which are etched a vertical line which serves as the vertical cross wire and a deflection scale which is in position as the horizontal cross wire. The scale is graduated in degrees from right to left with a least graduation of 0.02° and with 3° as the normal (or zero deviation). (See pars. 52 and 53.) The deflection scale is for use when the instrument is employed for spotting. (See ch. 13.) It is provided with a movable pointer called a "splash pointer." If the cross wires intersect the target at the instant of splash and if the pointer is moved independently to the center of the splash, the scale indicates in reference numbers the angular deviation, as viewed from that station. Older models of this instrument, designated as M1910, have the deflection scale on a transparent piece of celluloid in the lower part of the field. The scale has a least graduation of 0.05° .

(2) The base provides means of holding the telescope, of imparting to it motion in vertical and horizontal planes, and of measuring the horizontal movement. The principal parts of it are the yoke, the traversing mechanism, the azimuth circle and index disk subscale, and the leveling mechanism. The telescope is suspended in bearings in the yoke, allowing about 40° of movement in a vertical plane. The instrument is traversed in slow motion by operating the azimuth drum crank, which turns the azimuth drum and yoke, through a worm gear. The worm may be disengaged to allow fast traversing by hand and reengaged without disturbing the orientation of the instrument. The azimuth circle is graduated in degrees; the index disk subscale is graduated in hundredths of a degree. Provision is made for traversing the telescope and yoke independently of the azimuth drum and circle for use in orienting. The leveling mechanism consists of a leveling plate, four leveling screws, and two levels.

(3) The tripod consists of a tripod head and three adjustable legs. The base screws onto the tripod head. Pier mounts consisting of tripod heads on concrete or steel supports are usually provided for use in permanent base end stations for fixed seacoast artillery.

b. Adjustment and orientation.—The adjustments of the instrument consist of the exact location of the instrument over the point representing the base end station, the leveling of the instrument, the focusing of the eyepiece, and the focusing of the objective and removal of parallax. The orientation of the instrument consists of making it read the correct azimuth of a point when sighted on that point. The complete operation of setting up, adjusting, and orienting is as follows:

(1) *Approximate location.*—Set up and adjust the height of the tripod, mount the base on the tripod head, and suspend the plumb bob from the base. With the aid of the plumb bob, place the tripod and base approximately over the point representing the base end station, making the tripod head approximately level. Mount and secure the telescope in place on the yoke.

(2) *Approximate orientation.*—Set the azimuth index and subscale to read the azimuth of a known datum point visible from the station. Loosen the azimuth clamp screw and turn the telescope so that the eyepiece is slightly to the left of the reading window and the azimuth drum crank handle. Lift up the instrument and tripod together and set them down so that the telescope points approximately at the datum point.

(3) *Exact location.*—Center the plumb bob over the point representing the station by shifting the tripod legs, keeping the tripod head approximately level and the telescope pointed approximately at the datum point. When using the pier mount, the operation of locating the instrument is done by mounting it on the place provided.

(4) *Leveling.*—See that all four leveling screws have a uniform and moderately firm bearing on the leveling plate. Release the traversing worm by rotating the worm box crank, and traverse the instrument until one of the levels is parallel to two diagonally opposite leveling screws; turn those screws.

one clockwise and the other counterclockwise, until the bubble of that level is centered. The bubble will follow the direction of motion of the left thumb. Without traversing the instrument, center the bubble of the other level by means of the two remaining leveling screws, readjusting each bubble for any error caused by centering the other. (*Caution:* In turning the leveling screws maintain the uniformly moderate bearing of all screws on the plate; if the screws bind, loosen one screw and proceed with the operation. Binding of the screws will bend the spindle and make correct leveling of the instrument impossible in the future.) Traverse the instrument through 180° and check the level; if a bubble departs from the center, correct one half of the variation by the adjusting screws on the level box and the other half by the appropriate pair of leveling screws. Repeat the complete operation until the level bubbles remain centered for any position of the telescope in azimuth.

(5) *Focusing eyepiece.*—This operation consists of screwing the eyepiece in or out so as to bring out most distinctly the roughness of the cross wires. It should be done with the telescope pointed toward the sky. This adjustment will be constant for a given observer.

(6) *Focusing objective and removal of parallax.*—Direct the telescope at the datum point and move the objective lens in or out, by means of the focusing ring, until there is no parallax of the cross wires, that is, no apparent movement of the cross wires across the image of the datum point as the eye is moved across the eyepiece. The cause of parallax is the lack of coincidence between the focal plane of the objective lens and the plane of the reticle. It is often impossible to remove parallax completely from both the vertical and the horizontal cross wires. In azimuth instruments, the complete parallax adjustment should be made for the vertical cross wire. This adjustment will be constant for a given instrument. If used by another observer, he should adjust the instrument for clearness of vision by focusing the eyepiece not the objective.

(7) *Exact orientation.*—After all adjustments have been made, reset the instrument to the azimuth of the datum point, loosen the azimuth clamp screw, and bring the verti-

cal cross wire of the telescope approximately on the datum point. Tighten the azimuth clamp screw and, using the azimuth slow motion screw, bring the vertical cross wire exactly on the datum point. Clamp the azimuth slow motion screw. Check all adjustments and reorient if necessary. The orientation should be checked on at least one other known datum point if possible.

c. Operation.—The instrument is operated by two men, an observer and a reader. The observer receives, by telephone, the command assigning the target. He directs the vertical cross wire of his instrument on the target and reports "On target." At the command TRACK he tracks the target, keeping the vertical cross wire on the designated observing point by turning the azimuth drum crank. At the intervals indicated by the TI bell he stops tracking momentarily to permit the reader to transmit the azimuth to the plotting room.

■ 43. AZIMUTH INSTRUMENT, M1918.—*a.* At present this instrument is furnished for use with 155-mm guns. (See note, par. 12.) It is similar to the M1910A1 instrument. The main differences are—

- (1) The telescope is smaller and lighter.
- (2) Two eyepieces are furnished, one of 10-power and one of 20-power.
- (3) The instrument is equipped to measure vertical angles from -300 to $+500$ mils.
- (4) The azimuth circle and index disk subscale and the interior splash scale are graduated in mils.

b. The adjustment, orientation, and operation are the same as for the M1910 instrument except that there is no provision for eliminating parallax, since the telescope is of the fixed focus type.

SECTION III

DEPRESSION POSITION FINDERS

■ 44. RANGE FINDING BY DEPRESSION ANGLE METHOD.—*a.* The method of range finding by means of the depression angle is used by depression position finders employed in the vertical base position finding system. By this method the range to the target is determined by measuring the angle at the

instrument between the horizontal and the line from the instrument to the water line of the target, and by indicating on a graduated scale the product of the cotangent of that angle by the height of the instrument above the target. In this method the effect of the curvature of the earth must be

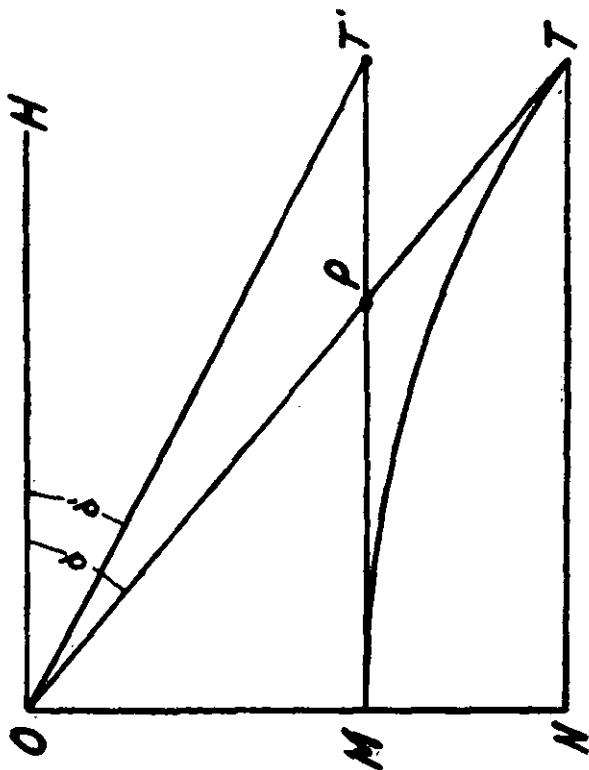

FIGURE 18.—Effect of curvature of earth on line of sight.

considered. The problem is illustrated in figure 18, where O represents the position of the observer at a height OM above sea level, the arc MT represents the surface of the sea, and T the position of the target on the sea. By sighting on the target the angle d is measured. This angle com-

bined with the true height OM will give a range MP , whereas the desired range is $NT (=MT')$. This range could be computed by using a corrected depression angle d' or by using a corrected height of instrument ON . The latter method is used in seacoast artillery instruments. The instruments are

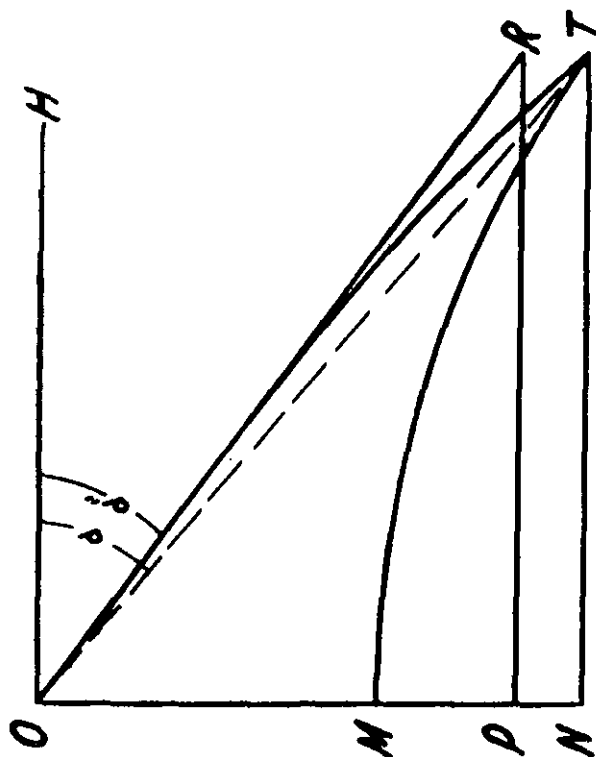

FIGURE 19.—Effect of atmospheric refraction on line of sight.

designed to correct without appreciable error for all values of the depression angle.

b. The problem is further complicated by atmospheric refraction. As the rays of light pass from the target to the observer they are bent downward so that the apparent change in the height of instrument due to curvature of the earth is

less than the true change. The effect of refraction is illustrated in figure 19 which is similar to figure 18. Because of refraction, a ray of light from the target will reach the observer by the curved path TO and the target will appear to be on the line OR . As in the case of curvature alone, the desired range is the range NT but the proper height of instrument is the height OP . The amount of refraction is extremely variable, and the variations from normal can be detected only by checking the instrument on a datum point of known range.

c. Corrections for curvature of the earth and for normal refraction are made on the instruments by graduating the range disks for the corrected height of instrument (OP , fig. 19). Provision is made on all instruments to compensate automatically for changes in the effect of curvature and normal refraction due to changes in the depression angle. Small changes in the height of instrument due to tide and changes in refraction from normal may be corrected for without appreciable error. Those adjustments are discussed in detail in the paragraphs dealing with the separate instruments.

■ 45. SWASEY DEPRESSION POSITION FINDER (fig. 20).—*a. Description.*—The Swasey D. P. F. is an instrument equipped to measure horizontal angles and to measure ranges by the depression angle. It may, therefore, be used in either a horizontal or a vertical base system. It is an older type instrument. (See par. 46.)

(1) The telescope contains an optical system similar to that of the azimuth instrument but with a larger field and more illumination. Eyepieces are furnished for 12- and 20-power magnifications. A vertical wire and a horizontal wire are carried in a slide in the micrometer box allowing vertical motion of the slide. The instrument does not have an interior splash scale.

(2) The cradle provides means of supporting the telescope, of imparting to it motion in vertical and horizontal planes, and of making the necessary adjustments to permit reading correct azimuths and ranges. The traversing mechanism is similar to that of an azimuth instrument. The azimuth scale is graduated in degrees; the azimuth drum (subscale) is graduated in hundredths of a degree. The range drum is

graduated to indicate every 10 yards of range between 1,500 and 12,000 yards. The leveling mechanism is similar to that of an azimuth instrument.

(3) The base is a heavy metal casting which supports the cradle and telescope.

b. Adjustment and orientation.—The adjustments of the instrument are the leveling, the focusing of the eyepiece, the focusing of the objective and removal of parallax, the check of the range drum for telescope level, and the range ad-

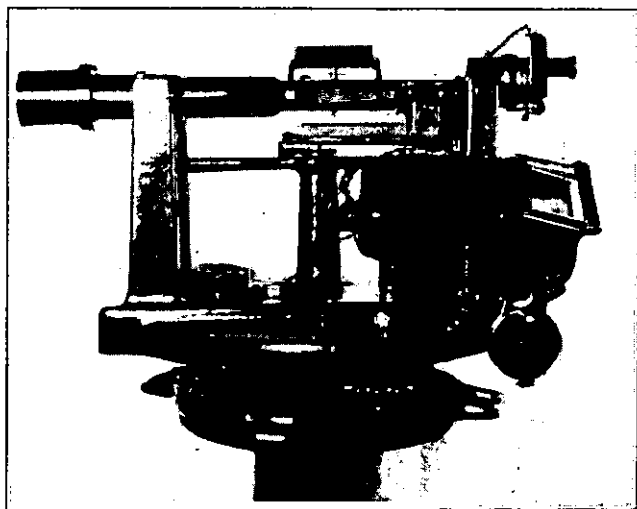

FIGURE 20.—Swasey depression position finder.

justment (for curvature of the earth, refraction, and tide). The orientation of the instrument consists of making it read the correct azimuth of a point when sighted on that point. Small adjustments in azimuth may be made by means of the azimuth set screws. The complete operation is generally similar to that outlined in paragraph 42 for the azimuth instrument, M1910A1, except that the parallax adjustment must be made for both the horizontal and the vertical cross

wires. The additional adjustments not discussed in that paragraph are as follows:

(1) *Telescope level.*—After the instrument is leveled, the range crank should be rotated until the level on the top of the telescope indicates that the telescope is horizontal. The range drum reading should then be "telescope level." If it is not, loosen the screws attaching the range drum to the bevel gear and, holding the telescope horizontal, rotate the range drum until it reads "telescope level." Tighten the holding screws. The bubble of the level should then remain stationary while the height slide is moved to any position.

(2) *Range adjustment.*—After the check for telescope level, the range adjustment may be made. As the first step, set the height slide so that the reading on the height scale is that of the instrument corrected for the tide (if known). Select two datum points, D_L at a range somewhat longer, and D_S at a range somewhat shorter, than the ranges over which it is expected to work. Using the range crank, set the range drum at the reading of D_L and direct the telescope at that point in direction; bring the horizontal cross wire to the water line of that point by means of the micrometer screw. Using the range crank, set the range drum at the reading of D_S and direct the telescope at this point in direction; bring the horizontal cross wire halfway to the water line of this point by means of the height slide pinion. Repeat these two operations until correct readings on both D_L and D_S can be obtained by operating only the azimuth drum handle and the range crank. This adjustment should be repeated at intervals, the frequency depending on the extent of the variation in tide and refraction.

c. Operation.—The instrument is operated by two men, an observer and a reader. For the vertical base system, the observer tracks the target, keeping the vertical cross wire on the designated observing point by turning the azimuth drum handle, and the horizontal cross wire on the waterline of the target by turning the range crank. At the intervals indicated by the TI bell, he stops tracking momentarily to permit the reader to transmit, first, the azimuth and, second, the range, to the plotting room. For the horizontal base system the target is tracked in azimuth only.

■ 46. DEPRESSION POSITION FINDER, M1907 (fig. 21).—*a. Description.*—The D. P. F., M1907, is a later type of instrument than the Swasey instrument. Each Swasey D. P. F. is made for a particular height and is not suitable for use at different heights. The M1907 type is issued in fifteen classes, each class being specially designed for use at a different range of heights (except that classes DM and DMM have the same range of heights; see table) with the classes overlapping so

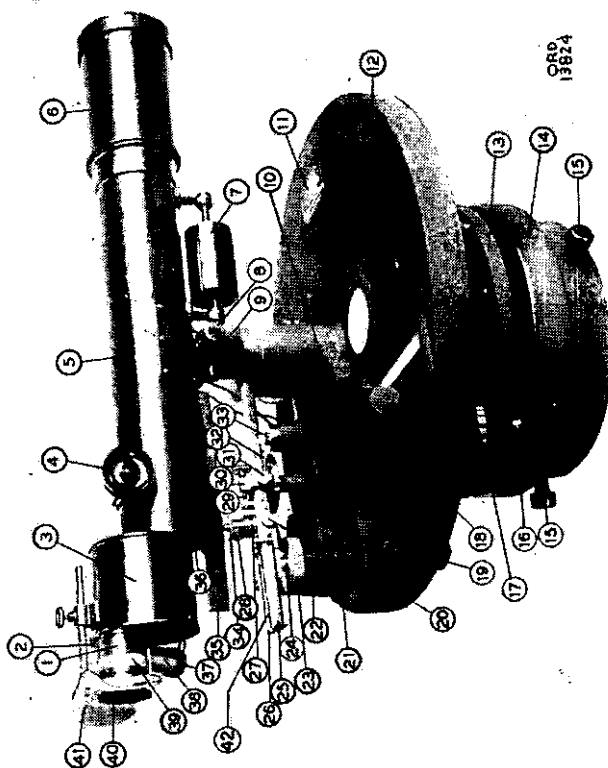

FIGURE 21.—Depression position finder, M1907.

as to cover all heights from 25 to 1,140 feet. In this way, a much greater degree of accuracy is obtained than is possible with the older type. The instruments have interchangeable depression mechanisms, height scales, and range dials, making it possible and convenient to convert an instrument from one class to another.

D. P. F., M1907

Class	Heights for which designed (feet)	Limits of graduation on range drum (yards)— minimum, maximum
A	35-80	1,500-12,000
B	60-145	1,500-12,000
BM	60-145	1,500-15,000
C	125-300	1,500-12,000
CM	125-300	1,500-20,000
D	280-600	1,500-12,000
DM	280-800	1,500-20,000
DMIM*	280-800	1,500-20,000
DM1	380-1,140	2,000-20,000
DM1M1	380-1,025	2,000-20,000
AA	25-60	1,000-6,000
DD	160-400	1,000-6,000
EE	300-750	1,000-6,000
E	90-210	600-9,000
F	165-400	600-9,000

* Differs from DM in minor structural details.

(1) *Telescope*.—The optical system is similar to those previously described. Eyepieces are provided for 15- and 25-power magnifications. A counterweight (7) is furnished for adjusting the balance of the telescope.

(2) *Table assembly*.—The table and body serve the same purpose as the cradle of the Swasey D. P. F. Their mechanical features are, however, somewhat different. The method of indicating azimuths is unique. Two dials and a stationary scale are furnished: the azimuth dial, concentric with the vertical axis of the instrument, on which are read the hundreds and tens of degrees; the planetary dial, geared to rotate once for each 10 degrees, on which are read the unit place of degrees; and the stationary scale (or vernier) next to the planetary dial, on which are read the hundredths of a degree. The number to be read on the azimuth dial is the one in coincidence with or above the index; the unit place of degrees to be read on the planetary dial is the one that registers with some portion of the stationary scale. The hundredths of a degree are read from the stationary scale where the unit degree mark of the planetary dial registers on the scale. The method of indicating azimuths is illustrated in figure 22. The azimuth indicated in the figure is 79.75° . The range is indicated on a dial instead of a drum. The minimum and maximum ranges indicated depend upon the class of the instrument. The leveling mechanism has only three leveling screws of which any two may be used together to level in one direction. The third screw should then be used with each of the others to level in the other direction, taking up one-half of the adjustment with each pair.

(3) *Base*.—The base or pedestal is similar to the one previously described for the Swasey D. P. F.

b. *Adjustment and orientation*.—(1) *General*.—The adjustments of this instrument are the same as those listed in paragraph 45b for the Swasey D. P. F., except that no check of the range drum for telescope level is necessary and the range adjustment (see (2) below) is different. In the orientation of the instrument, the adjustment in azimuth is made by clamping the table to the body of the instrument and turning the pedestal cap until the vertical cross wire is on the

datum point. The level of the instrument should then be rechecked. One or two trials may be necessary before the vertical cross wire will remain on the datum point when the instrument is leveled.

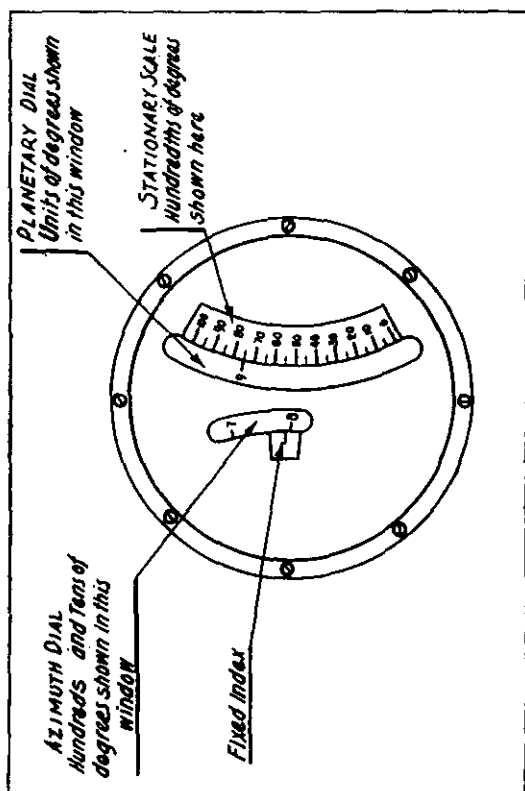

FIGURE 22.—Azimuth indication on depression position finder, M1907.

(2) *Range adjustment.*—(a) Having ascertained the condition of the tide at the moment, set the slide block (27) along the tangent screw rail (25) to that point on the height scale (42) which corresponds with the present height of the

instrument in feet and clamp the slide block by means of the clamping screw.

(b) Select two datum points, D_L at a range somewhat longer, and D_s at a range somewhat shorter, than the ranges over which it is expected to work.

(c) Point the telescope in direction at D_L and turn the outer sleeve nut (23), which operates the depression mechanism, until the range pointer indicates the range of D_L . If the horizontal cross wire of the telescope is not on the waterline of the datum point bring it on by means of the compensating screw (34), and clamp the compensating screw to the shaft of the rack gear by tightening the set screw (28).

(d) Point the telescope in direction at D_s and turn the outer sleeve nut (23) until the range pointer indicates the range of this datum point; bring the horizontal cross wire in halfway to the waterline of this point by moving the slide block by means of the slide block adjusting screw (29). The nut block (30) must be held fixed while making the adjustment.

(e) Repeat these two operations until correct readings on both D_L and D_s can be obtained by operating over the azimuth hand wheel and the outer sleeve nut.

(f) This adjustment should be repeated at intervals, the frequency depending on the extent of the variation in tide and refraction.

c. Operation.—(1) *General.*—The instrument is operated as described in paragraph 45c for the Swasey D. P. F. The target is tracked in azimuth by means of the pinion shaft head on the table at the left of the telescope and in range by means of the outer sleeve nut (23).

(2) *Precautions.*—(a) The depression mechanism should not be operated until the height setting has been made.

(b) The instrument should not be forced against the stops provided for minimum and maximum depression.

(c) The sun shade (6) should be kept in place at all times to preserve the proper balance of the instrument.

(d) When the 15-power eyepiece is used, the counterweight (7) should be screwed all the way out; when the 25-power eyepiece is used, it should be moved in slightly.

(e) The operator when tracking should be careful not to disturb the balance by resting his head against the eye shield.

■ 47. DEPRESSION POSITION FINDER M1 (fig. 23).—*a. Description.*—The D. P. F. M1 is the standard instrument now issued for use with seacoast artillery. It is similar to the M1907 D. P. F. It is issued in ten classes covering all heights of instrument from 74 to 1,395 feet. The eyepiece of this instrument may be set for any desired power from 10 to 30. Amber and blue ray filters are provided for use when desired. The method of indicating azimuths is by an azimuth circle giving degrees and a micrometer subscale indicating hundredths of a degree. The range is indicated by a pointer moving across a moving scale. The minimum and maximum ranges indicated depend upon the class of the instrument.

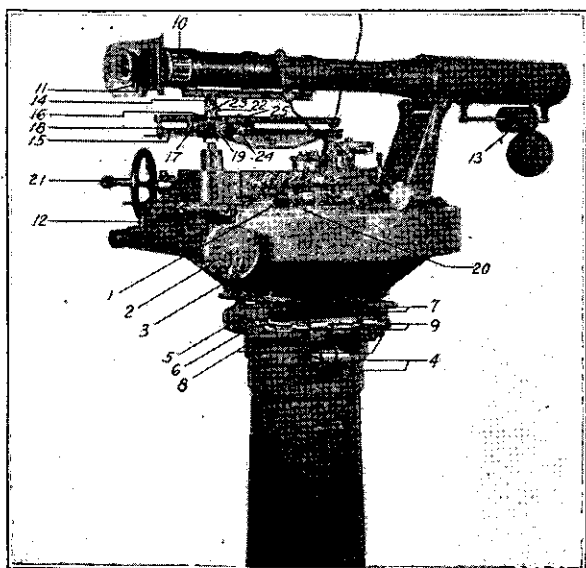

FIGURE 23.—Depression position finder M1.

D. P. F. M1

Class	Heights for which designed (feet)	Limits of graduation on range drum (yards)— minimum, maximum
1	74-135	1,500-20,000
2	100-182	2,000-24,000
3	150-272	2,500-30,000
4	260-475	2,500-38,000
5	350-650	2,500-45,000
6	450-810	5,000-50,000
7	575-1,045	5,000-55,000
8	750-1,395	3,000-56,000
9	750-1,375	5,000-60,000
10	625-1,160	2,500-45,000

¹ Class 8 is not fitted for use over 54,000 yards at heights below 1,000 feet.

b. Adjustment and orientation.—The adjustments of this instrument are the same as for the M1907 D. P. F. (par. 46b). In the orientation of the instrument, the coarse adjustment in azimuth is made by loosening the three cap screws (8) and rotating the leveling plate (5); the fine adjustment is made by means of the adjusting screws (9).

c. Operation.—The instrument is operated as described in paragraph 45c, for the Swasey D. P. F. The target is tracked in azimuth by means of the handwheel (3) and in range by means of the handwheel (21). The same precautions apply to this instrument as to the M1907 D. P. F. (par. 46c(2)).

SECTION IV

SELF-CONTAINED BASE INSTRUMENTS

■ 48. PRINCIPLES.—*a. Geometric principles.*—The modern horizontal base self-contained range finder is designed to

determine the range to a target by the same general geometric principles as those used in the depression position finder. The base line, being contained within the instrument, is extremely short in comparison with the range to be determined, consequently the angles measured are small. In order to get accuracy comparable to that of other systems, the very

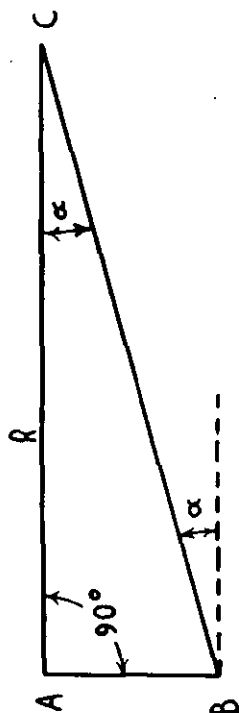

FIGURE 24.—Geometric principles of self-contained range finder.

small changes of the small angles measured must be determined with precision. The triangle solved by a range finder is shown in figure 24. AB is the base line, C is the target, and AC is the range R . In any selected instrument, the length of the base line and the angle at A are main-

tained constant in value. The scale on which the angle α is read may then be graduated to read directly in range.

b. *Optical principles.*—There are two common methods of determining the angle α , the coincidence method and the stereoscopic method:

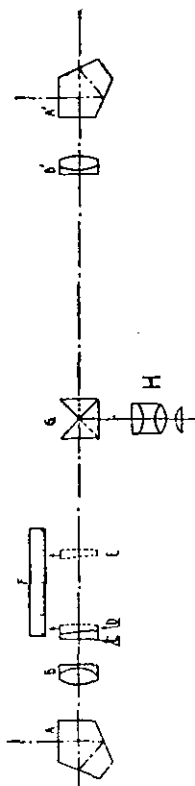

FIGURE 25.—Elements of coincidence range finder.

(1) *Coincidence method.*—(a) Figure 25 is a diagrammatic sketch of the main features of a coincidence range finder. A and A' are two penta prisms at the ends of the base line, B and B' are the objective lenses, C and D are measuring prisms,

E is any position of *D* when reading a range, *F* is the range scale, *G* is an ocular prism, and *H* is the eyepiece. The penta prisms *A* and *A'* turn the rays of light through an angle of 90° ; the distance between them determines the length of the base line. The measuring prisms *C* and *D* are wedge-shaped: they are identical and are placed one inverted with respect to the other so that all rays of light passing through them will emerge parallel to their original course. The functioning of these prisms is as follows: The ocular prism *G* serves two purposes; it divides the image into halves by cutting off along a straight line the lower half of the rays that come from one end of the instrument and the upper half of the rays that come from the other end, and it turns the reflected rays through 90° , toward the eyepiece *H*. The observer at the eyepiece sees a composite view, one half of the image coming through *A*, *B*, *C*, and *D*, and the other half coming through *A'* and *B'*. The dividing line between the halves is horizontal and very sharp and distinct.

(b) If the range finder illustrated in figure 25 is directed at a vertical target such as the mast of a ship, and if the target is at an infinite distance, rays of light from it entering the two ends of the range finder will be parallel, and the parallax angle α will be zero. If the instrument is properly adjusted with prisms *C* and *D* in contact, each ray of light will be reflected through two right angles, and the resulting image will not be distorted in any way. The upper half of the mast will be exactly over the lower half as at (2), figure 26, and the two images will be in coincidence.

(c) If the same range finder is now directed at a similar target at a finite range, the rays of light from the target entering the instrument will no longer be parallel and, therefore, the resulting image will no longer be undistorted. One half of the image will be displaced with respect to the other half, as at (1), figure 26, and the amount of the displacement will be a measure of the parallax angle α and, therefore, of the range. It is the purpose of the measuring prisms *C* and *D* to measure this displacement. When the prism *D* is moved away from the fixed prism *C*, a ray of light will no longer emerge from the prisms in its original course but will be refracted by both, and the amount of the refraction will be

proportional to the distance through which prism *D* is moved. The effect of the movement of prism *D* on the image, as seen through the eyepiece, is to move the half of the image which has passed through *A*, *B*, *C*, and *D* laterally by an amount directly proportional to the distance that the prism *D* has been displaced. By regulating the position of the movable prism *D*, the observer can bring the halves of the image into coincidence and, since the distance that the movable prism

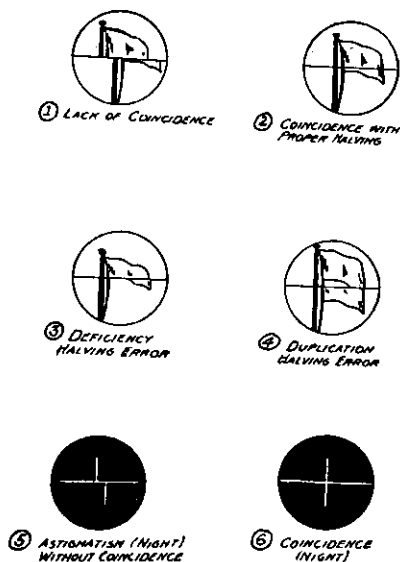

FIGURE 26.—Appearance of target in coincidence range finding.

must be displaced is inversely proportional to the range to the target, the scale *F* may be graduated in ranges and the range to the target indicated on that scale.

(d) Since the measuring prisms used are only very slightly wedge-shaped, appreciable displacement of the movable prism is required to obtain coincidence even for small changes in the parallax angle α . Therefore much greater accuracy may be obtained than by measuring the parallax angle di-

rectly or by measuring the displacement of the halves of the image.

(2) *Stereoscopic method.*—(a) The stereoscopic method of range finding is based on the principle of stereoscopic vision, a principle which is not involved in any of the methods previously discussed. Stereoscopic vision, or depth perception, depends upon seeing simultaneously two views of the same object taken from slightly different viewpoints. It therefore depends on the use of both eyes. It is one of the means by which we can tell which of two objects is closer to us. The stereoscopic sense alone does not permit of great accuracy in the direct estimation of distances but, using this sense, an observer can tell with considerable accuracy when two objects are at the same distance from him. It is this latter ability which is used in stereoscopic range finders.

(b) Figure 27 is a schematic diagram showing the elements of a simple stereoscopic range finder. The essential features are the penta prisms B_R and B_L , which reflect through right angles the light rays that enter each end of the instrument; the objectives O_R and O_L ; the mirrors M_R and M_L , acting to reflect the light rays through right angles once again; the reticles R_R and R_L , with their symbols (indicated by the small circles) engraved thereon; the eyepieces E_R and E_L ; and the two adjusting prisms or wedges, one of which, W_F , is fixed, and the other, W_M , movable. These wedges are identical in shape but one is inverted when mounted in position. When the movable wedge W_M is moved to the left so that the surfaces of the two wedges touch, the exterior faces are parallel and hence light rays will pass through without appreciable refraction. When the wedges are separated, each refracts a light ray passing through by an equal amount but in opposite directions. The path of a ray emerging from the left of W_F is parallel to its direction when it enters from the right of W_M . The action of the two wedges is to displace the ray by an amount proportional to the distance between the wedges without changing the resulting direction of the ray. In the latest instruments, the movable wedge W_M is not moved laterally as shown in the diagram, but both wedges are rotated in surface contact. The result is the same.

(c) Suppose the range finder is directed at an object at an infinite range, for example, a star. Light rays entering B_R and B_L will be parallel and will be reflected along the axis of the instrument to M_R and M_L and then to R_R and R_L , where the two images of the star will coincide with the reticle symbols, provided, of course, that the wedge W_M is in its infinity position, that is, against W_F . When the observer looks through the eyepieces, he will merge the two images of the star and the two images of the reticle symbol into one, and both objects will appear to be at point 1. (To make the figure clear, the distance between the eyepieces

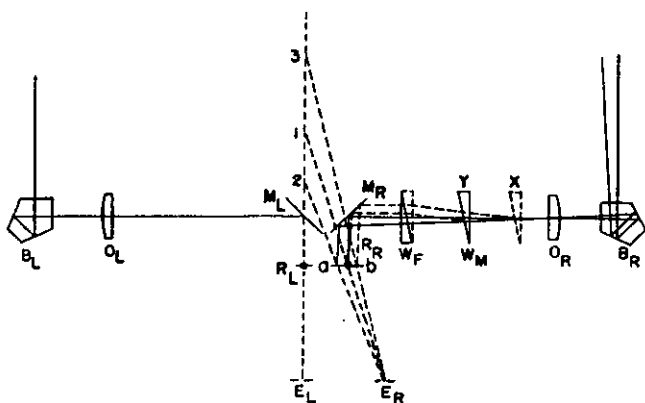

FIGURE 27.—Elements of stereoscopic range finder.

has been greatly exaggerated.) Now suppose the range finder is pointed at some target at a finite distance. The rays of light entering B_L and B_R will no longer be parallel. The instrument will be traversed so that the ray entering B_L will be perpendicular to the axis of the instrument. The left image of the target will be reflected, as before, to the left reticle at the same place as the symbol. The ray entering B_R will not be perpendicular to the instrument's axis, and hence if W_M is touching W_F , the right image of the target will be reflected to some point on the reticle as that marked a . To the observer, the target will seem to be at point 2,

short of point 1, where the reticle symbols still appear to be. If W_M is displaced to the right to the position marked X , the ray of light will, through the double refraction of the two wedges, be displaced so that it is reflected on the reticle at the point marked b . The target will now appear to be at point 3, at a greater range than that to the apparent position of the object formed by the reticle symbols. At some intermediate position, such as that marked Y , the displacement of the light ray caused by the two wedges will be sufficient to cause the ray to be reflected on the reticle where the symbol is engraved. The target and reticle symbols will both appear to be at the same range, both appearing to be at point 1, and stereoscopic contact will have been established. The movement of the wedge W_M , which is proportional to the distance to the target, is measured on a scale which is graduated in terms of ranges. For a comprehensive description of this method of range finding and of instruments of this type see TM 4-250.

■ 49. DESCRIPTION.—*a.* Self-contained range finders are designed for determining both ranges and azimuths at the same time, although in practice they are not always so used. (See par. 16.) They are usually provided with an auxiliary sight at which a tracker is stationed to assist the observer in tracking the target. There are three principal parts to a self-contained instrument, the range finder containing the optical system and the measuring mechanism, the base containing the tracking and leveling mechanism, and the tripod or mount. The methods of indicating azimuth and range are similar to those previously described for other instruments.

b. Instruments of different characteristics, some of the coincidence type and some of the stereoscopic type, are in service. The principal characteristics which differ are the base line lengths (from 9 to 30 feet), the power (from 15 to 30), and the maximum range which the instrument is capable of determining. The stereoscopic height finder M1 originally designed for antiaircraft artillery has been adopted as the standard self-contained range finder for seacoast artillery.

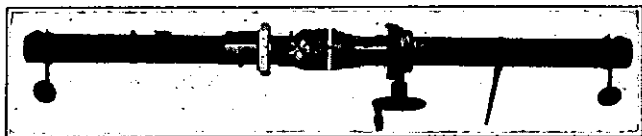

FIGURE 28.—9-foot range finder (coincidence type).

■ 50. ADJUSTMENT.—The exact method to be used to adjust each particular instrument is described in a pamphlet or handbook furnished with the instrument. The following descriptions of methods apply generally to instruments of the type mentioned or to the particular instrument mentioned in each case. The adjustments required are the leveling of the instrument; the setting of the interpupillary distance for the observer's eyepieces (stereoscopic type only); the focusing of the eyepieces; the collimation of the tracker's telescope (if provided) with the observer's line of vision; the halving adjustment for the coincidence type or the height of image adjustment for the stereoscopic type; and the range adjustment.

a. Leveling.—This operation is performed as previously described for other instruments.

b. Interpupillary distance.—The interpupillary distance is the distance between the pupils of the observer's eyes. The eyepiece should be set at this distance. It is particularly important that this setting be made accurately or stereoscopic observation will be inaccurate. Each observer should determine his proper setting and should habitually make this setting as soon as he arrives at the instrument.

c. Focusing of eyepieces.—This operation is performed as previously described for other instruments.

d. Collimation of tracker's telescope.—This operation consists of making the line of sight of the tracker's telescope converge at the desired range with that of the observer. It is done by pointing the instrument, by means of the observer's telescope, at a point of suitable range and adjusting the tracker's telescope to intersect that point.

e. (1) Halving adjustment.—This adjustment is required when the two images formed by the rays of light entering the two ends of the coincidence range finder from the target are not reflected along the same horizontal line. When this is

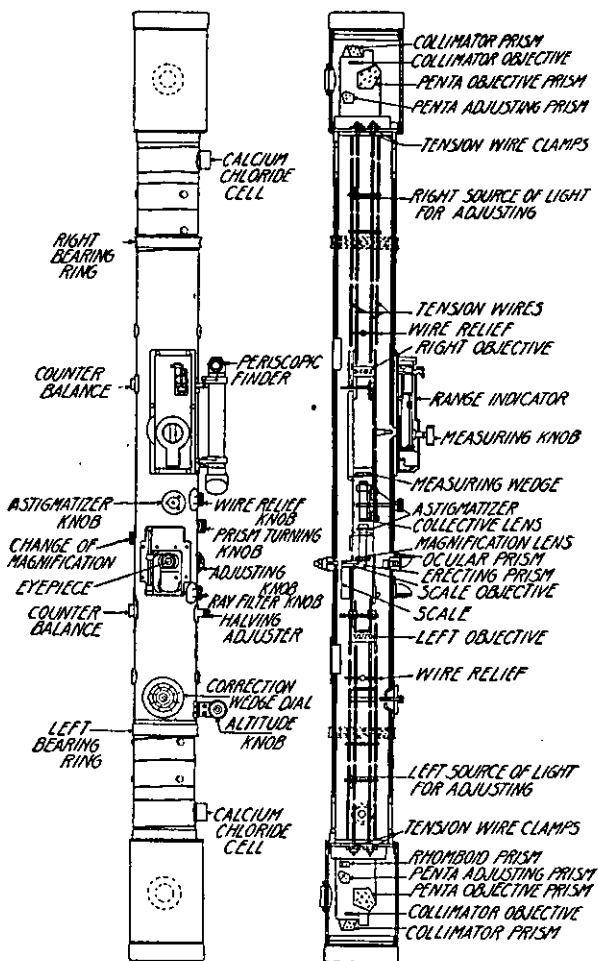

FIGURE 29.—15-foot range finder (coincidence type).

the case a portion of the target may not be visible (deficiency halving error, fig. 26 ③), or the same portion of the target may be seen in both the upper and lower half of the field of view (duplication halving error, fig. 26 ④). Except for the distorted view of the target, these errors are not serious if the portion of the target upon which coincidence is being obtained is perpendicular to the dividing line of the field of view. If it is not perpendicular an appreciable error will be introduced. In ③ and ④, figure 26, if coincidence had been obtained on the right edge of the flag instead of on the staff the results would have been quite different. The adjustment is made by means of a prism in one end of the instrument. By moving this prism, the observer moves the rays of light passing through it vertically until that half of the image formed by these rays is reflected along the same horizontal line as the rays forming the other half of the image.

(2) *Height of image adjustment.*—The height of image adjustment of a stereoscopic range finder corresponds to the halving adjustment of the coincidence range finder. If in a stereoscopic instrument one image is higher or lower than the other, the observer will undergo considerable strain in fusing them into a single object, and stereoscopic observation will be hampered. If the images are considerably separated he will be unable to fuse them at all, and stereoscopic observation will be impossible. The adjustment is made in the same way as for the halving adjustment.

f. Range adjustment.—(1) For a coincidence type instrument (fig. 29), this adjustment is made preferably by use of a datum point at known range. The instrument is set to register the range to the datum point. If the partial images do not coincide, the correction wedge dial is carefully moved until coincidence of the partial images is properly defined. The coincidence adjustment should be checked at two or more known ranges, one of which should be at the longest range at which good definition can be obtained. This adjustment should be made with great care preferably under favorable weather conditions. When there are no objects at known ranges from the instrument or when the adjustment must be made at night and there are no fixed lights at known ranges, the moon or a bright star may be used as an infinite point for

obtaining coincidence. The astigmatizer is employed in making this adjustment, causing the star or moon to appear as a streak of light. Proceed as for an object at known range, revolve the measuring knob until the measuring scale registers infinity, and then rotate the correction wedge until the lower and upper halves of the streak of light are in coincidence.

(2) For a stereoscopic height finder M1 (par. 49), the adjustment is made preferably by an internal adjuster. This adjuster consists of a special optical system which reflects rays of light from a single light source within the instrument into the main penta prisms of the range finder. These rays of light are parallel and therefore the source of light appears to be at infinity. The range scale is set to read infinity, and the observer makes stereoscopic contact with the internal adjuster target and reticle symbol using the correction knob instead of the measuring knob. The range scale does not move but remains set at infinity. The range corrector setting is read from its scale. At least ten readings are taken and the average determined for the correct setting. The range corrector setting may be determined in the same manner by making stereoscopic contact when sighting on a celestial body at night or on an adjusting lath furnished with the instrument. The lath consists of a simple bar on the ends of which are mounted two identical targets separated from each other by exactly the same distance as the length between the windows of the range finder. When the lath is set up parallel to the tube of the range finder the lines of sight from the ends of the tube to the corresponding targets are parallel, and the observer sees a single target at an apparent range of infinity. In using the lath it is necessary to introduce an additional lens in each telescope to permit focus on a near object since the instrument is normally focused at infinity. Another means of making the adjustment is by use of a datum point at known range. The known range is set and a series of stereoscopic contacts is made as previously described.

(3) For a self-contained instrument, the range adjustment varies with the observer, the visibility, the temperature, and the condition of the instrument. If any of these factors changes a new range adjustment should be made. *There-*

fore, the adjustment should be checked at frequent intervals—at least once each hour during operation.

■ 51. OPERATION.—*a.* A self-contained range finder is operated by from one to four men. The 9-foot coincidence range finder (fig. 28) is operated normally by one man, an observer, who observes with the right eye in one eyepiece and reads ranges with the left eye in another eyepiece. An instrument of the type shown in figure 29 is operated by two men, an observer and a trainer. The trainer identifies the target by using the finder, bringing the intersection of the finder cross wires on the portion of the target most suitable for observation. Ranges are read from the inside range scale or from the outside range indicator. The operation of a stereoscopic range finder requires four men: a stereoscopic observer, a lateral tracker, a vertical tracker, and a range reader.

b. With any instrument the observer receives the command assigning the target and tracks the target in range. When using a coincidence range finder he should select some part of the target which will allow coincidence to be made on a well-defined line perpendicular to the halving line; when using a stereoscopic range finder he should place the reticule symbols near but not in contact with the image of the target. At intervals indicated by the TI bell or buzzer (par. 16), he takes an observation and stops tracking momentarily to read or permit the reader to read the range and transmit it to the plotting room. The trackers on a stereoscopic instrument assist the observer by tracking the target in direction and in elevation.

c. The range finder should be located where there will be minimum interference with observation due to the smoke and blast of firing. Since the accuracy of a stereoscopic instrument is affected by rapid changes in temperature and by unequal changes in the temperature of different parts of the tube, the instrument should be so located that the tube is not subjected to changes of sunshine and shade. If possible, it should be located so that the observer will not be forced to observe through heat waves reflected from such surfaces as sand and concrete. The observer should not be required to

observe over long periods of time. Fifteen minutes should be the maximum duration of any one observing period; the accuracy of observations extended over longer periods is likely to be greatly reduced due to eyestrain and fatigue.

d. The target is tracked in azimuth by a separate observation instrument placed near the range finder. The operation of tracking in azimuth is described in paragraph 42.

CHAPTER 8

REFERENCE NUMBERS

■ 52. GENERAL.—Reference numbers are used extensively in all position finding systems to expedite the transmission of data and minimize the possibility of mistakes. They are arbitrary numbers employed to represent actual values of units of measure used in seacoast artillery firing. The reference number representing zero units is called the “normal,” and is so selected in the series as to avoid the use of plus or minus, up or down, and right or left. There are several systems of reference numbers that are used in seacoast artillery firing. Examples are given in paragraphs 53 to 56, inclusive.

■ 53. DEFLECTION.—Deflection for all seacoast artillery except those 155-mm guns which have not yet been converted is measured in degrees and hundredths. (See note, par. 12.) The original system was from approximately 1.00 to 5.00 with 3.00 as the normal. In this system a deflection of left 1.20° is represented by a reference number of 1.80, and a deflection of right 1.20° by a reference number of 4.20. Due to the increased range of modern cannon and to the higher speeds of targets, with the consequent possibility of larger deflections, this system was found to be inadequate. There are two new systems in use, one with a normal of 6.00 and the other with a normal of 10.00. Deflection for 155-mm guns not yet converted to degrees is measured in mils; the normal of the scale is 300. All instruments on which deflections are set are provided with a scale of reference numbers. The interior scales of azimuth instruments (par. 42) are graduated in reference numbers for deflection but with the scale reversed so that deviations to the left read greater than normal. With this arrangement the reference number of the deviation is the same as that of the deflection to be set on the gun sight in order to correct for that deviation.

■ 54. ANGULAR TRAVEL.—On the plotting board, M1904 (par. 67), angular travel is measured in degrees and hundredths. The reference numbers have a normal of 15.00. In this system a rate of angular travel of left 1.35° is represented by a reference number of 13.65, and a rate of angular travel of right 1.35° by a reference number of 16.35. These reference numbers are used also on the travel computing mechanism of the deflection board, M1905. The reference numbers on the travel computing mechanisms of the deflection board M1 are in degrees with a normal of 6.00.

■ 55. WIND.—The speed of the wind is measured in miles per hour. The reference numbers have a normal of 50. A tail wind (tending to assist the projectile in flight) and a wind blowing the projectile to the left are represented by a reference number greater than 50; a head wind (tending to retard the flight of the projectile) and a wind blowing the projectile to the right, by a reference number less than 50. This system is used on the wind component indicator, on the range correction board, and on the deflection board.

■ 56. RANGE DEVIATIONS AND CORRECTIONS.—*a.* Range deviations and corrections usually are determined in terms of percentage of the range with a unit of one-tenth of one percent. The reference numbers for this element of data have a normal of 300. In this system, a deviation of over 1.5 percent or a correction of plus 1.5 percent is represented by a reference number of 315 ($300+15$), and a deviation of short 1.5 percent or a correction of minus 1.5 percent by a reference number of 285 ($300-15$).

b. On the correction slides (for range) on the M1904, M1906, M1906M1, and M1911 plotting boards (pars. 67, 70, and 71) the normal of the scales is 2,000, corrections being set in yards.

CHAPTER 9

PLOTTING BOARD ACCESSORIES

	Paragraphs
SECTION I. Prediction scale.....	57-58
II. Set-forward rule.....	59-61
III. Set-forward chart.....	62-63
IV. Set-forward scales.....	64-65
V. Targ.....	66

SECTION I

PREDICTION SCALE

■ 57. DESCRIPTION.—The prediction scale (fig. 30) is an instrument issued for use in measuring the rate of linear travel of the target and, with a set-forward rule or chart (see pars. 59 to 63, incl.), in locating the set-forward point on a plotting board. The instrument consists of a straight piece of metal with both edges beveled. Each beveled edge is graduated uniformly from the center outward in both directions with zero at the center. The graduations are so arranged that the scale may be read from either side. Two small knobs are provided for handling. A prediction scale is graduated to correspond with the scale of the plotting board with which it is to be used.

■ 58. OPERATION.—In locating the set-forward point—

a. The zero graduation is placed at the last plotted point and the distance between the last two plotted points is measured.

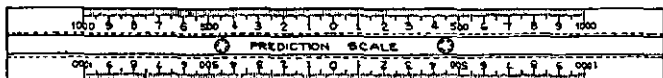

FIGURE 30.—Prediction scale.

b. The distance plotted is the linear travel of the target during the dead time plus the time of flight of the projectile.

SECTION II

SET-FORWARD RULE

■ 59. DESCRIPTION.—*a.* The set-forward rule (fig. 31) is for use with the prediction scale to determine the location of the set-forward point. It solves the equation

$$Y = \frac{X}{M}(t + D)$$

where

Y = travel during time of flight plus dead time

$\frac{X}{M}$ = rate of travel (yards/seconds)

t = time of flight

D = dead time

b. The mechanical construction of the rule is the same as that of an engineer's slide rule. The body is divided by an undercut slot in which a slide travels. Mathematically, the rule is a logarithmic slide rule. Values of X are represented on the lower scale, which is a logarithmic scale of values from 50 yards to 700 yards with log 50 as the origin. Values of the factor $\frac{(t + D)}{M}$ are represented on the scale on the slide. This is a logarithmic scale for values of the factor when $D=60$ seconds, $M=60$ seconds, and t is varied from 20 to 75 seconds. The scale, then, covers the values of the factor from 1.333 to 2.250 with log 1.333 as the origin. The scale is marked in terms of time of flight for ease in use. Values of Y are represented on the upper scale, which is a logarithmic scale for values from 100 to 1,300 yards with log 100 as the origin. All scales are graduated to the scale of 1 inch = 0.1216 logarithmic units (approximately). This rule is satisfactory for a dead time of 60 seconds and for an observing interval which is any submultiple of 60 seconds. A new scale for the factor $\frac{(t + D)}{M}$ must be constructed for any other combination of observing interval and dead time. The rule shown provides for a maximum target speed of slightly over 20 knots (travel = 700 yards per minute). For use when firing at modern high-speed targets a rule should be constructed to provide for speeds up to 45 knots (travel = 1,500 yards per minute) or greater.

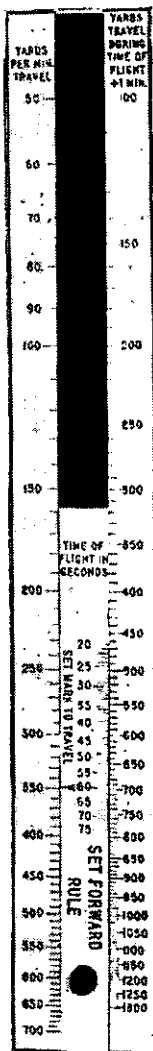

FIGURE 31.--Set-forward rule.

■ 60. OPERATION.—In operating the set-forward rule, the time of flight and the travel during 1 minute must be furnished the operator. Since the time of flight depends on the result of the operation in which it is used, its true value can be obtained only after a series of approximations. In actual practice, the time of flight to the last (preceding) set-forward point is usually sufficiently accurate for this purpose. The operator of the rule notes the range to the last set-forward point as called out by the plotter and uses the time of flight corresponding to that range. The travel during 1 minute is called out by the plotter. The operator of the rule sets the index (arrow) opposite the correct value of the yards per minute travel, on the lower scale. Opposite the proper time of flight he reads the yards travel during the time of flight plus 1 minute, from the upper scale. The plotter then locates the set-forward point at that distance ahead of the last plotted point and on the expected path of the target.

NOTE.—The use of this rule requires that the time of flight for the particular range be known. This conversion of range to time of flight may be accomplished directly by graduating the time of flight scale on the rule in terms of range for the particular gun being used.

■ 61. NOTES ON CONSTRUCTION.—*a.* Although only a new scale for the factor $\frac{(t+D)}{M}$ is necessary for a new combination of observing interval and dead time, some advantage will be gained by constructing a complete rule. First, the scale of the rule may be enlarged to give more space for graduating the rule. Secondly, the *X* scale and the $\frac{(t+D)}{M}$ scale may be interchanged to speed up the operation of the rule. This will allow the operator to keep the index on the slide set at the time of flight to the set-forward point. The slide is then in position so that all *X* values are under the corresponding *Y* values for that particular time of flight, and the operator may read the travel to the set-forward point as soon as the plotter calls out the rate of travel. The following notes will be of assistance in the construction of a set-forward rule:

(1) Use material that is insensitive to temperature changes.

(2) Use a scale of about 1 inch=0.05 of a logarithmic unit.
 (3) Use five-place logarithms in calculations for constructing the scales and calculate the scaled distances to two decimal places.

(4) Plot graduations for every 10 yards on the X and Y scales.

(5) Plot graduations for each second of time of flight (within the selected limits) on the $\frac{(t+D)}{M}$ scale.

(6) Locate all scales centrally on the rule. The position of the setting index on the slide may be determined as follows:

Set the X scale under the Y scale for any ratio, such as $Y:X=2:1$. Place the index opposite the graduation on the $\frac{(t+D)}{M}$ scale representing that value of the time of flight that makes the factor $\frac{(t+D)}{M}$ equal to 2.0.

(7) Label the rule clearly with the values of D and M for which it is constructed.

(8) For details on the construction of logarithmic scales see appendix II.

b. In selecting the value of M for use in measuring the rate of travel, it is necessary that it be equal to or some multiple of the observing interval. The usual practice is to take M equal to two observing intervals. This procedure will generally give smoother readings of the travel than when only one observing interval is used.

SECTION III

SET-FORWARD CHART

■ 62. DESCRIPTION.—The set-forward chart is a device for solving the equation

$$Y = \frac{X}{M}(t + D)$$

in chart form. It is designed to replace the set-forward rule. The chart consists of a tabulation of the values of Y for all values of X and t within the selected limits, with D and M as constants. In each row the value of t is held constant and X is increased by 10-yard increments from left to right. In each column the value of X is held constant and t is in-

SET-FORWARD CHART

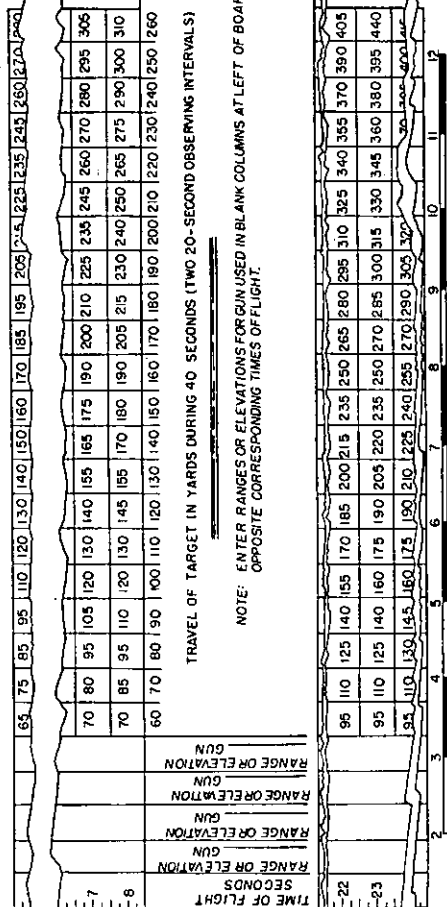

Figure 32.—Set-forward chart.

creased by 1-second increments from top to bottom. The values of Y are shown to the nearest 5 yards. The values of t are shown in the left-hand column. The values of X are shown on a T-square which rides on the board. The ranges corresponding to the times of flight for a particular combination of gun, projectile, and powder charge may be shown in another column on the board. Figure 32 shows a portion of a set-forward chart. The values used in the formula for constructing the chart shown in the figure are—

$X=60$ to 260 yards

$t=3$ to 54 seconds

$D=40$ seconds

$M=40$ seconds

NOTE.—The chart shown provides for a maximum target speed of about $12\frac{1}{2}$ knots (400 yards per minute). For use when firing at modern high-speed targets the chart should be extended to provide for speeds up to 45 knots (1,500 yards per minute) or higher.

■ 63. OPERATIONS.—*a.* In operating the set-forward chart the time of flight (or range) and the rate of travel must be furnished the operator. The operator sets his T-square at the time of flight (or range) of the last set-forward point. Opposite the rate of travel as called out by the plotter, he reads the yards' travel to the set-forward point to the plotter. The plotter then locates the set-forward point as before.

b. There is little choice between the rule and the chart. A rule may be constructed that can be read as easily as a chart, making the possibility of errors of operation equal. The principal source of error in the use of either instrument is the possibility of error in transmission between the plotter and the operator of the chart or rule.

SECTION IV

SET-FORWARD SCALES

■ 64. DESCRIPTION.—To obviate the necessity for a prediction scale and a set-forward rule (or chart) and to enable the plotting of the set-forward point by a single operation, a series of scales is sometimes constructed. These are called

"set-forward scales." (See fig. 33.) Each scale of the series has on it two sets of graduations with a common zero near the center. The set of graduations in one direction is drawn

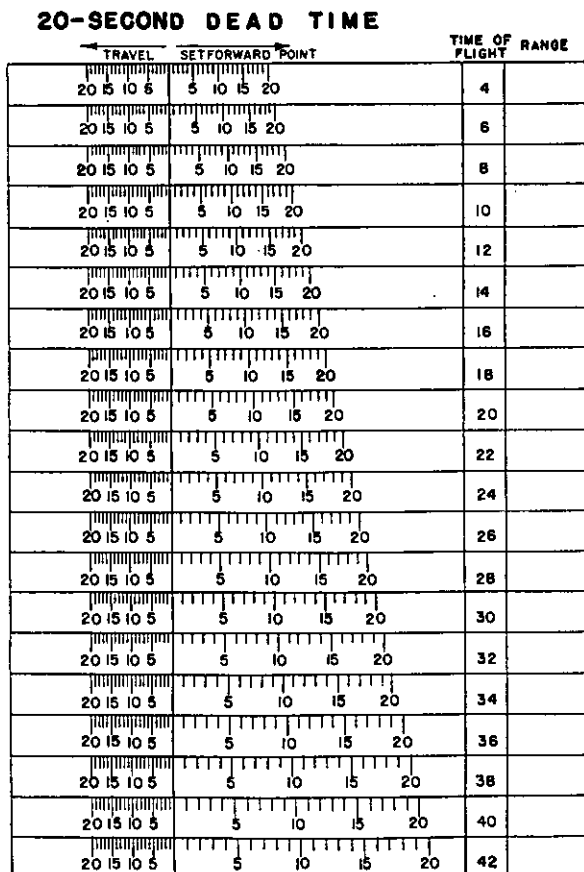

NOTE: ON EACH SCALE, TABULATE RANGE
CORRESPONDING TO TIME OF FLIGHT.

FIGURE 33.—Set-forward scales.

in reference numbers to any convenient scale and represents travel of the target (X). The set in the other direction is to a scale

$$\frac{(t+D)}{M}$$

times as large and represents the values of Y for corresponding values of X . A separate scale must be constructed for each value of t . Usually each scale is designed to be used for a range zone about 2,000 yards deep, that is, for a particular series of ranges covering about 2,000 yards—from 5,000 to 7,000 yards, for example. The time of flight for the middle of the range zone—for 6,000 yards if we are considering the range zone extending from 5,000 to 7,000 yards—is assumed to be sufficiently accurate for all ranges in the zone. One set of scales is equally suitable for all scales of the plotting board but is accurate only for the particular values of D and M used in their construction. A series is therefore required for each particular combination of D and M used. Set-forward scales cannot be conveniently or accurately used for mortars or for guns when firing at high angles of fire. Such scales are not articles of issue and when desired must be constructed locally. If made of paper they should, for convenient use, be cut up and pasted on metal strips and placed in a portable rack so that they are readily accessible to the plotter.

■ 65. OPERATION.—*a.* The plotter selects the proper scale for the current range. He places the zero of the scale at the last plotted point and measures the distance to the preceding plotted point on the X scale. He marks the set-forward point the same number of graduations ahead of the zero mark on the Y scale.

b. Since this method of locating the set-forward point requires the service of only one man, no transmission of data is necessary. This removes the possibility of errors in transmission, speeds up the operation, and lessens the noise in the plotting room. On the other hand, it introduces a new source of error because of the possibility that the plotter may select the wrong scale for the current range.

SECTION V

TARG

■ 66. DESCRIPTION AND OPERATION.—The targ is an instrument used to mark the successive positions of the target and to assist in the reading of azimuths and ranges on the board. It is wedge-shaped with a pushpin arrangement at the apex for indenting the paper covering the plotting board.

CHAPTER 10

PLOTTING BOARDS

	Paragraphs
SECTION I. Plotting board, M1904 (Whistler-Hearn).....	67-69
II. Mortar plotting boards.....	70-71
III. 110° plotting boards, M1915, M1918, and M3.....	72-74
IV. Plotting and relocating boards, M1923 (Clove), and M1.....	75-77

SECTION I

PLOTTING BOARD, M1904 (WHISTLER-HEARN)

■ 67. DESCRIPTION.—The plotting board, M1904 (fig. 34), is an older type board for use with fixed seacoast artillery guns and howitzers. It provides means for locating the target by either the two-station (horizontal base) or the single-station (vertical or self-contained base) method, for locating the set-forward point, for relocating the set-forward point in range and azimuth from the directing point when using case III pointing, and for determining the rate of angular travel of the target from the directing point when using case II pointing.

The board proper is a wooden drawing board, slightly more than a semicircle, mounted on two trestles to place it at a convenient height for use. A piece of drawing paper may be mounted on the board for use in tracking a target.

A base line arm is placed along the rear edge of the board parallel to the diameter of the circle. The positions of the observation stations are represented on that diameter by station blocks placed on the base line arm. The primary station is at the center of the circle. The secondary station block may be moved along the base line arm. It is placed on that arm at its proper distance to the right or left of the primary station by means of scales on the base line arm. A vernier on the station block permits setting the length of the base line to the nearest yard.

The position of the directing point is represented by the point about which the gun arm pivots in the gun arm cen-

ter. It is located with respect to the primary station by offsets, one along the base line and the other perpendicular to the base line. Those offsets are set off to scale by means

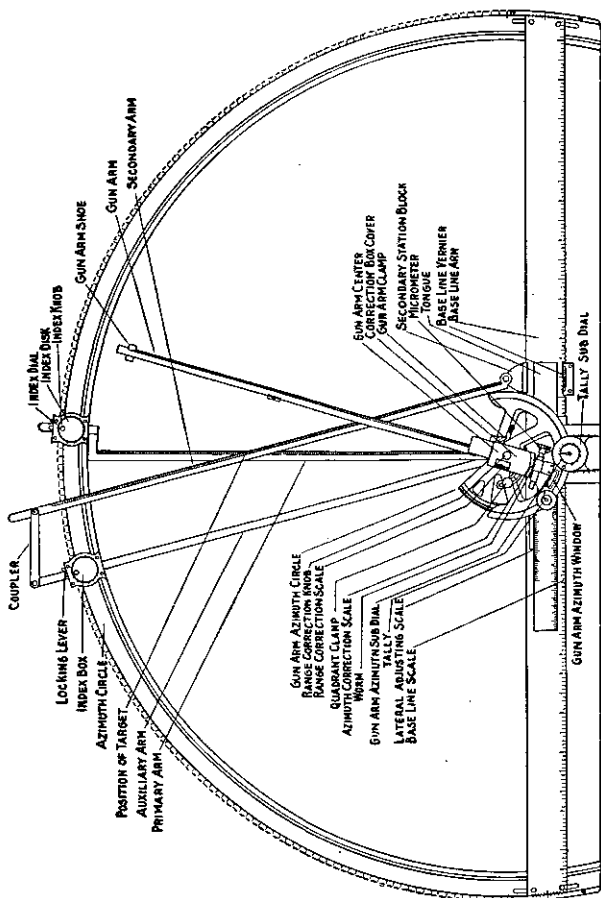

FIGURE 34.—Whistler-Hearn plotting board for guns.

of the lateral and the longitudinal adjusting slides attached to the base line arm.

Metal arms are pivoted at the positions of the two observation stations and the directing point to represent the lines of sight from those points to the target. These arms are referred to as the primary, secondary, and gun arms. Their reading edges are graduated in yards of range to the scale of the board.

The normal scale of the board is 300 yards to the inch, but gun arms graduated to a scale of 450 yards to the inch have been issued to the majority of major caliber batteries to increase the field of fire for which the board may be used. The scale of the station arms must conform to that of the gun arm used.

The outer edge of the board forms an arc of a circle about the primary station as a center. This circle is called the "main azimuth circle." Notches are cut at 1° intervals along the circumference of this arc. An azimuth scale is inserted in the main azimuth circle with graduations to cover the azimuths in the semicircle to the seaward of the base line for the selected set-up. The limiting azimuths are the azimuth and back azimuth from the primary to the secondary station to the nearest full degree. Verniers graduated in hundredths of a degree are provided at each end of the base line arm by which that arm may be set on one end to the exact azimuth and on the other end to the exact back azimuth of the base line from B^1 to B^2 .

The primary arm is set to the azimuths sent in from the primary station by means of the main azimuth circle and an index box attached to its outer end. The index box provides means for locking the arm in the notches of the main azimuth circle and for setting off hundredths of a degree.

Since the secondary arm is pivoted at some point other than the center of the main azimuth circle, an auxiliary arm and a coupler are provided in order that the same azimuth circle may be used for setting azimuths from the secondary station. The auxiliary arm is pivoted above the primary arm at the primary station. The coupler is a piece of metal equal in length to the base line, that is, to the exact distance between the centers of the primary and secondary station block pivots. It connects the outer ends of the secondary and auxiliary arms by pivots about which the two arms

turn as they are moved in azimuth across the board. The coupler remains parallel to the base line, and the secondary arm remains parallel to the auxiliary arm. An index box is placed on the auxiliary arm, and that arm is set to the azimuths sent in from the secondary stations. Since the secondary arm is held parallel to the auxiliary arm it will also be set at the azimuths sent in from the secondary station.

To allow intersection of the primary and secondary arms at extreme ranges on the board without interference of the primary arm index box, the primary arm is offset at its outer end. (See fig. 34.) The azimuth scale is therefore a double scale with an outer row of graduations for the primary arm and an inner row for the secondary arm.

The degrees of azimuth of the gun arm are read from the gun arm azimuth circle on the gun arm center. The hundredths of a degree are read from the gun arm azimuth subdial which is geared to the gun arm center.

Angular travel is read in reference numbers on the tally dial and the tally subdial, degrees on the former and hundredths of a degree on the latter. The dial and subdial are actuated by movement of the gun arm.

The gun arm center is provided with a correction slide and an azimuth correction scale on which flat corrections in range and azimuth may be applied to the uncorrected range and azimuth of the set-forward point. These devices are graduated in reference numbers, with the normal of the former 2,000 and of the latter 15.

The center line of the board is the radius that divides the board into halves. It passes through the center notch in the main azimuth circle and the center of the primary arm pivot, and is perpendicular to the base line arm when the base line verniers are set at zero.

■ 68. ORIENTATION.—*a. Base line arm and main azimuth circle.*—(1) The first problem is to determine the proper degree readings that should be inserted along the circle. As stated before, those readings are determined by the azimuth and back azimuth of the base line from the primary station, the nearest full degree being taken. For example, assume

that the board is to be oriented for a left-handed base line the azimuth of which is 212.14° (zero south) from B^1 to B^2 . The azimuth circle should then read azimuths from 212° to 32° , with 212° on the left end of the base line arm. If the base line were right-handed and the azimuth 212.80° , the azimuth circle should read azimuths from 33° on the left to 213° on the right end of the base line arm. If the main azimuth circle is properly oriented, the center line of the board will coincide with the perpendicular to the base line to the nearest full degree. This azimuth scale is usually marked by Ordnance Department before the board is issued to the using battery.

(2) The next operation is to set the base line arm to the exact hundredth of a degree of the azimuth. In the first example, the base line arm should be rotated clockwise through 0.14° . In the second example it should be rotated counterclockwise through 0.20° . To prevent errors, both verniers should be used and both ends of the base line arm should be set accurately.

b. Secondary station.—Set the station block of the secondary station at the distance (to scale) from the primary station equal to the length of the base line, to the right for a right-handed base line and to the left for a left-handed base line. The approximate position of the station block is marked by a countersunk recess in the board.

c. Gun arm center.—The gun arm azimuth circle on the gun arm center must be oriented to read the azimuth of the gun arm, and the gun arm center must be moved to the position of the directing point. To orient the gun arm azimuth circle, bring the gun arm center over the primary station by setting the zeros of the longitudinal and lateral adjusting slide verniers to the zeros of their respective scales. Set the azimuth correction scale to normal by bringing the zero of the worm gear to 15 on the scale and setting the scale of hundredths on the micrometer head to zero. Set the primary arm to the azimuth of the center line of the board (with the index disk on the primary arm at zero). Place the targ against the reading edge of the primary arm and bring the gun arm against the targ. The gun arm is now pointing at the same azimuth as the primary arm. By means of the

adjusting screw, set the azimuth pointer at the gun arm window to the whole degree of azimuth of the center line of the board. If necessary move the markings of the gun arm azimuth circle until this can be done. Next set the gun arm azimuth subdial indicator to zero. The indicator may be adjusted to the nearest $\frac{1}{4}^\circ$ by loosening the screw holding it in place. Finer adjustment must be made by loosening the azimuth subdial retaining screw and moving the subdial until the pointer is at zero.

NOTE.—The tally subdial must be removed to allow access to the azimuth subdial retaining screw.

The final setting should be verified by bringing the gun arm against the targ several times and checking the readings. The gun arm center should now be moved to the position on the board corresponding to the position of the directing point. This is done by setting the proper values of the offsets from the primary station on the longitudinal and lateral adjusting scales.

■ 69. OPERATION.—The number of men necessary for the operation of the plotting board, M1904, and the operations performed on the board depend upon the method of locating the target (two-station or single-station), the method of pointing (case II or case III), and the method of predicting (by prediction scale and set-forward device or by set-forward scale). The operation is most complete when using the two-station method with case II pointing and the prediction scale and set-forward device. Therefore, operation under those conditions will be discussed first, followed by a discussion of the differences introduced by the other methods mentioned above.

a. Horizontal base, case II.—Five men are necessary for the operation of the plotting board, M1904, when using the horizontal base system with case II pointing and the prediction scale and set-forward rule or chart—the plotter, the primary arm setter, the secondary arm setter, the angular travel device (tally dial and tally subdial) operator, and the set-forward rule (or chart) operator.

(1) *Tracking.*—Each arm setter wears a telephone head set connected to the reader at the corresponding observation station. He receives the azimuth of the target as called out

by the reader at the sounding of the TI signal and sets his station arm to that azimuth, repeating the azimuth back to the reader. When his arm is properly set he calls SET. (To reduce confusion in the plotting room, it is often preferable not to have the arm setter repeat the azimuth but to have the reader repeat the hundredths of a degree of azimuth.) When both arm setters have called SET, the plotter places the targ accurately at the intersection of the station arms and marks on the plotting board the position of the plotted point. He then calls or signals CLEAR, upon which the arm setters move their arms away from that part of the board to give the plotter space in which to work. This operation is repeated for each plotted point.

(2) *Determination of rate of angular travel of target.*—When the first plotted point is located, an arm setter swings the gun arm up to the edge of the targ at that point and holds it in this position while the angular travel device operator sets the tally dial and subdial at normal. (At this time the plotter announces the approximate range and the angular travel device operator announces the approximate azimuth to the target from the directing point for use in adjusting all instruments and guns to the approximate position for operation.) When the next plotted point is located and the gun arm swung against the targ held at this point, the angular travel device operator calls out the angular travel reference numbers from the tally dial and subdial for use on the deflection board and again sets the two dials at normal. This operation is repeated for each plotted point and follows immediately after the plotting. Angular travel may be taken between set-forward points, but the results are less accurate due to possible errors in prediction.

(3) *Location of set-forward point.*—After at least two and preferably three plotted points are located, a set-forward point may be located. The plotter estimates the expected course of the target and places the edge of the prediction scale along that line with the zero at the last plotted point. He calls out to the set-forward rule operator the travel of the target during 1 minute (that is, travel during 1 minute when yards travel in 1 minute is the basis used to construct the rule; see pars. 59 to 61, incl.) as is indicated by the plotted

points. The set-forward rule operator calls out the travel during time of flight plus 1 minute. The plotter then marks with the targ the position of the set-forward point along the edge of the prediction scale at the proper distance ahead of the last plotted point. This operation is repeated for each set-forward point and follows immediately after the determination of the rate of angular travel.

(4) *Relocation.*—When the first set-forward point is located, the gun arm is swung against the targ held at that point and the plotter reads the uncorrected range to the set-forward point from the range scale on the gun arm. He then places a small triangle (Δ) around the point as a distinguishing mark to avoid confusion with later plotted points. This operation is repeated for each set-forward point and follows immediately after the location of the set-forward point.

b. Vertical and self-contained bases, case II.—A change to vertical or self-contained base makes a change in the operation of tracking only. All other operations and their sequence are unchanged. The number of men may be reduced by one since only one arm setter is necessary. The variations in procedure are as follows:

The arm setter receives both azimuth and range from the reader. He sets his station arm in azimuth, calls SET, and repeats the range to the plotter. The plotter places his targ at that range along the station arm, marks the position of the plotted point, and calls CLEAR. The arm setter then moves his station arm away as before.

c. Case III pointing.—When using case III pointing the azimuth is used in place of deflection, therefore the rate of angular travel is not necessary. The operation of determining the uncorrected azimuth to the set-forward point is performed immediately after the determination of the uncorrected range. The number of men is unchanged.

(1) *Determination of uncorrected azimuth.*—At the same time that the plotter is determining the uncorrected range to the set-forward point, the angular travel device operator notes the uncorrected azimuth as indicated on the gun arm azimuth scale and subdial. He calls out the azimuth immediately after the plotter calls out the range.

(2) *Location of predicted point.*—If when using case III pointing it is desired to locate the predicted point in addition to the set-forward point, the plotter marks the predicted point with the targ as he calls out the travel during the dead time to the set-forward rule operator. He then proceeds with the location of the set-forward point as before. After the uncorrected firing data for the set-forward point have been determined, the plotter moves the targ to the predicted point and swings the gun arm against the targ. The angular travel device operator then reads the azimuth of the predicted point from the gun arm azimuth scale and subdial.

d. Predicting by set-forward scales.—When predicting by set-forward scales, the set-forward rule (or chart) and its operator are no longer necessary. In this case the plotter locates the set-forward point as described in paragraph 65 and proceeds to the determination of the uncorrected firing data. The predicted point, if desired, may then be located by sliding the set-forward scale along the expected path of the target until the graduation that was opposite the next to last plotted point is opposite the last plotted point, and marking the position of the predicted point opposite the zero of the scale.

SECTION II

MORTAR PLOTTING BOARDS

■ 70. MORTAR PLOTTING BOARDS, M1906 AND M1906 ML.—These boards are similar to the plotting board, M1904, for guns. They are designed particularly for case III pointing which is the method of pointing mortars. The principal change consists of installing a more accurate azimuth indicating device on the mortar arm center. The adjustment, orientation, and operation of these boards are the same as for the gun plotting board described in paragraphs 67 to 69, inclusive.

■ 71. MORTAR PLOTTING BOARD, M1911 (360°).—As its name implies, the form of this board is a full circle. It is made in two semicircular sections. The center of the board is taken to represent that base end station which is farther from the directing point of the battery. In former models of

plotting boards the primary station was represented at the center of the board. In the M1911 board, under ordinary conditions, the secondary station will be the center of the board. The board is designed to be used with any azimuth of base line; any location of the outer station between 800 (1,000 for boards Nos. 1 and 2) and 8,000 yards to the right or left of the center station; and any location of gun between 800 (1,000 for boards Nos. 1 and 2) and 8,000 yards to the right or left of the center station and less than 2,100 yards to the front or rear of the base line. The mortar arm is provided with a sliding range scale by means of which flat range corrections of plus or minus 500 yards may be made from the normal position which is marked 2,000. The center, outer, and mortar arms are graduated for ranges between 300 and 16,000 yards. A detailed description of the board and its operation may be found in Ordnance Department publications, copies of which are issued to batteries equipped with boards of this type.

SECTION III

110° PLOTTING BOARDS, M1915, M1918, AND M3

■ 72. DESCRIPTION.—These boards are for use with all types of fixed seacoast artillery cannon. They provide means for locating the target by either the two-station or the single-station method, for locating and relocating the set-forward point in range and azimuth, and for determining the rate of angular travel when case II pointing is being used. The 110° plotting board, M1918, is practically identical with the M1915 board except that the former is slightly larger and covers longer ranges. The M3 board is similar to the other two, but is a board made for a particular battery and has an azimuth circle and a plotting surface covering the whole seaward field of fire of that battery. Only the M1915 board (fig. 35) will be discussed in detail.

The board is similar in principle to the Whistler-Hearn type of plotting board. It is designed to accommodate the increased ranges of modern cannon and to increase the accuracy of mechanical operation in plotting and relocation.

The board proper is a wooden board supported on a frame on four wrought-iron pipe legs with provisions for approxi-

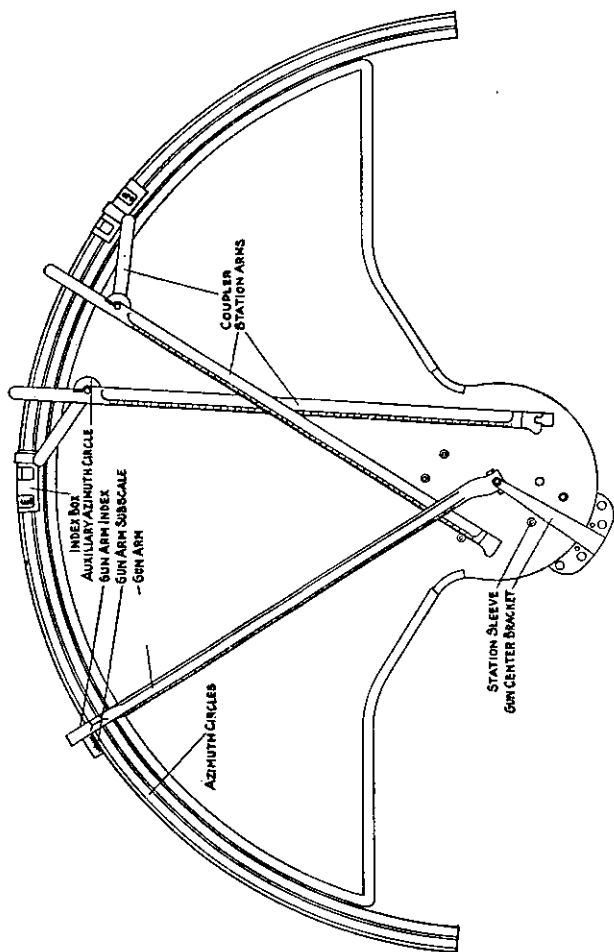

FIGURE 35.—110° plotting board, M1915.

mate leveling. An azimuth circle of about 150° of arc is provided on the periphery of the frame.

On this board the directing point is at the center of the azimuth circle and the gun arm is pivoted in the gun center bracket above this point. Vertical pivoting is also provided to facilitate handling the gun arm when operating the board.

A circular bronze plate called the "station plate" is placed on the board with its center at the center of the azimuth circle. The primary and secondary stations are represented by sleeves placed in the station plate and located in azimuth and distance from the directing point. On this board, the azimuth covered by the azimuth circle are not limited by the azimuth of the base line. Therefore, the azimuth circle may be marked to cover any segment of the circle about the directing point. The azimuth represented by the center line of the board may be used as a reference line in locating the station positions. Positions for auxiliary and emergency stations of the battery may also be included on the board.

The station arms are pivoted in sockets in the sleeves and are furnished with couplers equal in length to the displacement of the stations from the directing point. The couplers are attached to index boxes riding along the azimuth circle and keep the station arms at all times parallel to imaginary auxiliary arms pivoted at the directing point. This arrangement permits the use of the same azimuth scale for all three arms and eliminates the use of a gun arm center, a source of mechanical error on the Whistler-Hearn board.

In order to cover 360° of azimuth, four positions of each observation station are provided in the station plate, and four rows of azimuth scales differing by 90° are marked on the azimuth circle. The quadrants are lettered *A*, *B*, *C*, and *D*; all station positions and the azimuth scale for the same quadrant are marked with the same letter. The principles involved in this arrangement are illustrated in figure 36. In this figure the normal set-up of the board is shown at the left. This is the set-up for quadrant *A* in which the center line of the board represents 180° azimuth (from south). The positions of the station sleeves for this quadrant are shown at $B^1(A)$ and $B^2(A)$. The set-up for which the center line of the board represents 90° azimuth is shown at the right.

If now the figure at the right is revolved clockwise through 90° and placed on the figure at the left, the station sleeves will fall at the positions $B^1 (B)$ and $B^2 (B)$. By pivoting the station arms in the latter positions and by decreasing the readings of the azimuth circle by 90° , the board will duplicate the set-up for quadrant *B*. The same provisions may be made for quadrants *C* and *D*.

When one or more observation stations are located so close to the directing point that the station sleeves cannot be provided without mechanical interference, all four positions for each station so located are put on a center station plug which fits into a square bushing in the station plate. An arrow on the plug pointing to the quadrant letter on the station plate indicates the quadrant position being used. To change quadrants, remove the plug and replace it in the desired position.

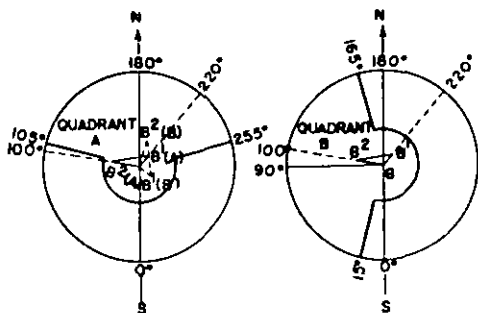

FIGURE 36.—Arrangement of quadrant positions on 110° plotting board.

Azimuths of the station arms are read by means of the index boxes attached to the couplers. Degrees of azimuth are indicated on the azimuth scale; hundredths of a degree are indicated on a subscale on the index box. Two subscales are provided on each index box, one engraved and filled in in black, the other in red. The black subscale is the normal one for use and indicates the azimuth of the imaginary auxiliary arm and, therefore, of the station arm. The red subscale is for use when the target is in such a position that the station arm or coupler covers the black subscale. It indicates

an azimuth 3° greater or less than that of the arm, according to whether it is to the right or to the left of the black subscale looking from the center of the board. The gun arm is provided with a single subscale. The least reading on the subscales is 0.05° . There are four holes in the gun arm index immediately over the four azimuth scales on the azimuth circle. The azimuth scale being used is indicated by placing the index pin in the proper hole.

An auxiliary azimuth circle, graduated in degrees, is riveted to each coupler in such position that when oriented the beveled edge of the station arm will indicate on the auxiliary circle the azimuth of that arm to the nearest degree.

■ 73. ORIENTATION.—The station sleeves are placed and the azimuth scales oriented by Ordnance Department personnel before the board is issued to the using battery. The only orientation necessary at the battery is selection of the proper station arms with their couplers, determination of the quadrant most suitable for the position of the target, placing of the station arms in the proper sleeves for that quadrant, and insertion of the index pin in its proper hole in the gun arm index.

■ 74. OPERATION.—This board has no special device for the determination of angular travel, other plotting room devices having been adapted to the use of azimuths of successive plotted (or set-forward) points in determining the angular travel of the target for case II pointing. Therefore, the operation of the board for case II pointing and the operation for case III pointing are identical and both are similar to that described for the Whistler-Hearn board when using case III pointing. (See par. 69.) For horizontal base tracking with prediction scale and set-forward device, the personnel consists of the plotter, two arm setters, and a set-forward device operator. The azimuth of the set-forward point is read by one of the arm setters. For vertical or for self-contained base tracking or for prediction by set-forward scales, the variations in procedure are the same as for the Whistler-Hearn board. (See par. 69*b* and *d*.)

SECTION IV

PLOTTING AND RELOCATING BOARDS, M1923 (CLOKE)
AND M1

■ 75. DESCRIPTION.—*a.* The plotting and relocating board, M1923 (see fig. 37), is for use with all types of mobile seacoast artillery. It provides means for performing the same operations as does the 110° board.

b. The 110° board is entirely satisfactory for cannon on fixed emplacements but has no provisions for readily changing the position finding set-up. Since the set-up of a mobile battery is different for each position occupied, a suitable plotting board for mobile seacoast artillery must provide means for readily setting up and as readily changing any selected arrangement of observation stations, directing point, and field of fire within wide limits. The Cloke board provides these means together with increased accuracy and range over the Whistler-Hearn board. The Cloke board also provides means for relocation of the set-forward point from any point in the vicinity of the directing point.

c. The Cloke board is wooden with an azimuth circle of 188° of arc along the periphery. The azimuth scale is marked on metal strips that fit in a slot in the azimuth circle and may be readily removed and replaced. Markings for both mils and degrees are provided.

d. Two arms, one referred to as the plotting arm and the other the relocating arm, are pivoted at the center of the azimuth circle. The arms are set in azimuths by means of subscales at their outer ends similar to those on the 110° board. The least readings of the subscales are 1 mil and 0.05°. Each arm is provided with range graduations on its reading edge and with four sets of removable range scales so marked that the scale of the board may be made any one of the following: 300, 600, 750, or 1,500 yards to the inch.

e. The base line is represented on the platen, a movable plate pivoted to a slide which fits over the plotting arm. The platen pivot remains coincident with the reading edge of the plotting arm and coincides with the center of the azimuth circle when the slide is pulled against its stop at the inner end of the plotting arm. A clamp on the platen, when

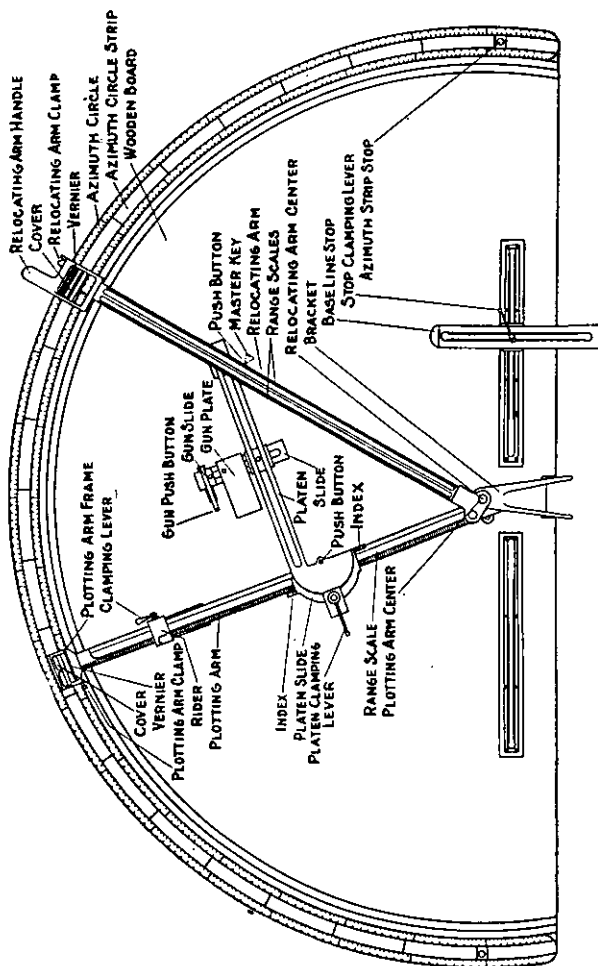

FIGURE 37.—Plotting and relocating board, M1923 (Clove).

tightened, prevents rotation of the platen about its pivot. One observation station is represented by a push button at the platen pivot. The other station is represented by a push button that is placed in the master key. The master key is carried on a slide on the platen and may be moved toward or away from the platen pivot. There is no mechanical connection between the platen and the relocating arm.

f. The directing point is represented by the gun push button which is fastened to the platen by a double slide, allowing movement of the gun push button either parallel to or perpendicular to the platen. When it is desired to relocate the set-forward point from more than one point—for instance, from each gun of the battery—a gun plate may be attached to the platen and the positions of the guns may be located on this plate. Figures 37 and 39 show both the gun push button and the gun plate in position. Ordinarily only one of these parts is attached when the board is used.

g. The Cloke board solves mechanically the same mathematical problem that the Whistler-Hearn or the 110° board does and uses the same observation data in its solution, but its method of solution differs considerably. On the Whistler-Hearn board the azimuths are set from the center of the circle outward and the position of the target moves about the fixed base line; on the Cloke board the azimuths are set from the circle inward to the center, and the base line, moving parallel to itself, moves about the fixed position of the target at the center of the circle. Figure 38 shows the relation between the two boards for a typical set-up. The arrows indicate the direction in which azimuths are set on the two boards. It may be seen from the figure that the arms of the Cloke board correspond to extensions of the arms of the Whistler-Hearn board. With these extensions the arms could be set at the azimuths received from the observation stations as readily by the lower half of the azimuth circle, if properly marked, as by the upper half. When the target is tracked on the Whistler-Hearn board the angles at B^1 and B^2 between the station arms and the base line change, but the position of the base line with respect to the azimuth circle remains fixed. The same condition applies on the Cloke board; provision is made for changing the angles at B^1 and

B^2 while the base line is maintained parallel to its original position. When orienting the board an orienting position for the platen is established. Before each TI bell, the platen is brought to this orienting position and the platen clamp is loosened to allow movement of the plotting arm and the platen slide without rotation of the platen. After the plotting arm is set to the new azimuth, the platen clamp is tightened and the platen is slid along the arm to its position for plotting.

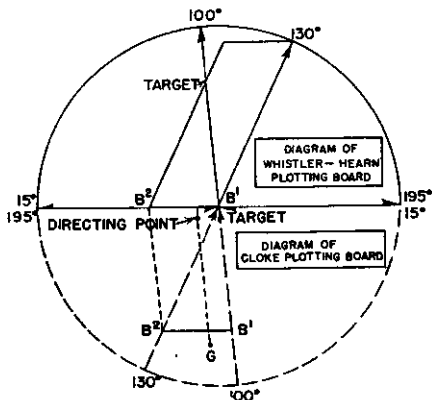

FIGURE 38.—Relation between Whistler-Hearn and Cloke plotting boards.

h. On both boards the position of the target is indicated by the intersection of the arms. On the Whistler-Hearn board that position is plotted, and its relative motion about the fixed directing point is used to determine the firing data. On the Cloke board the movement of the directing point is plotted, and its relative motion about the target is used to determine the firing data. Since the same target and the same directing point are involved, the relative motion is the same on both boards; if the target is moving clockwise on the Whistler-Hearn board, the directing point on the Cloke board will also move clockwise about the target. Therefore, the two sets of firing data will be identical.

i. The method of determining the proper position along the plotting arm at which to stop the platen, when plotting, depends on the method of target location used, two-station or single-station. In the two-station method, the arms are

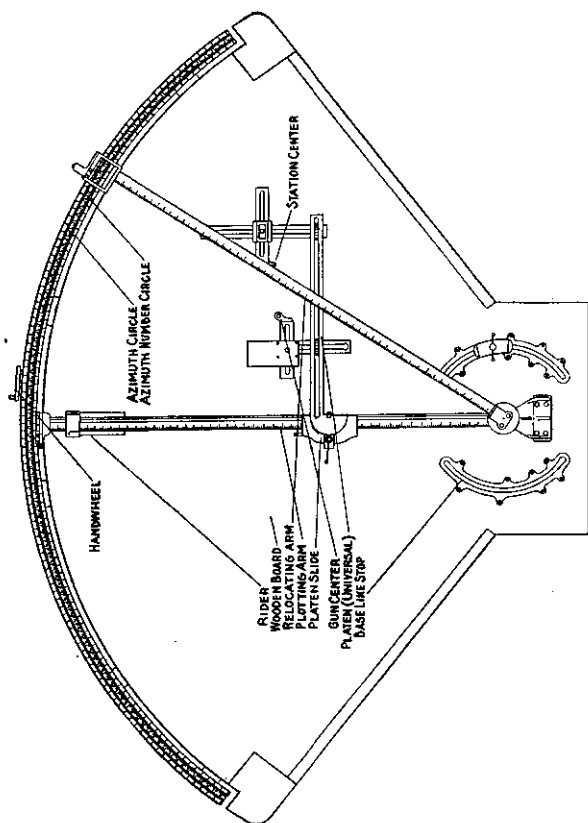

FIGURE 39.—Plotting and relocating board, M1.

set to the azimuths received from their respective stations, and the platen is moved out until the master key touches the relocating arm; in the single-station method, the plotting arm is set to the azimuth received from the observation

station, and the platen is moved out until the range is indicated on that arm by the index on the platen slide.

j. The plotting and relocating board M1 (fig. 39) is similar in construction and operation to the Cloke board. The principal differences are in the construction of the azimuth scale and the base line stop. The azimuth scale is in degrees only, and the readings are marked on an endless chain which can be adjusted by turning a handwheel to put any desired azimuth reading, from 0° to 360° , at the center of the arc; the arc subtended by the azimuth circle is about 120° . The base line stop has been redesigned to facilitate orientation. There are four sets of scales for the plotting and relocating arms as follows:

<i>Scale (yards per inch)</i>	<i>Maximum range (yards)</i>
200 -----	12, 800
400 -----	25, 600
800 -----	51, 200
1, 000 -----	64, 000

■ 76. ORIENTATION.—*a. Base line and azimuth circle.*—From figure 38 it may be seen that in order to duplicate on the Cloke board the triangle shown on the Whistler-Hearn board the two base lines must be parallel. The same relation may be shown when the base line does not pass through the center of the azimuth circle, for example, on the 110° board. It follows from this that the operation of orienting consists of the same problem on the Cloke board as on all other plotting boards, namely, placing the base line in its proper angular relation with respect to any selected radius of the azimuth circle. There is, however, an additional step required in orienting the Cloke board; that is, the establishment of an orienting position at which the platen may be readily reoriented during plotting.

The first consideration is the selection of the azimuths to be covered by the board. The usual procedure is to put the azimuth of the center of the field of fire at or near the center line of the board. This may be done by sliding the metal strips of the azimuth scale around the circle until the desired azimuth marking is at the center of the arc. In case it is desired to set up the board for the simultaneous use of

mils and degrees there is one precaution to be observed. At the reference line (zero) of any azimuth circle and at each multiple of 9° of azimuth the full mil and degree graduations coincide. On the Cloke board those points are indicated on the azimuth circle by longer lines that are at other points. Azimuths that are multiples of 9° should be set at the longer lines.

The next step is the selection of positions to represent the observation stations. On the Cloke board the positions of the observation stations, such as B^1 and B^2 , and of G are represented on the platen as previously explained. The board may be set up for operation with the platen and the relocating arm on either side of the plotting arm; either station may be located at the platen pivot. As a general rule the more convenient arrangement is to put at the platen pivot the station more distant from the directing point. There are, however, practical considerations which occasionally dictate the choice of positions. Sometimes the position finding set-up is such that the mechanical construction of the board limits the choice of positions in orienting. If the orientation is prevented by mechanical interference, reverse the platen and station positions and reorient. A little experience in the use of the board will be of assistance in selecting the arrangement most convenient for orienting and plotting.

(1) *Ordinary orientation* (by azimuth and length of base line).—Because of its flexibility the Cloke board may be oriented in several ways. The ordinary method of orientation is by use of the azimuth and length of the base line. This method should be used whenever possible because it is more accurate than either of the other methods. The method is illustrated in figure 40. In that set-up, the platen pivot has been selected to represent B^2 and the master key to represent B^1 . The azimuth of the base line is 107° , and its length is 6,000 yards. The procedure is as follows:

(a) Release the platen clamp and slide the platen along the plotting arm until the slide touches its stop at the inner end of the plotting arm. This brings the platen pivot over the center of the azimuth circle.

NOTE.—The azimuth at which the plotting arm is set is immaterial.

(b) Set the relocating arm at the azimuth of the base line and clamp it. According to the general rule, the azimuth set should be that from the outside to the center of the circle, or from the station represented by the master key to the station represented by the platen pivot—in this case from B^1 to B^2 .

(c) By means of the relocating arm, set the master key at a distance from the platen pivot equal to the length of the base line.

NOTE.—This may be done either before or after the relocating arm is set at the azimuth of the base line.

(d) Holding the platen slide against its stop, swing the platen about its pivot until the edge of the master key is against the reading edge of the relocating arm and tighten the platen clamp. The platen is now oriented.

(e) With the platen slide still against its stop, bring the base line stop against the edge of the platen and clamp the base line stop. This establishes the orienting position for the platen for use in plotting.

(2) *Orientation by datum point.*—This method is of particular value in orienting a board for an emergency set-up in which the azimuth and length of the emergency base line are not known. By this method the platen may be oriented for any two observation stations from each of which the azimuth and range to a point in the field of fire are known. This method also is illustrated in figure 40. The procedure is as follows:

(a) Set and clamp each arm at the azimuth from the station it represents to the datum point.

(b) Release the platen clamp and the slide holding the master key and slide the platen along the plotting arm until the index on the slide is set at the range from the station represented by the platen pivot (in this case B^2) to the datum point.

(c) Holding the platen slide at that range, swing the platen about its pivot and move the master key along the platen until the master key touches the relocating arm at the range from the station it represents (in this case B^1) to the datum point. Clamp the platen to the slide and the master key to the platen. The platen is now oriented.

(d) Slide the platen along the plotting arm until the slide touches its stop at the center of the circle; bring the base line stop against the edge of the platen and clamp the base line stop. This establishes the orienting position for use in plotting.

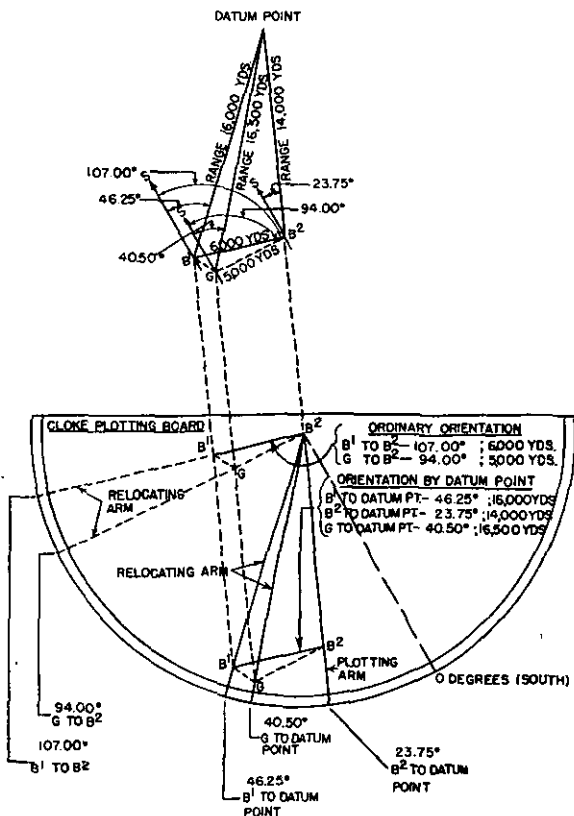

FIGURE 40.—Orientation of Cloke board, ordinary and datum point methods.

(3) *Orientation by equilateral triangle.*—This method may be used when, for ease in plotting, it is desired to represent a particular station at the platen pivot, and the azimuth from the station represented by the master key to the station represented by the platen pivot cannot be set on the board. For instance, if in the situation shown in figure 40, B^1 were at the platen pivot and B^2 at the master key, the azimuth for use in the ordinary method of orientation would be 287.00° . This azimuth is not included in the semicircle on the board. This method is illustrated in figure 41. This is the original set-up with the platen and the relocating arm on the opposite side of the plotting arm, which places B^1 at the platen pivot and B^2 at the master key. The azimuth of the perpendicular to the base line is $107.00^\circ - 90.00^\circ = 17.00^\circ$. The procedure is as follows:

(a) Set and clamp the arms as follows:

1. The arm on the right to the azimuth of the perpendicular -30° .
2. The arm on the left to the azimuth of the perpendicular $+30^\circ$.

(b) Release the platen clamp and the slide holding the master key and slide the platen along the plotting arm until the index on the slide is set at the range equal to the length of the base line.

(c) Holding the platen slide at that range, swing the platen about its pivot and move the master key along the platen until the master key touches the relocating arm at the range equal to the length of the base line. Clamp the platen to the slide and the master key to the platen. The platen is now oriented.

(d) Slide the platen along the plotting arm until the slide touches its stop at the center of the circle; bring the base line stop against the edge of the platen and clamp the base line stop.

b. *Directing point.*—After the base line has been oriented, the position of the directing point must be located. The orientation of the directing point consists of placing it in its proper relation to the observation stations; that is, placing

the gun push button on the platen in its proper relation to the platen pivot and the master key. If the azimuth and distance from the directing point to the station represented by the platen pivot are known and if that azimuth can be set on the azimuth circle, the position of the gun push button may be found in the same manner as that of the master key in ordinary orientation. (See *a*(1) above.) When this

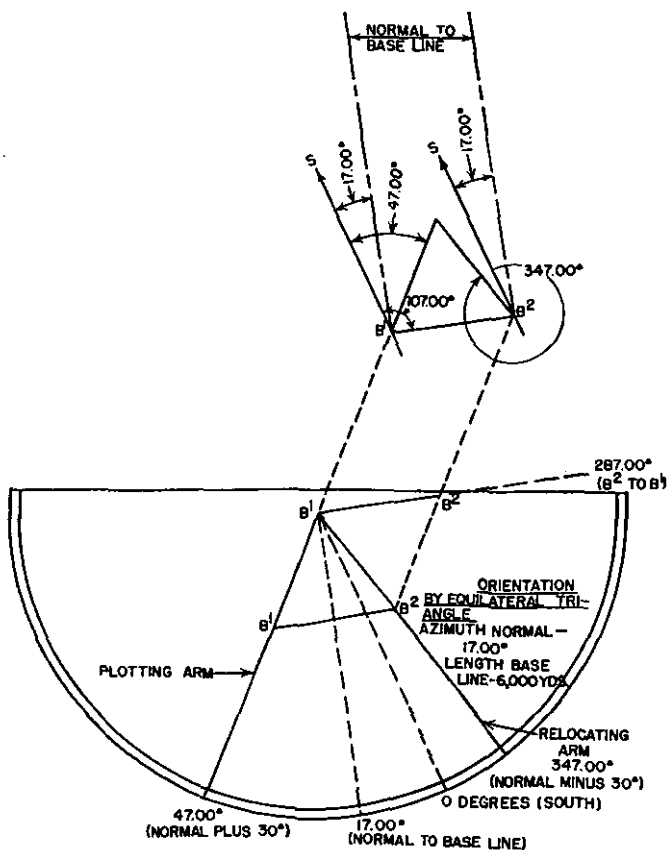

FIGURE 41.—Orientation of Cloke board, equilateral triangle method.

method is used, the platen must be held in its orienting position against the slide stop and the base line stop. This method may be used regardless of the method used in orienting the base line. An alternative method of orientation is the datum point method described in *a*(2) above, using the azimuth and range from the directing point to the datum point. When the gun plate is used and the location of all guns of the battery is desired, their positions on the gun plate may be located in the same manner as that described for the location of the gun push button.

c. Orientation for single-station position finding.—When the single-station method of position finding is used, put that station at the platen pivot and *G* at the gun push button and proceed as for orientation of a base line. (See *a* above.)

■ 77. OPERATION.—Since on this board the rate of angular travel is determined by azimuths as on the 110° board, the operation of the board is the same for case II and for case III pointing. It is similar to that described for the Whistler-Hearn board when using case III pointing (see par. 69) except in the operation of tracking. For horizontal base tracking with prediction scale and set-forward device, the personnel consists of a plotter, two arm setters, a platen operator, and a set-forward device operator. The azimuth and range to the set-forward point are indicated by use of the relocating arm. For prediction by set-forward scales, the variations in procedure are the same as for the Whistler-Hearn board (par. 69*d*).

a. Horizontal base tracking.—Each arm setter sets his station arm to the azimuth received from the reader and calls SET. While the plotting arm is being set, the platen operator keeps the platen at the orienting position against the slide stop and the base line stop with the platen clamp loosened. When both arm setters have called SET, the platen operator tightens the platen clamp and slides the platen along the plotting arm until the master key touches the relocating arm. He may start this operation as soon as the plotting arm is set, but he may not complete it until the relocating arm is set. The plotter marks the position of the plotted point on the board by pressing the gun push button and calls

CLEAR. The platen operator releases the platen clamp and withdraws the platen to the orienting position. This procedure is repeated for each plotted point.

b. Vertical and self-contained bases.—A change to vertical or self-contained base makes a change in tracking only. All other operations and their sequence are unchanged. The number of men may be reduced by one since only one arm setter is necessary. The variations in procedure are as follows:

The arm setter sets the plotting arm to the azimuth received from the reader, calls SET, and repeats the range to the platen operator. The platen operator slides the oriented platen out until that range is indicated on the plotting arm by the index on the platen slide and calls SET. The plotter then marks the position of the plotted point as before.

c. Relocation for more than one point.—When using the Whistler-Hearn or the 110° board, the set-forward point may be relocated with respect to the directing point only. If the guns are so widely separated that displacement corrections are necessary, difference charts (see pars. 26 to 37, incl.) must be used. The Cloke board, however, permits the relocation of the set-forward point from all guns of the battery by the use of the gun plate and a special method called "offset plotting." The gun plate is attached to the platen and the positions of the guns marked on the gun plate as explained in paragraph 76*b*. To avoid predicting for each separate gun position the procedure is altered slightly. The plotted points are marked by the push button at the platen pivot instead of by the gun push button, and predictions are made for that station instead of for the directing point. The oriented platen is then moved out until the platen pivot is over its set-forward point, and the set-forward point for each gun is indicated by the gun positions on the gun plate. The variations in the procedure are as follows:

When the platen operator calls SET, the plotter marks the position of the platen pivot on the board. After he locates the set-forward point he places the targ at that point and the arm setter brings the plotting arm against the targ. The plotter then slides the rider (shown in fig. 37) along the plotting arm until the finder on the rider touches the targ,

and clamps the rider to the plotting arm. The platen operator, having withdrawn the platen to its orienting position, tightens the platen clamp and brings the oriented platen against the rider. (This places the platen pivot over its set-forward point.) The plotter places the targ at each gun position in turn and the arm setter brings the relocating arm against the targ. The plotter then reads the range and the arm setter reads the azimuth to each set-forward point.

CHAPTER 11

RANGE CORRECTION DEVICES

	Paragraphs
SECTION I. General.....	78-79
II. Wind component indicator.....	80-82
III. Range correction board M1.....	83-86
IV. Other models of range correction boards.....	87-90
V. Percentage corrector M1.....	91-92

SECTION I

GENERAL

■ 78. FUNCTIONS.—The functions of range correction devices are to provide means for determining the range corrections due to nonstandard ballistic conditions, to apply those corrections to the range to the set-forward point, apply range adjustment corrections as a result of observation of fire, and to transform the corrected range into suitable data for pointing the guns in elevation.

The necessity for ballistic corrections was discussed in paragraph 23. The corrections are determined by a range correction board supplemented by the wind component indicator. This board presents data from the firing tables in graphical form and in such manner that the algebraic sum of the corrections may be determined readily and as readily changed to meet the changing conditions which arise.

The adjustment corrections are determined after observation of fire and after operation of the devices comprising the spotting system of the battery. The necessity for these corrections and an explanation of the spotting devices are discussed in chapter 13. The adjustment correction is determined in the same units as the ballistic correction, that is, percentage of the range.

The ballistic and adjustment corrections are applied to the range to the set-forward point on a percentage corrector, which also transforms the corrected range into suitable firing data when necessary. There are two occasions when transformation is necessary. The more frequent

occasion is when the pointing device on the gun is marked in angular units (either mils or degrees) instead of range. The other occasion is when the pointing device is marked in units of range but the range elevation relation used in marking is different from the range elevation relation that should be used for the particular combination of gun, powder charge, and projectile.

■ 79. METEOROLOGICAL MESSAGE.—*a. Description.*—(1) Information as to variations from standard of atmospheric conditions are contained in the meteorological message. Data contained in this message are determined by the personnel of the meteorological station and supplied to the using battery hourly during any period when firing is expected. The meteorological message consists of groups of symbols arranged in codified form. The message starts with the code designation of the sending station, repeated, consisting of three letters the first of which is always the letter M; the other two are the identifying letters of the station. This is followed by several number groups. The first number group has five digits and the remaining groups have seven digits each. The five-digit group has the following significance: The first digit is either the figure 2 or the figure 3 denoting the type of the message. The figure 2 denotes that the message is of the type suitable for high angle fire; the figure 3, that it is of the type suitable for low angle fire. The second and third digits of the group give, in hundreds of feet, the altitude of the meteorological datum plane (m. d. p.) above sea level. The fourth and fifth digits give the temperature at the m. d. p. in degrees Fahrenheit. The seven-digit groups are similar in type and significance except that each refers to a particular altitude above m. d. p. The first digit of each group designates that altitude zone. The second and third digits indicate the direction from which the ballistic wind is blowing in hundreds of mils clockwise from north. The fourth and fifth digits give the speed of the ballistic wind in miles per hour. The last two digits give the ballistic density in percent of normal.

(2) The following is a typical meteorological message:

MFMMFM

30278
 0241699
 1231799
 2221899
 3211800
 4211900
 5202001
 6202001
 7192102
 8192102
 9192102
 0182103
 1182203

The message may be translated as follows:

Meteorological message from station FM for low angle
 fire.

Altitude of m. d. p.—200 feet above sea level.

Temperature at m. d. p.—78° F.

Altitude zone	Upper limit of altitude zone in feet	Direction from which ballistic wind is blowing in mils clockwise from north	Speed of ballistic wind in m. p. h.	Density in percent of normal
0 (surface).....	0	2,400	16	99
1.....	600	2,300	17	99
2.....	1,500	2,200	18	99
3.....	3,000	2,100	18	100
4.....	4,500	2,100	19	100
5.....	6,000	2,000	20	101
6.....	9,000	2,000	20	101
7.....	12,000	1,900	21	102
8.....	15,000	1,900	21	102
9.....	18,000	1,900	21	102
10.....	24,000	1,800	21	103
11.....	30,000	1,800	22	103

b. Application.—(1) The data taken from a meteorological message for a selected firing will be that contained in the five-digit group and one of the seven-digit groups. The seven-digit groups contain data as to the ballistic wind and the ballistic density. The ballistic wind is a fictitious wind, constant in magnitude and direction, which would have the same total effect on the projectile during its flight as the true winds of varying magnitude and direction that are actually encountered. It is computed from observations taken on the true winds at different altitudes above the m. d. p. Likewise, the ballistic density is a fictitious constant density which would have the same total effect as the various true densities and is computed from observations and formulas. Each seven-digit group contains the data for the ballistic wind and ballistic density for one altitude zone only. The particular seven-digit group appropriate for use is that group of which the altitude above the m. d. p. is nearest to and not less than the maximum ordinate of the trajectory, for the range to the target, as measured from the battery level. When the battery and the m. d. p. are not at the same altitude above sea level, the temperature and the ballistic density must be corrected for the difference in altitude. The data concerning the ballistic wind are taken without change. Formulas for the correction of temperature and ballistic density may be found in all firing tables. The data from the meteorological message are used, part on the wind component indicator and part on the range correction board as will be discussed later.

(2) The following example shows the application of a meteorological message to a selected firing:

A battery of 12-inch guns, M1895, on barbette carriage, M1917, using 975-pound projectile (Firing Tables 12-F-3), is firing at a target at a range of 18,400 yards. The altitude of the battery is 20 feet above sea level. What data from the meteorological message given in *a* above should be used? What is the corrected data?

Solution: From part 2, table A, Firing Tables 12-F-3, the maximum ordinate for a range of 18,400 yards is found to be 4,405 feet. Therefore, data for the fourth altitude zone

(upper limit 4,500 feet) should be used. The complete data from the message are—

Altitude m. d. p.—200 feet.

Temperature at m. d. p.—78 degrees F.

Ballistic wind—2,100 mils from north, at 19 m. p. h.

Ballistic density—100 percent.

The corrections for temperature and ballistic density should be as follows:

Temperature—an increase of $\frac{1}{5}^{\circ}$ for each hundred feet decrease in altitude or $\frac{1}{5}^{\circ} \times 1.8 = +0.36^{\circ}$.

Ballistic density—an increase of 0.3 percent for each hundred feet decrease in altitude or $0.3 \times 1.8 = +0.54$ percent.

The complete corrected data are—

Temperature—78° (nearest degree).

Ballistic wind—2,100 mils from north, at 19 m. p. h.

Ballistic density—101 percent (nearest percent).

SECTION II

WIND COMPONENT INDICATOR

■ 80. WIND CORRECTION PROBLEM.—In making corrections for the effect of the wind, the ballistic wind is resolved into two components—one in the plane of fire, affecting range; and the other perpendicular to the plane of fire, affecting direction. The problem is illustrated by the sketch at the top of figure 42 where a wind of magnitude GW is blowing toward W at an angle WGR with the plane of fire. GR represents the magnitude of the range component and RW the magnitude of the deflection component.

■ 81. DESCRIPTION.—The wind component indicator (fig. 42) is a device for mechanically resolving the ballistic wind into its range and deflection components. It consists of a circular plate (P) surrounded by an azimuth circle, and an arm (A), called the target arm, pivoted at the center and riding above both. The plate is stationary; it is engraved with cross section lines spaced in units of miles per hour but marked in wind reference numbers with 50 as the normal. (See par. 55.) An index (K) at the bottom of the plate is used to set the wind azimuth. The azimuth circle is movable; it is en-

graved with two azimuth scales, an inner scale in mils and an outer scale in degrees. The zeros of the two scales are 180° apart. This arrangement was chosen to permit the use of wind azimuths in mils from north and target azimuths in

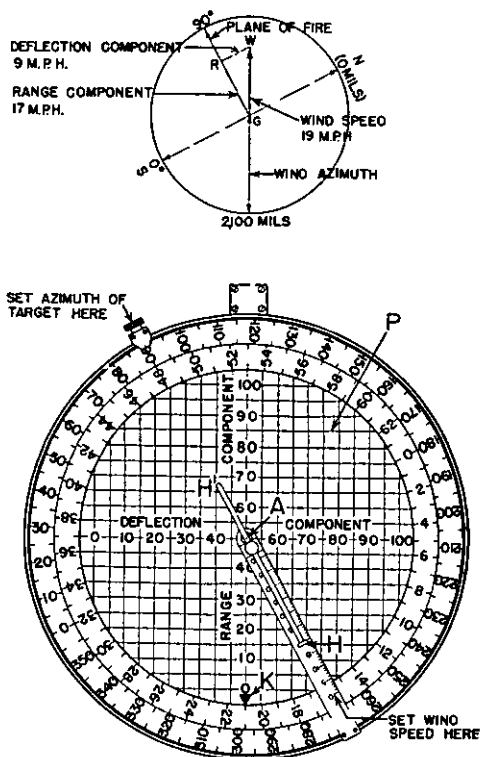

FIGURE 42.—Wind component indicator.

degrees from south. The target arm is engraved with a linear scale graduated in miles per hour. By means of this scale the setting end (H) of the pointer carried by the arm may be set so that its reading end (H') is at a distance from the

center of the circle equal to the speed of the ballistic wind. If, after the speed of the ballistic wind is set on this scale, the azimuth circle is set by means of the index (*K*) on the plate and the mil scale, to the azimuth from which the ballistic wind is blowing, and the target arm is set to the azimuth of the set-forward point by means of the index (*C*) on the arm and the degree scale, the situation shown in the sketch at the top of figure 42 will be duplicated on the indicator except that the triangle *GWR* will be turned over and the lines *GW* and *GR* will have exchanged places. This arrangement was chosen to permit reading the values of the effects from the fixed plate. A single instrument serves for both range and deflection computations. The range component may be read from the vertical scale, and the deflection component from the horizontal scale, on the plate. It will be noted that readings less than 50 indicate a wind retarding the projectile or blowing it to the right, and that readings greater than 50 indicate a wind accelerating the projectile or blowing it to the left.

■ 82. ORIENTATION AND OPERATION.—The operator sets the pointer to the wind velocity and the azimuth circle to the azimuth from which the wind is blowing, using the mil scale. These settings are obtained from the meteorological message. He keeps the target arm set to the uncorrected azimuth of the set-forward point as called out by the plotter, using the degree scale and the target arm index for the setting. The range component reference number is used on the range correction board and the deflection component reference number on the deflection board.

NOTE.—When the firing battery is using azimuths of the target with zero north, the instrument if operated normally will give wind effects in the wrong directions. If the azimuth of the set-forward point is in mils the correct effects will be obtained by setting the index of the target arm on the mil scale. If the azimuth is in degrees, the correct effect will be obtained by setting the wind azimuth at the top of the plate instead of at (*K*) and setting target azimuths as usual.

The wind component indicator is not issued to batteries equipped with the deflection board M1. In batteries so equipped the wind reference numbers are read from the wind component indicator on the deflection board.

SECTION III

RANGE CORRECTION BOARD M1

■ 83. DESCRIPTION.—*a.* A range correction board (fig. 43) is a mechanical device for determining the algebraic sum of the range corrections due to prevailing nonstandard ballistic conditions. This correction is called the ballistic correction. The M1 board is typical and since it is the present standard range correction board will be explained in detail.

b. The board consists of four major parts: a chart bearing curves which indicate the individual corrections; a ruler that makes the algebraic addition (see par. 14, appendix II); a scale which indicates the ballistic correction; and a mount for the whole.

(1) The chart has a set of curves for each nonstandard condition for which correction is made. Each set consists of a series of curves, one curve for the standard condition (the normal of the set) and one for each unit of variation from standard that it is desired to show. The curves are plotted by rectangular coordinates with range as ordinates and range effects in percent of the range as abscissas. The range and other pertinent firing table data are listed along the sides of the chart. The data for plotting are taken from the firing tables. A chart must be constructed for each combination of gun, powder charge, and projectile. Further details on the construction of the chart may be found in appendix II. The M1 board utilizes charts for the type of armament being used. These charts are mounted on rollers so that the desired chart may be placed in position for use. The charts on this board have curves for muzzle velocity, atmospheric density, height of site (or tide), ballistic wind, weight of projectile, elasticity, and rotation of the earth.

NOTE.—The effect of rotation of the earth, in both range and direction, varies with the latitude of the firing position, the azimuth of the plane of fire, and the elevation (or range). Since only two variables may be shown on one set of curves and it was considered impracticable to furnish sufficient curves for all situations in a readily usable form, one of those variables had to be eliminated. The variable causing the least changes in the effect is the latitude. It was therefore decided to construct the curves for a mean latitude of 30° for use within the United States. Each curve is plotted for a selected azimuth of the target.

(2) The correction ruler consists of a strip of metal with two raised bars extending across it. The upper bar is fixed to the ruler; the lower bar is movable and may be slid across the ruler in either direction. A system of gears actuated by a knob is provided for sliding the movable bar. Mounted on the two bars is a slide for each set of curves on the chart. Each slide has a double-action clamp by which it may be clamped to either of the two bars. When the clamp is moved to the position *M*, the slide is clamped to and moves with the movable bar; when the clamp is moved to the position *S* the slide is clamped to the fixed bar and the movable bar may be moved independently of the slide. The ruler when mounted for operation is above the chart and parallel to the range lines.

(3) The correction scale is engraved on the upper edge of a plate attached to the ruler. It is graduated in reference numbers of percent of the range with 300 as normal. (See par. 56.) An index attached to the movable bar indicates the correction. On the lower edge of the plate is an auxiliary scale similarly graduated by which the plate may be moved to offset the normal of the correction scale if desired. A fixed index below the plate registers on the auxiliary scale. Arbitrary corrections in terms of percent of the range may be added algebraically to the ballistic correction by these means.

(4) The mount is a metal case that contains the charts and rollers. The ruler is fixed to the top of the case by clamps allowing a slight movement of the ruler for adjustment.

c. When a slide is moved from its normal curve to the intersection of the proper range line and the curve representing the nonstandard condition that prevails, the index on the movable bar is displaced in the same direction and by the same amount. By setting each slide in turn, the algebraic sum of the corrections is indicated on the correction scale.

d. The board is designed for continuous operation throughout the firing. As the range to the set-forward point changes, the chart is moved to keep the proper range line under the ruler. Each slide may then be moved in turn to bring it

to the intersection of the curve with the new range line. This operation changes the correction by the amount of change due to the change in range and has the same effect as though the slides were all brought back to normal and reset at the proper curves. Changes in any nonstandard condition, such as a change in the wind reference number due to a change in the azimuth of the target, may be made in the same way.

■ 84. ADJUSTMENT.—*a.* The mechanical adjustments of the board are the adjustment of the chart and the adjustment of the correction ruler. The chart must be adjusted on its rollers so that the normal lines on each set of curves will not be displaced laterally as the chart is moved past the ruler. The correction ruler must be placed parallel to the horizontal range lines on the chart and clamped in that position. These adjustments may be tested as follows:

Set the slides at their normal correction curves and move the chart back and forth on the rollers. The normal curves, which are straight lines, should remain under the indices of the slides for all positions of the chart.

b. A further adjustment must be made prior to the operation of the board. This adjustment consists of setting the index on the movable bar at the correction on the correction scale that is the algebraic sum of the corrections indicated by the slides. The easiest way to do this is to set all slides at their normal curves and the index on the movable bar at normal (300) on the correction scale. This setting will be referred to hereafter as the initial setting. If it is desired to use the auxiliary scale it also must be set at normal.

■ 85. OPERATION.—*a.* The operator of the board turns the roller handle until the appropriate chart for the firing appears under the correction ruler. He adjusts the ruler and tests the adjustment of the chart making any adjustments found necessary. He makes the initial setting of the board and turns all slide clamps to the position *S* on the slide. He ascertains the proper data as to nonstandard conditions and records with chalk in a convenient place in the space provided near the top of the board the necessary data to

indicate the curves representing those nonstandard conditions. He obtains these data as follows:

- (1) Muzzle velocity, in foot-seconds, from the range officer.
- (2) Atmospheric density, in percent of normal density, from the meteorological message (corrected for difference in elevation).
- (3) Height of site or tide, in feet, from the range officer and the tide station.
- (4) Ballistic wind, in wind reference numbers, from the wind component indicator.
- (5) Weight of projectile, in pounds, from the range officer (who gets the average weight from the battery executive).
- (6) Elasticity, in degrees Fahrenheit, from the meteorological message (corrected for difference in elevation) or from a thermometer at the battery.
- (7) Rotation of the earth, in degrees, from the plotter. (This setting is the azimuth to the set-forward point.)

b. When a range is announced by the plotter, the operator moves the chart to bring that range line under the correction ruler and sets each slide in turn to the proper curve. A slide is set by moving the clamp to the position *M*, operating the correction knob on the ruler until the slide is opposite the proper correction curve, and moving the clamp back to *S*. After all the slides are set he calls out to the operator of the percentage corrector the ballistic correction indicated on the correction scale. Thereafter he keeps the chart set at the proper range line and each slide set at its proper curve. He notes any change of the wind reference number on the wind component indicator, and of the azimuth of the set-forward point, changes the record at the top of the board to indicate the new wind and rotation curves, and adjusts the setting of the slides to those curves. He announces a new ballistic correction whenever it changes by one unit ($\frac{1}{10}$ of 1 percent of the range).

c. In mortar and howitzer fire, the operator of the board must anticipate any change in zones and set up the board for the new zone in time to have a ballistic correction ready when the new zone is announced. The muzzle velocity to be used in the new zone will be furnished by the range officer.

■ 86. ACCURACY TESTS.—Several sets of test points, each set on a selected range line, are indicated on the charts and the true algebraic sums of the corrections are shown at the side of the chart. These points may be used to check the mechanical accuracy of the board and the accuracy of the operator. The accuracy of the board may be checked also by data taken from the firing tables. For example, assume that the chart for 16-inch guns, M1919 MI, firing 2,100-pound A. P. projectile, fuze with B. D. fuze, Mark X, full charge, normal muzzle velocity of 2,750 f/s (Firing Tables 16-B-1), is to be checked for a target at 24,000 yards range and at azimuth 333° from south. The firing position is at 40° north latitude. The prevailing nonstandard conditions and the proper range corrections as taken from Firing Tables 16-B-1 are as follows:

Nonstandard conditions	Corrections	
	Yards	Percent
Muzzle velocity, -30 f/s.....	+403	+1.68
Air density, 97 percent.....	-237	-.99
Battery above mean low water, 100 feet.....		
Height of tide, 10 feet.....		
Target below gun, 90 feet.....	-85	-.35
Wind reference number, 70.....	-135	-.56
Weight of projectile, 2,121 pounds.....	+14	+.06
Temperature (elasticity) of air, 50° F.....	-31	-.13
Rotation of the earth.....	-60	-.25
Total correction.....	-131	-0.54

The algebraic sum of the range corrections is -0.54 percent. The range correction in reference numbers that the board should indicate for the same nonstandard conditions is $300 - 5 = 295$.

SECTION IV

OTHER MODELS OF RANGE CORRECTION BOARDS

■ 87. GENERAL.—There are three other models of the range correction boards that have been issued in the past and which may be found in the service. In design and operation they

are all similar to the M1 board with a few minor exceptions as noted in paragraphs 88 to 90, inclusive.

■ 88. PRATT RANGE CORRECTION BOARD, M1905 (MODIFIED).—On the Pratt board the chart is fixed and the correction ruler is moved along the chart as the range changes. Markers are provided near the top of the board for use in indicating the proper curves to use in determining corrections. The board has been modified to indicate range corrections in percent of the range, but the movement of the index that registers on the correction scale is one-half that of the slides. Therefore the correction scale should be graduated to twice the scale of the chart.

■ 89. RANGE CORRECTION BOARD, M1923.—This board is a development of the Pratt board. It is the first model of range correction board on which the chart is carried on rollers. On some boards the gearing has been modified so that the movement of the correction pointer is equal to that of the slides; on others this modification has not been made. The relation will be disclosed by an inspection of the board.

■ 90. MODIFIED RANGE CORRECTION BOARD, M1923.—This board is the predecessor of and is very similar to the M1 board.

SECTION V

PERCENTAGE CORRECTOR M1

■ 91. DESCRIPTION.—*a.* The percentage corrector M1 (fig. 44) is a device for applying the ballistic and adjustment corrections to the uncorrected range to the set-forward point and for transforming the corrected range, when necessary, to the corresponding elevation or the corresponding range in those units with which the pointing device on the gun is marked. The application of the corrections is made by two correction scales similar to those on the range correction board, one scale for each type of correction. The transformation is made by a range elevation relation scale or a range-range relation scale, depending on the type of pointing device on the gun. When no transformation is necessary a logarithmic range scale is used. Each of the three

types of scales mentioned is made up on a cloth-backed tape. Details on the construction of the scales are contained in appendix II. Only one scale is necessary under any particular set of conditions. The conditions under which each is required are as follows:

(1) When the gun is equipped with a range disk graduated for the combination of powder charge and projectile which is to be used, the scale required is a logarithmic range scale. (See note, (2) below.)

(2) When the gun is equipped to set ranges in angular units (that is, by setting elevations) a range elevation relation scale is used. This scale consists of a basic scale, which is a logarithmic range scale similar to that mentioned in (1) above; and a secondary scale which shows, beside the ranges in their proper relation, the elevations at which the gun must be pointed to attain those ranges with the particular combination of gun, powder charge, and projectile being used. These data are taken from the firing tables.

NOTE.—If the gun is equipped with a range disk, as is the usual case with fixed seacoast artillery, the range disk acts as the range elevation relation scale.

(3) If a gun equipped with a range disk is to be fired with a combination of powder charge and projectile different from that for which the range disk is engraved, an entirely different range elevation relation exists for which the range disk alone will not suffice. The problem that arises in this case is still the same as before, that is, to point the gun at a certain elevation. However, its solution requires an added step—the transformation of the desired elevation into terms of the ranges with which the range disk is graduated. This is accomplished by means of a range-range relation scale. It consists of two range scales, the first of which is a logarithmic scale similar to those mentioned in (1) and (2) above and which may be considered as the range to target scale. The second scale shows the ranges at which the range disk on the gun must be set in order to attain with the ammunition used the ranges given on the first scale.

b. Upon request, scales for the percentage corrector will be furnished by the Coast Artillery Board, Fort Monroe, Va.

To insure that the proper scales are furnished, requests should show—

- (1) Model of gun and carriage.
- (2) Whether range disk or elevation quadrant is used.
- (3) If range disk is used, the combination of projectile and powder charge for which the range disk is graduated, to include designation of firing tables used in graduating the range disk.
- (4) Statement of the combination or combinations of projectile and powder charge which are to be used for firing, to include designation of corresponding firing tables.

c. The percentage corrector consists of a box containing two rollers on which the proper one of the three scales is mounted. This scale shows through a window of xylonite on which is engraved a fixed index line for setting the uncorrected range. The ballistic correction scale is fixed in place on the top of the box alongside of the range scale with its normal opposite the setting index line. An index for the ballistic correction scale, called the "ballistic pointer," is fixed to a slide on the top of the box. The adjustment correction scale is also carried on this slide, its normal coinciding with the ballistic pointer. The read pointer is carried on a slide within the first slide. All correction scales are graduated logarithmically. The percentage corrector has on one side an auxiliary device known as an "interpolator" which is designed for use when employing a firing interval less than the interval between predictions on the plotting board. The interpolator consists of a wooden frame with two rollers in which is wound a range tape or an elevation tape. An interpolating plate rides in guides on top of the interpolator and is engraved with lines and figures as shown in figure 44. The plate may be moved freely in and out and the tape is moved over it. A small rider may be improvised for use on the tape if desired.

■ 92. OPERATION.—a. When the interpolator is *not* used one operator is required. He wears a telephone head set connecting him to the range or elevation setters at the guns. As soon as the uncorrected range to the set-forward point is called out from the plotting board, he sets that range on the range scale at the index line on the xylonite. He

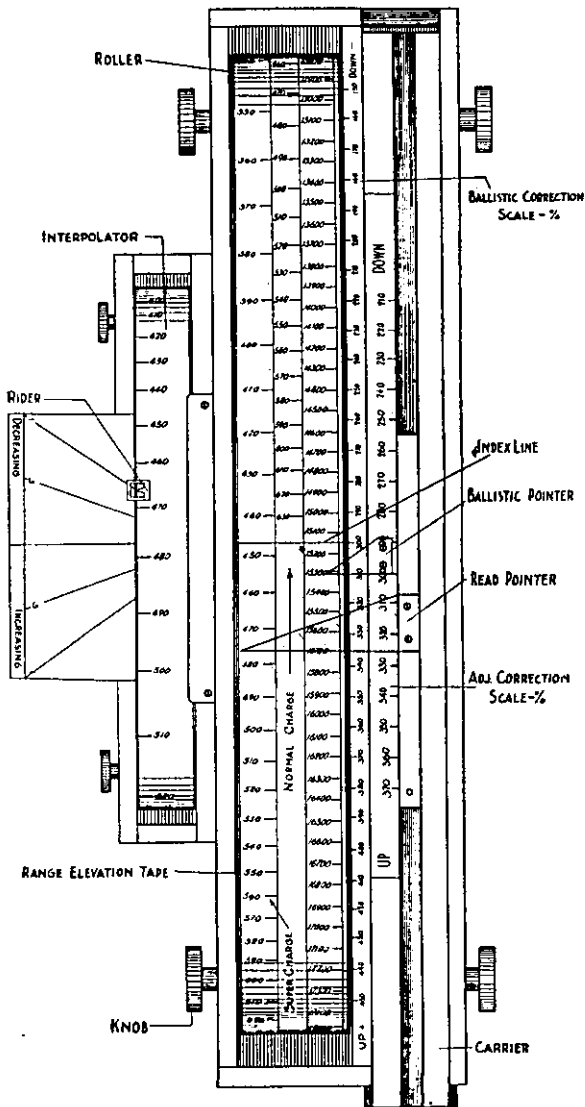

FIGURE 44.—Percentage corrector M1.

keeps the ballistic pointer set on the ballistic correction scale at the ballistic correction called out by the operator of the range correction board. If an adjustment correction has been ordered he sets the read pointer at that correction on the adjustment correction scale; otherwise the read pointer coincides with the ballistic pointer. He then calls out to the range or elevation setters at the guns the corrected range or elevation indicated by the read pointer on the range scale. He continues to make the proper settings of uncorrected ranges and corrections and to transmit the corrected firing data to the guns at the proper intervals. The new data should not be transmitted to the guns until after the sounding of the firing bell for which the previous data were figured. Whenever the operator receives a new adjustment correction he incorporates it into the next data and, when those data are sent, calls out CORRECTION APPLIED. All scales being logarithmic, the corrector acts as a logarithmic slide rule. Setting the ballistic pointer on the ballistic correction scale multiplies the range set at the normal of that scale by the amount of the ballistic correction. Setting the read pointer on the adjustment correction scale multiplies the range set at its normal—that is, the range already corrected for the ballistic correction—by the amount of the adjustment correction. This is equivalent to multiplying the uncorrected range by the product of the two corrections. In figure 44, the corrector is set for an uncorrected range of 15,150 yards, a ballistic correction of 310 (101 percent) and an adjustment correction of 326 (102.6 percent). This amounts to a total correction of 101.0 percent \times 102.6 percent = 103.6 percent. The corrected range indicated is 15,700 yards which is 103.6 percent of 15,150 yards. The elevation corresponding to the corrected range as indicated by the corrector is 477 mils.

b. When the interpolator is used two operators are required. The duties of the percentage corrector operator consist simply of setting the uncorrected ranges and the ballistic and read pointers. An additional operator operates the interpolator, wears the telephone head set, and transmits the corrected ranges or elevations to the guns. For the purpose of this explanation it will be assumed that predictions are to be

made every 30 seconds, that elevations are to be sent to the guns every 15 seconds, and that the time interval system is arranged to give three strokes of the bell every 30 seconds (known as the "3 bell") and one stroke at each intermediate interval of 15 seconds (known as the "1 bell"). The operation of the interpolator is then as follows:

(1) On the 1 bell, or as soon thereafter as practicable, the interpolator operator transmits to the guns the elevation (or corrected range) indicated by the read pointer. (This elevation is for firing on the next 3 bell.) He moves the tape so that this elevation is exactly over the center line of the interpolating plate and fastens the rider on the tape at this point.

(2) Immediately after the next 1 bell he transmits to the guns the elevation indicated by the read pointer and moves the interpolator tape so that the new elevation is exactly over the center line on the interpolating tape. This operation displacing the rider, he moves the interpolating plate in or out until one of the outer lines on the plate marked 1 intersects the tape at the index of the rider. The rider is then moved back to a position above the center line of the plate. If the range is increasing, the elevation to be sent to the guns on the next 3 bell is indicated where the tape is intersected by the 3 line on the side of the plate marked "increasing." For decreasing ranges the readings are on the other side of the center line. In figure 44 the elevation for the first 1 bell was 467 mils; for the second 1 bell, 477 mils. The elevation to be sent to the guns on the next 3 bell is indicated by the intersection of the 3 line with the tape on the increasing side of the plate, or 482 mils.

(3) The operations just described are repeated at the proper times, directly computed elevations (good for firing on the 3 bell) being sent to the guns immediately after each 1 bell and interpolated elevations (good for firing on the 1 bell) immediately after each 3 bell. In case a prediction is missed for any reason, an approximate elevation for the next 1 bell is always indicated by the intersection of the outer 1 line on the proper side of the plate.

(4) Should it be desired to lay the gun in elevation (or range) for times between 15 and 30 seconds data, resort may

be had to "creeping" on the range drum, or the operator of the interpolator may be taught to estimate readings, synchronizing them with a stop watch. In this way an almost continuous flow of elevations (or ranges) may be maintained and the guns fired whenever they are ready.

(5) If it is desired to furnish data at intervals that are smaller subdivisions of the interval between predictions, appropriately spaced lines may be marked on the reverse side of the interpolating plate and interpolations made in a manner similar to that described in (2) above.

CHAPTER 12

DIRECTION CORRECTION DEVICES

	Paragraphs
SECTION I. General	93
II. Deflection board, M1905 (for guns)	94-96
III. Deflection board, M1906 (for mortars)	97-100
IV. Universal deflection board	101-104
V. Angular travel computer	105-106
VI. Deflection board M1	107-110
VII. Azimuth adjustment slide rule	111-112

SECTION I

GENERAL

■ 93. FUNCTIONS.—The functions of direction correction devices depend upon the method of pointing used. In case II pointing, these functions are to determine and add algebraically the lateral corrections due to angular travel of the target during the time of flight to those for nonstandard ballistic conditions, drift, and adjustment, and to indicate the total deflection for use on the gun sights; in case III pointing, they are to determine those same corrections, except for angular travel which is no longer involved, and add them algebraically to the uncorrected azimuth of the set-forward point. All of these operations may be performed on the deflection board, supplemented by the wind component indicator and, in one case, by the angular travel computer. On all lateral pointing instruments for seacoast artillery, an increased azimuth (or deflection) setting will cause the gun to shoot to the right. Therefore, the conventional method on computing instruments is to show azimuths and deflections increasing toward the right on straight scales and clockwise on circular scales, and the instruments are so constructed that corrections to the right will increase, and corrections to the left decrease, the azimuth or deflection. The coast artilleryman's shibboleth is "Right—Raise; Left—Lower."

SECTION II

DEFLECTION BOARD, M1905 (FOR GUNS)

■ 94. DESCRIPTION.—The deflection board, M1905 (fig. 45), is an old type of instrument (see par. 107) designed to compute deflections for case II pointing in combination with the Whistler-Hearn plotting board. It provides means for determining the lateral corrections due to angular travel of the target during the time of flight, wind and drift, and for adding algebraically those corrections and the lateral adjustment correction, giving a deflection for use on the gun sights. It does not make any correction for rotation of the earth. While this board is very satisfactory for case II pointing, it is not satisfactory for and should not be used for case III pointing except in emergencies. (See par. 101.) A method of adapting it for case III pointing is discussed in *g* below. Deflection boards similar in essential features are the M1905M1 and the M1917 boards. Only the M1905 board will be discussed.

a. Board and platen.—The instrument consists of two main parts, a rectangular wooden board (*B*) and a metal frame (*A*) called a platen. A rod (*C*) extends across the surface of the board near and parallel to its lower edge. The rod passes through the platen which may be slid along the rod or clamped to it. Two lines are marked on the platen—one, called a "reference line," along its lower edge and parallel to the rod; and the other, called a "median line," along its center and perpendicular to the reference line.

b. Deflection scale.—Deflections are indicated on the deflection scale which is fixed to the surface of the board at its lower edge. This scale is also parallel to the rod. It is graduated in degrees and hundredths, increasing to the right, and is marked in reference numbers for deflection. (See par. 53.) The scale is 1 inch=0.50°.

c. Travel computing mechanism.—(1) This mechanism consists of a platen scale, a travel arm, and a range time scale. The platen scale is engraved on both sides, one side, marked 15 seconds, to the same scale as the deflections; the other side, marked 30 seconds, to twice that scale. Both scales are marked in terms of travel reference numbers with 15 as normal. Two positions are provided on the platen for the

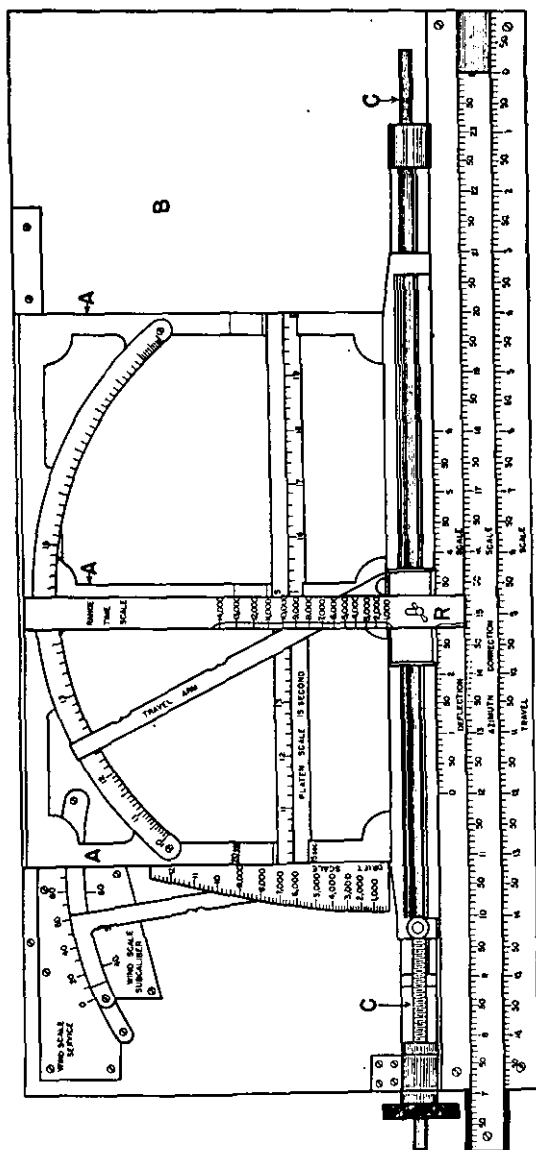

Figure 45.—Deflection board, M1905 (for guns).

insertion of the scale. The lower position places the scale 3 inches from the reference line and is marked 15 seconds; the upper position places it 4 inches from the reference line and is marked 20 seconds. The platen scale, in either position, is parallel to the reference line with its normal at the median line. The travel arm is pivoted to the platen at the intersection of the reference and median lines with its reading edge passing through that point. The range time scale is mounted on and slides along the rod independently of the platen. Its reading edge is maintained parallel to the median line. It is engraved in units of time of flight to a scale of 1 inch=5 seconds but for convenience in operation is marked in terms of the corresponding ranges. Separate range time scales are furnished for service and subcaliber firings for each combination of gun, powder charge, and projectile.

(2) The correction for angular travel is computed on the principle of similar triangles. Figure 46 shows the set-up of the travel computing mechanism for a 15-second observing interval, a 20-second time of flight, and a measured travel

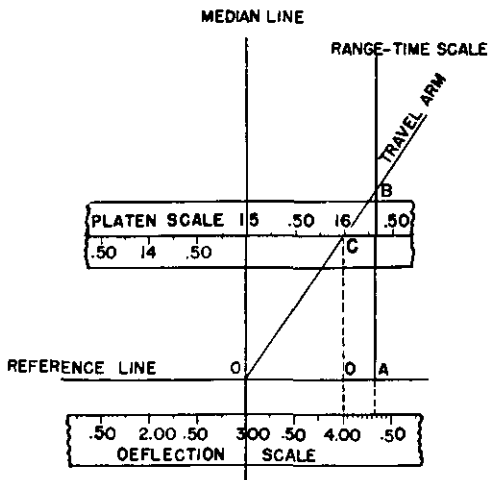

FIGURE 46.—Computation of travel correction on deflection board, M1905.

of the target of 1° during the observing interval. The 15-second platen scale is placed in the lower (15-second) position. The travel during the observing interval is set off on the platen scale by the travel arm. Therefore, in the triangle OCD (fig. 46), $CD=3$ inches=15 seconds, and $OD=2$ inches= 1° . If the range time scale is moved laterally until its reading edge intersects the reading edge of the travel arm at the range graduation corresponding to a time of flight of 20 seconds ($AB=4$ inches), the distance OA will represent to scale the travel during the time of flight. The mathematical solution is $OA: 1^\circ=4$ inches : 3 inches= 1.33° . This is equivalent to a deflection setting of 4.33, as is indicated by the intersection of the range time scale with the deflection scale. If the same travel occurred in the other direction the deflection indicated would be 1.67. For an observing interval of 20 seconds, the 15-second scale is placed in the 20-second position, making $CD=4$ inches=20 seconds. For a 30-second observing interval, the correct proportion would be made by either doubling CD or halving OD . The latter method is used on the board. This is done by reversing the platen scale and placing the double scale in the 15-second position, making OD (which would still represent $1^\circ=1$ inch. For a 40-second observing interval, the 30-second scale is placed in the 20-second position. On some boards an additional 30-second scale (shown in fig. 45) in the form of an arc is provided on the platen. This scale also is marked in terms of travel reference numbers.

NOTE.—In this connection it should be noted that the use of an observing interval greater than 20 seconds is not good practice. (See pars. 39 and 40.)

d. Wind and drift computing mechanism.—(1) The computing mechanisms for wind and drift are combined. They consist of two wind scales, one for service and the other for subcaliber firings; a wind arm; and a drift scale for each combination of gun, powder charge, and projectile. In figure 45, the wind scale for service firing is shown fixed in place in the upper left-hand corner of the board. The position of the subcaliber wind scale is just under the service wind scale. Both scales are graduated in wind reference numbers with 50 as normal. (See par. 55.) The wind arm

is pivoted to the board with its center coinciding with the reference line of the platen and its reading edge passing through that center. The same index on the wind arm is used for both wind scales. The drift scale has a curved reading edge engraved with graduations marked in terms of range. It is attached to the left edge of the platen and moves with it. When the platen is moved laterally until the origin of the drift curve (at zero range) coincides with the center of rotation of the wind arm, the median line of the platen coincides with the normal of the deflection scale. If the platen is moved laterally from that position, the travel computing device is offset accordingly and the deflection indicated by the range time arm is increased or decreased. If the wind arm is set to the proper wind reference number on the wind scale and the platen moved until the drift scale intersects the wind arm at the range to the set-forward point, the indicated deflection will include the correction for wind and drift.

(2) The principles of construction of the wind and drift computing mechanism are illustrated in figure 47. The point *P* represents the origin of the wind and drift curves. The normal wind curve, that is, the curve of zero corrections, is represented by the straight line from the origin to the reference number 50. The position of the reference number 40 is determined by the angle α which may be arbitrarily chosen within the limits of the board. This marks the position of the wind curve for a 10-mile cross wind blowing from the left. The wind effect is indicated by the lateral displacement, such as *OA*, parallel to the reference line, of any point *A* from the normal line *OP*, and if the platen is offset by this amount and in this direction the wind correction will be added algebraically to the deflection. The value of any displacement *OA* depends upon the length of the ordinate *OP* and, since the wind effect varies as the time of flight or the range, the ordinates may be marked in terms of the range. They are shown on the drift scale. For example, in the figure the displacement *OA*, when constructed to the scale of the board, is equal to the wind effect of a 10-mile cross wind on a projectile fired at a range of 10,000 yards. In determining the values of the remaining

angles, such as β and γ , the assumption is made that the wind effects, and therefore the necessary corrections, vary directly as the wind velocity. (An inspection of the firing tables will disclose that this assumption is very nearly correct.) Therefore, the position of the lines BP and CP , which represent the wind curves for a 20-mile and a 30-mile cross wind blowing from the left, must be so determined that $OB=2 OA$ and $OC=3 OA$. This relation will hold if $\tan \beta=2 \tan \alpha$ and $\tan \gamma=3 \tan \alpha$. This relation determines the

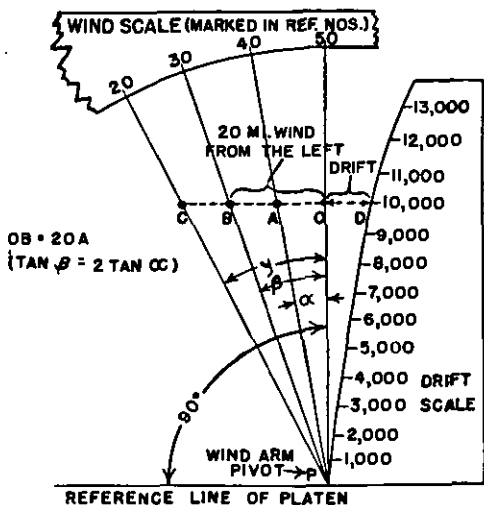

FIGURE 47.—Computation of wind and drift corrections on deflection board, M1905.

location of the reference numbers "30" and "20" on the wind scale. The positions of the remaining wind reference numbers, including those for a wind blowing from the right, may be found in the same manner and the wind scale marked accordingly.

(3) Since the drift effect also varies as the time of flight, the same ordinates may be used in constructing the drift curve. The lateral effects are obtained from the firing tables

and plotted as abscissas opposite the ordinates already located. They are measured from the 50-wind line as an origin. For example, in figure 47 the lateral displacement OD is equal to the drift effect on a projectile fired at 10,000 yards' range. Figure 47 shows the normal (50) wind curve perpendicular to the platen reference line, as is the case on the deflection board when using the subcaliber wind scale. When using the service wind scale the normal line is displaced slightly to the left of the perpendicular, and a constant is introduced into the calculation that displaces the drift curve to compensate. By these means the drift curves may be straightened and the board made more compact.

(4) The wind scales, both service and subcaliber, are the same on all boards of this type. The proper wind corrections for different combinations of cannon, powder charge, and projectile are obtained by constructing separate drift scales for each combination of conditions, on which the ordinates are varied to suit the particular combination. The drift corrections are varied by constructing the drift curves with the proper abscissas.

e. Lateral adjustment corrections.—The lateral adjustment correction may be applied to the deflection by use of the azimuth correction scale. This scale is placed in a slide just below the deflection scale. It is graduated in degrees to the same scale as the deflection scale, and because it was originally designed for use with the azimuth correction scale on the gun arm of the Whistler-Hearn plotting board it is marked in those reference numbers with 15 as normal. It may be adapted for use in applying lateral adjustment corrections by re-marking the full degree graduations like those of the deflection scale with 3 as normal. With the scale so re-marked, adjustment corrections may be applied by setting the adjustment correction ordered, in reference numbers, on the azimuth correction scale opposite the normal on the deflection scale. This will offset all readings on the correction scale by the same amount from the corresponding readings on the deflection scale above. The corrected deflection may then be read as indicated by the range time arm on the azimuth correction scale. The adjustment correction used should in each case be the algebraic sum of all adjustment corrections made.

f. Differences in boards in service.—The boards in service differ slightly from each other in one or more particulars. Some of the improvements made in later boards have been incorporated on some of the earlier boards. Examination of the particular board in use will disclose the following differences on the later types:

(1) The left edge of the travel arm is the fiducial edge and the other edge is serrated to prevent its use through mistake. On the earlier type the right edge is the fiducial edge. The other edge should be serrated locally to prevent its use. In either case the proper edge to use is the one which if extended would pass through the travel arm pivot.

(2) The wind arm is serrated on its rear edge to distinguish that edge from the fiducial edge.

(3) The travel scale at the bottom of the board, now obsolete, is omitted. A plain bearing strip is substituted.

(4) There is an arrow pointing downward on the deflection scale just below the normal (3°), used as an index for setting the azimuth correction scale.

(5) A set screw is provided so that the range-time scale can be clamped to the rod if desired.

g. Adaptation to case III pointing.—The board may be adapted to case III pointing methods by substituting an azimuth tape for the azimuth correction scale. The tape should be graduated to the same scale as the deflection scale, that is, 1 inch= 0.50° , and marked in azimuths from 0° to 360° , increasing from left to right. It should be mounted on rollers for convenient setting of azimuths. If the uncorrected azimuth is set opposite the normal of the deflection scale, the corrected azimuth may be read opposite the reading edge of the range time scale. Lateral adjustment corrections may be applied by using the 15-second platen scale as an adjustment scale, changing the normal of that platen scale to 3.

■ 95. OPERATION.—*a. Case II pointing.*—The operator of the board wears a telephone head set connecting him to the gun pointers at the guns. He selects the proper scales for use and installs them in place on the board. He notes the wind reference number for the deflection component of the wind as given by the wind component indicator and sets the wind

arm to that number on the wind scale. He sets the travel arm to the travel reference number (as received from the angular travel device operator at the plotting board) on the platen scale. (See pars. 106 and 107.) He notes the range to the set-forward point as called out by the plotter and moves the platen laterally until the drift scale intersects the wind arm at that range. (For large movements the platen should be unclamped and slid; for small movements it should be clamped to the rod and the rod moved laterally by turning the handwheel at its left end.) He sets the range time scale to that range on the travel arm. He sets the lateral adjustment correction (obtained from the range officer) on the azimuth correction scale (see par. 94e) at the normal to the deflection scale and reads the deflection, as indicated by the reading edge of the range time scale on the azimuth correction scale, calling this deflection to the gun pointers. He continues making the proper settings of wind, travel, range, and adjustment correction and transmits the corrected deflections to the guns at the proper intervals. Whenever the operator receives a new adjustment correction he incorporates it into the next data, and when those data are set he calls out CORRECTION APPLIED.

b. Case III pointing.—The operator wears a telephone head set connecting him to the azimuth setters at the guns. He sets the wind arm and drift scale as before but keeps the range time scale clamped at the median line of the platen. He sets the uncorrected azimuth to the set-forward point (as received from the plotter) opposite the normal of the deflection scale and reads the corrected azimuth on the azimuth tape opposite the reading edge of the range time scale. When a lateral adjustment correction is ordered he moves the range time scale to that correction on the platen scale (as modified; see par. 94g). He then proceeds with the normal operation of the board, reading the corrected azimuth as before.

■ 96. ACCURACY TESTS.—Several sets of data are indicated on the board for use in testing the accuracy of the computing mechanisms. Each set includes settings for the wind arm, the drift scale, and the travel arm, together with the resulting deflection. Checks may be made also with data taken from the firing tables.

SECTION III

DEFLECTION BOARD, M1906 (FOR MORTARS)

■ 97. **DESCRIPTION.**—*a. General.*—The deflection board, M1906 (fig. 48), is an older type deflection board. (See par. 107.) It is a device for applying to the uncorrected azimuth of the set-forward point the lateral corrections for wind, drift, and adjustment. It does not apply corrections for rotation of the earth. Although designed originally for use with mortars, it is a satisfactory instrument for case III pointing with any type of cannon for which wind and drift charts are available. The instrument consists of a cylinder, a surrounding frame, a carriage, and a slide. The carriage is mounted on the frame and may be moved across it laterally by operating the main traversing handwheel on the right side of the board. Fixed to the right end of the carriage is the uncorrected azimuth pointer marked "set." The lateral wind correction scale is fixed to the other end of the carriage at a constant distance from the set pointer. Riding above that scale but not fixed to it is the adjusting scale. The slide rides on the carriage and may be moved laterally on the carriage by operating the slide knob on its right front. The slide bears on its left end a mount for the wind and drift correction chart and on its right end the corrected azimuth pointer marked "read."

b. Azimuth indicating mechanism.—The whole degrees of azimuth are marked on the surface of the cylinder in 36 rows. Each row begins with a whole degree number ending with the digit 1 and contains 21 numbers increasing to the right; its first number is greater by 10 than the first number of the preceding row. The cylinder may be rotated by operating the handle and ratchet ring at its left end. A window is provided in the frame where one row at a time of the azimuth scale may be seen. This arrangement allows the use of a graduated subscale covering only 20° for any azimuth setting. The subscale is on the frame just below the window. It shows graduations for each 0.05°. The full degree graduations appear under the full degree markings on the cylinder. Both the set pointer and the read pointer register on this subscale. If in setting the uncorrected azimuth a

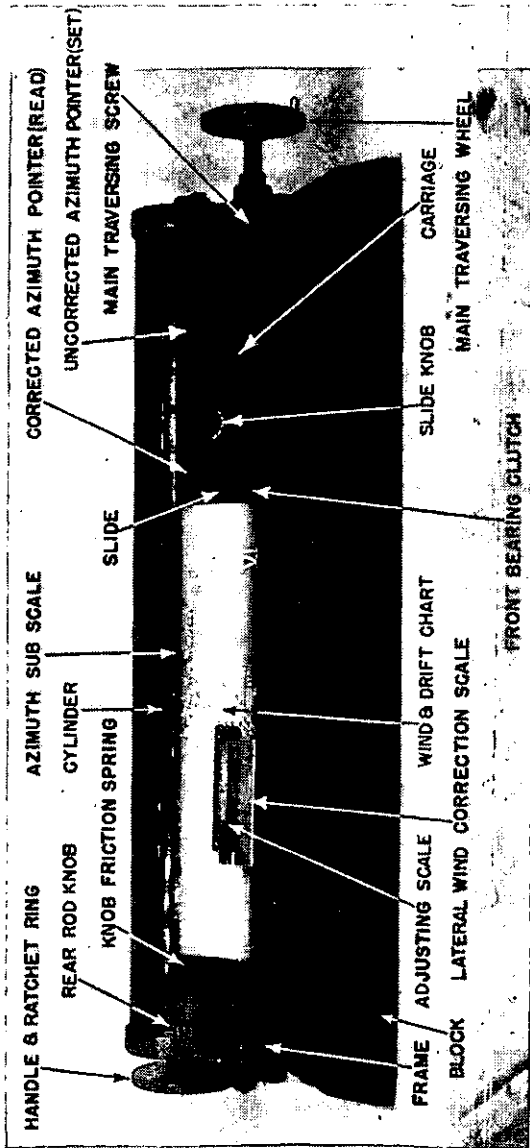

FIGURE 48.—Mortar deflection board, M1906

stop is encountered before the proper setting can be made, the cylinder must be rotated to bring the next row of degrees into view. This will make the setting possible.

c. *Wind and drift computing mechanism.*—(1) The wind and drift curves are curves of the combined effect of cross wind and drift plotted with effects in degrees and hundredths as abscissas and elevations in degrees and minutes as ordinates. They are constructed from firing table data; a set of curves must be constructed for each combination of mortar, powder charge, and projectile—that is, for each zone—throughout the range of the armament. The curves are marked in terms of wind reference numbers with 50 as normal. The combined effect of wind and drift for a particular ballistic wind and elevation is measured by the lateral distance from the origin line of the curves to the intersection of the wind curve with the elevation line. The chart is mounted on rollers permitting movement perpendicular to the slide. When mounted in proper position, the origin or zero line of the curves at the left edge of the chart is at the same lateral distance from the read pointer as the normal of the lateral wind correction scale is from the set pointer.

(2) The adjusting scale is held above the chart with its edge parallel to the elevation lines. This scale is marked with an index near its center. (It is also graduated in deflection reference numbers with the normal (3) at the index, but due to modification of the board those graduations are no longer used.) The normal position of the adjusting scale on the carriage is with its index at the normal of the lateral wind correction scale.

(3) The lateral wind correction scale is mounted on the carriage under the adjusting scale. It is graduated in deflection reference numbers increasing from left to right with 3.00 as normal. (This scale gets its name from its original purpose, that is, for applying wind corrections. It is now used for applying adjustment corrections.)

(4) Corrections for wind and drift are applied mechanically to the uncorrected azimuth by changing the relative lateral positions of the carriage and the slide and, therefore, of the set and read pointers. When the adjusting scale is

at its normal position on the carriage and the slide is at such position that the origin line of the wind and drift curves coincides with the index of the adjusting scale, the set and read pointers coincide. The set pointer is set to the uncorrected azimuth of the set-forward point by moving the carrier. Since this also moves the slide and the read pointer, the two pointers still coincide. Movement of the slide to set the proper wind curve at the index of the adjusting scale will offset the read pointer laterally by the amount of the combined correction for wind and drift for that elevation.

d. Lateral adjustment corrections.—These corrections are applied by offsetting the adjusting scale from its normal position on the carriage (3 on the lateral wind correction scale). The index of the adjusting scale is set to the adjustment correction ordered on the lateral wind correction scale. The slide is then moved until the wind curve is brought to the new position of the index. This displaces the read pointer by a corresponding amount to include the adjustment correction. The adjustment correction thus applied is a flat, angular correction giving a linear correction proportional to the range. This is satisfactory for low angle fire. For high angle fire, however, the correction should vary more nearly as the elevation or the time of flight and not as the range. The adjustment correction should then be modified by use of the azimuth adjustment slide rule described in paragraph 112.

■ 98. ADJUSTMENT.—The chart must be adjusted so that its origin line is at the same distance from the read pointer as the normal of the lateral wind correction scale is from the set pointer. The procedure is as follows:

Bring the read pointer over the set pointer by operating the slide knob. Set the index of the adjusting scale to the normal of the lateral wind correction scale. Adjust the chart so that the origin line of the curves is directly under the index of the adjusting scale and is perpendicular to it.

■ 99. OPERATION.—The operator of the board wears a telephone head set connecting him to the azimuth setters at the guns. He selects the proper set of wind and drift curves for

the firing (as directed by the range officer) and adjusts the position of the chart. He sets the adjusting scale at its normal position on the lateral wind correction scale. He rotates the cylinder until the appropriate markings of the azimuth scale are in view and operates the main traversing hand-wheel to set the set pointer at the uncorrected azimuth of the set-forward point (as called out by the plotter). He operates the rear rod knob to bring the horizontal line on the chart representing the corrected elevation (as called out by the percentage corrector operator) to the edge of the adjusting scale. He sets off the adjustment correction as received from the operator of the azimuth adjustment slide rule by setting the index of the adjusting scale to that reading on the lateral wind correction scale. He notes the reference number of the deflection component of the ballistic wind as shown on the wind component indicator and operates the slide knob to set that curve on the chart at the index of the adjusting scale. Opposite the read pointer he reads the corrected azimuth calling it to the azimuth setters at the mortars or guns). He continues making the proper settings of uncorrected azimuth, corrected elevation, and wind and transmits the corrected azimuths to the guns at the proper intervals. Whenever the operator receives a new adjustment correction he incorporates it into the next data, and when those data are sent he calls out CORRECTION APPLIED. When firing is by zones he notes any change of zones ordered and brings the corresponding wind and drift curves into place on the board.

■ 100. ACCURACY TESTS.—The accuracy of the wind and drift curves may be checked by data taken from the firing tables.

SECTION IV

UNIVERSAL DEFLECTION BOARD

■ 101. DESCRIPTION.—*a. General.*—(1) The universal deflection board (fig. 49) may be used for either case II or case III pointing for any type of cannon for which the necessary correction curves are available. When used for case III pointing it provides means for applying to the uncorrected azimuth to the set-forward point the lateral corrections due to drift, to adjustment, and to all nonstandard ballistic con-

ditions. When used for case II pointing it provides means for adding the correction due to angular travel to those corrections, giving a deflection setting for the gun sights. The correction due to angular travel must be computed on a separate instrument. (See pars. 105 and 106.)

(2) This board was designed to replace the M1905 and M1906 boards but before it was standardized for issue the M1 board (see sec. VI) was developed and made standard. As a result very few universal boards were issued to using batteries. The board can be constructed cheaply and easily and its use is recommended to those batteries not supplied with the M1 board. Azimuth tapes and correction curves may be obtained upon request from the Coast Artillery Board, Fort Monroe, Va.

(3) The main mechanical parts of the instrument are a board, a carrier, a rider, a pointer arm, and a slide. The board is usually suspended vertically. There are two rollers at the lower corners for mounting the azimuth tape. A set of curves for wind and drift corrections is mounted on the face of the board. The carrier is mounted in a slot allowing lateral movement across the board. It carries on a vertical arm the rider which may be moved along that arm to bring the pointer arm to the proper range or elevation line. Curves for rotation corrections are fixed to the carrier arm. The pointer arm slides laterally in the rider. It bears two pointers, one for use with the wind and drift curves and the other for use with the rotation curves. The slide is mounted on the lower part of the board independently of the carrier. It may be moved laterally across the board. The slide bears on its left end the adjustment correction scale and at its center the uncorrected azimuth (or deflection) index (marked "set index" in the figure). The corrected azimuth index (marked "read index") is on the lower extension of the carrier.

b. Azimuth indicating device.—Two types of tapes are furnished as follows:

(1) *For azimuths in degrees and hundredths.*—This tape is graduated to a scale of 1 inch = 1° , $\frac{1}{20}$ inch being equivalent to 0.05° which is the least reading. The tape covers 100° and indicates the tens, units, and hundredths of degrees of azimuth. The hundreds of degrees are shown in

a circular window over the setting index. A slide marked with numbers from 1 to 6 (see (2) below) slides laterally in a groove under the window. The hundreds digit is set by moving this slide until the proper figure shows through the window. The reading of the setting index, in figure 49, is approximately 280.80° . (Owing to the reduced scale of the drawing, the 0.05° graduations are not shown in the figure.) Both setting and reading indices register on this scale. This tape carries at one end three deflection scales for use with case II pointing. These scales differ only in their limiting readings and in the positions of their normals. The normals are 3.00, 6.00, and 10.00. (See par. 53.) All three scales are graduated 1 inch to a degree with a least reading of 0.05.

(2) *For azimuths in mils.*—This tape is graduated to a scale of 1 inch=10 mils with a least reading of 1 mil. Each 10-mil graduation is numbered. The tape covers 1,000 mils and indicates the hundreds, tens and units of mils of azimuth. The thousands of mils are shown in the circular window in the same manner as are the hundreds of degrees when using the tape described in (1) above. The tape also carries at one end three deflection scales for use with case II pointing, each scale being graduated to correspond to the graduations of a particular type of sight. Two of these scales are graduated in mils, to the same scale and with the same least reading as the main tape, one having numbers increasing to the left and the other having numbers increasing to the right. The third scale is graduated in degrees from 1° to 6° , with 3° at the center, the smallest division of the scale being 0.05° . On this scale 1° (17.78 mils) is represented by 1.778 inches, since it must correspond to the horizontal scale used in constructing the wind and drift curves, the rotation curves, and the main tape. If it is desired to eliminate the use of the circular window in setting the hundreds of degrees or the thousands of mils, the proper digit for a particular field of fire may be marked on the tape furnished or a special tape may be constructed for that purpose.

c. *Wind and drift computing device.*—The wind and drift curves are attached to the board. They are curves of the

combined effect of cross wind and drift and are similar to those on the M1906 board except that the origin line of the curves (zero correction) is at the right instead of at the left, due to a difference in the mechanical construction of the board. The curves are marked in terms of wind reference numbers with 50 as normal. These curves, as well as the curves for rotation, must be constructed for each particular combination of cannon, powder charge, and projectile. (The horizontal scale for construction of these curves is the same as the scale of the tape to be used; that is, either 1 inch= 1° or 1 inch=10 mils. The vertical scale is variable.) The wind pointer is on the pointer arm. Uncorrected azimuths (or deflections) are set opposite the setting index fastened to the slide. Corrected azimuths (or deflections) are read opposite the reading index fastened to the carrier. Corrections for wind, drift, and rotation are applied mechanically by offsetting the carrier. The distance it must be offset to correct for wind and drift, for a particular ballistic wind and elevation, is the lateral distance between the origin line of the wind curves and the intersection of the wind curve with the elevation line. This is done by use of the wind pointer. With the carrier at normal (read index over set index) the pointer arm is moved until the wind pointer is opposite the origin line of the wind curves. The carrier is then moved until the wind pointer is opposite the proper wind curve, and the reading index will indicate the azimuth corrected for wind and drift.

d. Rotation computing device.—(1) The rotation curves are attached to the vertical arm of the carrier. They are plotted from firing table data with effects in degrees and hundredths (or mils) as abscissas and with elevations (or ranges) as ordinates. The scale of the abscissas and of the ordinates is the same as that of the wind curves. An ordinate scale is fixed to the carrier arm at the left of the chart and may be used for both sets of curves. Each curve is plotted for a particular azimuth of the target and labeled accordingly. Three curves are shown, one for 0° and 360° , one for 90° and 270° , and one for 180° . The origin line of the curves is shown at the left of the chart. All curves for positions within the United States are constructed for 30°

North latitude. (See note, par. 83.) The effect of rotation for a given elevation and a given azimuth is indicated by the lateral distance between the origin line and the intersection of the azimuth curve with the elevation line. The rotation pointer is on the pointer arm at the right of the wind pointer.

(2) The rotation correction is added algebraically by offsetting the wind pointer by means of the rotation pointer. Those pointers are separated by the same distance as the origin lines of the two sets of curves. If the rotation pointer is moved to the proper azimuth curve, the wind pointer will be moved away from its origin line by the amount of the rotation correction, and it will be necessary to move the carrier by an additional amount to reset the wind pointer opposite the proper wind curve. The reading index will then indicate the azimuth (or deflection) corrected for wind, drift, and rotation.

e. Adjustment corrections.—Adjustment corrections are applied by offsetting the setting index by moving the slide. The adjustment correction scale is fixed to the slide, and the correction pointer is fixed to the board. When the setting index is at its normal position (on the origin line of the wind and drift curves) the normal (3.00, 0.00, or 0; see below) of the scale should be opposite the correction index. If the scale is set to the adjustment correction ordered, the setting index will be offset by the amount of the correction. This causes the azimuth tape to be moved accordingly in order to keep the uncorrected azimuth or deflection set opposite the setting index. The reading index will then indicate the azimuth or deflection corrected for adjustment. (Three adjustment correction scales are furnished, two graduated in degrees and one in mils. The two in degrees are to the scale of 1 inch=1°, with least reading of 0.05; one is numbered with reference numbers from 0 to 6 with 3.00 as the normal; the other is numbered from 1 to 3 on either side of the 0.00 normal. The mil scale is graduated to a scale of 1 inch=10 mils, extending 30 mils either side of the normal which is 0. The selected scale must be fixed to the slide in the proper position.)

f. Travel corrections.—When using this board for case II pointing the correction for angular travel is computed on the

angular travel computer (par. 105) or a similar instrument. This value is set opposite the setting index on the deflection board, using the deflection scale on the tape that is appropriate for the particular gun sight being used. The corrections for wind, drift, and rotation are applied in the same manner as described above.

■ 102. ADJUSTMENT.—The adjustment of the board consists of establishing the proper relations between all pointers and indices at their normal positions. Those positions are as follows:

a. *Reading index*—opposite the origin line of wind and drift curves.

b. *Setting index*—directly over the reading index.

c. *Wind pointer*—opposite the origin line of wind and drift curves.

d. *Rotation pointer*—opposite the origin line of rotation curves.

e. *Adjustment correction pointer*—opposite the normal (3.00) of the adjustment correction scale.

■ 103. OPERATION.—a. *Case II pointing*.—The operator of the board wears a telephone head set connecting him to the gun pointers at the guns. He checks the adjustment of the board. He selects the proper wind, drift, and rotation curves for the firing and attaches them to the board. He sets the deflection scale with the deflection, called out by the operator of the angular travel computer at the setting index. He notes the elevation, called off by the percentage corrector operator, and sets the rider at that elevation. He notes the uncorrected azimuth to the set-forward point, called out by the plotter, and sets the rotation pointer to that curve by moving the pointer arm. He notes the deflection component of the ballistic wind, shown on the wind component indicator, and sets the wind pointer to that curve by moving the carrier. He sets the adjustment correction ordered by moving the slide until that correction is opposite the correction pointer, and resets the uncorrected deflection opposite the setting index. Opposite the reading index he reads the corrected deflection, calling it to the gun pointers at the guns. He continues to make the proper settings, and transmits the cor-

rected deflections to the guns at the proper intervals. Whenever he receives a new adjustment correction he incorporates it into the next data, and when those data are sent he calls out CORRECTION APPLIED.

b. Case III pointing.—The only variation for case III pointing is in the initial setting. In this case he sets the uncorrected azimuth (as called out by the plotter) opposite the setting index.

■ 104. ACCURACY TESTS.—The accuracy of the correction curves may be checked by data taken from the firing tables.

SECTION V

ANGULAR TRAVEL COMPUTOR

■ 105. DESCRIPTION.—*a.* The angular travel computor (fig. 50) is used to determine in reference numbers, the deflection corrected for angular travel of the target during the time of flight, for use on the universal deflection board. If modified as indicated in paragraph 106*b* it may be used to determine the angular travel during the observing interval for use on the deflection board, M1905. The instrument is not an article of issue but may be constructed locally if desired. The principles of construction are similar to those of the travel-computing mechanism on the M1905 deflection board. (See par. 94*c*.)

b. (1) Referring to figure 50, the scale *K* at the bottom of the board acts as the platen scale; the scale *E* on the slide *D* is the deflection scale; the range scale at the right is the range time scale; and the arm *H* is the travel arm. The platen scale is graduated in azimuths and is movable so that the uncorrected azimuth may be set at *J* on the median line. The travel arm *H* is set along the platen scale to the next uncorrected azimuth received from the plotter. This sets up one triangle with horizontal side proportional to travel during the observing interval and vertical side proportional to the length of the observing interval. The deflection scale *E* is then set at the range to the set-forward point (as indicated on the range scale), making the vertical side of the second triangle proportional to the time of flight. The horizontal side is therefore proportional to the travel during the time

of flight. The deflection scale *E* is graduated and marked in deflection reference numbers with the normal at the median line of the board; that in the figure has a normal of 6.

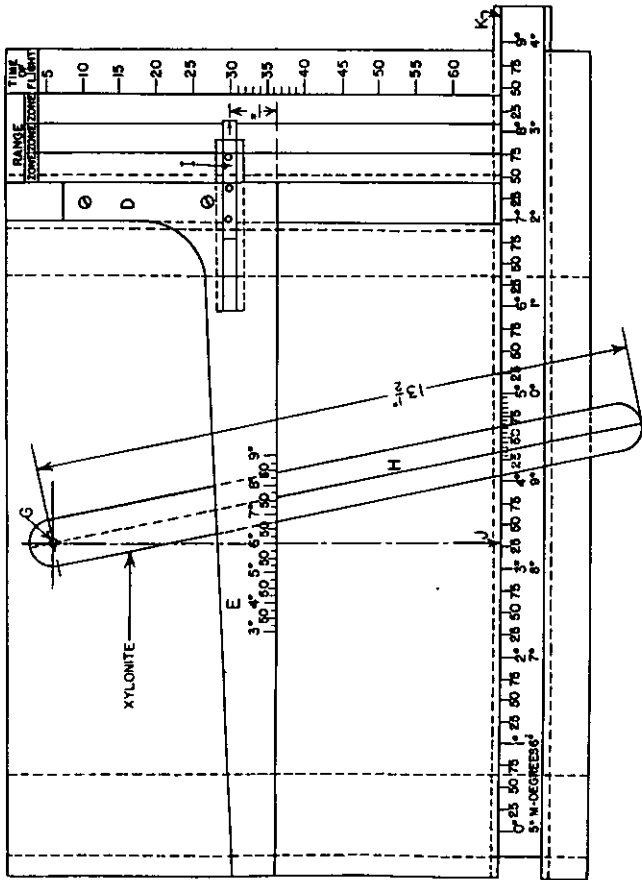

FIGURE 50.—Angular travel computer.

(2) The instrument illustrated is constructed with the platen scale at a fixed distance from *G* equal to 60 seconds on the range time scale. The length of the observing in-

terval thus represented depends on the ratio of the platen scale to the deflection scale. For example, in the figure that ratio is equal to $\frac{1}{3}$. The observing interval is therefore equal to $\frac{1}{3} \times 60 = 20$ seconds. (See par. 106b.)

(3) For each particular combination of gun, powder charge, and projectile, a range scale is constructed to show ranges corresponding to the times of flight shown on the time of flight scale. This range scale is inserted in its proper position with respect to the time of flight scale shown.

(4) The platen scale is graduated in units and hundredths of degrees of azimuth with a least reading of 0.05° . By dropping the hundreds and tens of degrees and setting only the units and hundredths, a scale 9° long may be used for setting all azimuths.

■ 106. OPERATION.—*a. With universal deflection board.*—The operator sets the last uncorrected azimuth to the set-forward point (as called out by the plotter) at the index *J*. He notes the uncorrected azimuth and range to the next set-forward point. He sets the travel arm at that azimuth on the platen scale and the deflection scale at that range on the range scale. He calls out to the operator of the universal deflection board the deflection as indicated by the travel arm on the deflection scale. This procedure is repeated for each set-forward point.

b. With deflection board, M1905.—The angular travel computer must be modified so that 1° on the deflection scale equals 1° on the platen scale, and the deflection scale must be marked in reference numbers to correspond to those on the platen scale of the deflection board. The slide *D* is moved down so that the reading edge of the deflection scale *E* is against the reading edge of the platen scale *K* with the normal of the scale at *J*. The range scale is not used. Azimuths of successive set-forward points are set as in *a* above, and angular travel reference numbers are read from the deflection scale and called out to the deflection board operator. (A simple slide rule either straight or circular may be constructed to take the place of the angular travel computer when using the M1905 deflection board.)

SECTION VI

DEFLECTION BOARD M1

■ 107. DESCRIPTION.—*a. General.*—The deflection board M1 (fig. 51) is the present standard instrument for determining the corrected azimuth or deflection for seacoast artillery firing. It computes the lateral corrections due to travel, wind, drift, and rotation of the earth and applies adjustment corrections. It can be used for either case II or case III pointing with any type of cannon for which wind, drift, and rotation curves are available. It can be adjusted to operate either in degrees and hundredths or in mils by a replacement of gearing and changing of scales and correction curves. An additional feature on this board (when operating in degrees) is a mechanism for correcting the firing data for parallax due to displacement. In the discussion following it is assumed that the board is adjusted to operate in degrees and hundredths unless otherwise stated. The base of the board is a frame with a vertical pintle located centrally therein.

b. Azimuth indicating mechanism.—The main azimuth plate rests on a shoulder of the pintle and rotates freely about the pintle as an axis. A circular scale about its edge is engraved in units and hundredths of degrees with a least reading of 0.05° . It is divided into four quadrants, each quadrant representing 10° of azimuth. The hundreds and tens of degrees of azimuth are shown on two auxiliary azimuth scales, geared at a ratio of 9 to 1 to the main azimuth plate through a socket on the pintle. One scale is on the base plate of the wind component indicator mechanism and the other on the base plate of the displacement correction mechanism. The former is conveniently placed for use in setting the uncorrected azimuth and the latter for use in reading the corrected azimuth. Each 10° of azimuth on these plates and each quadrant on the main azimuth plate are marked with alternate black and white spacings just inside the graduations. In assembling the instrument the black sectors on each scale should match, and all azimuth indices should pass from black to white and vice versa at the same time. The two auxiliary azimuth scales are set by rotating

the main azimuth plate. A setting knob is provided for slow motion of the main azimuth plate. Three indices are provided for setting the degrees and hundredths of the uncorrected azimuth, one (on the right) for ordinary use (with guns); one 4° clockwise from the first for use (with mortars or howitzers) when wind and drift corrections are so large as to cause mechanical interference when using the first; and a third index (10° clockwise from the first) for

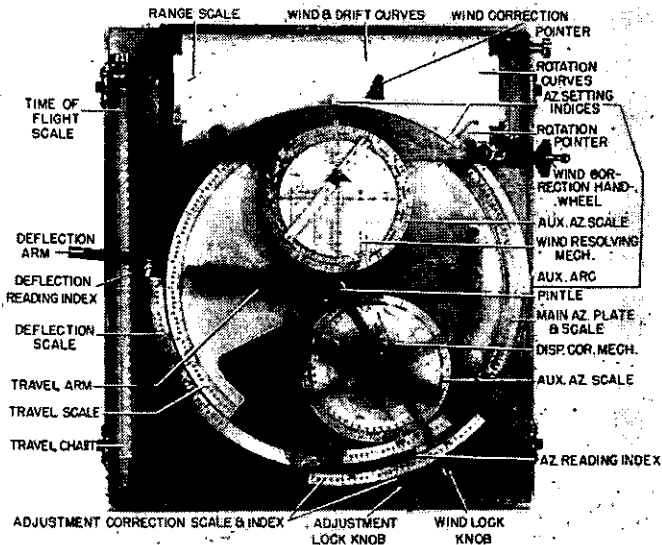

FIGURE 51.—Deflection board M1.

use if the other two should be covered by the sight deflection scale. In any case care must be taken to see that there is proper matching between the black and the white sectors of the main azimuth scales and the auxiliary scales. This may be done by disassembling and reassembling the instrument.

NOTE.—Correct azimuths may be obtained by care in reading or by temporarily coloring the proper sectors with chalk. However, the method by disassembly and reassembly is recommended.

The indices are engraved on an auxiliary arc that is pivoted about the pintle of the board and is used for applying rotation corrections as will be explained later. The azimuth scales graduated in mils are engraved on the reverse side of the degree scales. The main azimuth circle is divided into eight octants of 100 mils each, and one complete turn equals 800 mils. Therefore, when the mil scales are used, the reduction gear must provide an 8 to 1 reduction for the auxiliary azimuth scales, and new correction curves for all factors affecting the pointing must be installed.

c. Wind resolving mechanism (fig. 52).—(1) This board includes a wind component indicator and mechanism for resolving the ballistic wind into its range and deflection components. It is similar in principle to the instrument discussed in paragraphs 80 to 82, but the arrangement of parts has been altered slightly for convenience. The advantage of this mechanism over the separate instrument is that the azimuth of target setting is maintained automatically by normal operation of the board. This mechanism consists of a base plate, a target index, a top plate, and a wind arm.

(a) The base plate is geared to the main azimuth plate and bears one of the auxiliary azimuth scales as mentioned in *b* above. There is engraved on it also an additional azimuth scale graduated in mils with its zero coinciding with the zero of the degree scale.

(b) The target index is fixed to the frame of the board. It is used for setting the hundreds and tens of degrees of the uncorrected azimuth of the target.

(c) The top plate is engraved with cross section lines marked in wind reference numbers. Although the deflection component numbers are marked in the opposite direction from those on the separate instrument, they still represent the same wind effects, that is, numbers smaller than 50 represent a wind from the left blowing the projectile to the right. The top plate is stationary with its normal deflection component line opposite the target index.

(d) The wind arm bears the wind speed scale and the read pointer. It is attached to the base plate by a friction bearing and rotates with that plate in azimuth. It may also be rotated independently of the base plate. It has an index at

each end, one marked *N* and the other *S*, for use in setting the wind azimuth.

(2) The azimuth of the target is always represented from the center of the top plate toward the target index at the bottom. The wind speed may be set by moving the read

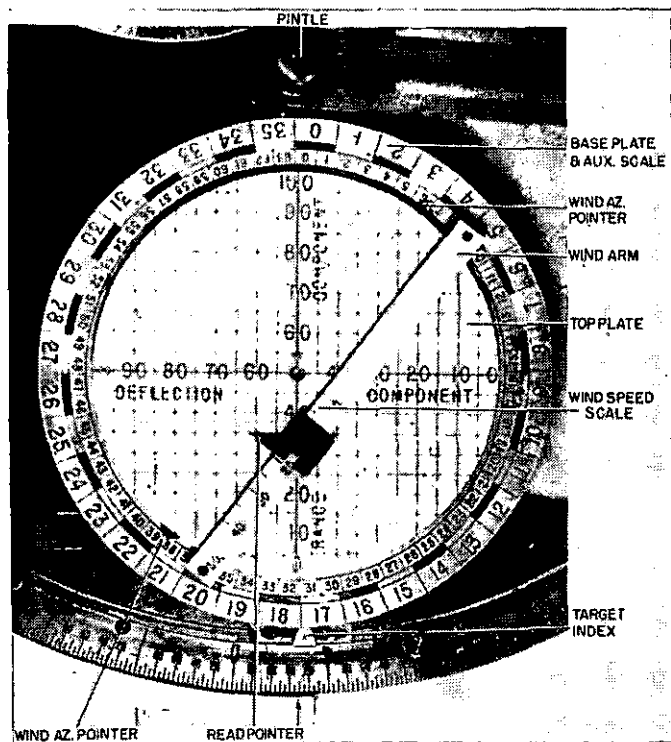

FIGURE 52.—Wind resolving mechanism on deflection board M1.

pointer along the wind arm to that graduation on the wind speed scale. All that remains for proper operation is to set the wind arm to the azimuth of the ballistic wind. Once set, it rotates with the base plate as the target moves in

azimuth, thus maintaining the proper relation between the direction of the wind and the direction of the plane of fire. The rules for setting the wind azimuth are—

(a) Set wind azimuth from zero north.

(b) If target azimuths are measured from the south, use index *S* on the opposite end of the wind arm from the wind speed scale.

(c) If target azimuths are measured from the north, use wind index *N* on the same end of the wind arm as the wind speed scale.

d. Wind and drift computing mechanism.—The wind and drift computing mechanism consists of a ballistic correction chart, a correction arm and pointer, an azimuth reading index, and a clamping mechanism with two lock knobs. The chart bears curves, with effects as abscissas and ranges as ordinates, for the combined effect of wind and drift constructed for each combination of cannon, powder charge, and projectile. The curves are marked in wind reference numbers. The wind correction pointer is pivoted at the pintle of the board and travels in an arc across the face of the chart. Movement is imparted to it by a handwheel. The range lines on the chart instead of being straight are arcs of a circle to accommodate the movement of the wind correction pointer. The arcs are all of the same radius, equal to the distance from the wind correction pointer to its center of rotation. The effects are plotted as angular values along those arcs. The chart is mounted on rollers to permit setting the proper range arc under the wind correction pointer. Separate curves must be constructed for degrees and mills due to the difference in scales used. For a detailed discussion of the construction of these curves, see appendix II. The reading index indicates corrected azimuths on the opposite edge of the azimuth circle from the setting index. It may be clamped to the wind correction pointer by tightening the wind lock knob and the adjustment correction lock knob. When the wind correction pointer is moved from the normal of the curves to the intersection of the proper wind curve and range arc, the reading index is displaced by the amount of the correction for wind and drift.

e. Rotation computing mechanism.—The correction for rotation of the earth is added by displacing the setting index. This causes the azimuth scale to be moved accordingly while the reading index remains stationary. The corrections for rotation are shown on a set of curves at the left of the wind and drift curves on the ballistic correction chart. A rotation pointer is fastened to the auxiliary arc bearing the setting index. When that pointer is moved from the origin line of the rotation curves to the intersection of the proper curve and range arc, the setting index is displaced by the amount of the correction. The rotation correction affects only case III data.

f. Lateral adjustment corrections.—Corrections for lateral adjustment are made by offsetting the azimuth reading index independently of the wind correction pointer. This is done by means of an adjustment correction scale fixed to the arm that carries the reading index and an adjustment correction index and lock knob. When the lock knob is loosened, the reading index and the adjustment correction scale may be moved along the azimuth scale while the adjustment correction index remains locked to the wind correction pointer.

g. Displacement corrector (fig. 54).—This corrector is provided for the purpose of applying a parallax correction to the corrected azimuth from the directing point and indicating that firing azimuth by a separate pointer. The mathematical principles involved are illustrated in figure 53. In that figure *DP* represents the directing point and *G* represents a gun position for which the parallax correction is desired. It is evident that for a given displacement distance *d* the value of the parallax angle *P* depends on the range and the angle α (or β) and that

$$\sin P = \frac{d \sin \beta}{R}$$

The exact solution could be made graphically if the set-up were duplicated to scale on the board. However, this was found mechanically inconvenient, and an approximate solution giving the desired accuracy was adopted. The approximate solution consists of projecting the displacement *d* onto

the line AB , which is perpendicular to the DP —target line, and solving for the right triangle thus formed by the formula $\tan P' = d \cos (\alpha - 90^\circ) / R$. The DP —target line is represented on the board by the line determined by the pintle of the board and the reading index and passing through the

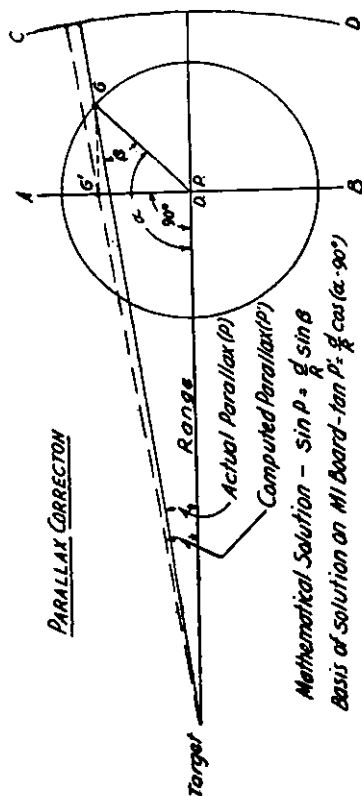

FIGURE 53.—Mathematical principles of displacement corrector.

center of the auxiliary azimuth scale on the base plate. The target is represented at the pintle and the directing point at the center of the base plate. The line AB in the figure is represented on the board by a fixed guide bar. The gun posi-

tion G is on the revolving gun arm which is pivoted at the directing point. This arm is set to the azimuth of the gun position from the directing point by the azimuth pointer on the gun arm and the auxiliary azimuth scale. The auxiliary scale, being driven by the main azimuth plate, is always in orientation. As it rotates it carries the gun arm with it, thus duplicating the varying angle α . Since the distance DP —target on the board is constant it is considered as unity, and the point G is placed at a distance from the directing point proportional to d/R instead of d alone. The rotary movement of G is communicated to G' through a double slide, one slide perpendicular to the guide bar and sliding over G and the other sliding over the first and constrained to move along the guide bar. G' being on the latter side is given reciprocating motion along AB , and the distance d/R is multiplied by the factor $\cos(\alpha-90^\circ)$. An arm called the parallax arm is pivoted at the target position at the pintle and is actuated by the pin representing G' on the top slide. Degrees and hundredths of the azimuth corrected for parallax are indicated on the main azimuth circle (represented in fig. 53 by the arc CD) by an index on the outer end of the parallax arm. This scale being nine times that of the auxiliary azimuth circle on the base plate, the distance $\cos(\alpha-90^\circ) d/R$ must be proportional to $9 \tan^{-1} d/R$. The point G is displaced by means of a scale graduated in terms of $\tan(9 \tan^{-1} d/R)$ and marked in terms of R , the range to the set-forward point. If a series of these range scales is graduated, each for a different displacement, and means provided to bring the proper scale along the gun arm, the mechanism may be made of practically universal application. This is the function of the curve disk. The range scales are plotted along different radii on the disk, each scale for a different displacement between 0 and 500 yards and marked on the periphery. Points of equal range are then joined by a curve, each curve marked with the corresponding range. Range curves are included for values of the parallax angle from zero to a maximum of 2° . The disk is mounted between the base plate and the gun arm. It may be set to bring the proper range scale along the gun arm by revolving it until the displacement distance d shown on the periphery is opposite the displacement pointer on the

gun arm. The disk thereafter revolves with the gun arm and base plate. The point *G* is set by bringing the range pointer attached to the gun arm to the proper range curve. The parallax arm will then indicate on the main azimuth circle the degrees and hundredths of the azimuth corrected for parallax. The curve disk is engraved for operation in degrees only.

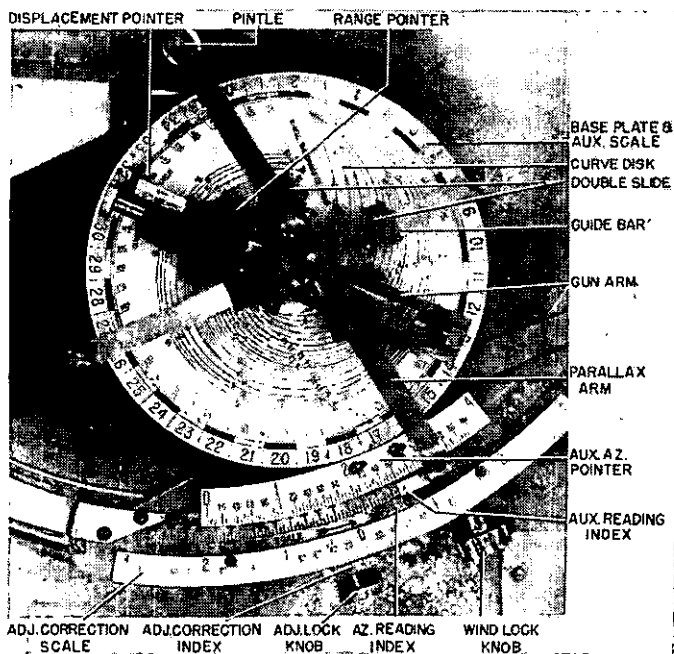

FIGURE 54.—Displacement corrector on deflection board M1.

h. Angular travel computing mechanism.—Corrections for angular travel for use with case II pointing are computed by measuring the rate of angular travel and setting an arm to that rate on a set of curves. An index on the arm then indicates the deflection due to angular travel on the deflection scale.

(1) The rate of angular travel is measured by the travel arm and a circular travel scale. The arm is pivoted at the pintle of the board and attached to the main azimuth plate by a slip friction device. The scale is fixed to the frame at one side of the board. It is graduated to the same scale as the main azimuth circle and marked in reference numbers with a normal of 6.00. After the main azimuth plate is set to the uncorrected azimuth of the set-forward point, the travel arm is set to the normal of the travel scale. When the next uncorrected azimuth is set, the travel arm, moving with the plate, is displaced by the amount of travel during the observing interval (t_0). This travel (θ) is indicated on the travel scale. The travel arm is then reset at the normal.

NOTE.—The angular travel arm can be moved in to the pintle center of the board, decreasing its radial length. It contains also a scale running from 0 to 180. These features were provided in case at a future time it is desired to operate the board with an automatic predictor extrapolator. In such an event, in conjunction with a system of curves, they provide a correction for the error involved in predictions based on the angular travel in place of the linear speed of the target. These features have no present application to the board as used in present systems of fire control and should be disregarded.

The travel curves are carried on two rollers at the same side of the board as the travel scale. They are constructed for values of travel during the time of flight (δ), computed from the formula $\delta = t_f/t_0 \times \theta$. Those values are shown as curves marked with the corresponding values of θ (in reference numbers) with abscissas in terms of δ and ordinates in terms of the time of flight (t_f).

(2) Deflections are indicated by a deflection arm on a deflection scale. The scale is engraved on the arc of a circle whose center is at the pintle of the board. The deflection arm is pivoted at the pintle. When the travel chart is set with the proper time of flight opposite its index and the deflection arm set to the travel curve (θ), the deflection due to travel (δ) is indicated on the deflection scale opposite an index on the deflection arm. Since the abscissas of the travel curves are plotted as linear values at a distance r from the pintle, they are laid off in terms of $r \tan \delta$ instead of δ . Furthermore, since the actual angle through which the deflection arm must be moved from normal to the setting is nine times

the indicated value on the deflection scale, the abscissa scale is actually $r \tan 9\delta$ (or $r \tan (9 t_1/t_0 \times \theta)$). It will be noted that the travel chart as furnished with the board is provided with two scales of ordinates, each for a particular observing interval. Deflection scales are furnished with normals of 3.00, 6.00, and 10.00, so that all gun sights may be accommodated.

i. Application of ballistic and adjustment corrections for case II pointing.—The deflection scale is attached to the arm carrying the azimuth reading index. When that index is displaced, the normal of the deflection scale is displaced by the same amount from the normal of the travel chart. Therefore, when the wind and drift computing mechanism or the adjustment correction mechanism is operated, the corresponding correction is added algebraically to the deflection.

■ 108. ADJUSTMENT.—The adjustment of the board consists of establishing a relationship between all set and read pointers such that proper corrected azimuths or sight settings are obtained when corrections are applied to observed data. The operation is performed as follows:

a. Preliminary adjustment.—(1) Set the rotation pointer on the zero deflection line of the rotation curves. (The zero deflection line is the reference line running through the origin of each set of curves.) If no correction is to be made for rotation of the earth, run the rotation pointer back against its stop and fasten it so that there will be no danger of it being accidentally displaced during operation of the board. (The rotation pointer is not used in case II pointing.)

(2) Set the wind correction pointer on the zero deflection line of the set of wind and drift curves which are to be used. (Some charts furnished contain more than one set of wind and drift curves.)

(3) Set the lateral adjustment correction pointer to normal.

b. To complete adjustment.—(1) *For case III pointing.*—Release the wind lock knob, set opposite the azimuth reading index the same azimuth as that found opposite the azimuth setting index, and tighten the wind lock knob.

(2) *For case II pointing.*—(a) Set the deflection arm to the normal of the travel chart.

(b) Release the wind lock knob, move the deflection scale until the deflection opposite the deflection reading index is normal, and tighten the wind lock knob.

NOTE.—In general, the board must be readjusted when a change is made between case III and case II pointing.

■ 109. OPERATION.—*a. General.*—Two operators are required, whether pointing by case III or by case II. Operator A operates the wind resolving mechanism and the ballistic correction chart and pointers and sets the uncorrected azimuths. Operator B wears a telephone head set connecting him with the azimuth setters or gun pointers at the guns. He operates the lateral adjustment correction mechanism and angular travel device and transmits the corrected azimuths or deflections to the guns. He operates the displacement corrector when that mechanism is used.

b. Case III pointing.—(1) Operator A takes post opposite the ballistic correction chart. He makes the initial settings on the wind resolving mechanism—that is, sets the wind arm to the azimuth, and the wind pointer to the speed, of the ballistic wind. He sets the ballistic correction chart to the range or elevation of the set-forward point and sets the rotation and wind pointers opposite the proper curves. He sets the uncorrected azimuth (as called out by the plotter), hundreds and tens of degrees opposite the target index on the wind resolving mechanism and degrees and hundredths opposite the setting index. Thereafter he keeps the correction chart and pointers set and continues setting the uncorrected azimuths.

(2) Operator B takes post opposite the azimuth reading index. He reads the corrected azimuth to the azimuth setters at the guns. He sets the lateral adjustment correction by loosening the adjustment lock knob, moving the adjustment correction scale (to which is attached the azimuth reading index) until the correction ordered is set opposite the adjustment correction index, and tightening the lock knob. Whenever a new adjustment correction is ordered he incorporates it into the next data, and when those data are sent he calls out CORRECTION APPLIED. When the displacement corrector is used

he performs the following additional duties: Sets the gun arm to the azimuth of the displaced gun from the directing point and turns the curve disk until the distance to the displaced gun is under the displacement pointer; keeps the range pointer set at the range to the set-forward point and reads the corrected azimuth opposite the index on the parallax arm.

c. Case II pointing.—(1) Operator A has the same duties as for case III except that he omits the setting of the rotation pointer.

(2) Operator B takes post opposite the travel chart. After the first uncorrected azimuth is set he sets the travel arm to the normal of the travel scale. Thereafter, as each uncorrected azimuth is set he notes the reading on the travel scale opposite the travel arm and sets that arm back to normal. He sets the travel chart to the time of flight corresponding to the range to the set-forward point and sets the deflection arm to the curve on the travel chart that corresponds to the reading noted on the travel scale. Opposite the deflection reading index he reads the deflection, calling it to the gun pointers at the guns. When a lateral adjustment correction is ordered he applies that correction in the same manner as for case III pointing.

■ 110. CONVERSION FROM DEGREES TO MILS.—*a.* Remove from the board all parts above the main azimuth plate.

b. Reverse the main azimuth circle and the auxiliary azimuth circles.

c. Substitute four gears marked "for mils only" for those marked "for degrees only" and reassemble. Gears that belong on the parallax side of the board are marked *P*; those that belong on the wind side are marked *W*.

d. In assembling, match all indices with sectors of the same color and match the readings on the two auxiliary circles.

e. Replace ballistic chart and deflection scale with those constructed for mils.

NOTE.—No provision is made for applying a parallax correction when operating in mils, the curve disk being engraved for operation in degrees only.

SECTION VII

AZIMUTH ADJUSTMENT SLIDE RULE

■ 111. DESCRIPTION.—*a.* The azimuth adjustment slide rule (fig. 55) is furnished for the purpose of varying an angular adjustment correction according to the elevation in high angle fire. By it an adjustment correction ordered at a particular elevation and in a given zone may be converted into the appropriate correction for any other elevation in any zone. The converted correction may then be applied to the firing data on the deflection board.

b. The instrument is a circular slide rule consisting of two concentric disks and a radial arm called the "runner." The lower disk is larger than the upper; it is graduated logarithmically in absolute values (not in reference numbers) of angular corrections and marked in degrees and hundredths from 0.05° to 2.00° . The upper disk bears a logarithmic eleva-

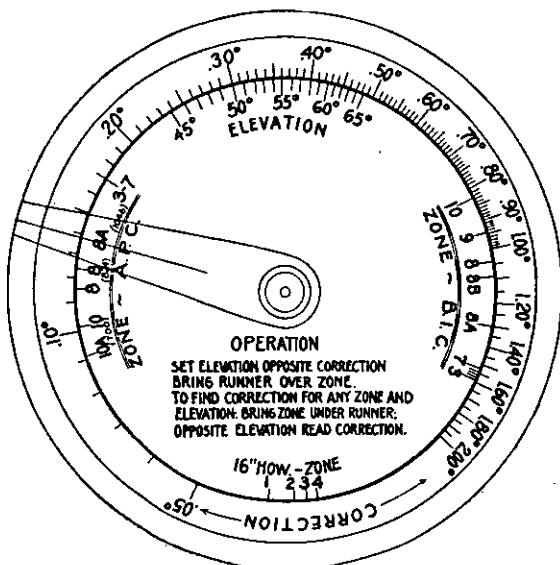

FIGURE 55.—Azimuth adjustment slide rule.

tion scale and several separate scales for zone to zone changes for different combinations of cannon, powder charge, and projectile. These scales are graduated logarithmically in terms of appropriate conversion factors which modify the original correction in the desired manner. The conversion factors are based on the mean cross wind effects as given in the firing tables, the theory being that the adjustment correction should vary as the wind corrections. The runner is pivoted at the common center and is for use in making zone to zone changes.

c. If the correction on the lower disk is placed opposite the elevation being used on the upper disk, the converted correction for any elevation may be read opposite that elevation. If at the same time the runner is placed over the zone being used, on the proper zone to zone scale, the correction may be converted to that appropriate for another zone (on the same scale, that is, for the same cannon) by holding the runner in place and bringing the new zone marking under the runner.

■ 112. OPERATION.—The rule may be operated by the deflection board operator. He notes the adjustment correction ordered and the zone and elevation being used. Let us assume that a mortar battery is firing in zone 8-A using aliquot part charges. The operator hears a correction ordered of "left 0.30°" when firing at 50° elevation. He sets the 50° elevation mark opposite the 0.30° correction mark as shown in the figure and sets the runner over the mark representing zone 8-A, on the A. P. C. scale. He then applies the 0.30° correction on his deflection board. (When using this instrument, the adjustment correction scale on the board should be marked in absolute values instead of reference numbers.) He observes the change in the correction as the elevation changes and keeps the correction set to the nearest 0.05°. Thus when the elevation increases to 53° the operator should change the correction on the board to 0.35°. When the zone changes, the upper disk is moved to bring the new zone marking under the runner. He then reads his new correction opposite the appropriate elevation on the elevation scale and applies it on the deflection board.

CHAPTER 13

SPOTTING SYSTEMS AND DEVICES

	Paragraphs
SECTION I. General.....	113-117
II. Earlier types of spotting boards.....	118-120
III. Spotting board M2.....	121-126
IV. Three-station spotting.....	127
V. Aerial spotting.....	128-135

SECTION I

GENERAL

■ 113. PURPOSE.—In spite of the thoroughness and care used in determining the nonstandard ballistic conditions and applying corrections to the actual range to the target (or set-forward point) to compensate for those conditions, it is yet a fact that we cannot determine those conditions and their effects with sufficient accuracy always to place the center of impact on the target. Therefore, recourse is had to observation of fire or spotting by which we determine the location of the impacts of single shots or the centers of impact of groups of shots with respect to the point upon which fire has been directed. Then by applying the rules for fire adjustment we are able to arrive at an adjustment correction which will move the center of impact closer to the target. (See FM 4-10 for the development of the rules for fire adjustment and their application.) It is reasonable to assume that the necessity for spotting will always exist, and that the accuracy and promptness with which spotting is carried on and the appropriate corrections made are direct measures of the effectiveness of fire and the efficiency of the personnel firing. Since a cannon is pointed in range and in direction independently, range and lateral adjustments are conducted independently. As a consequence spotting is necessary in both range and direction. The actual observations taken to obtain the deviations may be conducted in concert or independently, but the spotting results must give separate range and lateral deviations. The range deviations are determined in linear

units, in yards or percentage of the range, and lateral deviations are usually determined in angular units, in degrees and hundredths or in mils.

■ 114. SPOTTING SYSTEMS.—The spotting system may use one or more terrestrial spotting stations, or an observer in the air, or a combination of terrestrial and aerial observation. A battery should be self-contained in this respect and as nearly as possible independent of outside agencies. A terrestrial spotting station is called axial if the angle battery—target—station is less than 5° , flank if more than 75° , and unilateral if between the two. Properly selected spotting stations will have the same characteristics as properly located observation stations. The requirements are, in order of importance, excellent view of the field of fire, suitable base line if spotting is by the two-station method, proper facilities for communication, noninterference by searchlights, natural or artificial concealment, and protection from enemy fire. In order to meet the requirements of fire adjustment on naval targets, spotting on such targets must have both speed and accuracy. Under ideal conditions both speed and accuracy would be developed to a high degree, but under actual conditions some compromise must be made. Spotting should always be accurate to within one probable error of the guns of the battery, and deviations must be reported in the proper sense. Deviations should be reported within 10 seconds after the splash has occurred. These conditions require simplicity of method and careful training of personnel.

■ 115. SPOTTING OBSERVERS.—*a.* The instrument ordinarily employed by the spotting observer is the azimuth instrument. With it he determines the angular deviation of the splash from the observer-target line. The determination of the angular deviation is made by tracking the target with the vertical cross wire of the instrument until the splash occurs. The instrument is then held stationary and the angular deviation of the splash is read by means of the deflection scale etched on the reticle. (See par. 42*a*(1).)

b. If firing is conducted by salvo, the observer must estimate the center of impact of the group of splashes as seen from his station and make his reading on that point. For

convenience in marking the estimated position of the center of impact, a splash pointer is provided. When the splash pointer has been moved to this estimated position, the deviation is read by means of the deflection scale. The ability to determine accurately and promptly the deviation of centers of impact is gained only by thorough training and experience. Training of spotting observers is one of the most important phases of the development of an efficient spotting system; the failure to realize the difficulties involved and to provide proper means for training and practice is the usual cause of failure of the system.

■ 116. METHODS OF SPOTTING LATERAL DEVIATIONS.—*a.* The spotting of lateral deviations has for its purpose the determination of the direction and magnitude of the deviation of a splash (or center of impact) in angular units from the directing point—target line. The usual procedure is to station an observer at or near the directing point with an azimuth instrument and with communication to the person conducting the lateral adjustment. The observer reads the angular deviation to the center of the splash and transmits it to that person. (The reference number of the deviation gives its direction as well as its magnitude.) The observer or an assistant records the deviations transmitted. Usually the lateral spotting observer may be placed near enough to the directing point to avoid the necessity of making parallax corrections. When case I or case II pointing methods are used, the correction of lateral deviations is sometimes done by a special method called “jumping splashes” (par. 172*d*).

b. It will be noted in the discussion of range spotting in the paragraphs following that in some methods of range spotting the lateral deviation also is determined. However, the lateral deviation may be determined so much sooner independently that this method is ordinarily used regardless of the method of range spotting used, provided the target can be seen from the battery. With long-range armament this will not always be possible, and lateral deviations must be determined from observations taken from distant stations.

■ 117. RANGE SPOTTING METHODS.—*a. Purpose.*—Spotting in range may have as its sole object the determination of the

sense of the deviation—that is, whether the splash is over or short, or its purpose may be to determine both the sense and the magnitude of the deviation. Adjustment of fire by sense alone generally requires the spotting of a greater number of impacts to give a reliable indication of the location of the center of impact than does adjustment by sense and magnitude. For this reason it is particularly applicable to rapid-fire batteries. It is a convenient emergency method for use with larger caliber batteries. Adjustment of fire by the magnitude method is used ordinarily with batteries of 8-inch or larger caliber, of which the slow rate of fire and the expense of ammunition preclude adjustment by sense alone. Range spotting may be conducted using one or two terrestrial spotting stations or by aerial observation.

b. Single-station range spotting.—(1) Range spotting is conducted from a single terrestrial station when only the sense of the deviation is desired, or in emergency for the approximation of the magnitudes of range deviations.

(2) When spotting for sense, the best position of the observer is at a flank station with the line of sight as nearly at right angles to the battery-target line as possible. From this position all but the closest deviations may be spotted accurately, and those so close as to be doubtful may be called hits without detriment to the adjustment. However, use of a flank station is possible only in a special situation and is not a usual service condition.

(3) The next best position for the spotter is an axial station. This is the normal method of spotting for rapid-fire batteries and is less difficult in service than in target practice.

In service, shorts can be seen, overs will probably be lost, and hits will probably be sensed correctly or lost. In target practice the small target does not give a good silhouette background, and it is necessary for rapid-fire batteries to use bilateral or some form of flank spotting to obtain the sensings unless an axial station with an exceptional height of site is available.

(4) When the station is unilateral, accurate spotting even for sense alone is very difficult unless the splash is in line with some portion of the target. The overs and shorts will seldom be silhouetted against the target.

(5) A single axial station may be used for emergency spotting of the magnitudes of range deviations if visibility is good and the height of site is relatively large considering the range.

(6) Attempts have been made to spot the magnitudes of range deviations from an axial station by the use of a depression position finder and a comparison of the range to splash and range to target, but with little success except in special situations where good heights of instrument were obtained. In any case a separate instrument should be used for spotting; the regular observer should not be burdened with the additional duty of spotting. It is quite probable that the best emergency method of range spotting for major caliber batteries under actual battle conditions will be confined to spotting for sense alone.

c. Two-station range spotting.—(1) Spotting for the magnitudes of range deviations is done where possible by two-station spotting, generally called "bilateral." In this method, simultaneous observations are taken on the splash from each of two spotting stations at the ends of a spotting base line to determine its angular deviations from the target as seen from the respective stations. Some form of graphical or mechanical computing device is then used to convert these data into the required measurements of the deviation. (See pars. 118 to 121, incl.)

(2) When spotting is being conducted by this method, the deviations from the target are determined and, since the guns are always pointed in elevation at the set-forward point instead of the target, such deviations will contain the error in the location of the set-forward point. In firing at a fast-moving, maneuvering target, especially when the dead time and the time of flight are long, the error in the location of the set-forward point may be considerable, and serious complications might be introduced into the adjustment of fire. Under those conditions the best procedure would be to correct the deviation as read from the computing device by the amount of the plotter's error, as determined from the actual track on the plotting board with the aid of later observations.

(3) There is a method by which deviations from the set-forward point may be determined directly. This consists of

spotting the azimuths of the splashes and plotting them on an auxiliary plotting board together with the set-forward point as located by the uncorrected range and azimuth. The deviations may then be scaled from the plotting board. This method is much less accurate than the indirect method previously discussed and is not considered satisfactory.

(4) In bilateral spotting, an observer at an axial station reads on the center of the splash and an observer at a flank station reads on the edge of the splash nearest the battery.

SECTION II

EARLIER TYPES OF SPOTTING BOARDS

■ 118. GRAY SPOTTING BOARD, EARLY MODEL (fig. 56).—This board had the spotting stations (S^1 and S^2) plotted to the

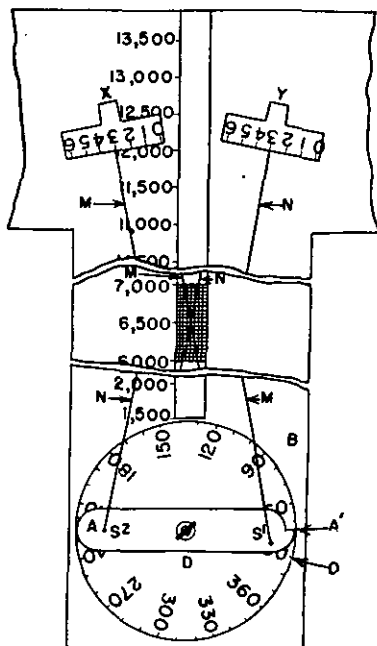

FIGURE 56.—Gray spotting board (early model).

scale of the board on an arm (AA') which was pivoted at the directing point. By means of the azimuth circle (O) and the index (A') this spotting base line was kept set so as to give the proper angular relation between the spotting base line and the gun-target line. A black ruled in squares, 50 yards on a side to the scale of the board, was moved so that its center was at the range to the target. A string from each spotting station was stretched across the center of this target block. When the spotting observer reported the deviation from his station, the string was moved through that arc by means of a splash scale attached to the string. The intersection of the strings then gave the location of the splash with reference to the target. This board was simple to build and operate but could be used only for the particular battery for which constructed and it gave the range and lateral deviations in yards.

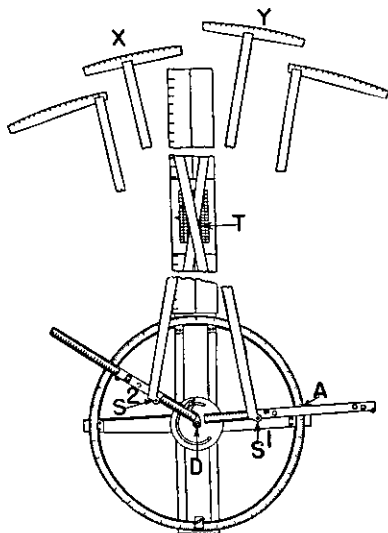

FIGURE 57.—Gray spotting board (modified model).

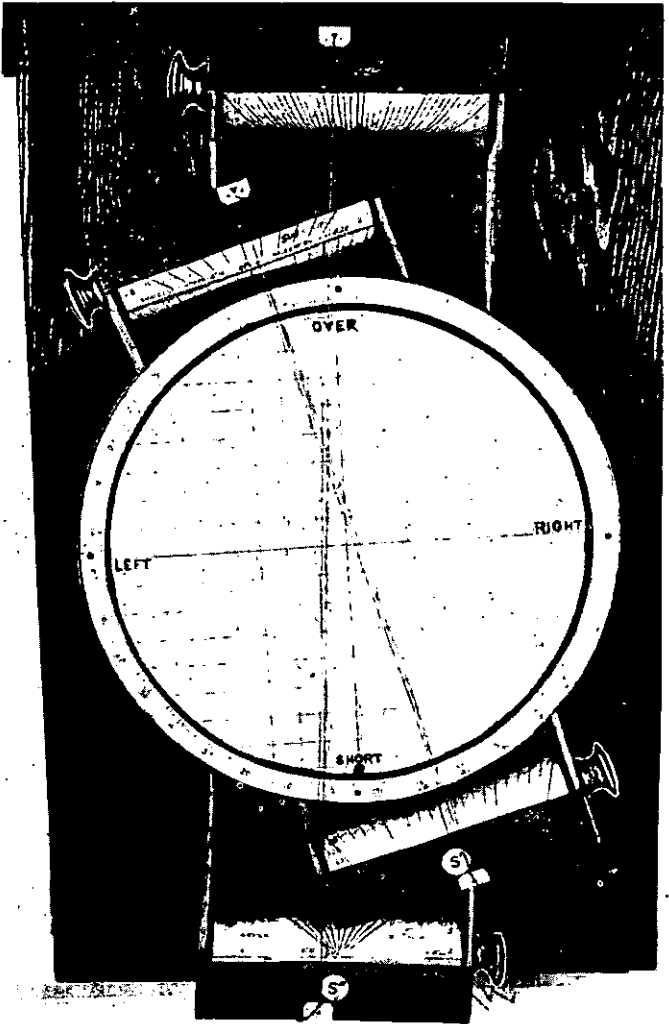

FIGURE 58.—Cole spotting-board.

■ 119. GRAY SPOTTING BOARD, MODIFIED MODEL.—This board is the same in principle and operation as the earlier board. The azimuth circle is of brass and can be rotated. The distances from the directing point to the spotting stations are set on brass arms pivoted at the center of the azimuth circle. These arms are then set at the angle $S^{\circ}DPS^{\circ}$ and locked in that position. Brass arms also replace the strings for plotting the splashes. This board has also the advantages that it can be set up readily for any battery, it is more accurately graduated, and the brass arms are more satisfactory than strings. It does not provide means of converting the deviations into the proper units. The original design of this board and many of the boards in service have the plotting arms attached to the splash scales at the centers of those scales as shown at *X* and *Y* in figure 60. This causes interference in setting some deviations. This interference can be materially reduced by attaching the plotting arms to the inner ends of the splash scales.

■ 120. COLE SPOTTING BOARD (fig. 58).—The Cole spotting board with its auxiliary data device (fig. 59) can be adjusted for any spotting base line and gives very satisfactory results except that these results are deviations in yards and have to be converted into the desired units. The data device is essentially a small scale (1 inch=1,200 yards) relocating board by which the range of the target from each spotting station and the angle between each spotting station target line and the gun-target line are determined. With these data the relative positions of the gun-target line and the two spotting station target lines are set up on the main board, which represents the area around the target on a grid to the scale of 150 yards to the inch. By means of specially constructed protractors at both ends of each spotting station arm the strings representing the lines of sight are offset the amount corresponding to the spots, and the deviations are read at the intersection of the strings.

SECTION III

SPOTTING BOARD M2

■ 121. GENERAL.—The spotting board M2 (figs. 60 and 61) is the standard instrument for determining range and lateral deviations from the target when bilateral terrestrial observation is available. Range deviations may be determined in percent of the range or in yards. When the board is adjusted to determine range deviations in percent, lateral deviations are read in degrees and hundredths; while if range deviations are in yards, lateral deviations also are read in yards.

■ 122. BASIC ASSUMPTIONS.—In figure 60, T represents the target. The spotting stations, S^1 and S^2 , and the directing point are not represented, but direction lines to those stations are shown. In designing the board the following assumptions were made: That as the line of sight from any station moves away from the target it moves parallel to itself; and that, in the vicinity of the target, points of equal range from each station are on straight lines perpendicular to the lines of sight. These assumptions are approximately true for the normal ranges to the target. Suppose the deviations ΔS^1 and ΔS^2 of a splash are reported from the spotting stations. According to the assumptions, the lines of sight to the splash, BS and AS , are parallel to TS^1 and TS^2 , respectively, and BT and AT are perpendicular to those respective lines. S represents the position of the splash.

■ 123. FORMULAS.—In figure 60, if R^1 and R^2 are the ranges from S^1 and S^2 , respectively, the following formulas may be derived (see appendix III):

For range deviations TG :

$$TG = \pm \frac{R^1 \cos T^2}{\sin T} \tan \Delta S^1 \pm \frac{R^2 \cos T^1}{\sin T} \tan \Delta S^2 \quad (1)$$

For lateral deviation GS :

$$GS = \pm \frac{R^1 \sin T^2}{\sin T} \tan \Delta S^1 \pm \frac{R^2 \sin T^1}{\sin T} \tan \Delta S^2 \quad (2)$$

In equations (1) and (2), TG and GS are in linear units corresponding to those used for R^1 and R^2 . The sign of each right-hand member of the equations depends on the direction

in which ΔS^1 or ΔS^2 is measured and must be determined by inspection. In the situation illustrated in the figure, both ΔS^1 and ΔS^2 are negative in range effect, while in lateral effect ΔS^1 is positive and ΔS^2 negative.

Representing TG and GS by the terms ΔR and ΔL , respectively, and dividing by R , we get

$$\frac{\Delta R}{R} = \frac{R^1}{R} \times \frac{\cos T^2}{\sin T} \tan \Delta S^1 + \frac{R^2}{R} \times \frac{\cos T^1}{\sin T} \tan \Delta S^2 \quad (3)$$

and

$$\frac{\Delta L}{R} = \frac{R^1}{R} \times \frac{\sin T^2}{\sin T} \tan \Delta S^1 + \frac{R^2}{R} \times \frac{\sin T^1}{\sin T} \tan \Delta S^2 \quad (4)$$

But $\frac{\Delta R}{R}$ is proportional to the percentage deviation in range,

and $\frac{\Delta L}{R}$ is very nearly equal to the lateral deviation in radians.

The board may therefore be made to read range deviations in percentages and lateral deviations in angular units by giving the platen the proper graduations and setting the disks O (see par. 124 and fig. 61) according to the ratios R^1/R and R^2/R instead of R^1 and R^2 . Provision is made for this on the spotting board.

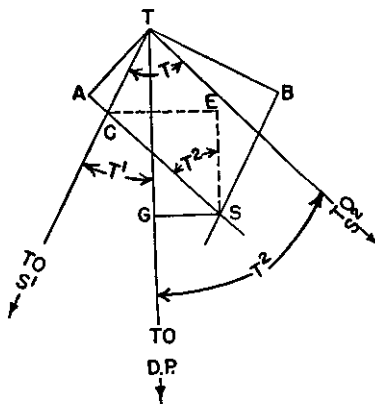

FIGURE 60.—Basic assumptions, spotting board M2.

■ 124. DESCRIPTION AND CONSTRUCTION.—*a.* This spotting board (fig. 61) has a cast aluminum base (A) on the upper end of which is rigidly mounted a deviation grid (B). The center of this grid represents the target (T). The directing point is represented by the center of the orienting disk (D), which is mounted on the lower end of the base. This disk bears two station arms (G) pivoted at its center. The spotting stations are represented by the station targs (H) at the ends of the station arms. They may be set in azimuth and distance from the directing point, thus reproducing the triangle S^1S^2DP . The range to the target is set off by operating the range handwheel (E). This moves the orienting disk along the DP -target line. The range scale (C) is provided for setting off this range. Operation of the azimuth handwheel (F) rotates the orienting disk. If it is rotated until the azimuth of the target is indicated on the azimuth index, the complete situation in the field is set up to a small scale on the board.

b. The parts of the board already described serve to position two spotting platens (J) which are pivoted under the center (T) of the deviation grid. Slots in the platens are engaged in the targs (H) so that any movement of the orienting disk is transmitted to the platens which move about their pivots. This movement is assisted by rollers placed between the platens and the arc (K). When the orienting disk is set at the range and azimuth from the directing point to the target, the inner edges of the platens represent the lines from the spotting stations to the target (lines S^1T and S^2T , fig. 60). Each platen carries a deviation arm (M) the reading edge of which represents the line of sight from one of the spotting stations. It is so attached to the platen that it may be moved laterally across it but is always parallel to its inner edge.

c. A deviation disk (L) is attached to each platen. It consists of a movable inner plate (O), a movable outer range ring (P), and a fixed range index. One side of the inner plate is engraved with a linear range scale about its periphery and a set of curves near its center. The curves are marked in reference numbers of angular deviations corresponding to those on the interior scale of the spotting instrument (the M1910 azimuth instrument). They are constructed by polar coordinates of which the vectorial angle is the range (R^1 or

R^2) and the radius vector is the product of the range times the tangent of the angular deviation. This side of the plate is used to determine the deviations of the splash in yards. When the inner plate is rotated until the range from the spotting station is opposite the range index, and the pointer (N), which is attached to the deviation arm, is opposite the curve corresponding to the observed deviation, the deviation arm (M) is displaced from the line S^1T (or S^2T) by the distance $R^1 \tan \Delta S^1$. The factor $\frac{\cos T^1}{\sin T}$ is supplied mechanically through the movement of the orienting disk and the platen. The intersection of the two arms marks the position S of the splash. This is referred to the deviation grid on which the deviation in yards may be read. The scale of the grid and of the curves is, of course, the same, but is considerably larger than that of the orienting disk and range scale. This difference in scales is made possible by the assumption that the lines of sight from the spotting stations moved parallel to themselves. The other side of the inner plate is used, together with the outer range ring (P), in determining the range deviations in percentages and the lateral deviations in degrees and hundredths. On this side the range scale is logarithmic, as is that on the outer range ring. The range ring is moved until the range R , from the directing point to the target, is set opposite the fixed range index. The plate is then rotated until the range R^1 is set, in this case opposite an index on the outer range ring. The deviation arm is then displaced by the distance $R^1 \tan \Delta S^1/R$. The deviation grid (B) also must be reversed before the deviations can be determined. The ranges R^1 and R^2 are shown on range scales on the inner edges of the platens opposite the indices on the station targets. On the degree side each deviation disk provides for all cases where the range from the spotting station is from one-half to one and one-half times the range from the directing point. The maximum value of R^1 or R^2 that can be set on the yards side of the deviation disk is 30,000 yards.

NOTE.—A spotting board similar to the M2 board may be constructed locally. For use in constructing this improvised board, the Coast Artillery Board, Fort Monroe, Va., supplies a mimeographed description with photographic reproductions of the deviation grid for mounting on the platen, of the gun range scale, of

the range scale for the station arms, of the scales for the orienting disk, of the scales and curves for the elevation disks, and of the assembly drawing. Scales are supplied for operation in mills as well as in degrees.

■ 125. ORIENTATION.—To orient the board, see that the proper scales are inserted in the range scale (C) and the spotting platens (J) and that the proper sides of the deviation grid (B) and deviation disks (L) are up, depending on whether spotting is to be in percent of the range or in yards. Convert the distances from the directing point of the battery to each spotting station into inches at the scale of the board. (The graduations on the station arms are in inches.) Loosen the clamp screws holding the station arms (G) in position and set each station to its proper distance in inches from the directing point. Turn each station arm until its index reads (on the inner azimuth circle of the orienting disk (D)) the azimuth from the directing point to that spotting station. Tighten the clamp screws. By turning the range and azimuth handwheels (E) and (F), the indexes of the orienting disk are made to read the range and azimuth of any target in the field of fire. The board then represents to scale in their proper relative positions, the target, the directing point, and each spotting station.

■ 126. OPERATION.—To use the board to determine longitudinal deviations in percent of the range and lateral deviations in degrees and hundredths, proceed as follows:

a. See that the deviation grid (B) and deviation disks (L) are set with the proper faces up.

b. Keep the orienting disk (D) set to the range and azimuth to the target. (The range and azimuth to the set-forward point as determined on the plotting board may be used for this purpose.)

c. Set the range ring (P) on each deviation disk (L) to read the range from directing point to target.

d. Set the range scale on the inner plate (O) of each deviation disk (L) to the range from that station to the target as shown by the reading of each station target (H) on the spotting platen range scales.

e. Set each deviation pointer (N) to the curve corresponding to the splash reading reported by the spotting observer at that station.

f. On the deviation grid (B) read the range and lateral deviations indicated by the intersection of the deviation arms (M).

g. Two operators are required, each connected by telephone to a spotting observer. One sets the range to the set-forward point and operates the left-hand deviation disk. The other sets the azimuth to the set-forward point, operates the right-hand deviation disk, and reads from the deviation grid the range and lateral deviations indicated by the intersection of the deviation arms.

h. To use the board to determine deviations in yards, the deviation grid (B) and the deviation disks (L) are set up for that purpose, and the procedure is as just described except that the setting of the range from directing point to target on the deviation disks is not required.

NOTE.—When fire adjustment is conducted by the corrections method (par. 139), the deviation grid of the spotting board M2 or earlier or modified types of this spotting board must be graduated in the reverse order of that engraved on the standard grid. This may be accomplished by placing a piece of adhesive tape over the engraved numbers and regraduating the scale from top to bottom with normal (300) in the same position as before. Due to this reversal, the reading in reference numbers now obtained is *not* the deviation but the correction, which, if it had been applied to the impact under consideration, would have given a hit or normal (300) reading. For example, if a shot actually fell over 1.5 percent or at 315 according to the standard deviation grid, it would be read 285 on the modified scale, and 285 is the correction that would have given a hit.

SECTION IV

THREE-STATION SPOTTING

■ 127. **THREE-STATION SPOTTING.**—All the required information for the adjustment of fire in both range and direction may be determined by two-station spotting. However, since spotting of lateral deviations from a single axial station is so simple and rapid, it usually is better, whenever possible (see note), to obtain lateral deviations from a third station that is independent of the bilateral system. There are two advantages to this procedure. One is the ability to secure lateral adjustment more speedily and thereby assist materially in the spotting of range deviations by keeping the splashes on or near the gun-target line. The other is the lessening of

the chances of errors in determining the lateral deviation by making that determination dependent on the observation of only one man. When one of the stations of the bilateral system is an axial station, the same advantages will be gained by taking the reading of the axial observer independently for the lateral deviation.

NOTE.—For long range armament, splashes cannot always be seen from a station at or near the battery.

SECTION V

AERIAL SPOTTING

■ 128. **PURPOSE.**—The purpose of aerial spotting is to determine the range deviations of the impacts or centers of impact of a firing. It may include also the determination of the lateral deviations when that information cannot be acquired by terrestrial observation. Aerial spotting may in an emergency be the only available means of obtaining data on which to base the control of fire. The employment of such an emergency system permits the use, with some degree of effectiveness, of seacoast guns under conditions which, due either to poor visibility or to the long range of the guns themselves as compared to the maximum range of terrestrial observation, make it impossible to use any standard method of position finding. Such a system of fire control is described in paragraphs 144 to 148, inclusive.

■ 129. **SPECIAL INFORMATION FURNISHED BY AERIAL OBSERVER.**—In addition to the information as to the fall of shots, the aerial observer should give the battery commander any information which will assist in the efficient conduct of fire. This should include—

a. Information concerning the enemy's formation and maneuvers affecting the adjustment of fire.

b. Information concerning any impending interruption of observation, giving reasons for and probable duration of the interruption.

c. A report on the effectiveness of fire.

■ 130. **MEANS OF OBSERVATION AVAILABLE.**—Aerial observation may be conducted from aircraft, either lighter than air or heavier than air.

■ 131. COORDINATION.—In order that full advantage may be taken of aerial observation and coordinated effort insured, the following preparations are necessary:

a. Thorough training of personnel of the battery in the methods and instruments used.

b. Establishment of an adequate communication system and training of personnel in its use.

c. Personal conferences between the battery commander and the observer to discuss the mission of the battery, the method of fire, and the method of communication to be used. During the firing the observer should be kept informed as to any changes in the mission of the battery. Upon the completion of the mission or when firing is interrupted for a considerable period of time, the commander of the firing unit should recall the observer.

■ 132. COMMUNICATION.—The normal system of communication between a captive balloon and a firing unit is by telephone. Between other aircraft and a firing unit the normal system is two-way radiotelephone.

■ 133. MEASUREMENT OF DEVIATIONS.—No satisfactory device for measuring deviations by aerial observation has been developed. It is necessary for the observer to estimate the magnitude of the deviation, basing his estimate on a comparison with known distances such as the length of the ship on which the battery is firing. In spite of the lack of instrumental aid, aerial observers can with training develop their abilities to a satisfactory degree of accuracy.

■ 134. UNITS USED IN REPORTING DEVIATIONS.—When the estimated magnitudes of deviations are reported, they should be reported as follows:

a. To the nearest 100 yards, when 100 yards or greater.

b. To the nearest 50 yards, when between 50 yards and 100 yards.

c. As "target," when less than 50 yards.

■ 135. METHODS OF REPORTING DEVIATIONS.—a. *Battery target method.*—If the aerial observer can determine the battery target line, he may report the deviations as over or short and, if desired, right or left of the target, giving the magnitude of each deviation when possible. (See par. 134.) This method

finds limited use because the conditions under which aerial spotting is necessary are such as to make it generally impracticable for the aerial observer to report deviations with respect to the battery target line. (See par. 128.) It might be used when aerial spotting supplements terrestrial spotting, as conditions of visibility which permit terrestrial spotting probably will permit the aerial observer to determine the battery target line.

b. Clock method.—(1) *Report of deviations.*—In this method the deviations are reported in polar coordinates, one coordinate being the direction of the target, splash line from the course of target line, and the other the distance of the splash from the target. The observer reports the deviations as they would appear on the face of a clock laid over the field of fire with the center at the target and the 12 o'clock–6 o'clock line along the course of the target, with 12 o'clock ahead and 6 o'clock astern. Directions are reported first, in hours of the clock to the nearest hour; distances are reported last, in units as indicated in paragraph 134. An observer's clock is shown in figure 62. It consists of a dia-

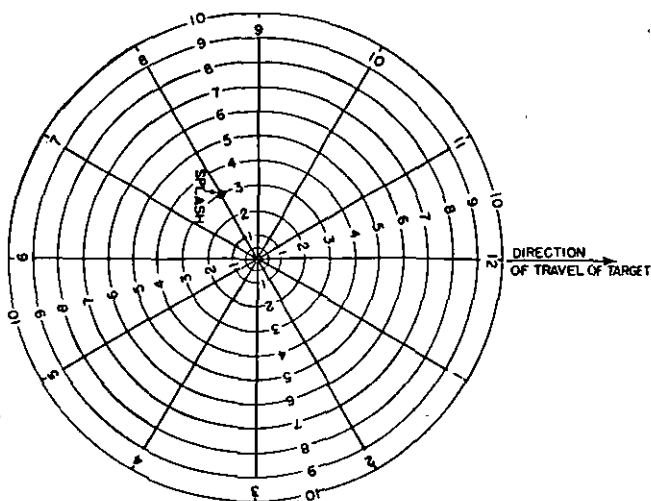

FIGURE 62.—Aerial observer's clock.

gram of a clock face with connective range circles. The radius of the smallest circle is 50 yards; that of the next circle is 100 yards, thereafter the radii of successive circles increase by 100 yards. The reported deviation of the splash shown in figure 62 should be "eight o'clock, three hundred." To assist the observer in the rapid conversion of splashes into clock code, it may be desirable to provide him with one of these clocks.

NOTE.—An alternate reference line for reporting the directions of the splashes is magnetic north. Use of this line, however, complicates the system and is not recommended.

(2) *Conversion of polar coordinates to range and lateral components.*—If deviations are reported in polar coordinates, they must be transformed in the battery plotting room into the corresponding range and lateral components. To do this a special device is necessary. It consists of a clock face mounted on a grid. (See fig. 63.) The clock face is a representation of that visualized by the observer, suitably marked. The grid is a representation of the field of fire about the target which is located at its center. It bears horizontal and vertical lines constructed to the same linear scale as the clock distances. The central vertical line represents the battery target line. The clock is oriented on the grid by setting off the angle between the reference line (the 12 o'clock—6 o'clock line) and the battery target line on the grid. The reported deviation is then marked on the clock and the range and lateral components read from the grid. In the situation shown in figure 63, the angle battery-target-course was determined from the plotting board to be 120° . The clock is shown oriented for this angle. The deviation reported as "eight o'clock, three hundred" may then be converted into "short 300" and "line."

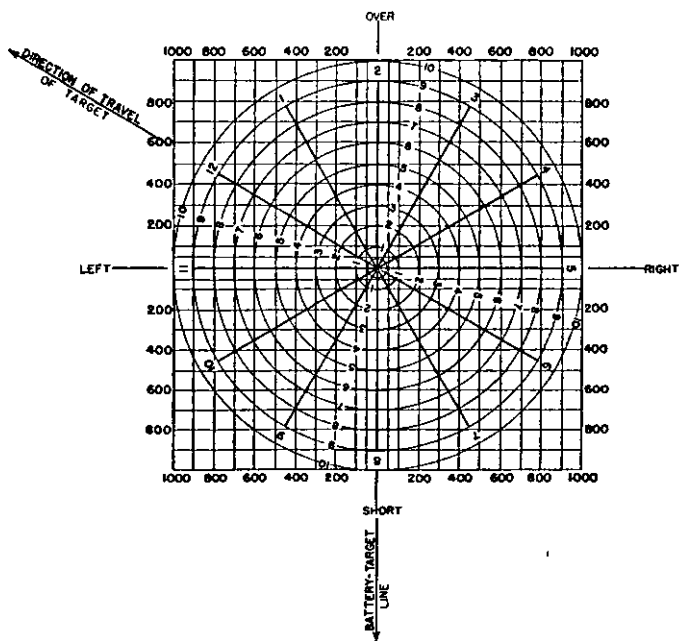

FIGURE 63.—Relocation clock used in plotting room.

CHAPTER 14

FIRE ADJUSTMENT DEVICES

	Paragraphs
SECTION I. Fire adjustment board M1.....	136-139
II. Bracketing adjustment chart.....	140-142

SECTION I

FIRE ADJUSTMENT BOARD M1

■ 136. PURPOSE.—The fire adjustment board M1 (fig. 64) is the standard instrument used for the adjustment of fire by the magnitude method. In order to take full advantage of the rules for fire adjustment by this method, the person adjusting fire must be able to consider together the deviations of any or all of the shots already fired. If all those shots have not been fired with the same adjustment correction, their deviations cannot be considered together until they have been converted into the deviations that would have occurred if the shots had been fired with the same adjustment correction. Because of lack of time this conversion cannot be done arithmetically. The fire adjustment board solves this problem graphically. It provides means for plotting the reported deviations in such a manner that they are shown on the board in the same relation to each other and to the target that they would have had if all the shots had been fired with no adjustment correction. With the deviations so plotted, the stripped center of impact of any desired number of previously fired shots or salvos may be determined by inspection and the proper adjustment correction ordered. The board further provides a permanent record of the adjustment.

■ 137. DESCRIPTION.—The board consists of a wooden drawing board mounted on a metal frame 19 by 24 inches in size. A metal T-square rides in a groove at the left edge of the metal frame and carries a metal slide that can be moved to the left or right. This slide carries a metal scale graduated in *reference numbers of percentage* of the range with 200 on the left, 400 on the right, and 300 (the normal) in the middle. The scale of graduations is 1 inch=1 percent, or 10 units. The least

reading is $\frac{1}{10}$ of 1 percent, or 1 unit. (Due to the reduced scale of figure 64, the unit graduations are not shown.) At the top of the board is fastened a slide rule for converting deviations in yards into deviations in percent of the range. A sheet of

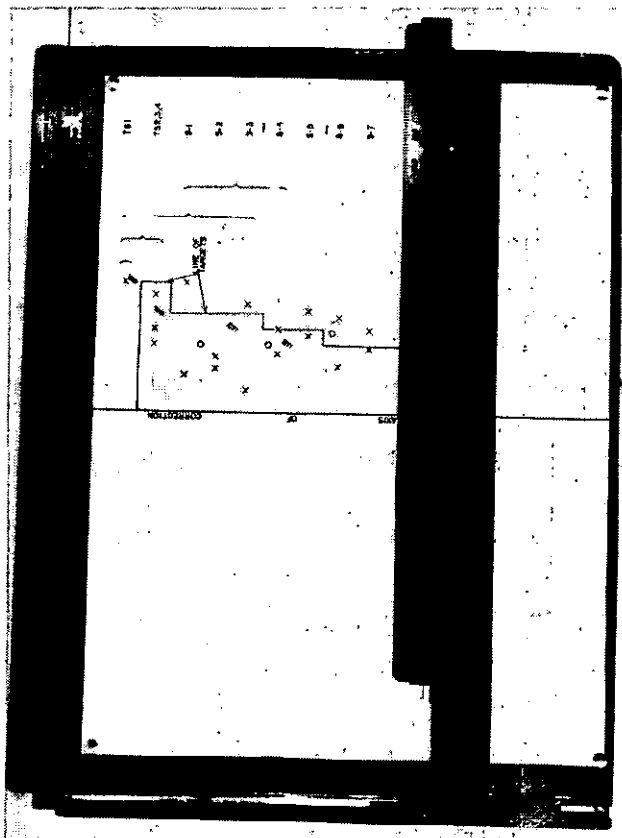

FIGURE 64.—Fire adjustment board M1.

cross section paper (10 divisions to the inch) is mounted on the face of the board. In the absence of an arsenal made board, one can easily be improvised. Any wooden drawing

board can be used. No T-square is necessary; a separate scale graduated in the same manner as the scale on the T-square is sufficient. An ordinary Mannheim slide rule can be used to convert yards to percent of range.

■ 138. OPERATION WHEN STANDARD METHOD OF FIRE ADJUSTMENT IS USED.—*a.* A piece of cross section paper, properly graduated, is fastened to the board so that the horizontal lines are parallel to the blade of the T-square. A heavy pencil line is drawn over that heavy vertical line which is nearest the center of the board. This line is called the "axis of correction." Time may be plotted vertically at any convenient scale, or shots (or salvos) may be plotted at equal vertical intervals. Except where fired with different adjustment corrections, all shots of trial fire are usually plotted on the same horizontal line.

b. To begin the adjustment, bring the reading edge of the scale on the T-square just below the horizontal line on which the trial shots are to be plotted, with the normal of the scale (300) on the axis of correction. Each deviation of the trial shots or trial salvo is plotted in reference numbers with a cross (x). A center of impact of four shots is indicated by a small circle. To determine the correction as a result of trial fire, the normal of the scale is brought to the center of impact of the trial shots, and the adjustment correction is read on the scale at the axis of correction. A check mark is made to indicate the position of the normal of the scale, that is, the center of impact of the trial shots, and the amount of the correction ordered is written above it. Just below this horizontal line a line, called the "line of targets," is drawn from the axis of correction horizontally to a point below the check mark and then downward.

c. When fire for effect begins, the operator checks off with an *S* each salvo as fired. He brings the normal of the scale to the line of targets and plots with a cross (x) on the proper horizontal line each deviation as received. If a correction is made after the impacts of the first four shots (or the salvos comprising them) have been plotted, the normal of the scale is brought to the center of impact (o) of both trial fire and fire for effect, and the correction is read as the axis of correction. If some crosses indicate single impacts and others

salvos, this fact must be considered in determining the position of the center of impact. Crosses for impacts of salvos are marked with an exponent equal to the number of shots in the salvo. Under certain conditions trial fire is not considered in determining the second correction. In that case the normal of the scale should be placed at the center of impact of the shots of fire for effect only, and the correction should be read as before. As soon as the correction is ordered, a check mark is made at the new position of the normal of the scale, and the amount of the correction ordered is written above it. The group of impacts on which a correction was based should be indicated by a parenthesis or bracket. Since fire is not delayed for the purpose of applying the correction, a record must be made of the shot or salvo on which the correction is first applied. This is shown by placing a horizontal mark just above the shot or salvo number on the side of the chart. Meanwhile the line of targets is continued downward, and the impacts of all shots fired with the original correction are plotted from it. When it reaches the position of the horizontal line marking the first shot fired with the new correction, it is again drawn horizontally to a point under the new check mark and finally downward again beneath the check mark.

d. This procedure is continued throughout the firing, additional corrections being made as desired to keep the line of targets on the center of impact of the preceding shots. Impacts are always plotted from the line of targets, noting that the line of targets and the axis of correction coincide until the first correction is applied. All corrections are read opposite the axis of correction which remains fixed. All shots fired with the same adjustment correction should be plotted from the same position of the line of targets. This operation places all plotted impacts on the same basis with respect to the axis of correction; that is, places them all where they would have fallen had no adjustment correction been applied. Therefore, in making corrections, as many of the impacts may be considered as the rules for adjustment of fire call for in each case.

NOTE.—The fire adjustment board may be adapted to use for lateral adjustment by substituting the proper scales on the board. The use of a fire adjustment board when adjusting laterally from an axial station is exceptional.

■ 139. OPERATION WHEN CORRECTIONS METHOD OF FIRE ADJUSTMENT IS USED (see FM 4-10).—*a.* A piece of cross section paper is fastened to the board in the same manner as in paragraph 138*a* and every tenth vertical line—that is, each whole percent line—is numbered each way from the center, 300, 290, 280, etc., to the left and 310, 320, etc., to the right. Numbers should be placed at the top and should be repeated on horizontal lines about every 2 inches below the top. An axis of correction line is *not* used.

b. To begin the adjustment, bring the reading edge of the scale on the T-square just below the horizontal line on which the trial shots are to be plotted with the normal (300) on the 300 line of the chart. (Until a correction is made, the 300 line of the chart is the line of targets and the scale is not absolutely necessary.) Each correction, as received from the spotting board as modified, of the trial shots or trial salvos is plotted in reference numbers with a cross (x) as in paragraph 138*b*. When a percentage correction is necessary, the operator makes the usual check mark (✓) and reads the correction *from the chart* at the top of the chart or at the nearest set of numbers above the check mark. At this time it is not necessary to move the scale, and the possibility of reading back to the wrong line (which may be done when operating as described in paragraph 138*b*) is eliminated. When a shot or salvo has been fired which carries the correction ordered, a new line of targets is drawn downward below the check mark at the proper place and the 300 mark on the scale brought to this new line. Horizontal lines connecting lines of targets, brackets to show shots considered, and other conventions are used as in the method described in paragraph 138*b*.

c. The corrections method is particularly well suited for the lateral adjustment of fire. The normal on the chart can be made to read 200, 300, 3.00, 6.00, 10.00, or any normal desired. If the azimuth instrument, M1910A1, is used, the readings on the deflection scale *are* corrections. If any other instrument is used, rights and lefts can be shown on the scale itself so that corrections are plotted on the chart; or deviations can be plotted on the chart to the right and to the left and the numbers on the chart reversed so that corrections

are read. Another important adaptation is that the scale may be graduated in degrees for use with the azimuth instrument, M1910A1, the lateral corrections plotted in degrees, and the chart made to read corrections in mils or reference numbers based on mils.

SECTION II

BRACKETING ADJUSTMENT CHART

■ 140. GENERAL.—*a.* The bracketing adjustment chart provides a rapid and accurate means of determining and recording graphically the necessary range adjustment corrections for fire for effect when using the bracketing method of adjustment. It does not permit the plotting of stripped deviations; therefore, in using the chart, only those shots that have been fired with the same adjustment correction may be considered together in determining a correction.

b. The chart is based on the over-short rule (see FM 4-10), which is expressed by the equation

$$C \text{ (correction)} = \frac{S - O}{2(S + O)} \times F$$

where O = the number of overs
 S = the number of shorts
 F = the value of the fork (four probable errors)

The fork (F) may be expressed in tenths of 1 percent of the range or in yards. The correction (C) will be given in the same units as are used for the fork.

c. The chart is usually made up to give corrections in percentage of the range for two reasons: first, the corrections are then expressed in the same reference numbers as are used on the percentage corrector and the fire adjustment board; and, second, the value of the fork in yards for any particular combination of powder charge and projectile varies with the range but usually approximates a fixed percentage of the range. A single chart giving corrections in percentage of the range will ordinarily serve over wide range limits, whereas if the chart gives the corrections in yards it is accurate only for the range for which it was constructed.

d. The operator of the chart receives the reports of the overs (O), shorts (S), and hits (H) from the spotting section, plots the graph from those deviations, and determines the correc-

tion. The corrections read from the chart are the corrections called for by the shots being considered at the moment. In order to get the proper reference number for use on the percentage corrector, the operator of the chart must add the correction determined on the chart algebraically to the adjustment correction then being used and transmit the resultant (net) correction to the operator of the percentage corrector. For example, if the correction being used as a result of trial fire is 308 (normal 300) and the first correction as a result of fire for effect is determined to be down 6, the proper reference number for use on the percentage corrector is $308-6=302$. This computation may be made and the record of corrections may be kept conveniently on the correction record at the right of the chart.

■ 141. CONSTRUCTION.—The chart consists of a piece of paper of convenient size on which has been drawn a series of equally spaced vertical and horizontal lines, forming a grid, and a diagonal line extending from the upper left to the lower right hand corner. Each vertical line corresponds to a given number of overs and each horizontal line to a given number of shorts. The diagonal line represents the line of zero corrections and separates the chart into halves; all corrections indicated in the upper half are down corrections and should be subtracted; all corrections indicated in the lower half are up corrections and should be added. The grid may be considered as a system of rectangular coordinates, in which the upper left hand corner is the origin, the X coordinates are overs, and the Y coordinates are shorts. For any combination of overs and shorts, that is, for each intersection of vertical and horizontal lines, there is one, and only one, adjustment correction called for by the over-short rule. The adjustment correction corresponding to each intersection may be computed and indicated on the chart in the desired units. The notations listed in *a*(2) below should then be entered on the chart before it is ready for use in adjustment of fire. There are two types of chart, the grid type and the ray type, differing slightly in construction.

a. Grid type.—Figure 65 shows a grid type chart constructed for a particular combination of powder charge and projectile which develops a probable error of 0.75 percent of

the range (fork=3.0 percent). The corrections are indicated in tenths of 1 percent.

(1) A grid is constructed to a convenient scale and a diagonal line is drawn in. The number of vertical and horizontal lines should be sufficient to cover the maximum number of shots that it is desired to consider at one time; ten of each will generally be sufficient. A convenient scale to use is 1 inch=2 overs (or shorts).

(2) The following notations are inserted on the chart as shown in figure 65:

Over (across the top).

Short (along the left side).

The value of the fork (in the upper right hand corner, expressed in the same units as the corrections).

Correction minus (in the upper half).

Correction plus (in the lower half).

(3) Using the formula given in paragraph 140, the correction corresponding to each intersection of vertical and horizontal lines is computed and entered in the appropriate place on the chart. The necessary data for the construction of the chart shown in figure 65 are given in the following table:

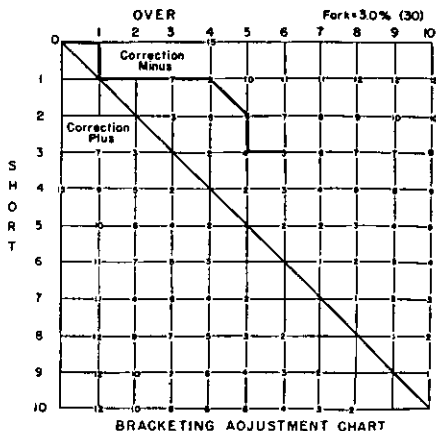

CORRECTION RECORD	
NORMAL	300
1st Correction	_____
Net	_____
2nd Correction	_____
Net	_____
3rd Correction	_____
Net	_____
4th Correction	_____
Net	_____

FIGURE 65.—Bracketing adjustment chart, grid type.

S	O	$\frac{S-O}{2(O+S)}$	F	C	S	O	$\frac{S-O}{2(O+S)}$	F	C
3	1	0.25	30	7	8	3	0.23	30	7
3	2	.10	30	3	8	4	.17	30	5
4	1	.30	30	9	8	5	.11	30	3
4	2	.17	30	5	8	6	.07	30	2
4	3	.07	30	2	8	7	.03	30	1
5	1	.33	30	10	9	1	.40	30	12
5	2	.21	30	6	9	2	.32	30	10
5	3	.13	30	4	9	3	.25	30	7
5	4	.06	30	2	9	4	.19	30	6
6	1	.36	30	11	9	5	.14	30	4
6	2	.25	30	7	9	6	.10	30	3
6	3	.17	30	5	9	7	.06	30	2
6	4	.10	30	3	9	8	.03	30	1
6	5	.05	30	2	10	1	.41	30	12
7	1	.38	30	11	10	2	.33	30	10
7	2	.28	30	8	10	3	.27	30	8
7	3	.20	30	6	10	4	.21	30	6
7	4	.14	30	4	10	5	.17	30	5
7	5	.08	30	2	10	6	.13	30	4
7	6	.04	30	1	10	7	.09	30	3
8	1	.39	30	12	10	8	.06	30	2
8	2	.30	30	9	10	9	.03	30	1

This tabulation, as listed, gives values of corrections for intersections in the lower half of the chart. If the coordinates (overs and shorts) are reversed, the tabulation will give values for intersections in the upper half. As an example of entering the corrections on the chart, consider the intersection $X=3$ overs, $Y=6$ shorts. From the tabulation, the correction 5 should be entered at that intersection. The same correction is appropriate for the intersection $X=6$ overs, $Y=3$ shorts (marked by the end of the graph in fig. 68), in the upper half of the chart.

b. Ray type.—Figure 66 shows a ray type chart constructed for a particular combination of powder charge and projectile which develops a probable error of 50 yards (fork=200 yards) at a particular range. The corrections are indicated in yards. This type of chart differs from the grid type only in the manner of indicating the correction. Instead of marking the appropriate correction at each intersection, rays indicating

the corrections in the desired amounts are constructed on the chart, and the value of the correction corresponding to a particular intersection is determined by noting the ray that passes closest to the intersection (or by interpolating between the two closest rays).

(1) The grid is constructed in the same manner as for the grid type chart.

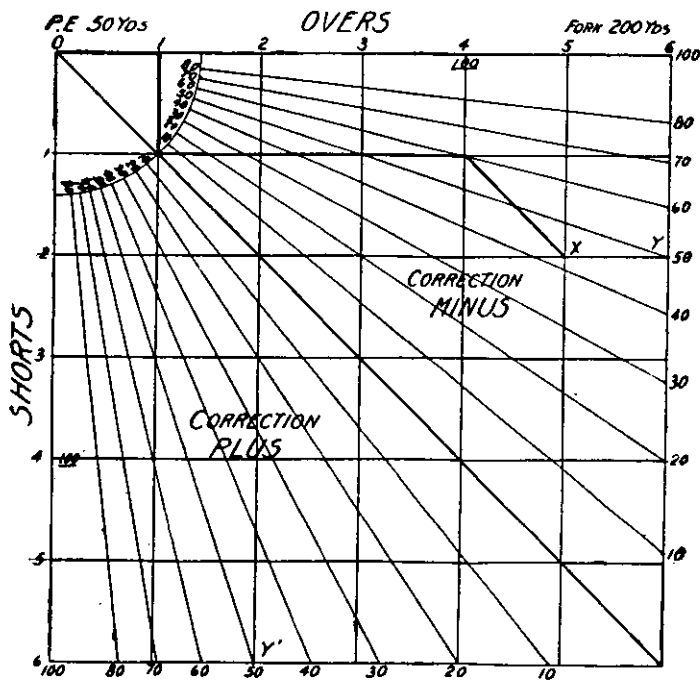

FIGURE 66.—Bracketing adjustment chart, ray type.

(2) The same notations are inserted as for the grid type chart. In addition, the ranges for which the chart is sufficiently accurate should be shown.

(3) Using the formula given in paragraph 140, in the form

$$O = \frac{F-2C}{F+2C} \times S$$

the necessary data for constructing the rays indicating the corrections are computed and the rays are constructed. In this case, the values of the corrections that it is desired to indicate on the chart are known, and it is only necessary to determine any set of coordinates for which each of the corrections is appropriate. In order to assure the greatest possible accuracy in construction, it is best to determine the two largest coordinates on the chart for which each correction is appropriate. The necessary data for the construction of the chart shown in figure 66 are given in the following tabulation:

F	C	$\frac{F-2C}{F+2C}$	S	O
200	10	0.82	6	4.9
200	20	.67	6	4.0
200	30	.54	6	3.2
200	40	.43	6	2.6
200	50	.33	6	2.0
200	60	.25	6	1.5
200	70	.18	6	1.1
200	80	.11	6	.7
200	100	.00	6	0

(4) With these data, rays may be constructed from the origin to the points represented by each set of coordinates determined, and the rays may be marked with the appropriate correction. Coordinates for corresponding rays in the upper half of the chart may be determined by reversing the coordinates in the tabulation for the lower half. As an example of the construction of rays, consider the ray for a correction of up 50 yards. From the tabulation, the coordinates are $X=2.0$ overs, $Y=6$ shorts, indicated by the point Y' in figure 66. The ray should be drawn from the origin to the point Y' . The ray for a correction of down 50 yards should be drawn to the point Y , the coordinates of which are $X=6$ overs, $Y=2.0$

shorts. To construct rays for corrections in terms of percentage of the range, substitute for F and C the values of each in tenths of 1 percent and make computations as before.

■ 142. OPERATION.—Both types of chart are similarly operated. The procedure consists of drawing on the chart a graph of the deviations of a series of shots fired with the same adjustment correction, in the order in which they are reported, starting from the origin. Overs are drawn along a horizontal line, shorts along a vertical line, and hits (being considered as both over and short) along a diagonal. The correction called for by that series is then determined by noting the appropriate correction for the intersection at which the graph stops. In determining whether or not to apply a correction, the operator should be guided by the rules for fire adjustment as given in FM 4-10. The operator adds the correction algebraically to the adjustment correction then being used and transmits the net correction to the operator of the percentage corrector. If desired, a form may be made at the right of this chart, as for the grid type chart shown in figure 65, for convenience in making the computations and keeping the record of corrections. As an example of operation, consider the situation illustrated in figure 65. Let us assume that a four shot salvo of trial fire gave a correction of 314. The first salvo of fire for effect was reported O—S—O—O (3 overs and 1 short). The operator of the chart draws the heavy lines shown on the chart, ending the graph at the intersection $X=3$ overs, $Y=1$ short. The next salvo is reported O—H—S—O, which the operator records as shown, continuing the graph to the intersection $X=6$ overs, $Y=3$ shorts. (A hit is counted as one over and one short.) At this point the chart indicates a correction of down 5. The proper reference number for use on the percentage corrector is $314-5=309$. The graph may be continued, if desired, for any further salvos fired with the adjustment correction of 314. As soon as the operator receives spots on salvos fired with the new correction (309), he should start a new graph either on a new chart or on the same chart with pencil of another color. The procedure for any further firing is the same as for the first series.

CHAPTER 15

AERIAL FIRE CONTROL

	Paragraphs
SECTION I. General.....	143
II. Functioning of an aerial fire control system.....	144-148

SECTION I

GENERAL

■ 143. GENERAL.—*a.* Methods of locating naval targets and controlling fire thereon by aerial observation are in process of development. Fire control by such methods should be resorted to only when it is impossible to use a standard position finding system. Aerial fire control is necessary to allow the use of long range guns to the full extent of their range and may of necessity be resorted to for emergency control of fire at shorter ranges under adverse conditions of visibility from terrestrial stations. The method to be used depends on the locality, the equipment at hand, and the skill and ingenuity of the observer. Methods which require the airplane to fly over the target or within the range of enemy antiaircraft artillery are not considered suitable. No satisfactory method involving the use of special instruments in the plane and at the battery has been devised. Any method used involves in general the plotting of a track on a plotting board by means of reports from the aerial observer as to the approximate position, course, and speed of the target; predictions based on these reported data; firing on the target; and correction of the data as a result of the reports of deviations made by the observer.

b. Some of the methods which have been used for initial location of a target are—

(1) The grid method, in which two identical charts with grids are used, one in the aircraft and one at the firing battery.

(2) The midway point method, in which the aircraft is located by observers on the ground at a signal when the aircraft is halfway to the target. This method has not been found satisfactory.

(3) The depression angle method, in which the aerial observer determines the range to the target by observing the depression angles of battery and target from his position at a known altitude. This method has not been found satisfactory.

(4) The resection method (par. 145) which has been found reasonably satisfactory.

(5) The dead reckoning method (par. 145) which has been found reasonably satisfactory.

c. A method of procedure in conducting and adjusting fire is described in paragraphs 146 and 147.

SECTION II

FUNCTIONING OF AN AERIAL FIRE CONTROL SYSTEM

■ 144. GENERAL.—Fire control by this method presupposes that the target is not visible from the shore stations, that visibility will permit an aerial observer to observe the target without approaching inside the limits of antiaircraft fire, that the aircraft is not visible from the shore stations while observations are being made on the target, and that the only information concerning the location or movement of the target and the fall of the shots will come directly from the aerial observer by radio. This system requires a high degree of coordination between the aerial observer and ground personnel, first, in the initial location of the target and, second, in the conduct of fire.

■ 145. INITIAL LOCATION OF TARGET.—*a. General.*—It is necessary for the aerial observer to locate the target initially so that the firing battery may place a shot within visual aerial spotting distance therefrom. Under ordinary conditions this distance should not exceed 2,000 yards. Two satisfactory methods for accomplishing this are explained in *b* and *c* below. They are called the "resection method" and the "dead reckoning method."

b. Resection method.—This method is applicable only in particular localities where there are prominent terrain features, such as islands or permanent aids to navigation, situated in the defended water area and visible from the aircraft while observations are being made on the target. The pilot alines the aircraft with the target and some fixed reference point in the defended area. From this position the

aerial observer determines the magnetic azimuth of the line established and the time of observation. Similar data are determined for another fixed reference point. The information thus obtained together with the estimated course and speed of the target is sent by radio to the firing battery. The initial location of the target on the plotting board is obtained by drawing rays at the reported magnetic azimuths from the fixed reference points after a correction is applied to allow for the travel of the target between the times of observation.

c. Dead reckoning method.—(1) *General.*—The dead reckoning method of initial location of the target may be resorted to when there are no suitable terrain features in the defended area to permit the use of the resection method. The problem resolves itself into two phases—first, locating the aircraft at the times of observation and, second, locating the target with reference to the aircraft's position. The principles involved are similar to horizontal base position finding in that directions to the target are measured at points along the aircraft's course. Any two points on the course serve as the ends of a base line to determine the location of the target.

(2) *Location of plane.*—Dead reckoning is used. The aircraft flies over the battery at a constant altitude and speed, following a straight course in the general direction of the target. At the instant the aircraft passes the battery a stop watch is started and, as far as visibility will permit, the aircraft is tracked in angular height and azimuth. The aerial observer reports his altitude which is used with the angular height to determine horizontal distance and thence the ground speed of the aircraft. On the plotting board the gun arm is laid, and a line is drawn at the azimuth of the aircraft's course as determined by the tracking instrument. At any instant the position of the aircraft along this line may be located by multiplying the aircraft's ground speed by the elapsed time since passing the battery.

(3) *Location of target.*—When the aerial observer sights the target, the magnetic azimuth of his line of sight is measured and at the same instant a radio signal is sent to the battery. This magnetic azimuth together with the estimated course and speed of the target is reported by radio. The magnetic azimuth to the target is determined from one or two

additional points along the aircraft's course. The initial location of the target on the plotting board is at the intersection of the rays drawn with the reported magnetic azimuths from the plotted locations of the aircraft after a correction is applied to allow for the travel of the target between the times of observation.

■ 146. CONDUCT OF FIRE.—*a. General.*—Most of the operations in the determination of firing data and the adjustment of fire are performed directly on the plotting board. For this reason the various operations cannot be carried on concurrently to supply firing data at regular and comparatively short intervals as in standard systems. Instead, the operations are performed consecutively and furnish intermittent firing data. In the discussion that follows, fire is conducted by single piece. The spot of each impact is received, and a correction when required is applied to the firing data for the next round. It is possible to expedite firing by determining the firing data for a series of two or three consecutive shots or salvos and using the information obtained from the spots of the series in the same manner as is explained below for single rounds.

b. Initial point.—Firing data are determined from the following four elements of data: the location of the target on the plotting board, the time at which the location was made, the course of the target, and the speed of the target. The range and azimuth to the initial location of the target on the plotting board are read from the gun arm. This range and azimuth are corrected ballistically according to standard methods and the new data replotted on the plotting board. The resulting point is called the "initial point." The firing data for this point are, according to the best available information, the firing data necessary to hit the target at the time it was located.

c. Plotted points.—In predicting for a plotted point it is assumed that the firing data will change at the same rate as the target is changing its range and azimuth with respect to the directing point. For simplicity in making the first prediction, travel of the target during the time of flight is disregarded. A line is drawn from the initial point in the same direction as that in which the target is reported to be moving. A point is plotted along this line, using the estimated speed

of the target and the time that will have elapsed between the time of initial location and the time selected to fire. The range and azimuth to this point, as read from the gun arm, are the data for the pointing of the gun for the instant at which it is to be fired. These data are transmitted to the gun in time to permit setting and firing at the proper time.

d. Spotting impact.—The aerial observer reports the location of the impact with respect to the target as it would appear on the face of a clock laid over the field of fire with the center on the target and the 12 o'clock line pointing in the direction of movement of the target. (See par. 135*b* (1).) The deviation is reported by polar coordinates to the nearest whole hour and 100 yards' distance. Deviations between 50 and 100 yards from the target are reported to the nearest 50 yards. Deviations less than 50 yards are reported as "Target." On the plotting board the impact is plotted as a correction. The face of the clock used to plot the correction must therefore have its center on the point representing the plotted point, the firing data for which was used for that shot, and its 6 o'clock line must point in the direction in which the target is moving. The resulting point on the plotting board is called a "ballistic point." Neglecting errors in spotting, the range and azimuth to this point are the firing data that would have caused that shot to be a hit. A mean straight line drawn through a series of ballistic points is called a "ballistic course." The ballistic point and the ballistic course are the basis of fire adjustment.

■ 147. ADJUSTMENT OF FIRE.—*a. Rules.*—(1) During ranging fire, move the course to make full range corrections on each ballistic point, keeping it parallel to the direction of the line first drawn from the initial point. Do not change the direction of the course during ranging fire. After ranging fire, draw the course through the center of impact of all ballistic points.

(2) Enter fire for effect with a ballistic course corrected for direction and speed in accordance with the first four ballistic points.

(3) During fire for effect, make changes in the direction of the ballistic course when necessary, based on not less than the last four ballistic points.

(4) Throughout the firing, make lateral adjustment by travel predictions based on the mean travel indicated by not more than the last four ballistic points.

b. *Ranging fire.*—The first four spotted rounds are considered to be ranging shots to establish a ballistic course. Figure 67 shows a typical course as it was developed on a plotting board by the aerial fire control system. The initial point is at A. The first plotted point is located in the direction of the reported travel of the target at P_1 . B_1 is the first ballistic point. A line parallel to AP_1 is drawn through B_1 and, based on the reported speed of the target, P_2 is located. The second ballistic point is plotted at B_2 . A line parallel to the reported course of the target is drawn through B_2 which

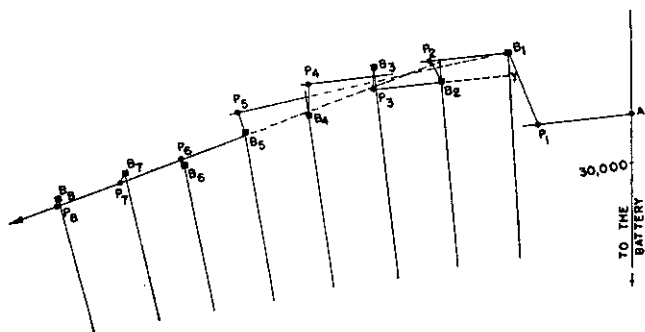

FIGURE 67.—Typical course using aerial fire control.

is the same as making full correction based on the second impact. Travel based on the distance between the two rays drawn through B_1 and B_2 is a better indication of the speed of the target than the original estimation by the aerial observer. P_3 is then located by drawing a line parallel to previous prediction lines, but the distance $B_2 P_3$ is based on the distance $B_2 Y$, taking into consideration any time difference involved. B_3 is now plotted. It indicates that a short was obtained. At this point a down correction from P_2 to P_3 has caused the fall of shots to change from over to short of the target. The target has therefore been crossed. No change in direction of course is warranted at this time. P_1

is located by using the same direction as before, but the line of prediction is drawn based on the center of impact of the three previous ballistic points. The distance to P_4 is determined by measuring the mean travel of the target between the rays. B_4 completes the series of four ballistic points and a change of direction is indicated. The ballistic course is drawn based on the ballistic points of the ranging shots.

c. Fire for effect.—This follows the ranging shots without interruption. Figure 67 shows that the four ranging shots have added much to the information concerning the movement of the target. During the fire for effect phase the ballistic course is altered from time to time so that it is the mean of at least the last four ballistic points. Travel of the target is determined by the intersection of the ballistic course with the rays drawn to the directing point.

d. Facts determined by experience.—(1) On a crossing course (that is, one which is approximately perpendicular to the battery target line), the estimate of the speed of the target can be adjusted with a few shots.

(2) On a course coincident with or approximately parallel to the battery target line, the estimate of the direction of the course can be adjusted with a few shots.

(3) In general, information that justifies a large range correction after several shots have been fired will also justify a change in the direction of the line of prediction.

(4) When the target changes the direction of its course, adjustment must begin anew.

■ 148. TRAINING METHOD.—The range section of a battery may be trained in the conduct and adjustment of fire by the use of a hypothetical course. This course is located on the plotting board so that it is some even number of degrees (such as 100 or 90) from the course to be developed by the plotter. The hypothetical course is constructed by locating on a straight line a number of target positions separated by distances equal to the travel during a firing interval. The effect of gun dispersion is included by displacing the target locations along the gun-target lines. The firing data determined by the plotter for any shot is plotted on the hypothetical course after the arbitrary degree difference has been added to or sub-

tracted from the azimuth. The point plotted in this manner is considered as an impact on the hypothetical course. It is spotted by the clock system with respect to the displaced target position for the corresponding time interval. The plotter can obtain much valuable experience in handling courses at various angles of approach by this method.

CHAPTER 16

EMERGENCY ONE-STATION FIRE CONTROL SYSTEM

■ 149. GENERAL.—The emergency one-station fire control system permits the delivery of effective fire on a moving target when the range finding element of the battery is inoperative. It is designed for use by rapid fire batteries of two or more guns. One observation station located near the firing battery is required for this system. This station serves as an observation post from which the range and course of the target are estimated, present azimuths are measured, and lateral deviations and range sensings are obtained. In the explanation that follows it is assumed that the range finding element is the only part of the battery that is not functioning. Future position data (that is, data for the set-forward point) are determined on the plotting board. Ballistic corrections are applied to these data by means of the standard correction devices, and the firing data are sent to the guns for use in either case II or case III pointing.

■ 150. PROCEDURE.—*a. General.*—The direction of the course is approximated by pointing the telescope of the observation instrument in the direction the target is moving so that the telescope and the course are as nearly parallel as possible, and then reading the azimuth circle. The range to the target is estimated. The present azimuth of the target is read on the sounding of the time interval signal and is transmitted to the plotting board. The arm setter sets at this azimuth an arm which is pivoted at the center of the board. The estimated course of the target is drawn on the plotting board using the approximated direction and the estimated range. An arbitrary course, which will be referred to as the "false course," is drawn parallel to the estimated course near the circumference of the plotting board. Using the present azimuth of the target and the time of flight for ranges being sent to the guns, predicted azimuths are determined on the false course employing the normal method of prediction. The false course is altered from time to time to keep it ap-

proximately parallel to the course being developed on the plotting board. Fire adjustment in range is based on the sensings of impacts and is made by assuming courses which are changed in range, in direction, or in both. Fire is divided into two phases designated as ranging fire and fire for effect.

b. Definitions.—In order to clarify the discussion that follows, it is desirable that definitions of the following terms which appear in the glossary, appendix I, be reviewed: Searching up (down), ballistic area, ballistic point, ballistic course, ranging fire, fire for effect.

■ 151. RULES FOR ADJUSTMENT OF FIRE.—Rules for fire adjustment applicable to standard systems of fire control are contained in FM 4-10. The following rules are applicable to this system only:

a. Enter fire for effect by assuming a course parallel to the estimated course and passing through either the ballistic point or the middle of the 500-yard ballistic area established by ranging fire.

b. Continue firing on an assumed course until the fall of shots indicates that it is not correct.

c. If at any time the fall of shots indicates that the course being fired on is not correct, begin searching in the proper direction.

d. An incorrect course is indicated when—

(1) All shots of the *first salvo* fall in the same sense; or

(2) After a ballistic point is established on a ballistic course, *two consecutive salvos* fall in the same sense.

e. When a ballistic area or point is located while searching, re-lay and resume firing on a new ballistic course through that area or point.

f. Adjust laterally by the standard method for the battery. It is important that impacts fall on or very close to the battery target line at all times so that they can be sensed for range.

■ 152. SPECIAL CASE.—When the target assumes a course within 15° of being directly toward or directly away from the observation station, a special problem is encountered in which the false course on the plotting board will not satisfactorily serve its purpose. In this special case, cross section

paper is used as a time range chart in lieu of the plotting board, and the method explained herein is employed to develop a graph to furnish firing ranges in the same manner as the ballistic course is developed on the plotting board. When the target assumes such a direction, it is necessary for the range section to know whether the target is coming in or going out and its approximate speed so that the initial graph can be drawn with a slope that is approximately correct or is at least sloping in the proper direction.

■ 153. ILLUSTRATIVE EXAMPLE.—*a. Situation.*—A battery of four 155-mm guns has been assumed with a firing interval of 20 seconds, data being sent to the guns 20 seconds before firing, with a time of flight of 25 seconds. Therefore, while searching, one salvo is wasted after a ballistic area or a ballistic point is established, and one salvo may be saved by ordering a re-lay. In order that information relative to the fall of the shots may be marked quickly on the plotting board, symbols listed in figure 68 are used.

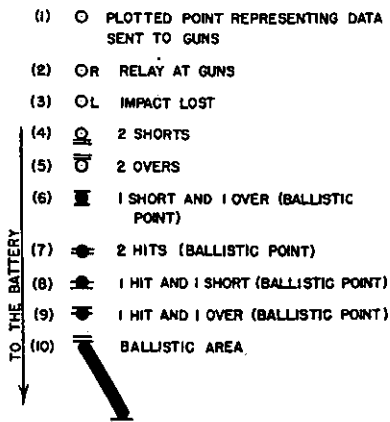

NOTE: SYMBOLS (6), (7), (8), (9), AND (10)
ESTABLISH THE BALLISTIC COURSE

FIGURE 68.—Symbols for plotting board, emergency one-station fire control system

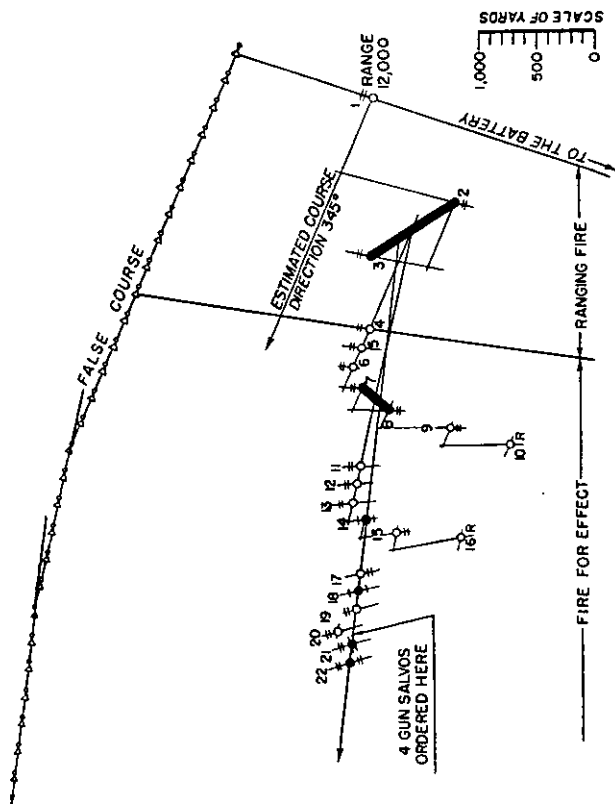

FIGURE 69.—Typical course, using emergency one-station fire control.

b. Explanation.—Figure 69 shows a typical course as developed on the plotting board by using emergency one-station fire control. Ranging fire has established a 500-yard ballistic area between points 2 and 3. A course parallel to the estimated course is drawn through the center of the ballistic area. Fire for effect is begun by sending the data for point 4 to the guns. Due to the timing of the system and the time of flight, the spots of shots fired on data for point 4 are not received until after the shots are fired with data for point 5 and data

for point 6 are sent to the guns. When shots fired on data for 4 are reported as "over-over," searching down is begun by decreasing the range 150 yards to point 7. Shots fired with data for point 5 are reported as "over-over," and the range is decreased 300 yards to point 8. Shots fired on data for 6 are sensed as "over-over," and the range is decreased 600 yards to point 9. Shots fired with data for point 7 are reported as "over-over," and again the range is decreased 600 yards to point 10. The shots fired with data for point 8 are sensed as "short-short." A ballistic area is located between points 7 and 8 so "Re-lay" is ordered on data for 10. A course is drawn through the midpoints of the two ballistic areas and data for 11 are sent to the guns. The spots of shots fired on data for point 11 are not received until after data for 13 are sent to the guns. When spots for 11 are reported as "over-over," searching down is begun on data for 14. Since a ballistic point is located at point 14, a ballistic course is drawn through the ballistic point and the two ballistic areas shown on the plotting board. After data for 19 are sent to the guns, shots fired on data for point 17 are spotted as "short-short." Therefore searching up is begun with data for 20. However, when the spot of the salvo fired on data for 18 produces a ballistic point, point 21 is brought back to the ballistic course. Since the ballistic course now contains four ballistic areas or points, battery salvos are ordered and the first battery salvo is fired on data for 21. When the spot of the salvo fired on data for 19 is reported as "over-over," searching is not begun, because after a ballistic point is located on a ballistic course two consecutive salvos must fall in the same sense before searching takes place. Firing should continue on the present ballistic course until two consecutive salvos fall in the same sense, in which case two-gun salvos should be ordered and searching in the proper direction should begin.

■ 154. TRAINING.—a. Training in plotting board procedure can be obtained with the aid of a hypothetical course. Such a course is constructed as follows:

(1) Assume a path of the target on the plotting board and draw rays every half degree to intersect it.

(2) With the dispersion tape and scale (see FM 4-10) plot each impact of a two-gun salvo on each ray.

(3) Connect the plotted impacts of shots from each gun, forming two zig-zag lines, making each line of a width to represent the actual danger space (see FM 4-10) for the target.

b. The hypothetical course is placed on the plotting board on one side of the center line of the field of fire while the ballistic course is developed on the other side. There should be a difference of some even number of degrees between the two courses, such as one quadrant on the 110° plotting board or 100° on the Cloke board. When a range and an azimuth are obtained from the ballistic course, the constant angular difference is applied to the azimuth and the point is plotted on the hypothetical course. If the point plots short of the zig-zag lines, the spot is "short-short"; if over, it is reported as "over-over." If it falls between the two lines the salvo consists of one over and one short. If the point at any time falls upon a line a hit is reported. Lateral movement of the target can be simulated by assuming a constant angular speed such as $\frac{1}{2}^\circ$ for each observing interval. By using the principles of the emergency one-station fire control system, the hypothetical course is developed as a ballistic course on the plotting board in the same manner as the ballistic course of an actual target would be developed.

CHAPTER 17

POINTING METHODS AND INSTRUMENTS

	Paragraphs
SECTION I. General.....	155-158
II. Pointing in elevation.....	159-168
III. Pointing in direction.....	169-176
IV. Examples of pointing adjustments.....	177-180

SECTION I

GENERAL

■ 155. DEFINITION OF POINTING.—The operations of the range section culminate in the determination of the range (or elevation) and the deflection (or azimuth) at which the pointing instruments on a cannon must be set for firing at a particular instant. The data so determined pertain to the setting of the axis of the bore of the cannon in elevation and in direction, that is, setting it at the proper vertical angle and at the proper horizontal angle. This setting operation is called "pointing."

■ 156. METHODS OF POINTING IN ELEVATION.—There are two methods of pointing in elevation used by seacoast artillery. The commoner method is the one discussed and illustrated in paragraph 21, in which the axis of the bore is given a definite elevation above the horizontal. The setting is called the "quadrant elevation." Except for batteries equipped with electrical data transmission systems (par. 186), the pointing equipment used is either a range disk or an elevation quadrant. The second method is used only on the 3-inch rapid fire guns. In this method the sight is waterlined on the target, and the gun is elevated above that line by the angular amount necessary to cause the projectile to fall at the proper range. This angle is called the "angle of elevation." It is set off by raising the rear end of the sight according to a scale graduated in angles but marked in terms of the range.

■ 157. METHODS OF POINTING IN DIRECTION.—There are also two general methods of pointing in direction. In one method the target is used as an aiming point, and the axis of the bore is caused to diverge from the line of sight by an angular amount called the “deflection.” The cannon is pointed by some kind of telescope or telescopic sight. In the other method, the axis of the bore is pointed in azimuth. There are two methods of pointing the bore in azimuth—by a sight and a fixed aiming point other than the target, and by an azimuth circle or an azimuth indicator. (See par. 186.) Both methods of pointing in direction are discussed and illustrated in paragraph 21.

■ 158. CASES OF POINTING.—There are three cases of pointing, which are defined according to the combination of pointing methods used. The definitions are as follows:

a. *Case I.*—Pointing in which both direction and elevation are given the piece by means of a sight pointed at the target.

b. *Case II.*—Pointing in which direction is given the piece by means of a sight pointed at the target, and elevation by means of an elevation quadrant or a range disk.

c. *Case III.*—Pointing in which direction is given the piece by means of an azimuth circle, of a “match the pointer” indicator (par. 186), or of a sight pointed at an aiming point other than the target, and elevation by means of an elevation quadrant, of a range disk, or of a “match the pointer” indicator.

SECTION II

POINTING IN ELEVATION

■ 159. REQUIREMENTS.—In order that the axis of the bore of a cannon may be pointed correctly in elevation, the pointing equipment must indicate the true vertical angle at which the axis of the bore is elevated above the reference line that is being used. This condition requires not only that the mechanism indicate correct angles but also that the angles indicated be vertical angles. The first requirement may be satisfied by providing the pointing equipment with a longitudinal level or by adjusting the mechanism with the aid of a clinometer and a clinometer rest. Elevation quadrants should indi-

cate the quadrant angle of elevation at which the axis of the bore is raised; range disks should indicate the range, corrected for height of site, that corresponds to the quadrant elevation at which the axis of the bore is raised; range scales on sights for 3-inch rapid-fire guns should indicate the range corresponding to the angle of elevation of the axis of the bore above the line of sight. The second requirement may be satisfied by insuring that the trunnions of the cannon are level or by equipping the mount of the pointing mechanism with means for measuring vertical angles. (See TM 4-210.) This device will be referred to as a cross level in the discussion which follows.

NOTE.—All new elevation equipment will employ the mil unit, but existing elevation apparatus using degrees and hundredths will be retained in service. Use of the mil unit will facilitate use of electric data transmission systems for seacoast artillery. (See par. 186.)

■ 160. **LEVEL OF TRUNNIONS.**—If the axis of the trunnions of a cannon is not level, the axis of the bore will depart from the vertical plane as the cannon is elevated. This will affect the pointing in both direction and elevation. If it were necessary to level the trunnions of mobile mounts precisely every time they were emplaced, their mobility would be greatly impaired. Therefore the sight mounts of mobile artillery are furnished with cross levels. Fixed guns are permanently emplaced and, if the base rings are maintained level, do not need such a device. The level of the base ring is checked periodically and the errors in level recorded. The effect of small errors in the level of the base ring on pointing in direction is disregarded, and correction for the effect on the range is accomplished with the aid of a clinometer and a clinometer rest as explained in other paragraphs of this section.

■ 161. **CLINOMETER AND CLINOMETER REST.**—The clinometer is an instrument designed for the precise measurement of vertical angles. It is equipped with a cross level. The clinometer rest consists of a plug which fits tightly into the muzzle of the cannon, leaving a projecting axis that coincides with the axis of the bore. The clinometer is mounted on the projecting axis. Before a clinometer is used it should be checked for adjustment. Set the clinometer at zero and place it and the clinometer rest in position on the cannon. Center the cross

level bubble and elevate or depress the cannon until the bubble of the longitudinal level is centered. *Check and re-center both bubbles.* Reverse the clinometer on its rest and recenter the cross level bubble; if the longitudinal bubble does not remain centered, the instrument is out of adjustment. If no other clinometer is available, the amount of the error should be determined and proper corrections should be applied to all readings and settings. When the clinometer is used it should always be protected from the wind and sheltered from the direct rays of the sun.

■ 162. CHECK OF LEVEL OF BASE RING ON FIXED CANNON.—

a. Check of level.—The level of the base ring should always be checked prior to firing, when the pointing equipment of the cannon is not equipped with longitudinal and cross levels. This is the usual case with all fixed seacoast artillery. The check may be made as follows:

(1) Set the clinometer at any convenient elevation and place it and the clinometer rest in position on the cannon.

(2) Traverse the cannon to one edge of the field of fire, center the cross level bubble, and change the clinometer setting until the longitudinal bubble is centered. Check and recenter both bubbles. Read and record the clinometer setting and the azimuth.

(3) Without changing the elevation of the cannon, traverse it 10° (or 15°) toward the center of the field of fire, cross level, and center the longitudinal bubble by changing the setting of the clinometer. Read and record the clinometer setting and the azimuth.

(4) Repeat the procedure for each 10° or 15° throughout the field of fire.

(5) Examine the record and select an azimuth at which to adjust the range disk for zero correction. The selected azimuth should be such that the corrections to be applied at other azimuths will be a minimum. Compute the corrections in angular units for the other azimuths. (See par. 177, example *a.*)

b. Application of corrections.—The angular corrections computed must be converted into corrections in yards for ready application to the firing data. A perusal of the firing tables will disclose that the exact correction in yards for a

given angular correction varies with the quadrant elevation. Therefore a decision must be made as to the particular range corrections to be applied. This will depend on the conditions involved, such as size of angular correction, variations in size of range correction, and the limiting ranges of the armament. Usually a mean of the corrections applicable at the limiting ranges will be sufficiently accurate. The corrections may be combined with those for gun difference and the resultant correction displayed on the loading platform. (See par. 37.)

■ 163. RANGE DISKS.—*a. Description.*—(1) Range disks will be found on all fixed seacoast artillery except 12-inch mortars. They furnish means of pointing a cannon in elevation by the use of ranges, thus eliminating the necessity for converting them into quadrant elevations. The device consists of a disk connected mechanically to the elevating mechanism by gears and shafts so that it turns as the quadrant elevation of the cannon is varied. The range setting is indicated opposite a fixed index on the mount. Means are usually provided for making small adjustments of the mechanism by moving either the range disk or the index. Range disks are equipped with neither longitudinal nor cross levels and include no other means for insuring the setting of vertical angles.

(2) Range disks are graduated not only for the particular combination of cannon, powder charge, and projectile but also for the particular location of the cannon, that is, its particular height above the target at mean low water. The data for the graduation is compiled in elevation tables which are the range elevation relation of the combination corrected for the height of site. The range disk is mounted on the cannon and the cannon pointed at known angles of quadrant elevation. The corresponding ranges are then marked on the range disk opposite the index.

b. Adjustment.—(1) Traverse the cannon to the azimuth selected for the range adjustment when checking the level of the base ring. (See par. 162.)

(2) Select an elevation near the minimum limit of the cannon, set the clinometer at that elevation, and place it in position on the clinometer rest. Cross level the clinometer and elevate or depress the cannon until the longitudinal bubble is centered. Check and recenter both bubbles. In

order to eliminate the effect of backlash, the last motion of the cannon should be made in the same direction (that is, either in elevation or in depression) throughout the operation.

(3) Note the discrepancy between the indicated range and the range as given in the elevation tables.

(4) Repeat the procedure for an elevation at midrange and one near the maximum limit of the cannon.

(5) Examine the results of the check and determine the amount of the desired range correction. An analysis of the discussion (see also par. 162) indicates that there may be two common causes of error in the adjustment of the range disk: first, an error in the level of the base ring; and, second, an error due to slippage somewhere in the mechanical system between the bore and the range disk. Both of these causes would have a similar effect on the range error. A varying discrepancy, as the quadrant elevation is varied, may be expected between the range as indicated on the range disk and the range as given in the elevation tables. Moreover, the size of the range error may be expected to decrease as the quadrant elevation is increased. (See part 2, table A, of any firing tables.) If the results of the check agree with these conclusions, the error may be corrected for by displacing the range disk, and the resultant correction should be good throughout the limits of elevation. The adjustment may be made at any elevation by making the proper range correction for that elevation. It should be noted that in moving the range disk a flat, angular correction is made. For example, Firing Tables 12-F-3 show that a change of 1 minute in elevation changes the range by 24.4 yards at 6,000 yards and by 9.2 yards at 25,000 yards. Therefore, an adjustment made in yards at any elevation holds good in angular units at any other elevation. If the error found is irregular and the cause cannot be determined, the correction should be chosen to meet the particular situation. (See par. 177, example *b*.)

c. Operation.—The range setter elevates or depresses the cannon until the firing range as received from the plotting room is indicated on the range disk. If corrections for displacement and base ring level are to be made at the emplacement, he sets the firing range corrected by the amount of those corrections.

■ 164. ELEVATION QUADRANT, M1908 (fig. 70).—*a. Description.*—The elevation quadrant, M1908, is for use on the 12-inch fixed mortar. The quadrant bracket is attached by two screws to the left trunnion of the mortar. The elevating arc consists of a series of teeth on the bracket, each representing 1° of arc. The arm sector is toothed to fit the elevating arc and bears an index which registers with the elevating scale on the arc. It is pivoted at its other end to the bracket. The arm sector is set to the degrees of elevation by shortening its length against the action of a spring, moving

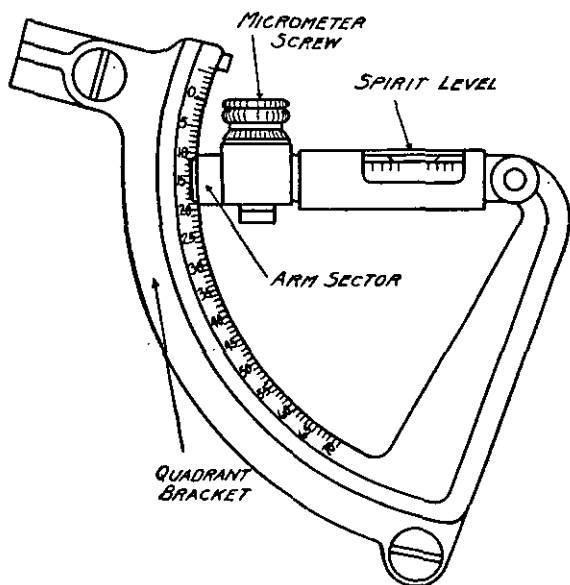

FIGURE 70.—Elevation quadrant, M1908 (for fixed mortars.)

its toothed end to the proper position on the arc and releasing it. This arrangement admits of settings from 0° to 70° . Minutes of elevation are set by rotating the micrometer screw on the arm sector. A level on the arm sector indicates when that member is level. This quadrant is not equipped with a cross level.

b. Adjustment.—The adjustment of the elevation quadrant, M1908, may be made with the mortar pointed in direction at any azimuth. The procedure is as follows:

(1) Elevate the axis of the bore to quadrant elevations of 45°, 55°, and 65° by means of a clinometer and check the readings of the quadrant.

(2) Examine the results of the check and determine the desired correction. Any error indicated should be a constant error at all elevations. If it is not, the elevation quadrant should be turned in to the ordnance officer for repair. Sometimes the quadrant may be placed in adjustment by improvised methods, such as shimming. If not, the correction may be applied to the quadrant elevation by the elevation setter or in the plotting room.

c. Operation.—The elevation setter sets the quadrant to the firing elevation as received from the plotting room. He elevates the mortar until the level bubble is centered.

NOTE.—Some mortars in service are equipped with elevation quadrant, M1906, which is similar in principle to the M1908 quadrant but has the teeth of the arc cut in degrees from 45° to 75°.

■ 165. ELEVATION QUADRANT, M1917 (fig. 71).—*a. Description.*—The elevation quadrant, M1917, is for use with railway artillery and with guns mounted on modern barbette carriages. It is equipped with a cross level. The quadrant is attached by a fulcrum to a rocker. A tapered shank on the rocker fits in a groove in a support on the right trunnion of the cannon. The purpose of this arrangement is to permit movement of the quadrant about a longitudinal axis parallel to the bore for cross leveling. The elevating arc bears on its outer edge a worm rack that engages a worm fastened to the quadrant arm. The arm is set in elevation by rotating the worm by means of the micrometer screw at its lower end. For fast motion the worm may be disengaged by lifting the throwout lever. Degrees of elevation are indicated on the elevation disk which is geared to the inner edge of the elevating arc through a shaft and two friction disks. Minutes of elevation are indicated on the micrometer screw. The cross level and longitudinal level are carried on the quadrant arm. The cross level bubble is centered by means of the cross level screw. An angle of site mechanism is included at the front

of the quadrant arm, by which the longitudinal level may be displaced through small angles from its normal position.

b. Adjustment.—(1) Point the cannon in direction at any azimuth. Elevate the axis of the bore, by means of a clinometer, to quadrant elevations corresponding to short, medium, and long range, and check the readings of the quadrant.

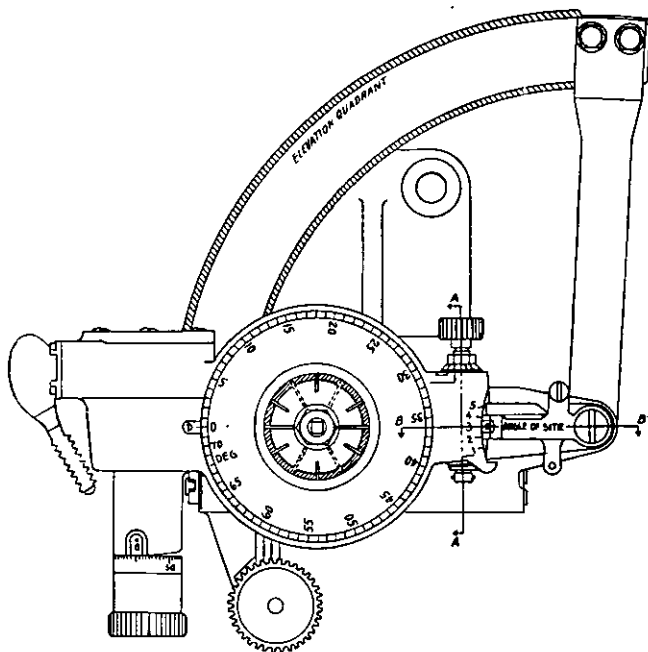

FIGURE 71.—Elevation quadrant, M1917.

(2) Examine the results of the check and determine the desired correction. If the error is not constant, the quadrant should be turned in to the ordnance officer for repair. The correction may be applied by unscrewing the locking nuts on the elevation disk and micrometer and setting the disk and micrometer to the desired reading or by use of the angle of site mechanism. (See example, par. 178.)

c. *Operation.*—The elevation setter sets the quadrant to the firing elevation as received from the plotting room. He elevates the cannon until the longitudinal bubble is centered, cross levels the quadrant, and recenters the longitudinal bubble.

■ 166. QUADRANT SIGHT, M1918A1 (fig. 72).—a. *Description.*—

(1) The quadrant sight, M1918A1, is an instrument for pointing a cannon in both elevation and direction. It is used on the 155-mm gun. The quadrant sight is permanently mounted on the left trunnion of the gun in a support which permits movement about a longitudinal axis parallel to the bore of the gun for cross leveling. The cross level screw is under this support.

(2) The principal parts of the elevation indicating mechanism are the worm, worm wheel and pinion, elevation scale, sight shank, and the levels. Elevations are set by turning the elevating worm by means of the elevating screw (or micrometer) at its rear end. This rotates the worm wheel about its axis. The angle through which the worm wheel is rotated is indicated on the elevation scale which is engraved on a drum screwed to the worm wheel.

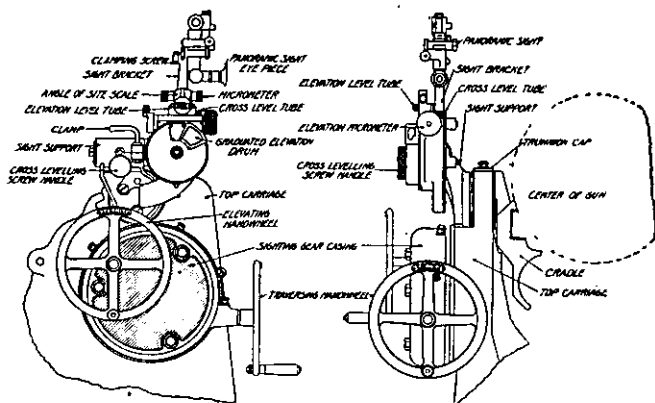

FIGURE 72.—Quadrant sight, M1918A1.

(3) The sight shank (or bracket) is of irregular shape. Its lower end is an arc which passes through the body of the sight and around the pinion on the worm wheel. A rack on its inner surface meshes with that pinion. Attached to the upper end of the arc is a straight piece which extends vertically upward and out of the body of the sight. The lower end of this vertical part carries the levels. The cross level is fixed to the sight shank. The longitudinal level is attached to the shank through the angle of site mechanism, by which it may be displaced through small angles from its normal position perpendicular to the sight shank.

(4) The angular displacement of the elevating worm wheel is transmitted through the pinion and rack to the sight shank whose vertical part is displaced by a proportionate amount from the vertical. If the gun is then elevated until the longitudinal bubble is centered and the sight cross leveled, the sight shank will be brought back to the vertical and the axis of the bore pointed to the quadrant elevation that was set on the elevation scale. Elevations are indicated in mils.

(5) The upper end of the sight shank forms a seat for a panoramic telescope by which the gun may be pointed in direction.

b. Adjustment.—(1) Point the gun in direction at any azimuth.

(2) Point the bore in elevation, by means of a gunner's quadrant, to quadrant elevations corresponding to short, medium, and long ranges, and check the readings of the elevation scale.

(3) Examine the results and determine the desired correction. If the error is not constant the sight should be turned in to the ordnance officer for repair. The correction may be applied by displacing the elevation pointer or by use of the angle of site mechanism.

c. Operation.—The elevation setter sets the quadrant elevation as received from the plotting room. He elevates the gun until the longitudinal bubble is centered, cross levels the sight, and recenters the longitudinal bubble.

■ 167. GUNNER'S QUADRANT.—*a. General.*—One gunner's quadrant per cannon having quadrant seats is issued to coast artillery batteries for use in checking the adjustment of

elevation equipment attached to guns and carriages. It may be used *in emergency* for pointing the cannon in elevation. It is not provided with a cross level. Consequently, the axis of the trunnions of the cradle must be level in order to read true vertical angles by means of this instrument. There are two types in use, one having degree graduations and the other having mil graduations. Of the degree type there are two models, M1898 and M1897; of the mil type the models are M1 and M1918.

b. *Gunner's quadrant M1* (fig. 73).—This type consists of a frame and a quadrant arm (or arm sector). One portion of the frame forms an elevating arc on each scale of which

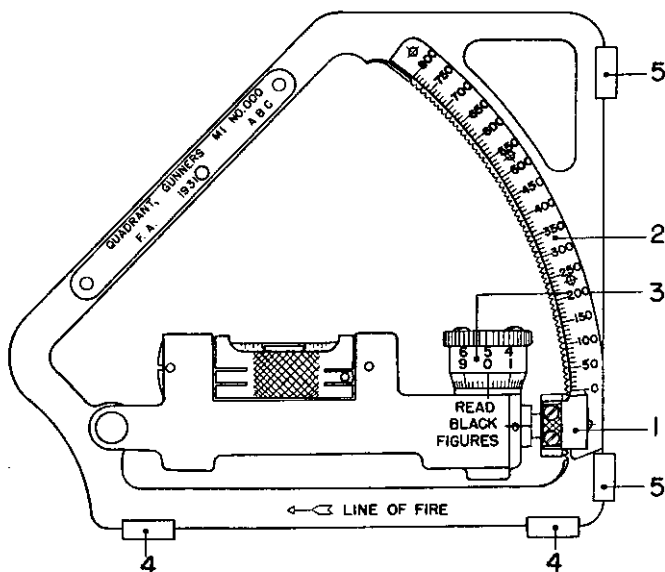

FIGURE 73.—Gunner's quadrant M1.

is an elevation scale (2), one for elevations from 0 to 800 mils and the other for elevations from 800 to 1,600 mils. The inside edge of the arc has teeth at 10-mil intervals. The quadrant arm carries a spirit level and is pivoted at

one end to the frame. The other end has a toothed sector with a ratchet device (1) which permits a rapid setting on the elevation scale at 10-mil divisions by engaging the arc at the proper elevation. Closer settings (to 0.2 mils) are made by means of the micrometer drum (3). The quadrant has two sets of leveling feet, one set (4) for use when setting elevations from 0 to 800 mils and the other set (5) for use in setting elevations above 800 mils.

c. *Older models* (mentioned previously).—These models, both mil type and degree type, differ from the M1 in that they have no ratchet device and no micrometer drum. The toothed sector at the end of the arm is engaged on the arc by shortening its length against a spring, moving it to the proper elevation and releasing it. The level is carried in a slide on the arm. The arm is slightly curved, and the closer settings are made by moving the slide and bubble along the arm to the proper graduation. (See fig. 74.)

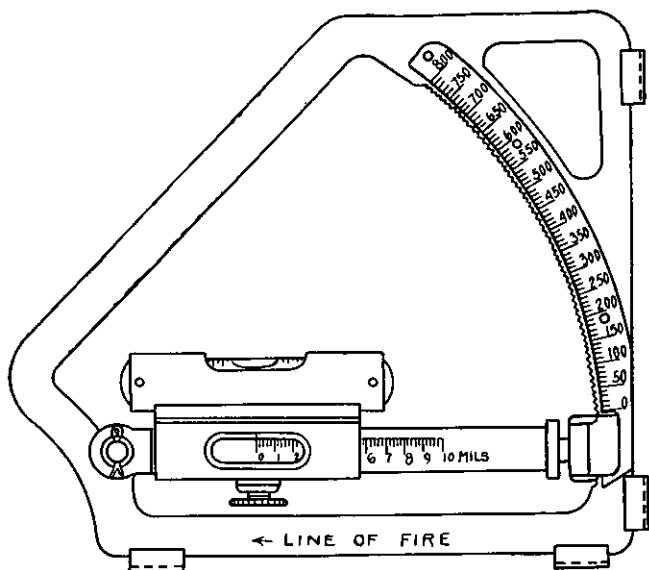

FIGURE 74.—Gunner's quadrant, M1918.

d. Adjustment.—The quadrant may be checked for adjustment by comparison with an adjusted quadrant or a clinometer or it may be checked independently (see par. 161). If found to be out of adjustment another quadrant should be procured.

e. Operation.—Set the elevation on the quadrant, place the leveling feet squarely on the machined quadrant seat on the breech of the gun, and elevate the gun until the bubble is centered.

■ 168. ELEVATION SCALES.—Some types of barbette mounts have elevation scales graduated on the surface of the elevating arc or on a strip of metal attached to the arc. These scales are graduated in degrees and minutes, with a least reading of 10 minutes, and are read opposite a fixed pointer on the mount. The scales cannot be read accurately enough for pointing the cannon, except in emergency, but may be used to check the approximate elevation. The method of checking the adjustment of elevation scales is similar to that described for quadrants.

SECTION III

POINTING IN DIRECTION

■ 169. LEVEL OF TRUNNIONS.—Except for one requirement, the conditions essential to correct lateral pointing depend on the method of pointing used. The excepted requirement is that the pointing equipment indicate horizontal angles. This is necessary regardless of the instruments and methods used. This procedure is assured by the same methods as are used for pointing in elevation, namely, leveling the base ring on fixed mounts and providing a cross level on mobile mounts. The effect on the lateral pointing of small errors in the level of the base ring of fixed mounts is ignored.

■ 170. CASE I AND CASE II ADJUSTMENT.—In case I and in case II pointing, cannon are pointed in direction by means of a telescope (pars. 172 and 173) and a deflection setting. In order that the axis of the bore may be set at the required horizontal angle with the line of sight, the proper relation must first be established between the axis of the bore and

the normal position of the line of sight, that is, its position when the deflection setting is normal. Since the telescope is not mounted in the same vertical plane with the axis of the bore, the normal line of sight and the axis of the bore cannot be made to coincide, but they can be made parallel or they can be made to intersect at any desired distance from the cannon. The process by which the axis of the bore and the normal line of sight are made parallel or are made to converge on a point is called "boresighting." Once this relationship has been established, the setting of any deflection other than normal will cause the line of sight to be moved from its normal position through an angle equal to the difference between the actual deflection set and the normal setting. If the cannon is then traversed until the line of sight of the telescope is directed at the target, the cannon will be pointed in the desired direction.

■ 171. CASE III ADJUSTMENT.—*a. Orientation.*—When using case III methods, the cannon is pointed in azimuth by the use of an azimuth circle or a panoramic telescope pointed at an aiming point other than the target. The necessary adjustment is called "orientation" and consists of directing the axis of the bore at a known azimuth and adjusting the pointing instrument or the azimuth circle to indicate that azimuth.

b. Determination of azimuth.—There are several ways in which the azimuth of the axis of the bore of a cannon may be determined. For the methods and the adjustments necessary see paragraph 176.

c. Aiming point and aiming rule.—(1) Azimuth circles are placed on the mounts concentric with the pintle center (or center of rotation) of the cannon and, if correctly adjusted at one azimuth, will indicate all azimuths correctly. A panoramic telescope is not so mounted but is displaced from the axis of rotation of the cannon by a small distance, the exact displacement depending on the type of mount. As a consequence, there is parallax between the axis of rotation of the sight and that of the cannon. If a fixed aiming point is used, this parallax introduces an error into all azimuths except that at which the orientation was made. If the aiming point can be selected so that the sight displacement is

less than $1/2000$ of the distance to the aiming point, the maximum error due to the displacement will be less than 0.03° and may be neglected.

(2) The aiming rule was devised for use when a suitable fixed aiming point could not be found. It acts as an aiming point at infinity and eliminates errors due to sight displacement. (See par. 174.)

■ 172. TELESCOPES (FORMERLY CALLED TELESCOPIC SIGHTS) USED IN POINTING—*a. Description.*—Instruments of this type (fig. 75) are provided for all fixed seacoast artillery mounts except the 12-inch mortar mount, and for the 12-inch and 14-inch railway gun mounts. They are similar in design to the telescope of an azimuth instrument. (See par. 42.) The reticle contains either cross wires or some form of clover leaf design in which the target should be centered. The telescopes are of varying size and magnifying power to fit the conditions under which they are used. The mounts are also similar in general principles but vary in minor details. The mount is in the form of a cradle which is attached to the carriage in such a manner as to permit vertical motion of the telescope if necessary. On some types of mount, deflections are set by moving the telescope horizontally; on others, the sight is held fixed and the vertical cross wire is

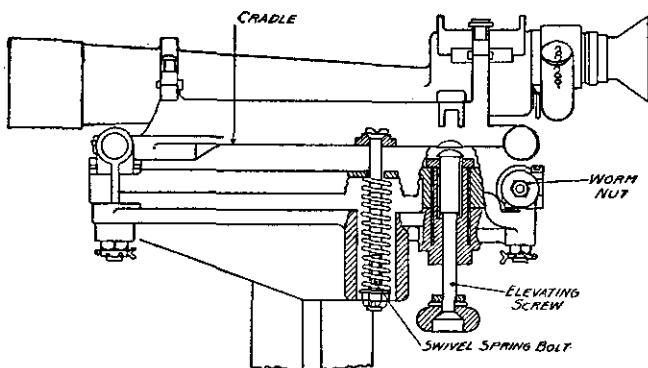

FIGURE 75.—Telescope, M1912, and mount.

moved from its normal position. Regardless of the method used, a deflection setting greater than normal moves the axis of the bore to the right and a setting less than normal moves it to the left. This is in accord with the general rule previously given, that is, "Right, Raise; Left, Lower." The deflection scale is usually on the mount. It is graduated in degrees and hundredths. The normal of the scale depends on the type of mount and may be either 3.00, 6.00, or 10.00. The telescope mounts on railway artillery include additional members to permit longitudinal leveling and cross leveling. (See TM 4-210.)

b. Adjustment.—These instruments are used only for case I and case II pointing. Therefore, the only adjustment necessary consists of boresighting. The proper adjustment for all conditions of firing is that in which the axis of the bore is made parallel to the line of sight with normal deflection setting. However, since the displacement of the telescope is never more than 1.5 yards, the error introduced by adjusting for convergence will be negligible if the range used is sufficiently great. Furthermore, cannon using these telescopes are usually so emplaced that there are suitable datum points in the field of fire on which the cannon may be boresighted. Hence, the usual adjustment is that of boresighting for convergence. The procedure is as follows:

Select a datum point at suitable range; that is, beyond the mean range of the cannon. Place a boresight (see note) in the breech of the cannon and a thread along the vertical diameter of the muzzle. Direct the cannon at the datum point by sighting along the axis of the bore. Adjust the sighting mechanism so that the deflection scale indicates normal with the telescope pointed at the datum point. On some types of instrument this may be done by directing the telescope at the datum point and adjusting the deflection scale to read normal. On others, no adjustment can be made on the scale but the telescope may be moved on its standard after loosening some setscrews. On the latter type, the adjustment is made by setting the deflection scale at normal and moving the telescope on its standard until the line of

sight passes through the datum point. (See par. 179, example *a*.)

NOTE.—A boresight is a thin piece of metal containing a peephole and cut to fit snugly across the breech recess of a cannon. When the boresight is placed in the breech of the type of cannon for which it was made, the peephole is on the axis of the bore.

c. Operation.—The gun pointer sets the deflection as received from the plotting room and tracks the target with the vertical cross wire by traversing the cannon.

d. Lateral adjustment of fire by jumping splashes.—(1) When using case I or case II pointing, the gun pointer is sometimes required to adjust the fire in direction. (See par. 116.) In this method, after the piece is fired he continues to track the target with the deflection setting unchanged. When the splash occurs he stops traversing the piece and brings the vertical cross wire on the splash by means of the deflection screw. This adds the lateral deviation algebraically to the deflection, giving a corrected deflection for use with the next shot.

(2) A similar method of conducting the lateral adjustment is that in which an observer with an azimuth instrument is stationed on or near the gun-target line. He sets the splash pointer to the deflection used on the gun and tracks the target with that pointer until the splash occurs. He then stops traversing the instrument, moves the pointer to the splash, and calls off to the gun pointer the corrected deflection.

■ 173. PANORAMIC TELESCOPES (figs. 76, 77, and 78).—*a. Description, general.*—(1) Panoramic telescopes are provided for all mobile seacoast artillery mounts for use in case II or case III pointing and for 8-inch barbette mount, M1918. They are of varying size and magnifying power but are similar in construction and in principles of operation. The telescope consists of a fixed elbow and a rotating head. An attachment on the back of the elbow fits in the telescope mount on the gun carriage. The elbow contains the eyepiece and objective and has a reticle with horizontal and vertical cross wires. Other optical elements are also included in the telescope which permit movement of the rotating head to change the direction of the line of sight without disturbing

the line of collimation. The head may also be moved through a few degrees of elevation on both sides of the horizontal.

(2) The head is attached to and supported by a movable limb which is housed in the upper part of the elbow. An azimuth scale carried on the limb shows through a window in the housing. On some models, the azimuth scale is graduated in degrees with a least reading of 1° ; on others, in mils with a least reading of 100 mils. Smaller readings are marked on the azimuth micrometer which is fastened to a handwheel geared to the movable limb. Indices fixed to the housing are

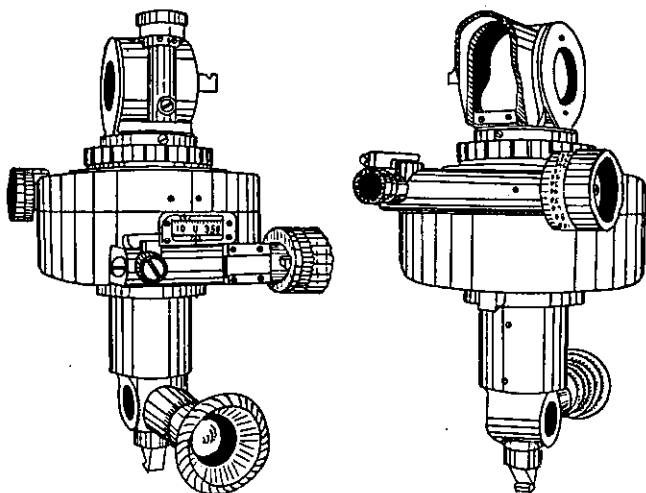

FIGURE 76.—Panoramic telescope, M1922.

provided for the azimuth scale and the micrometer. The head may be rotated by turning the azimuth handwheel or by disengaging the handwheel by means of a throwout lever and turning the head. Azimuth readings increase as the head is turned counterclockwise, that is, as the line of sight is turned to the left. (See note, *b* below.) On the movable limb, the diameter that coincides with the line of sight is indicated by a reference mark. When that reference mark is opposite the fixed azimuth index in the window of the hous-

ing, a reading of the micrometer may be noted for that telescope and mount, at which reading the line of sight is parallel to the axis of the bore.

(3) Both the azimuth scale and the micrometer are so attached to the telescope that they may be adjusted to read any desired azimuth for any position of the line of sight.

(4) All mounts for panoramic telescopes, being on mobile armament, are provided with means for longitudinal leveling and cross leveling.

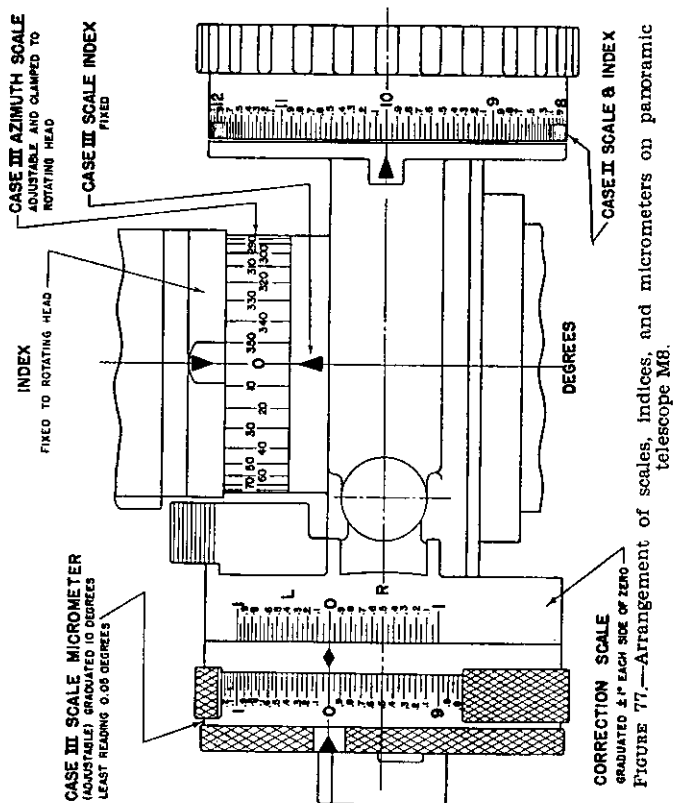

FIGURE 77.—Arrangement of scales, indices, and micrometers on panoramic telescope M8.

b. Panoramic telescope M8 (formerly T2).—(1) This telescope has been adopted as standard for 155-mm guns used by the Coast Artillery Corps and for the 8-inch gun railway mount M1. It is similar to older panoramic telescopes but is somewhat larger, has improved mechanical features, and has a six-power optical system. It is an all-purpose telescope (prior to development of this instrument, two instruments

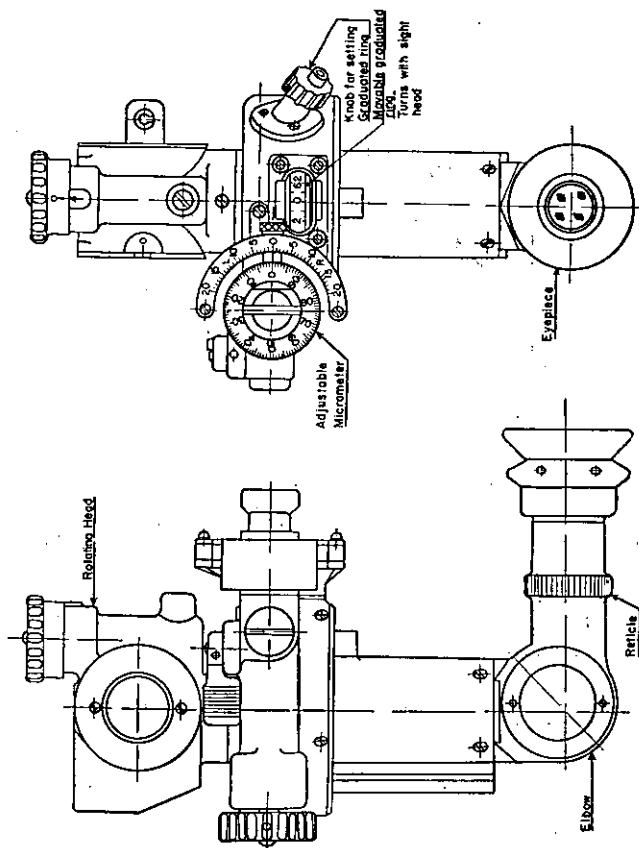

FIGURE 78.—Panoramic telescope M2A1.

were furnished for 155-mm guns—a panoramic telescope for case III pointing and a telescope, M1909A1, for case II, pointing) and may be used for either case II or case III pointing without the necessity of reorienting when changing from one method to the other, a separate micrometer dial being provided for case II settings. The arrangement of scales, indices, and micrometers is indicated in figure 77. Graduations in degrees and hundredths are used.

(2) A list of panoramic telescopes suitable for use with seacoast artillery is given below:

Designation		Cannon mounts	Graduations on scales
New (panoramic telescope)	Old (panoramic sight)		
M2A1.....	M1917MIIA2.....	155-mm.....	Mils.
M3A1.....	M1917MIIA1A3.....	155-mm.....	Degrees.
M4.....	M1917MIIA4.....	155-mm.....	Mils.
M1917MI.....	M1917MI.....	14-inch gun, Railway mount, M1920.	Do.
M1918MII.....	M1918MII.....	Railway and 8-inch barbette, M1918.	Degrees.
M1922.....	M1922.....	Railway and 8-inch barbette, M1918.	Do.
M8.....	None.....	155-mm and 8-inch railway M1.	Do.

NOTE.—Several other models of the panoramic telescope are similar in appearance to some of those listed above but are graduated in the reverse direction and should not be used for seacoast artillery firing. Telescopes should be examined to verify whether or not they are suitable for such use.

c. Adjustment.—(1) *Case II.*—This adjustment of a panoramic telescope consists of boresighting and is theoretically the same as that for the telescopes described in the preceding paragraph.

(a) If the cannon is so emplaced that it may be boresighted on a point at a suitable range (that is, if the range to the point is such that the angle of convergence is less than $\frac{1}{2}$ mil or 0.03° (see par. 179, example *a*)), the adjustment may be made to secure convergence as described in paragraph 172b. This is the normal method of adjustment.

(b) If the guns are emplaced where no suitable point is visible, the adjustment is made to secure parallelism, using normally a testing target. For 155-mm guns such a target is provided by the Ordnance Department. Suitable targets may be constructed for other guns. (A testing target is a chart constructed for the particular combination of gun and sighting equipment with which it is to be used. (See fig. 79.)

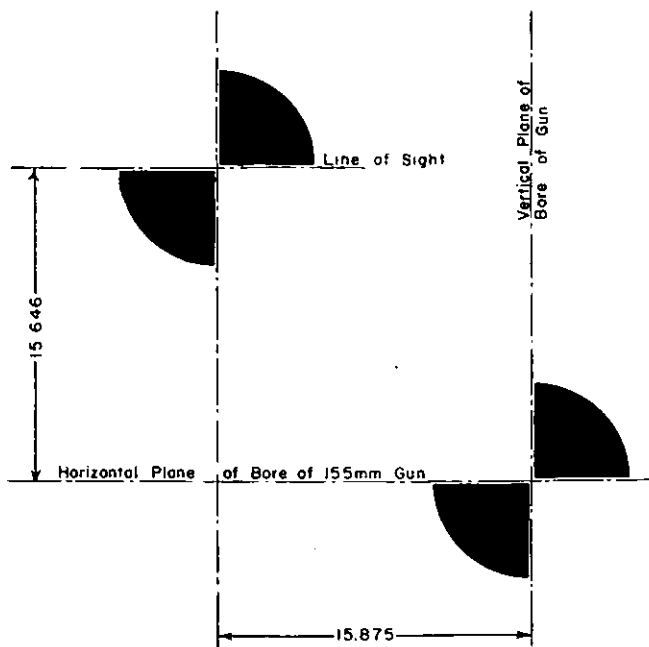

FIGURE 79.—Testing target. 155-mm gun.

(c) Adjustment to secure parallelism may be made also by use of a transit. Set the transit up at some convenient point in front or in rear of the gun. Direct the transit and the gun at each other so that the axis of the bore coincides with the line of sight of the transit. Measure the angle f (fig. 80) with the transit. Direct the gun telescope at the transit and

move it through the angle f' ($=f$). Holding the telescope in this position adjust the azimuth scale and micrometer to read the normal of the deflection reference numbers being used.

NOTE.—The reference mark on the movable limb should now be opposite the fixed azimuth index in the window of the housing, since the line of sight is parallel to the axis of the bore. However, this mark should not be used for adjusting the line of sight unless its own adjustment has been checked by boresighting. (See par. 180, example *a*.)

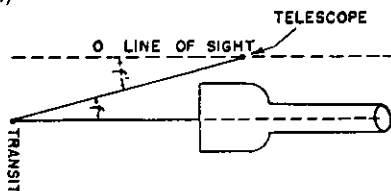

FIGURE 80.—Boresighting a cannon using panoramic telescope.

(*d*) This method of boresighting may be used for the adjustment of telescopes of the type described in paragraph 172, provided the transit can be set up sufficiently distant to accommodate the limited lateral movement of the sight.

(2) *Case III.*—This adjustment consists of orienting the telescope to read the azimuth of the axis of the bore when the telescope is pointed at the aiming point. Having determined the azimuth of the axis of the bore, direct the telescope at the aiming point and adjust the azimuth circle and micrometer to read that azimuth. (See par. 180, examples *b* to *e*, incl.) Methods of determining the azimuth of the axis of the bore are discussed in paragraph 176.

d. Operation.—(1) *Case II.*—The gun pointer sets the deflection received from the plotting room and tracks the target with the vertical cross wire by traversing the cannon, keeping the longitudinal and cross level bubbles centered. The gun pointer may adjust the fire laterally by jumping splashes in the manner described in paragraph 172*d*.

(2) *Case III.*—The gun pointer sets the azimuth received from the plotting room and traverses the cannon until the vertical cross wire is on the aiming point with both bubbles centered.

■ 174. AIMING RULE.—*a. Description.*—The aiming rule (fig. 81) is furnished to mobile seacoast artillery for use as an aiming point. When so used it provides the equivalent of an aiming point at infinity and thereby eliminates errors in pointing due to displacement of the telescope on the cannon. It consists of two upright steel stakes and a connecting bar. The bar provides a path for an adapter which is mounted on it in such a manner that it cannot be rotated about the bar but may be slid along its length. A panoramic telescope is mounted on the adapter. The device is so constructed that if the uprights are vertical and the cross bar horizontal the elbow of the telescope will be maintained in a vertical position. Figure 82 is a horizontal projection showing the geometric principles involved in the use of the aiming rule. *CB* represents the axis of the bore of a cannon with *C* as the pintle center; *A* represents a panoramic telescope mounted on

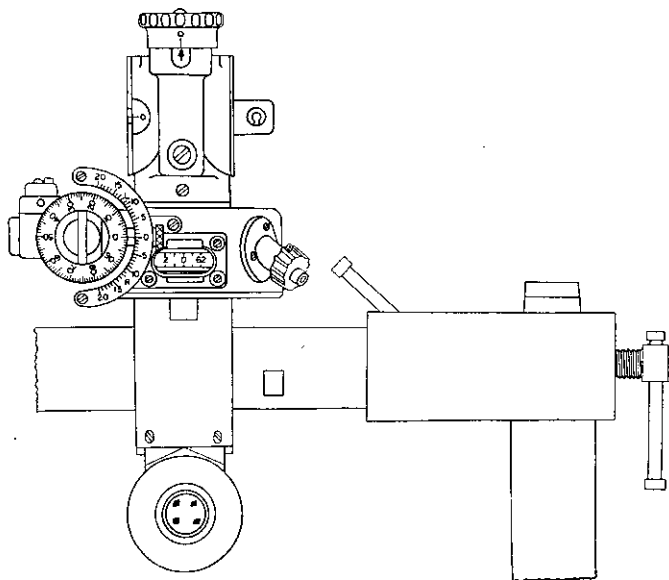

FIGURE 81.—Aiming rule with panoramic telescope.

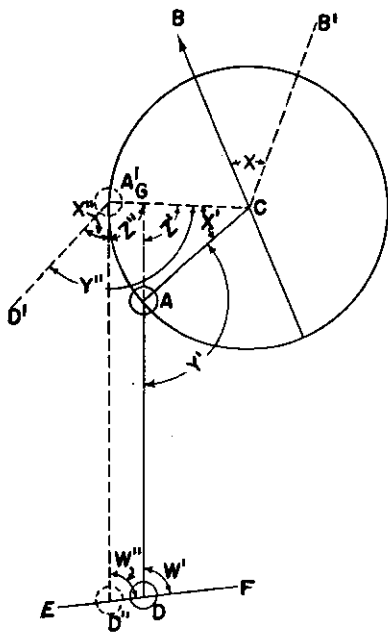

FIGURE 82.—Theory of aiming rule.

the cannon; AD represents the line of sight of the telescope when oriented to read the azimuth of CB . The basic hypothesis is as follows: If the axis of the bore is traversed to any other azimuth, such as CB' , and the telescope is set to read that azimuth, its line of sight, $A'D''$, will always be parallel to its original line of sight at orientation, AD . Let the change of azimuth be the angle X . Then the vertical axis of the telescope will be moved through the angle X' equal to X , since it is traversed with the cannon. Furthermore, since the line of sight has not been moved with respect to the cannon, the angles Y'' and Y' are equal. As stated in the hypothesis, the telescope is now set at the new azimuth of the cannon; that is, the line of sight is moved through the angle X'' , equal to X and to X' .

Proof of hypothesis:

Prolong the line AD to intersect $A'C$ at the point G .

$Z''=Y''-X''=Y'-X'=Z'$, and $A'D''$ is parallel to AD .

The proof holds for all values of X .

This principle is adapted to use by placing the aiming rule in the position EF and the aiming rule telescope at D . In this position the telescope D is pointed at A by rotating the line of sight. At the same time the cannon telescope A is pointed at D and the azimuth scale adjusted to read the azimuth of the axis of the bore CB . The cannon may now be pointed at any azimuth, such as CB' , by the following procedure: Set telescope A at the desired azimuth and point both telescopes at each other, moving the line of sight of A by traversing the cannon and the line of sight of D by sliding D along the aiming rule EF . Since the line of sight of telescope D has not been rotated, the angles W'' and W' are equal and $A'D''$ is parallel to AD .

The aiming rule may be set up at any convenient distance from the cannon within visible range. The rule is not sufficiently long to allow all around fire with a single set-up, and to secure the widest uninterrupted field of fire special attention must be given to the arrangement of the rule. The following general directions apply:

(1) The axis of the bore of the cannon should be pointed approximately at the center of the field of fire when its telescope is oriented.

(2) The aiming rule cross bar should be approximately perpendicular to the line from the cannon telescope to the aiming rule telescope in its orienting position.

(3) The line from the aiming rule telescope in its orienting position to the cannon telescope should be approximately perpendicular to the line from the cannon telescope to the pintle center of the cannon.

(4) The aiming rule telescope should be at the same end of the cross bar as the cannon telescope is at the end of the line from the cannon telescope to the pintle center of the cannon.

If the field is narrow only the first two directions need be followed, in which case the position of the aiming rule

telescope during orientation should be chosen to give the widest movement for the particular set-up.

b. Adjustment.—Traverse the cannon to the desired azimuth for orientation and select the position of the aiming rule according to the directions just given. Set up the aiming rule so that the elbow of the telescope will be held approximately vertical, and place the aiming rule telescope in its selected position on the bar. Both telescopes must remain in these positions until the orientation is completed. The adjustment of the aiming rule telescope is completed by turning the rotating head until the line of sight passes through the cannon telescope. The adjustment of the cannon telescope consists of orienting it on the aiming rule telescope in the same manner as on a fixed aiming point. (See par. 180, example *e* (3).) The adjustment of the aiming rule telescope may be checked independently of the cannon if the following data are recorded when making the original adjustment:

(1) The position of the aiming rule telescope on the cross bar during the original adjustment (by a mark on the cross bar).

(2) The azimuth reading of the aiming rule telescope when pointed at the cannon telescope during orientation.

(3) The azimuth reading of the aiming rule telescope on a fixed reference point. This reference point should be one visible at night as well as in daylight and should be near the line, or near the prolongation of the line, from the aiming rule telescope to the cannon telescope.

With these data the aiming rule telescope may be readjusted independently of the cannon, as long as the aiming rule remains in its original position. Reset the telescope at its original position on the cross bar and point it at the reference point. Check and, if necessary, adjust the azimuth reading. Reset the telescope to the azimuth reading used in the original adjustment.

NOTE.—Although the word "azimuth" has been used in this discussion in connection with both telescopes, the cannon telescope is the only one on which actual azimuths need be set. The readings on the aiming rule telescope may be those which happen to be indicated on the azimuth scale and micrometer.

c. Operation.—The operator of the aiming rule keeps the telescope set at the azimuth used when adjusting and follows the movement of the cannon telescope by sliding his telescope along the aiming rule. The operations of the gun pointer are the same as when a fixed aiming point is used. (See par. 173c(2).)

■ 175. AZIMUTH CIRCLES.—*a. Description.*—Azimuth circles are provided on all fixed seacoast cannon for case III pointing. The circles are graduated in whole degrees and attached to the base ring of the carriage in permanent position. There are two types of indices in common use, both arranged to show the hundredths of a degree of azimuth. One type employs a movable index which is set by means of a micrometer screw with a subscale on its head. The other type consists of a subscale fixed to the racer opposite which the whole degree graduation on the azimuth circle is set to the hundredths on the subscale.

b. Adjustment.—(1) *Orientation.*—The azimuth circle is oriented when the cannon is installed, but the index or subscale is movable for minor adjustments. The adjustment on an azimuth circle consists of orienting it and the index to read the azimuth at which the axis of the bore is pointing. (See par. 179, example b.)

(2) *For convergence.*—In special situations, the cannons of a fixed battery may be adjusted to converge on a central point in the field of fire. If this result is desired, the adjustment consists of making the azimuth circles of each cannon read the same azimuth when directed at the point of convergence. This adjustment may be made either with the aid of a bore-sight or by computation. (See par. 179, example c.)

c. Operation.—(1) *Movable index and micrometer screw.*—The azimuth setter sets the hundredths of a degree on the micrometer screw subscale and traverses the cannon until the index is opposite the whole degree graduation mark on the azimuth circle.

(2) *Fixed subscale.*—The azimuth setter traverses the cannon until the whole degree graduation mark on the azimuth circle is opposite the hundredths of a degree on the subscale.

■ 176. DETERMINATION OF AZIMUTH OF AXIS OF BORE.—*a.* (1) *Cannon pointed at a datum point.*—The simplest way to point a cannon at a known azimuth is by direct observation along the axis of the bore at a datum point of known azimuth. The observation is made by means of a boresight and a thread held against the muzzle at its vertical diameter. In some cases the operation is made easier by using the vent in the breechblock instead of the boresight. (See par. 180, example *b.*)

(2) *Cannon pointed at a transit.*—If the cannon is so emplaced that it cannot be pointed at a permanent datum point, as in the case of a fixed mortar, a temporary datum point may be set up. This consists of a transit set up over a point visible from the mortar and from which a line of known azimuth may be established. It may be possible to establish this line by pointing the transit at a datum point whose azimuth from the transit position is known. If not, an oriented azimuth instrument may be pointed at the transit and the back azimuth of that line taken. Next, measure the angle between that orienting line and the line from the transit through the pintle center of the mortar. The latter line is located by pointing the transit and the mortar at each other so that the axis of the bore coincides with the line of sight of the transit. The angle combined with the azimuth of the orienting line will give the back azimuth of the axis of the bore. (See par. 179, example *b.*, and par. 180, example *e.*)

b. (1) *Telescope pointed at a datum point.*—If a cannon equipped with a panoramic telescope is so emplaced that it cannot be pointed at a datum point at which the telescope can be pointed, the azimuth of the axis of the bore may be determined by measuring with the telescope the angle between the line of sight to the datum point and the line through the telescope parallel to the axis of the bore. The procedure is as follows:

Boresight the cannon and telescope to establish parallelism and record the reading of the telescope. Direct the telescope at the datum point and record the reading. From the recorded data compute the azimuth at which the axis of the bore is pointing.

In practice, the operation is usually done by setting the azimuth of the datum point on the telescope while the line of sight is parallel to the axis of the bore. If the telescope is then pointed at the datum point, the indicated reading will be the azimuth of the axis of the bore. (See par. 180, examples *c* and *e* (2).)

(2) *Telescope pointed at a transit.*—If a cannon equipped with a panoramic telescope is so emplaced that neither the cannon nor the telescope can be pointed at a permanent datum point, a combination of the methods in *a*(2) and *b*(1) may be used. Determine the angle at the transit between the oriented azimuth instrument (or datum point) and the telescope, and the angle at the telescope between the transit and the line of sight when it is parallel to the axis of the bore. These angles combined with the azimuth from the transit to the azimuth instrument will give the back azimuth of the axis of the bore. (See par. 180, example *e*.)

After the original orientation has been completed, steps should be taken before the axis of the bore is moved to determine suitable data for checking the orientation without the use of a transit. This may be done by determining the azimuth of a fixed reference point at least 1,000 yards from the cannon on which the orientation may be checked by the method given in *b*(1) above.

SECTION IV

EXAMPLES OF POINTING ADJUSTMENTS

■ 177. ADJUSTMENTS IN ELEVATION FOR FIXED ARTILLERY.—
Example a.—A battery of 12-inch seacoast guns, M1895, on 12-inch barbette carriage, M1917, firing a 975-pound projectile (Firing Tables 12-F-3), is emplaced with a field of fire from 130° to 210° in azimuth and from 12,000 to 25,000 yards in range. During the preparation for a target practice, the emplacement officer checks the level of the base rings of the

guns by means of a clinometer set initially at 10' of elevation. The results of the check are as follows:

Azimuth	No. 1	No. 2
°	'	'
130	10	10
145	8	10
160	6	10
175	4	10
190	4	8
210	6	6

First requirement.—The azimuths at which the range disks should be adjusted for zero correction.

Second requirement.—The base ring corrections at other azimuths for each gun, in both elevation and range.

Solution, first requirement.

No. 1—160° azimuth.

No. 2—Any azimuth between 130° and 175°.

Solution, second requirement.—The base ring corrections in minutes of elevation may be computed from the data recorded during the check of level. These corrections are tabulated below. The next step is to extract the necessary data from Firing Tables 12-F-3 by which the angular corrections may be converted into linear corrections. These data are as follows:

Range (yards)	Change in range for 1 minute change in elevation (yards)
12,000	18.6
25,000	9.2

The base ring corrections in yards may now be computed by multiplying the mean change in yards for 1 minute change

in elevation by the correction in minutes. The product is taken to the nearest 10 yards.

Azimuth	No. 1		No. 2	
	Angular correction	Linear correction (yards)	Angular correction	Linear correction (yards)
°	'		'	
130	-4	-60	None	None
145	-2	-30	None	None
160	None	None	None	None
175	+2	+30	None	None
190	+2	+30	+2	+30
210	None	None	+4	+60

NOTE.—The errors in the level of this base ring are excessive.

Example b.—The range disks of the guns referred to in example *a* are checked for adjustment at 160° azimuth and the following data recorded:

Elevation set on clinometer	Range reading on disk (yards)	
	No. 1	No. 2
° ' "		
8 21	12,040	12,000
14 36	18,030	18,000
24 54	25,020	25,000

The elevation tables for this battery contain the following data:

Range (yards)	Angle of elevation
	° ' "
12,000	8 21
18,000	14 36
25,000	24 54

First requirement.—Conclusions drawn as a result of the check of the range disks.

Second requirement.—Action recommended to correct errors.

Solution, first requirement.—The range disk on No. 1 gun is in error by approximately 2 minutes of elevation; the gun would be pointed too low. The range disk on No. 2 gun is in adjustment.

Solution, second requirement.—The range disk on No. 1 gun should be adjusted by making it read the range corresponding to the angle of elevation of the axis of the bore. The adjustment may be made at any convenient elevation.

■ 178. ADJUSTMENTS IN ELEVATION FOR MOBILE ARTILLERY.—

Example.—A battery of two 8-inch seacoast guns, M1888, on railway mount, M1918, is emplaced for the defense of a channel that lies between the ranges of 8,000 and 15,000 yards. The guns are equipped with M1917 elevation quadrants. The quadrants were checked for accuracy with the following results:

Approximate range (yards)	Elevation set on clinometer	Quadrant reading	
		No. 1	No. 2
8,100	11 00	10 57	11 05
11,500	20 00	19 57	20 01
14,800	33 00	32 57	32 56

First requirement.—Conclusions drawn as a result of check.

Second requirement.—Detailed explanation of any adjustments made on the quadrants to correct errors.

Solution, first requirement.—The quadrant on No. 1 gun is out of adjustment by 3 minutes of elevation; the gun would be pointed too high. The quadrant on No. 2 gun is damaged and should be turned in to the ordnance officer for repair.

Solution, second requirement.—The quadrant on No. 1 gun may be adjusted to read correct quadrant elevations by either of two methods as follows:

a. By angle of site mechanism.—Set an angle of site correction of $2^{\circ}57'$ and relevel the longitudinal bubble by operating the elevation micrometer screw. Check the reading of the quadrant; it should now read the same as the clinometer.

b. By displacing elevation disk and micrometer.—Loosen the locking nuts and displace the elevation disk and micrometer by the necessary amount to make them indicate the reading of the clinometer.

■ 179. ADJUSTMENTS IN DIRECTION FOR FIXED ARTILLERY.—

Example a.—The vertical axis of the telescope on a 6-inch seacoast gun, M1903, on disappearing carriage, M1905MI, is approximately 1.4 yards to the left of the axis of the bore. The sight is adjusted by boresighting for convergence on a datum point 6,000 yards from the gun.

Required.—The amount of the angular error introduced into the pointing.

Solution.—The angular error introduced into the pointing corresponds to the angle f in figure 80.

$$\tan f = \frac{1.4}{6000} = 0.00023$$

$$f = 0.013^{\circ}$$

Example b.—A battery of four 12-inch mortars, M1890, on fixed mortar carriages, M1896MI, is emplaced in two mortar pits, with two mortars per pit. The four mortars are all on a straight line with an interval of 8 yards between the mortars in each pit and 30 yards between the pits. The directing point is on the same line midway between the pits but, being on the parapet above the mortars, is invisible from the pits. An oriented azimuth instrument is mounted over the directing point. The center point of the field of fire is at 6,000 yards range and 125.75° azimuth from the directing point. This line is perpendicular to the line through the mortars. It is desired to orient the azimuth circles on the mortars.

Required.—An explanation of the procedure for orientation.

Solution.—Set up a transit on the parapet near A pit and determine the angle between the directing point and each gun. Also direct the azimuth instrument at the transit and read the azimuth. Repeat the procedure for B pit. Assume that the azimuths and angles determined are as shown in figure

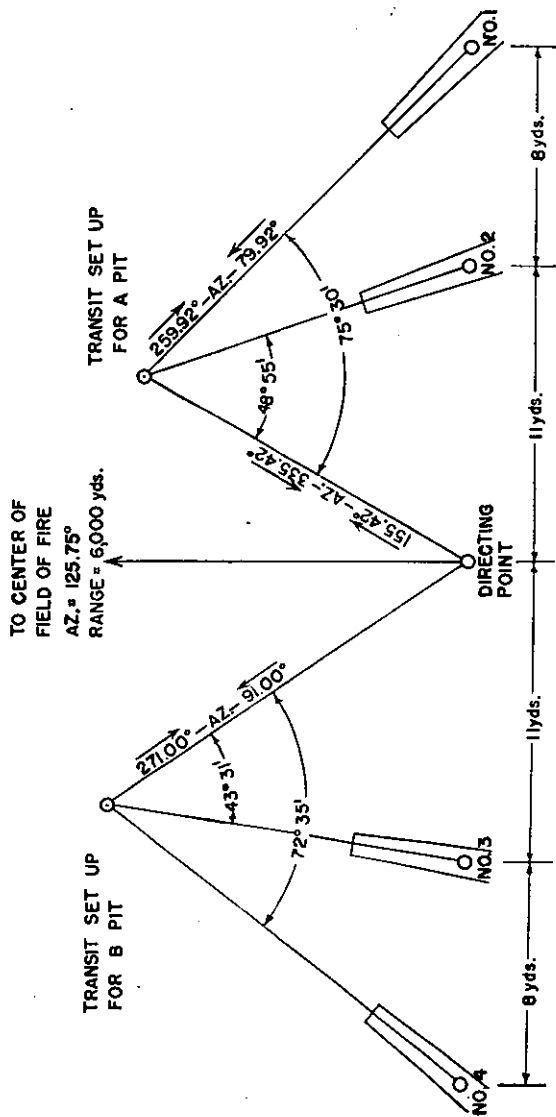

FIGURE 83.—Orientation of azimuth circles by transit (par. 179, example b).

83. From the recorded data compute the azimuth at which the axis of the bore of each mortar is pointing. The computations are as follows (transit readings have been changed to degrees and hundredths):

Mortar No.	Azimuths				
	D. P. to transit	Transit to D. P.	Azimuth difference between D. P. and mortar	Transit to mortar	Mortar to transit
	°	°	°	°	°
1	155.42	335.42	-75.50	259.92	79.92
2	155.42	335.42	-48.92	286.50	106.50
3	91.00	271.00	+43.52	314.52	134.52
4	91.00	271.00	+72.58	343.58	163.58

The orientation is completed by adjusting each azimuth circle to read the azimuth of the axis of the bore.

Example c.—The orientation of the mortars referred to in example *b* is completed. It is now decided to adjust the azimuth circles so that when all the mortars are set at 125.75° azimuth the two mortars in each pit will be pointed parallel and the two pits will converge on the center point of the field of fire.

Required.—The amount and direction of the convergence correction to be applied to each mortar and the method of application.

Solution.—The amount of the convergence necessary for each pit in order that the two pits may converge at the center of the field of fire is equal to the parallax angle subtended at the center of the field of fire by one-half the distance between the pits. The same convergence correction must be applied to each mortar in the same pit in order that they may remain parallel. The direction of the convergence correction may be determined by inspection of figure 83. Nos. 1 and 2 in *A* pit must be moved to the left, and Nos. 3 and 4 in *B* pit must be moved to the right.

The computations are as follows:

$$\text{tangent of the parallax angle} = 15/6000 = 0.0025$$

$$\text{parallax angle} = 8'36'' = 0.14^\circ$$

The convergence corrections are—

No. 1—left 0.14° .

2—left 0.14° .

3—right 0.14° .

4—right 0.14° .

The corrections may be applied with the mortar pointed at any azimuth.

The adjustment of the mortars in *A* pit may be made as follows: Assume that the mortar is pointing at 79.92° azimuth. Adjust the azimuth index to read $79.92^\circ + 0.14^\circ = 80.06^\circ$. If the mortar is now traversed until the original azimuth, 79.92° , is set, the axis of the bore will be pointing 0.14° to the left of that azimuth. The mortars in *B* pit may be adjusted by making the azimuth circle indicate 0.14° less than the actual azimuth.

NOTE.—In practice, this adjustment would be combined with the check of orientation discussed in example *b*. Instead of displacing the azimuth indices to read the actual azimuths of the bores displace them to read the adjusted azimuths as follows:

No.	Actual azimuth	Adjusted azimuth
	°	°
1	79.92	80.06
2	106.50	106.64
3	134.52	134.38
4	163.58	163.44

■ 180. ADJUSTMENTS IN DIRECTION FOR MOBILE ARTILLERY—

Example a.—The panoramic telescope on a 155-mm gun is being boresighted for case II pointing by a transit set up in front of the gun as shown in figure 84. The parallax angle is found to be $5^\circ 51'$ or 104 mils. The normal of the deflection reference numbers being used is 600. Therefore, it is desired to adjust the azimuth scale to read 600 mils when the line

of sight is parallel to the axis of the bore. The telescope is pointed at the transit and reads 496 mils.

Required.—Is the telescope in adjustment?



FIGURE 84.—Boresighting by transit (par. 180, example a).

Solution.—The telescope is in adjustment. The deflection setting of 496 mils is, according to the rule, "Right, Raise; Left, Lower," equivalent to a deflection of left 104 mils which agrees with the conditions shown in figure 84.

Example b.—An 8-inch railway gun equipped with a panoramic telescope is pointed by boresight at a distant datum

point at 330.26° azimuth (zero *S*). An aiming point of unknown azimuth has been selected for use in case III pointing.

Required.—The orientation of the telescope for case III pointing.

Solution.—Point the telescope at the aiming point and adjust the azimuth circle and micrometer to read the azimuth of the axis of the bore, 330.26° .

Example c.—A 155-mm gun equipped with a panoramic telescope M3A1 is so emplaced that it cannot be pointed at an instrument or point of known azimuth. The telescope has been adjusted so that when the reference mark on the

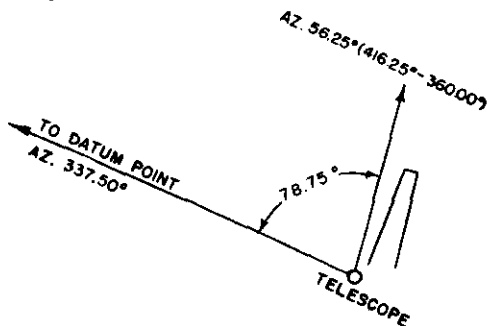

FIGURE 85.—Determination of azimuth of cannon by telescope and datum point (par. 180, example c).

limb is opposite the fixed azimuth index the line of sight is parallel to the axis of the bore. The azimuth to a datum point at which the telescope can be pointed is 337.50° . The reading on the telescope when the line of sight is parallel to the axis of the bore is 112.50° . The telescope is pointed at the datum point and reads 191.25° .

Required.—The azimuth of the axis of the bore.

Solution.—The readings of a panoramic telescope increase as the line of sight is moved to the left. Therefore, the axis of the bore is 78.75° to the right of the line of sight to the datum point. The azimuth of the axis of the bore is 56.25° . (See fig. 85.)

Example d.—Continuing the situation in example c above, the datum point is to be used as an aiming point for case III pointing.

Required.—The azimuth reading that should be set on the telescope to complete the orientation.

Solution.—The azimuth reading should be the azimuth of the axis of the bore, 56.25° .

Example e.—(1) A 12-inch seacoast mortar on railway mount is being oriented for case III pointing. The azimuth of the axis of the bore is unknown, and there is no datum

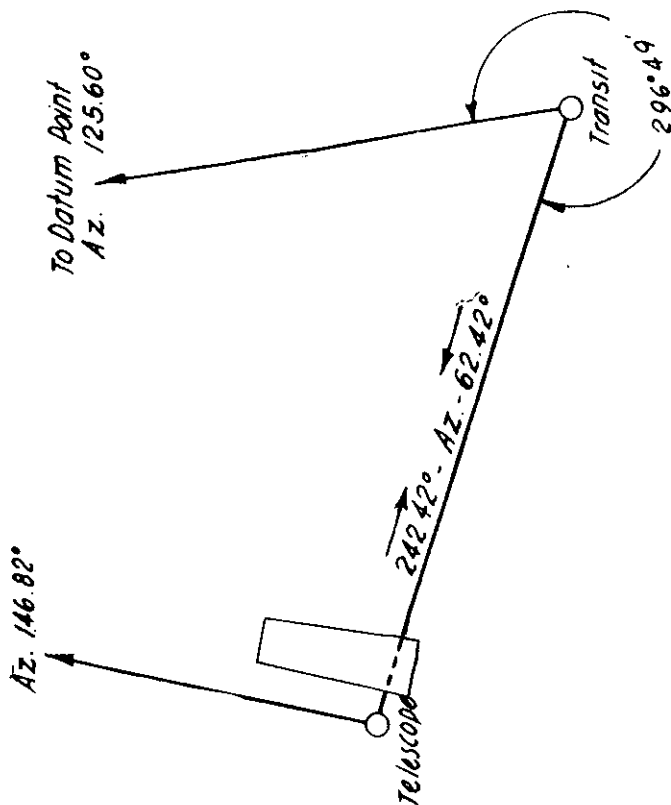

FIGURE 86.—Determination of azimuth of cannon by transit and telescope (par. 180, example e).

point visible from the mortar or the panoramic telescope with which it is equipped. There is, however, a position visible from the mortar position from which the azimuth to a visible datum point is known. That azimuth is 125.60° (zero *S*). A transit is set up over this position and the following records made:

<i>A vernier reading</i>	
Transit pointed at datum point.....	27°36'
Transit pointed at telescope.....	324°25'
<i>Required.</i> —The azimuth of the transit from the telescope.	
<i>Solution.</i> —This example is illustrated in figure 86.	
Difference between transit readings.....	296°49'
	296.82°
Azimuth from transit to datum point.....	125.60°
	422.42°
Subtract.....	360.00°
	62.42°
Azimuth of telescope from transit.....	62.42°
Add	180.00°
	242.42°
Azimuth of transit from telescope.....	242.42°

(2) The line of sight of the telescope is placed parallel to the axis of the bore and the azimuth circle adjusted to read the azimuth to the transit. It is then directed at the transit and reads 146.82° .

Required.—The azimuth of the axis of the bore.

Solution.—The azimuth of the axis of the bore is the azimuth indicated by the telescope or 146.82° .

(3) With the axis of the bore at the same azimuth, 146.82° , the telescope is to be oriented for case III pointing, using an aiming rule set up in rear of the mortar. (See fig. 87.) The aiming rule telescope is placed in its orienting position, as shown in the figure, and the two telescopes are directed at each other.

Required.—The correct azimuth setting that should be made on each telescope to complete the adjustment.

Solution.—The setting on the mortar telescope should be the azimuth of the axis of the bore, 146.82° . The setting

on the aiming rule telescope is immaterial. It may be any setting that happens to be indicated. (The setting should, however, be recorded as well as one on a distant reference point for use in readjusting the aiming rule telescope.)

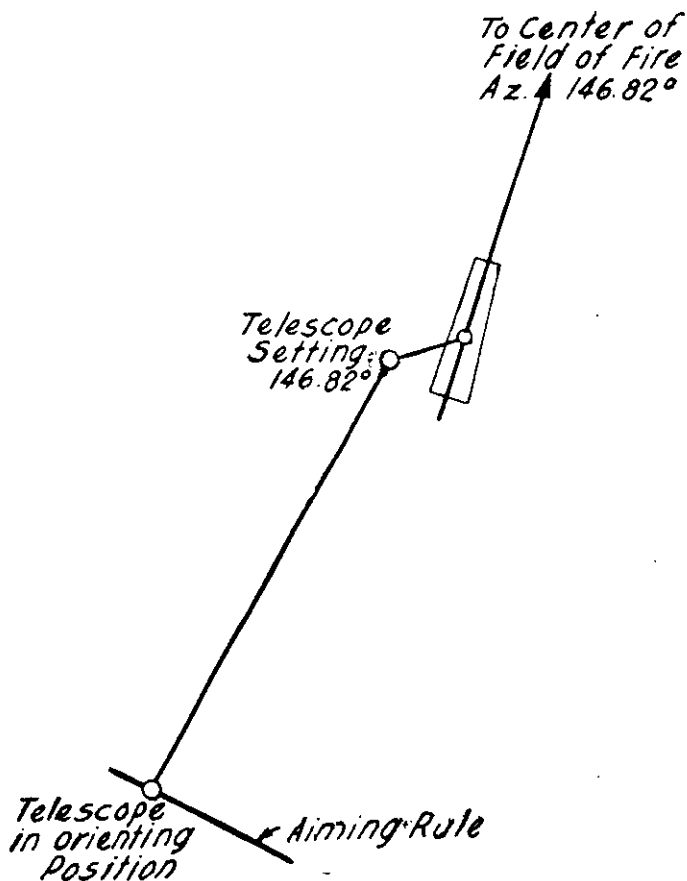

FIGURE 87.—Orientation of aiming rule.

CHAPTER 18

FIRE CONTROL COMMUNICATION

■ 181. COMPOSITION OF FIRE CONTROL COMMUNICATION SYSTEM.—The fire control communication system of a unit is composed of those means by which the unit commander transmits orders and information pertaining to the control of fire, and through which technical information, position finding data, and firing data are sent between subdivisions of the unit. Means normally employed are those described in paragraphs 182 to 188, inclusive.

■ 182. WIRE SYSTEM (TELEPHONE).—This is the most important means of fire control communication provided. It is the principal means of transmitting position finding data from observation stations to the plotting room or the plotting car and of transmitting firing data to the guns. Its greatest advantage lies in the fact that it affords immediate and personal transmission of speech between individuals.

■ 183. RADIO SYSTEM (TELEPHONE AND TELEGRAPH).—Radio is an important auxiliary to the telephone. It is used to communicate with aircraft assigned for aerial position finding or for fire adjustment.

■ 184. VOICE TUBES.—These are metal tubes or pipes with a flare similar to a megaphone at each end. They are employed in fixed seacoast artillery only and are used to transmit direct conversation between nearby elements such as the battery command station, the plotting room, the gun emplacement, and the magazines.

■ 185. MECHANICAL DATA TRANSMITTERS.—Some batteries are equipped with mechanical data transmitters designed to transmit data from the plotting room to emplacements and magazines. These systems have had little use in recent years, the telephone system being used instead.

■ 186. DATA TRANSMISSION SYSTEM M5 (electrical) (formerly T11).—*a. General.*—The use of an electrical data transmis-

sion system reduces the chances of error by eliminating some of the "read and set" operations involved in other systems. The M5 system provides means for electrically transmitting azimuths and elevations from plotting room to "match the pointer" indicators on gun mounts. This system is approved for issue on the basis of one complete unit per battery of 8-inch caliber or above, mounted on barbette carriage (except 8-inch B. C., M1918). A complete unit is composed of one azimuth transmitter (fig. 88), one elevation transmitter (fig. 89), one azimuth indicator per gun (fig. 90), one elevation indicator per gun (fig. 91), and the necessary armored and flexible cables, junction and distribution boxes, and A. C. power supply. A. C. power is furnished either by a gasoline electric generator unit M3 or a D. C.-A. C. rotary converter.

b. Description of complete unit.—(1) The azimuth transmitter (fig. 88) is located in the plotting room and consists primarily of one set of generator units for each of two guns. Each set consists of two units, one coarse and one fine. One revolution of the coarse azimuth dials (1) is equivalent to 360°, and these dials are graduated and numbered every 10° from 0° to 360°. One revolution of the fine azimuth dials (2) is equivalent to 10°, and these dials are graduated from 0° to 10° in 0.05° divisions and numbered every 0.1°. Each unit of the parallax counters (3) represents 0.01°. The counters may be set to indicate, at the zero position, any desired number for any particular system of reference numbers. Azimuths are set on the azimuth dials by the input handwheel (4). Parallax corrections are set on the parallax counters (3) by means of knobs (6) and are added algebraically to the input azimuths by means of differentials. The resulting azimuths, called the transmitted azimuths, are indicated on dials which are directly connected to the transmitting generators by which they are transmitted continuously to the indicators on the gun mounts. The transmitters are provided with a ready signal consisting of two red bull's-eyes which are illuminated by lamps wired in parallel with corresponding signal lamps on the gun mounts. The ready signal is controlled by the signal switch. A 35-foot length

of multiconductor cable (5) is provided with a plug at one end for connecting to a receptacle in the plotting room.

(2) The elevation transmitter (fig. 89) is practically identical in construction with the azimuth transmitter except that the unit of graduation is the mil instead of the degree. The coarse dials of this instrument rotate at one-fourth the speed of the coarse dials of the azimuth transmitters, that is, one revolution represents 1,600 mils' elevation. The coarse elevation dials (1) are graduated from 0 to 1,600 mils in 100-mil divisions and numbered every 100 mils. The fine dials (2) are graduated from 0 to 100 mils in 1-mil divisions

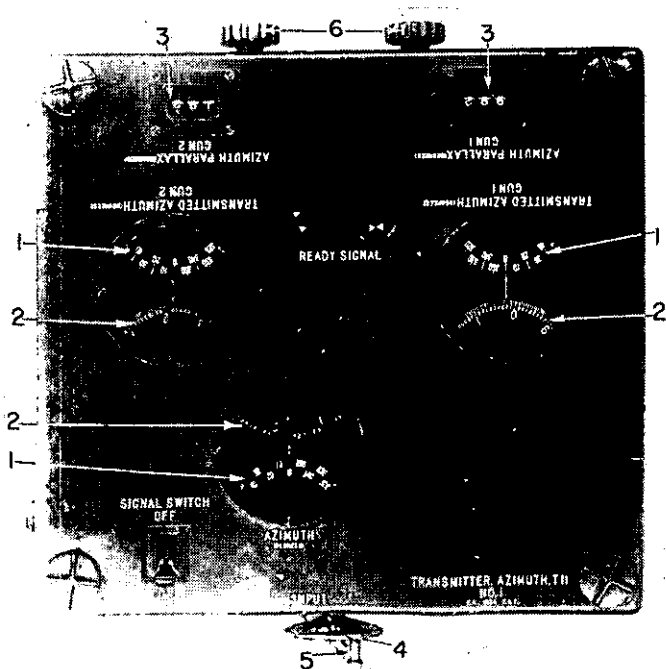

FIGURE 88.—Azimuth transmitter, data transmission system M5 (T11).

and numbered every 10 mils. The elevation set into the instrument is indicated both on a counter (7) and on the input dials.

(3) The azimuth indicator (gun mount) (fig. 90) is mounted on the side of the gun carriage. It employs two self-synchronous motor units for positioning a coarse dial indicating 360° per revolution and a fine dial, 10° per revolution. Index

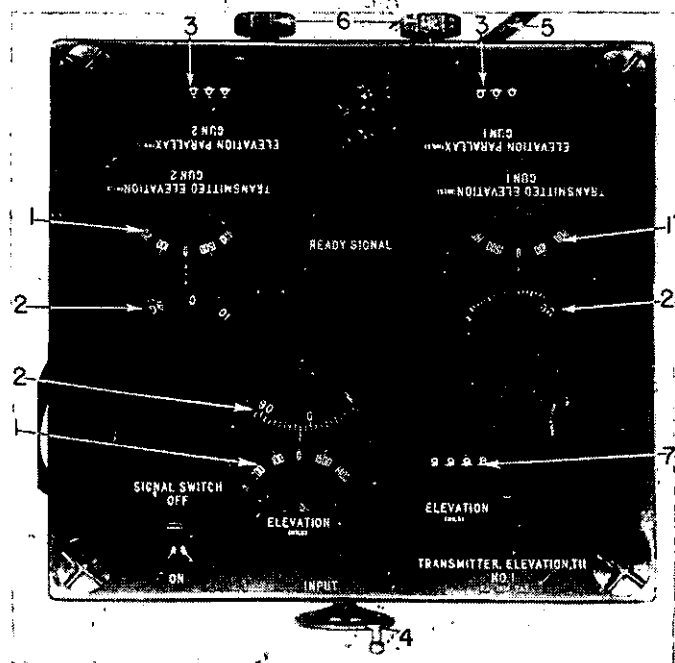

FIGURE 89.—Elevation transmitter, data transmission system M5 (T11).

pointers (1) mechanically geared to the traversing mechanism of the gun rotate concentrically with each motor dial (2) and a fixed scale graduated from 0° to 360° for the coarse dial (3) and from 0° to 10° for the fine dial (4). A ready signal lamp is mounted behind a red bull's-eye (5) between the dials. The

entire mechanism is inclosed in a weatherproof case provided with shatterproof glass windows.

(4) The elevation indicator (fig. 91) is practically identical in construction with the azimuth indicator except that the

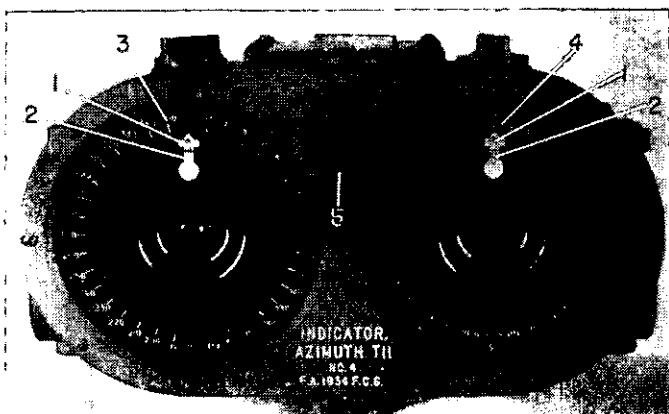

FIGURE 90.—Azimuth indicator, data transmission system M5 (T11).

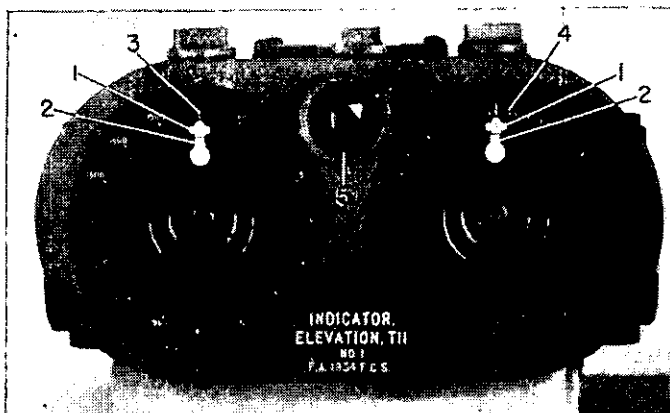

FIGURE 91.—Elevation indicator, data transmission system M5 (T11).

unit of graduation of the dials is the mil instead of the degree. The coarse dial (2) is graduated from 0 to 1,600 mils in 100-mil divisions and numbered every 100 mils. The fine dial (3) is graduated from 0 to 100 mils in 1-mil divisions and numbered every 10 mils.

c. *Precision of transmission.*—Each transmitter is capable of controlling its indicator motors to a precision of $\frac{1}{2}^{\circ}$. This is equivalent to $\frac{1}{2} \times 1/360 \times 10 = 0.014^{\circ}$ for the fine motor of the azimuth indicator and $\frac{1}{2} \times 1/360 \times 100 = 0.14$ mil for the fine motor of the elevation indicator.

d. *Synchronization of mechanical pointers.*—(1) *Azimuth.*—The mechanical azimuth pointers are in synchronization when they indicate the azimuth at which the bore of the gun is pointing. The azimuth of the bore may be obtained either from the azimuth scale of the gun, provided it has been adjusted previously, or by boresighting the gun on a datum point whose azimuth is known. To adjust the mechanical pointers to read the azimuth of the bore, an adjustable coupling is provided. The coupling has two screws, the clamping screw that locks the device and the adjusting screw which actuates a worm wheel on the shaft and provides micrometer adjustment to the mechanical pointers. By means of a screw driver the mechanical pointers may be synchronized to read the azimuth of the bore.

(2) *Elevation.*—The mechanical elevation pointers are in synchronization when they indicate the quadrant elevation of the axis of the bore. The quadrant elevation of the bore is obtained by use of either a quadrant or a clinometer. The mechanical elevation pointers are provided with the same type of adjustable coupling as the mechanical azimuth pointers and may be synchronized in the same way.

e. *Synchronization of electrical pointers.*—The electrical pointers for azimuth and those for elevation are synchronized in the same manner. They should indicate on the guns the same data that are set in the transmitters in the plotting room. If there is a constant difference between the data sent and the data received, synchronization may be accomplished on the indicators on the guns by the following method: Remove the plugs on the top of the case to gain access to the

adjustable coupling which is similar to the one installed with the mechanical pointers. With the system energized loosen the clamping screw, using the special wrench provided. Rotate the dial to the correct position by turning the adjusting screw with the same wrench.

f. Operation.—The operation of the system requires the following personnel:

- (1) At the azimuth transmitter—
 - 1 azimuth setter (input).
 - 1 parallax (gun displacement) correction setter.
- (2) At the elevation transmitter—
 - 1 elevation setter (input).
 - 1 parallax (gun displacement) correction setter.
- (3) At each gun emplacement—
 - 1 azimuth pointer matcher (at azimuth indicator).
 - 1 elevation pointer matcher (at elevation indicator).

With the data transmission system in synchronization, data are set on the transmitters in the plotting room and the ready signals turned on. At the guns the operators by means of a traversing and elevating handwheels first roughly match the coarse dials and then exactly match the fine dials.

NOTE.—Descriptions of the cable system, junction and distribution boxes; description and instructions for operation of the gasoline electric generating unit and of the rotary converter; and instructions for maintenance are contained in publications by the Ordnance Department.

■ 187. **ELECTRICAL SIGNAL SYSTEMS.**—These systems provide means of indicating time simultaneously at various stations (time interval apparatus) and of transmitting firing signals.

■ 188. **VISUAL SIGNAL DEVICES.**—Visual signals are employed when other means for the transmission of messages have failed, and as an auxiliary means of transmitting over relatively short distances certain prearranged signals or short messages. Visual signaling equipment includes—

a. Panels.—Used for communication from the ground to airplanes when the radio system is not available during the conduct of fire.

b. Signal lamps (projectors).—Employed in an emergency to transmit short messages between small elements of the command.

c. Pyrotechnics.—Utilized principally for sending prearranged emergency signals. Among these is the Very pistol, used in exceptional cases for communication to and from airplanes, especially at night.

d. Flags.—Used to transmit prearranged signals at the firing position or between emplaced guns at the battery when other means are not available. Arm signals may be similarly employed.

NOTE.—Description of communication equipment and information as to its procurement, installation, maintenance, and operation are contained in FM 24-5, in Technical Manuals, and in other publications. For operation and maintenance of the equipment, each battery except a battery of tractor drawn artillery has a communication section. A battery of tractor drawn artillery has a communication detail which is a part of the operations section.

CHAPTER 19

ORGANIZATION AND DUTIES OF RANGE SECTION AND OF OTHER BATTERY FIRE CONTROL PERSONNEL

	Paragraphs
SECTION I. Range section, general.....	189-191
II. Duties of range section details.....	192-194
III. Other battery fire control personnel.....	195-197
IV. Training.....	198-206

SECTION I

RANGE SECTION, GENERAL

■ 189. **DEFINITION.**—The range section of a battery is that subdivision of the personnel of the battery in which is centered the function of fire control. It is under the immediate command of the range officer and generally consists of the observing details, the spotting details, and the plotting room details.

NOTES.—1. See paragraph 190b.

2. In a battery of tractor drawn artillery the fire control personnel are a part of the reconnaissance detail of the operations section.

■ 190. **ORGANIZATION.**—*a. All except rapid fire batteries.*—(1) *Observing details.*—Each observing detail is assigned to a particular observation station (B^1 , B^2 , etc.) and is composed of the observer and the reader.

(2) *Spotting details.*—Each spotting detail is assigned to a particular spotting station (S^1 , S^2 , etc.) and is composed of the spotting observer and the spotting reader. The reader may be omitted where the observer reads deviations from an internal scale.

(3) *Plotting room detail.*—(a) Where the plotting room is equipped with a Whistler-Hearn or with a 110° plotting board, the plotting room detail will be composed of the following personnel (the numbers refer to the numbered designation of each member of the detail):

Plotter.

No. 1, angular travel device operator (case II) or gun arm azimuth reader (case III).

- No. 2, primary arm setter.
- No. 3, secondary arm setter.
- No. 4, range correction board operator.
- No. 5, set-forward device operator.
- No. 6, percentage corrector operator.
- No. 7, deflection board operator.
- No. 8, assistant deflection board operator (note 1).
- No. 9, fire adjustment board operator, (an officer, if available).
- No. 10, spotting board operator (note 2).
- Nos. 11 and 12, assistant spotting board operators (note 2).
- No. 13, data transmission device operator (note 3).
- Nos. 14 and 15, recorders (note 4).

NOTES.—1. No. 8 is used only with the deflection board M1.

2. Where airplane observation of the fall of shots is provided, the use of the spotting board may become unnecessary. In such cases Nos. 10, 11, and 12 become unnecessary and may be eliminated. With some spotting boards only one assistant is necessary.

3. If the battery is not equipped with a data transmission device, No. 13 will be eliminated. Where the data transmission system M5 is used, four operators are required. (See par. 186.)

4. Recorders in such numbers as are necessary to insure complete and accurate records for the purpose of drill and target practice analyses must be provided. Nos. 14 and 15 are provided as regularly assigned members of the plotting room detail. When they are not required for recording purposes they may be given other duties. Operators of instruments will record their own data when practicable.

(b) Where the plotting room is equipped with plotting and relocating board M1923 (Clope), the plotting room detail will be composed of the following personnel (the numbers refer to the numbered designation of each member of the detail):

Plotter.

Platen operator.

No. 1, angular travel device operator (case II only). (Not needed when deflection board M1 is used.)

No. 2, plotting arm setter.

No. 3, Relocating arm setter.

Nos. 4 to 15, inclusive (same as plotting room detail, (a) above).

b. *Rapid-fire batteries*.—In a rapid-fire battery not provided with a plotting room, where corrections to firing data are usually made and applied in the battery commander's station, the range section ordinarily is combined with the

additional personnel enumerated in section III. The combined unit consists of the following personnel:

Observer, battery commander's (azimuth).

Observer, self-contained range finder.

Observer, spotting.

Reader, battery commander's.

Reader, self-contained range finder.

Reader, spotting (often unnecessary).

Range correction ruler or range percentage corrector operator.

Deflection board operator.

Fire adjustment board (or over short adjustment chart) operator.

Transmission device or display board operator (if necessary).

Telephone operators, one for each phone.

Recorder.

■ 191. DUTIES, GENERAL.—*a.* Prior to drill, practice, or action, after details have been posted, each member of the range section examines, adjusts, and tests the functioning of the particular device or apparatus operated by him. After determining whether it is in satisfactory condition for service, each reports to his chief of detail as, "Sir, No. 6, percentage corrector in order," or reports any defects which cannot be corrected without delay.

b. Each member of the range section is responsible at all times for the care, adjustment, condition, and serviceability of the device, instrument, or apparatus operated by him. Where a single device is common to more than one member of the range section, as in the case of the spotting board, the chief of the detail is responsible.

c. At the conclusion of drill, practice, or action, the battery commander commands: **BATTERY DISMISSED**. The range officer commands: **CLOSE STATIONS**, and each of the position finding personnel makes secure his device or instrument. Chiefs of details supervise the replacing of equipment and the police of stations.

d. Description of the detailed operation of position finding apparatus are included in chapters 7 to 14, inclusive.

SECTION II

DUTIES OF RANGE SECTION DETAILS

■ 192. OBSERVING DETAILS.—*a. Observer.*—The observer is responsible to the range officer for the care, adjustment, and use of his instrument, for the police of his station, and for the functioning of his detail. Upon arrival at his station he makes a careful inspection and examination, orients his instrument, tests the means of communication, and reports to the plotter, "B¹ (of B², etc.) in order," or reports such defects as he is unable to remedy without delay. When the target has been indicated by the battery commander and identified by the observer, the latter reports, "B¹ (or B², etc.) on target"; and when the battery commander has given the command TRACK, the observer follows the target with his instrument, keeping the cross wires thereof accurately centered on the observing point on the target. When the third bell of each time interval signal strikes, he stops following the target long enough to permit his reader to read and transmit to the plotting room the required data.

NOTE.—In stations equipped with a depression position finder, he should place that instrument in adjustment for reading both ranges and azimuths regardless of whether tracking is to be by vertical base or by horizontal base. This will insure readiness for a change of system if required.

b. Reader.—The reader functions under the direction of his observer. He assists in the care, adjustment, and orientation of the observation instrument and in the police of the station. Upon arrival at his station he performs such duties as are directed by the observer, tests the functioning of his communication with the plotting room, and reports to his observer. When the target has been assigned and tracking is started, the reader reads from the observation instrument at each time interval the azimuth, or the azimuth and the range, and transmits these data to the proper arm setter in the plotting room and records same.

■ 193. SPOTTING DETAILS.—*a. Observer.*—The observer is responsible for the care, adjustment, and use of his observation instrument, for the functioning of his detail, and for the police of his station. Upon arrival at his station he

makes an inspection of the station and equipment, tests the means of communication, orients and adjusts his instrument, and reports to the plotter, "S¹ (or S², etc.) in order." The detailed duties of the observer will depend upon whether observations of impacts are being reported as deviations from the target (or other point) or as azimuths. He identifies the target when assigned, reports to the battery commander, "S¹ (or S², etc.) on target", and thereafter follows the target with the vertical wire of his instrument. When the splash occurs, he accurately adjusts his instrument on the splash (that is, the splash pointer if reading deviations, or the vertical cross wire if azimuths are to be read), and either transmits the deviation thereof to the plotting room or halts his instrument long enough for the azimuth to be read and transmitted by his reader. If he is reporting deviations from the target and has no reader, he records his own data. In order to insure the identification of the splashes of the shots fired by his battery, the observer must be informed from the battery of the instant of firing and of the time of flight of the projectile or of the expiration of the time of flight.

b. Reader.—The reader functions under the direction of the observer. Upon arrival at his station he performs such duties as are directed by his observer, tests the functioning of his communication with the plotting room, and reports to his observers. When the target has been assigned, tracking started, and the impacts of shots occur, the reader reads, transmits to the proper spotting board assistant, and records the data determined from observation of the splashes.

■ 194. PLOTTING ROOM DETAIL—*a. Range officer.*—The range officer commands the battery range section and is responsible to the battery commander for the condition, adjustment, and use of the battery position finding equipment, for the training and efficiency of the battery range section, for the serviceability of the battery communication system, and for the police of the stations pertaining to the battery position finding system. When the battery is firing, his station is in the battery plotting room. At other times he may go wherever his presence is necessary in the performance of his duties. Before drill, practice, or action he makes a careful

examination of the plotting room equipment and apparatus. He verifies the adjustment of all position finding equipment and apparatus as often as may be necessary to insure their proper operation and their readiness for service at all times. He makes frequent inspections of all observation, spotting, and emergency stations. He receives the reports of the plotter and of the observers and reports to the battery commander, "Sir, stations in order," or reports such defects as he is unable to remedy without delay. During drill, practice, or action he maintains constant supervision over the functioning of the plotting room detail and, insofar as he is able to do so from his station in the plotting room, over the entire battery position finding service. He insures that such records are kept as are necessary to the analysis of the drill or target practice. He makes such changes in the assignment of position finding personnel to duties as are necessary to the efficiency of the battery as a whole. During firing he supervises the adjustment of fire in range and direction, making such decisions as may be necessary when questions arise.

b. Plotter.—The plotter is chief of the plotting room detail and as such is responsible to the range officer for the adjustment, condition, and serviceability of the plotting room apparatus; for the training and efficiency of the plotting room detail; and for the condition and police of the plotting room. He receives the reports from the observation stations, from the spotting stations, and from the various members of the plotting room detail; and reports to the range officer, "Sir, range section in order," or reports such defects as he is unable to remedy without delay. He is responsible for the orientation, adjustment, and use of the plotting board. During drill, practice, or action, the plotter plots on the plotting board the points representing the positions of the target at times of observation (plotted points) and determines the set-forward points. For a detailed description of his duties in plotting see chapter 10.

c. Platen operator.—The platen operator is necessary only when a plotting and relocating board is used. He assists the plotter in the orientation of the plotting board and

during plotting operates the platen in the manner set forth in paragraphs 75 to 77, inclusive.

d. Angular travel device operator or gun arm azimuth reader, No. 1.—(1) Where the Whistler-Hearn board is used for case II pointing No. 1 operates the tally dial and tally subdial of the plotting board. He keeps the tally dials properly set and calls out the angular travel of the target at the proper times.

(2) For case III pointing with the Whistler-Hearn board, No. 1 reads from the gun (or mortar) arm azimuth circle the uncorrected azimuth of the set-forward and predicted points.

(3) For case II pointing using the 110° board or a plotting and relocating board (Clove or M1), No. 1 operates the angular travel computer or other similar device. (See pars. 105 and 106.) Using the appropriate data determined on the plotting board, he determines from the angular travel device the reference number for use on the deflection board.

(4) For case III pointing with the Clove board or with the M1 board, No. 1 is eliminated.

e. Primary arm setter (plotting arm setter), No. 2.—(1) No. 2 is equipped with a telephone head set on the line from B¹ reader, and sets the B¹ arm of the plotting board at the azimuth received from the B¹ reader when the horizontal base or B¹ vertical base is being used. Prior to drill, practice, or action he receives and transmits to the plotter the report from the B¹ station. When B² vertical base is used, the B¹ arm setter's head set is in parallel with that of the B² arm setter, and he hears and repeats at the proper time the range as transmitted by the B² reader.

(2) Where the Clove board or the M1 board is used, No. 2 is the plotting arm setter. The plotter arm may be used to represent azimuths from either B¹ or B², depending on the orientation of the board. The plotting arm setter is equipped with a head set on the line from an observation station (B¹ or B²), and sets the plotting arm at the azimuth of the target as transmitted by the reader at this station. The duties of No. 2 are the same for horizontal, self-contained, and vertical base systems, except where the vertical base or a self-contained base station is at the directing point

of the battery, in which case the plotting arm of the plotting board is not used.

f. Secondary arm setter (relocating arm setter), No. 3.—(1)⁷ No. 3 is equipped with a telephone head set on the line to the B² station and, when horizontal or B² vertical base is used, sets the B² arm of the plotting board at the azimuth received from the B² reader. Prior to drill, practice, or action he receives and transmits to the plotter the report from the B² station. When B¹ vertical base is used, the B² arm setter's head set is parallel with that of the B¹ arm setter, and he hears and calls out at the proper time the range as transmitted by the B¹ reader.

(2) When the Cloke board or the M1 board is used, No. 3 is the relocating arm setter. The relocating arm may be used to represent the azimuth of either B¹ or B², depending on the orientation of the board. The relocating arm setter is equipped with a head set on the line to the observation station represented by the relocating arm, and sets the relocating arm at the azimuth of the target as transmitted by the reader at that station. Where vertical base is used from the directing point of the battery, the relocating arm will be used for plotting. In such a case, No. 3 receives the data for and sets the relocating arm as directed by the plotter in determining the range to the set-forward point, and reads and calls out at the proper time the azimuths of the predicted and the set-forward points.

g. Range correction board operator, No. 4.—No. 4 functions in the manner set forth in chapter 11 and transmits the ballistic range correction to No. 6. For details of his duties see paragraphs 86 to 89, inclusive. Except when the deflection board M1 is used, he operates the wind component indicator in the manner set forth in paragraphs 80 to 82, inclusive.

h. Set-forward device operator, No. 5.—No. 5 operates the set-forward ruler (or chart) and calls out to the plotter the travel to the set-forward point. This operator is not required when the set-forward scales are used by the plotter. His duties are the same for all systems of position finding.

i. Percentage corrector operator, No. 6.—No. 6 operates the percentage corrector in the manner set forth in paragraphs 91 and 92. He is equipped with a telephone head set on a line to the guns.

j. Deflection board operator, No. 7, and assistant operator, No. 8.—No. 7, assisted by No. 8 when necessary, operates the deflection board and transmits to the guns deflections for case II pointing and azimuths for case III pointing. See chapter 12 for methods of operation of deflection boards.

k. Fire adjustment board operator, No. 9.—No. 9 conducts the adjustment of fire in range by use of the fire adjustment board or of the bracketing adjustment chart in the manner set forth in paragraphs 136 to 139, inclusive, and 140 to 142, inclusive, respectively. This operator should be an officer, if one is available, otherwise an enlisted man familiar with the mechanics of adjustment of fire. In this latter case questionable points will be determined by the range officer.

l. Spotter, No. 10, and assistant spotters, Nos. 11 and 12.—No. 10, assisted by Nos. 11 and 12, by the use of the spotting board determine the range and direction deviations. See chapter 13 for methods of operation of spotting boards.

m. Data transmission device operator, No. 13.—When mechanical data transmission devices are used, No. 13 receives the corrected range or elevation and the deflection or corrected azimuth from the proper persons and sets them at the proper time on his device. For zone fire he also keeps the proper zone indicated. When the data transmission system M5 is used, four operators are required. (See par. 186.)

n. Recorders, Nos. 14 and 15.—These operators, if required, keep records necessary for analysis of drill and service practice.

NOTE.—For a rapid fire battery the fire control personnel perform their duties in a manner similar to that of corresponding personnel as described above with such modifications as the somewhat different equipment makes necessary.

SECTION III

OTHER BATTERY FIRE CONTROL PERSONNEL

■ 195. GENERAL.—Exclusive of the firing section of a battery, certain other individuals not a part of the range section are necessary to assist the battery commander in the conduct of fire. The number required will vary, depending on the

matériel manned. These men are members of the command detail of the battery headquarters except in a battery of tractor drawn artillery, in which they are members of the command post detail of the operations section. They are under the immediate command of the battery commander and function in the battery commander's station.

■ 196. PERSONNEL.—The detail ordinarily is composed of the following personnel:

- a. One or more observers.
- b. Two buglers.
- c. One or more telephone operators.

■ 197. DUTIES.—*a. For case II pointing.*—(1) Each observer performs such duties in connection with the observation of targets and splashes as may be prescribed by the battery commander. Each is responsible for the orientation, adjustment, care, and operation of his instrument.

(2) The buglers perform such duties as may be prescribed by the battery commander. They may be called on to sound bugle signals; to act as telephone operators, recorders, orderlies, or messengers; or to perform certain duties in connection with prediction tests as described in paragraph 205.

(3) Telephone operators transmit and if so ordered record all commands and messages to or from the station. They are responsible for the care and operation of their telephones. They may be required to show the clock time of messages sent and received.

b. For case III pointing.—(1) An observer performs the duties of the observer in the conduct of prediction tests as described in paragraph 205. Each observer performs such other duties in connection with the observation of targets and splashes as may be directed by the battery commander. Each is responsible for the orientation, adjustment, care, and operation of his instrument.

(2) The buglers perform their duties as indicated for case II pointing.

(3) The telephone operators perform their duties as indicated for case II pointing.

SECTION IV

TRAINING

■ 198. GENERAL.—*a.* The training of the fire control and position finding personnel of a battery must be thorough and painstaking. Each individual must be possessed of an intimate knowledge of the functions, care, and operation of the instrument or device operated by him, and must possess a satisfactory general knowledge of all other position finding devices and the systems of position finding used by the battery. Each must understand the relation that data determined by him on his own device bear to data determined by others on their devices. Each individual should be so trained and drilled as to be expert in the operation of his own device, proficient in the operation of at least one other, and have a knowledge of the operation of all.

b. In addition to the regularly assigned position finding personnel, substitutes for all positions must be trained in order to provide replacements for absentees or casualties, to the end that the continuous, efficient functioning of the position finding service will be insured. Under war conditions at least three men must be assigned to each observation or spotting station so that a continuous watch may be maintained. At least two of these men must be qualified observers so that a complete manning detail may be available at all times.

■ 199. PLOTTER.—The plotter will be trained thoroughly in the detailed functioning of all apparatus or devices employed in the battery position finding system, in all methods of position finding contemplated for the use of the battery, in the methods of pointing, in the keeping of records, and in the analysis of drill and target practice. He must be trained in estimating the probable movements of targets based upon observed positions, in the making of accurate predictions, and in the coordinated functioning of the position finding service and the firing battery.

■ 200. OBSERVERS (BASE END).—Observers must be selected for their special aptitude for such duty. A fundamental requirement is that of excellent vision. They should be trained

in the care, operation, and adjustment of all observation instruments employed by the battery, the training to be such as to insure their expertness in the use of the instrument or instruments to which they are regularly assigned; in the distinguishing characteristics, features, and formation of warships and of other naval craft; in the subdivisions of the battery's water area (field of fire); in the identification of all prominent features in the water areas, such as channels, buoys, lighthouses, and datum points; in the systems of position finding and the methods of fire used by the battery; in the commands employed in the indication and identification of targets; in the functioning of the battery communication system, including use of the telephone; and in the coordinated functioning of the position finding service and the firing battery.

■ 201. OBSERVERS (SPOTTING).—In addition to the training outlined above for base end observers, spotting observers will be trained in the various methods of adjustment employed by the battery; in distinguishing between the impacts of mortar projectiles and those of gun projectiles and between the impacts of projectiles of the primary armament and those of the secondary armament; in the location of the center of impact of a salvo; in the operation of the system of spotting; and in the operation of the spotting board used by the battery.

■ 202. READERS.—Readers must be trained in those subjects outlined for the training of observers. They must possess in only a slightly less degree the qualifications of their observers and be so trained as to function efficiently as a relief to the observer during long periods of observation. They must be trained in the proper and careful keeping of the records of data determined at their stations; in the essentials of the battery communication system; and in the care and use of the telephone and the transmission of orders, commands, and messages.

■ 203. OTHER PERSONNEL.—*a.* Each individual member of the plotting room detail must be trained in the systems of position finding employed by the battery: in the methods of pointing; in the detailed functioning, care, adjustment, and operation

of his device or apparatus under all conditions; in the general operation and use of all other plotting room devices; in the keeping of records; in the analysis of drill and target practice; in the use of telephones; and in the coordinated functioning of the position finding service and the firing battery.

b. Plotting room details must be trained in the accomplishment of rapid changes of orientation and in the alternative use of all base lines established for the battery. The training must be such that a change of orientation necessitated by a change of base lines may be made in the shortest possible time and with a minimum interruption of the processes of position finding. To this end, range officers will so organize the details and the mechanics of reorientation as to effect the necessary changes with a minimum effort, assigning to each member of the range section necessarily affected certain duties to be performed when commands are given necessitating changes of orientation, and so coordinating these duties as to insure expeditious accomplishment of results.

■ 204. USE OF HYPOTHETICAL COURSES.—Much of the training of a range section is conducted by assigning as targets for tracking commercial vessels in the field of fire. When these or other suitable targets are not available, recourse must be had to the use of hypothetical courses. Several of these courses should be on hand at all times. The data for them may be computed mathematically, may be determined graphically from the plotting board, or may be made up by recording readings actually taken on targets at some previous time. A computed course serves as a check on the accuracy of the operators of the plotting board as well as a check on the mechanical accuracy of the board. However, for training, courses prepared by determining the data graphically or courses for which the data are recorded from actual readings on targets previously tracked are satisfactory and are more easily prepared.

■ 205. PREDICTION TESTS.—a. In the calculation of case III firing data for rapidly moving targets, it is important that predictions in direction as well as in range be accurately made. Range predictions are checked by analysis of drill. Lateral predictions are checked by prediction tests. These

tests should be made frequently, during routine drills, to disclose any flaws in the plotter's procedure and to assist in the formulation of rules to be used by him in the location of the set-forward point.

b. The prediction testing detail should consist of an observer, a reader equipped with a stop watch that will run in synchronism with the TI signals, and an assistant supplied with a time of flight chart or scale.

c. The observer tracks the target with an accurately oriented azimuth instrument. The reader keeps his stop watch synchronized with the TI signals. The uncorrected range to the set-forward point whose azimuth is being checked is sent to the assistant who determines and calls off to the reader the time of flight. The reader notes the time of the firing signal and at the end of the time of flight calls HALT, whereupon the observer stops tracking long enough for the reader to read and record the azimuth.

d. This azimuth, corrected for the azimuth difference between the observation station and the directing point, should check with the uncorrected azimuth of the set-forward point as determined by the plotter. If there are appreciable discrepancies between these two azimuths, the work of the plotter should be checked to determine the cause of the errors so that corrective measures may be taken.

■ 206. POINTING TESTS.—a. The purpose of pointing tests is to make an over-all check of the orientation and functioning of the position finding system and the gun sights or the azimuth scales for case III pointing. This check, if made throughout the field of fire, will disclose the presence of any errors in orientation that may cause the guns to creep off the target laterally. Since these tests interfere with the regular functioning of the system, they cannot be conducted as a part of the drill, but they may be made as a final check-up during preparation for firing.

b. The detail should consist of an officer or a noncommissioned officer and the gun pointer or the azimuth setter.

c. The procedure in the plotting room is the same as for normal tracking except that the only data furnished to the guns are the azimuth of the predicted point. The gun pointer or the azimuth setter performs his normal duties.

The officer or noncommissioned officer sights through the bore of the gun on which muzzle threads have been placed, and checks the position of the target at the sounding of the firing signal or of the TI bell.

d. If the target is not consistently on or near the vertical thread at the sounding of the firing signal or the TI bell, the orientation and functioning of the system should be checked to locate the cause of the error.

CHAPTER 20

FUNCTIONING OF FIRE CONTROL AND POSITION FINDING SYSTEMS

	Paragraphs
SECTION I. General	207
II. Action before target is assigned.....	208
III. Action when target is assigned.....	209-211
IV. Functioning when using other equipment.....	212-215
V. Functioning of a spotting system.....	216

SECTION I

GENERAL

■ 207. GENERAL.—*a.* The equipment to be found in the plotting room of any one seacoast artillery battery will differ from that in almost any other battery. There are several reasons for this. The newly developed instruments are not furnished to all batteries, especially the older batteries. Again, the requirements of the different batteries are different depending on caliber and range. And finally, minor modifications are made in the systems to suit the preferences of the battery officers.

b. Obviously it would be impossible to describe the operation of all possible combinations of the numerous instruments and improvised instruments that are in use without burying the main idea in a mass of detail. It has been thought best to describe the operation of one system only, and to give in later paragraphs necessary notes on the variations of this system when other instruments are substituted. Only the more important cases of this kind are considered.

c. The system chosen is that shown in figure 92. It is for a battery of fixed guns of major caliber, and the plotting room is equipped with a 110° plotting board; range correction board M1; percentage corrector M1; deflection board M1; spotting board M2; and fire adjustment board M1. The base end observers and the spotting observers are equipped with azimuth instruments, M1910A1.

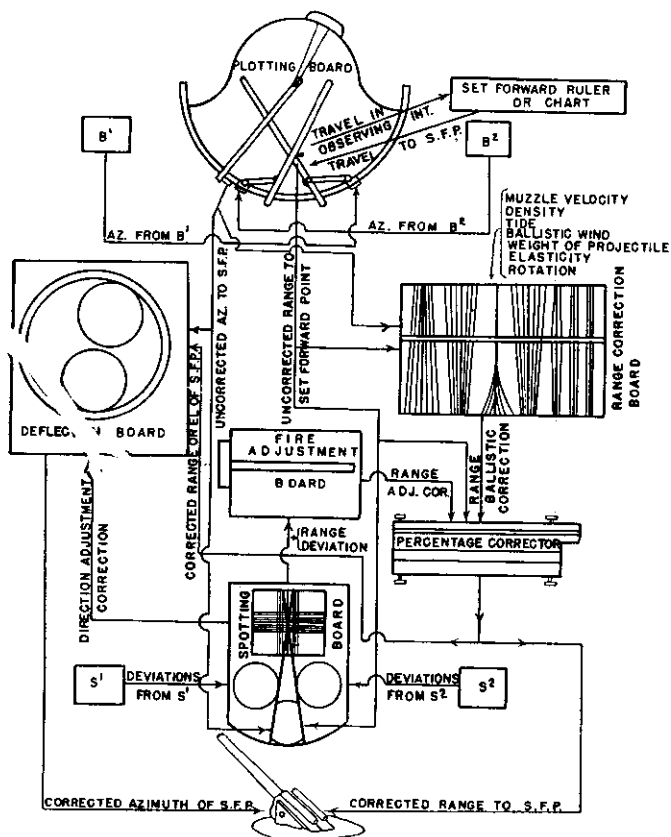

FIGURE 92.—Schematic diagram of routing of position finding and firing data.

SECTION II

ACTION BEFORE TARGET IS ASSIGNED

■ 208. PREPARATION FOR CALCULATION OF DATA.—*a.* Before the target is assigned, all preparations for the calculation of firing data must be made. The range officer, having maintained his

equipment in adjustment by frequent tests, makes a quick survey of the most important features.

b. All communication lines are tested by the men who operate them.

c. The meteorological message is received by the man designated for that duty and is recorded on a form drawn up by the range officer. Air temperature can be taken from the message at once, but the proper ballistic density and ballistic wind to use cannot be determined until the target is assigned and its range determined.

d. The tide message is received from the tide station and recorded.

e. All possible information as to weights of projectiles is received from the battery executive. By coordination within the battery, this information can be in the hands of the range officer well in advance of the time the projectiles will be used.

f. A record of all available information as to the action of the powder on hand in the battery is maintained by the range officer. This includes information as to its previous performance, reduced to standard temperature, together with powder tag markings, present temperature, and other information. The range officer will have determined beforehand the muzzle velocity to be assumed with any combination of ammunition likely to be used, and insofar as possible the battery commander will give both the range officer and the battery executive advance warning as to the combination that will be ordered.

SECTION III

ACTION WHEN TARGET IS ASSIGNED

■ 209. PRELIMINARY STEPS.—*a.* The assignment of the target to the battery by the group commander will be followed by its assignment to the various elements of the battery by the battery commander. This assignment will convey the battery commander's decision as to the ammunition, the observation and spotting stations, the case of pointing, and the method of tracking to be used.

b. The following steps are taken immediately by the plotting room detail:

(1) The plotting board is made ready for tracking, using the stations and method of tracking ordered.

(2) The required communication set-up is arranged by proper manipulation of the switchboxes.

(3) The spotting board is made ready for spotting, using the stations ordered.

(4) The operators of the range correction board, percentage corrector, and deflection board turn to the charts corresponding to the ammunition ordered.

(5) The operator of the range correction board makes notation as to the muzzle velocity, height of site (tide), weight of projectile, and temperature (elasticity) curves to be used.

c. The observers designated to track the target, and the gun pointers when case II pointing is ordered, identify the target and bring their instruments or guns to bear on it. Each then reports, "—— on target." As each reports on target, a battery officer commands TRACK, without waiting for others to get on.

d. The observers follow the target as prescribed in paragraph 192a. If vertical base tracking has been ordered, the observer tracks in azimuth as described, and in addition he tracks in range by keeping the horizontal wire of his instrument at the waterline of the target. At the third stroke of the bell, he holds both the azimuth reading and the range reading stationary long enough for the reader to transmit them to the plotting room.

■ 210. APPROXIMATE DATA.—a. As soon as the plotting room has received the first readings from the observation stations, the position of the target is plotted, and the plotter calls out, "Approximate data." He then reads off the range to the plotted point, and the operator of the gun arm reads off the azimuth to that point, both loud enough to be heard by all in the plotting room.

b. Using this approximate range, the ballistic wind zone is selected and the ballistic wind and ballistic density are taken from the meteorological message by the range officer. The ballistic density and rotation curves to be used on the range correction board are noted. The direction and speed of the ballistic wind are set on the deflection board.

c. The deflection board operator turns the deflection board to the approximate azimuth. This determines the range and lateral components of the ballistic wind for use on the range correction board and on the chart of the deflection board itself. The chart is turned to the approximate range, the pointer is brought to the curve corresponding to the lateral wind component, and a first (approximate) reading sent to the guns (in case III pointing) so that they may be traversed to the target.

d. The range correction board operator turns his chart to the approximate range, takes the range component of the ballistic wind from the deflection board, and determines an approximate ballistic correction. This he transmits to the operator of the percentage corrector.

e. The percentage corrector operator turns his range scale to the approximate range and transmits the range to the guns except when ranges are set on the guns in angular units (as elevations), in which case he reads off an approximate elevation which he sends to the guns. After receiving the ballistic correction he sends to the guns a second approximate range (or elevation) if it differs materially from the first.

f. The spotting board is set to the approximate range and azimuth.

■ 211. CORRECTED DATA.—a. After the course of the plotted points has steadied so that prediction is possible, the plotter makes a prediction as described in paragraph 69. The range and the azimuth of the set-forward point are called out for all to hear. All other data are transmitted in tones as low as reliable transmission will permit. The outstanding characteristic of a well-trained range section is that it is quiet.

b. The percentage corrector operator sets the range to the set-forward point on his board, uses the ballistic correction already set, and if necessary converts this range into elevation. He transmits the firing range or the firing elevation to the guns immediately or holds it for transmission on signal, according to the method in use in that particular battery.

c. The deflection board operator sets the range and the azimuth of the set-forward point on his board, using the lateral

component of the ballistic wind that shows on the wind component indicator after the azimuth is set. If pointing is by case III, the corrected azimuth is read from the board by the assistant operator. If pointing is by case II, travel is computed by a device built into the board. This device is operated by the assistant who computes the deflection and transmits it immediately to the guns. (See par. 109.)

d. The range correction board operator sets the range to the set-forward point on his board, follows the curves, and gives a new ballistic correction to the percentage corrector operator when it changes by $\frac{1}{16}$ of 1 percent.

SECTION IV

FUNCTIONING WHEN USING OTHER EQUIPMENT

■ 212. PREDICTION SCALE.—When the prediction scale is used, a set-forward rule or set-forward chart is required to give the plotter the travel during the dead time plus time of flight. In this case the operation is performed by the set-forward device operator. The set-forward rule or chart should be graduated in terms of elevation or range as this is sent to the guns, so that it will not be necessary to put time of flight graduations on the percentage corrector strip and have the percentage corrector operator make an extra reading of time of flight. The ruler or chart operator will simply set what is sent to the guns.

■ 213. OTHER PLOTTING BOARDS.—a. *Plotting and relocating board M1.*—When this board is used an additional operator, called the platen operator, is needed. (See par. 77.)

b. *Plotting and relocating board, M1923 (Clove).*—There is no essential difference between the operation of the plotting and relocating board M1 and that of the M1923 (Clove).

c. *Whistler-Hearn plotting board.*—The essential features in which the Whistler-Hearn plotting board differs in operation from the other plotting boards are that it has a built-in device for computing angular travel, and the azimuth of the set-forward point is read on the gun (or mortar) arm azimuth circle.

■ 214. ANGULAR TRAVEL COMPUTOR.—No deflection board other than the M1 computes its own angular travel. When any deflection board other than the M1 is used with a plotting board other than the Whistler-Hearn, it is necessary in computing deflections for case II pointing to use some device, usually improvised, to compute the angular travel. No. 1 performs this operation.

■ 215. WIND COMPONENT INDICATOR.—The wind component indicator is used when the battery is not equipped with the deflection board M1. It is operated by the range correction board operator.

SECTION V

FUNCTIONING OF SPOTTING SYSTEM

■ 216. METHOD OF OPERATION.—*a.* Each spotting observer tracks the target, keeping the vertical wire of his instrument on the observing point. When the splash occurs, tracking is stopped immediately, and the angular deviation of the splash is then read from the deflection scale in the instrument and is transmitted to the spotting board. (See par. 115.) Axial observers observe on the center of the splash; flank observers observe on the edge of the splash nearest the battery.

b. To assist the spotting observers in identifying the splash, a stop watch kept at the spotting board is started when the shot is fired and, when the time of flight has elapsed, the warning "Splash" is called out to the observers.

c. The angular deviations observed by the spotting observers are set into the spotting board. Range deviations in percentage are read off the spotting board and transmitted to the range adjustment board operator. If lateral adjustment of fire is being conducted either by use of a separate observer stationed at or near the directing point or by the method of jumping splashes (see par. 117), lateral deviations need not be read from the spotting board unless desired as a check on the lateral deviations determined by other means. If lateral deviations determined on the spotting board are to be used as the basis for the lateral adjustment of fire, they are read in angular units and are transmitted to the person designated to make the adjustment. Lateral adjustment

corrections may be determined graphically on an improvised board similar to the fire adjustment board used for range adjustment, or they may be determined by simple paper and pencil computations.

d. Range adjustment corrections are set usually on the percentage corrector, but there may be cases when they are set on the range correction board.

APPENDIX I
GLOSSARY

NOTE.—Definitions of other terms used in coast artillery will be found in FM 4-155.

Adjustment of fire.—The process of determining and applying corrections to the firing data to bring the center of impact to the adjusting point and to keep it there.

Aerial observation.—Observation of fire from aircraft.

Aiming point.—The point on which the gun pointer sights when pointing the gun.

Altitude.—The vertical distance above or below a specified datum level, usually sea level at mean low water. It is sometimes called height of site.

Angle of departure.—The angle between the line from the gun to the target and the axis of the bore when the projectile leaves the muzzle.

Angle of elevation.—The angle between the line from the gun to the target and the axis of the bore when the piece is pointed in elevation.

Angle of jump.—The difference between the angle of departure and the angle of elevation. Its component in the vertical plane is called the vertical jump and its component in the horizontal plane is called the lateral jump.

Axial observation.—Observation of fire from a point on or near the battery-target line. An axial station is one from which the angle battery-target station is less than 100 mils.

Axis of the bore.—The center line of the bore of the cannon.

Axis of trunnions.—The axis about which a cannon is rotated in elevation.

Azimuth difference.—The difference, due to displacement, between the azimuths of a point as measured from two other points; or the angle subtended at the point in question by a line connecting the two other points. It is also called parallax.

Backlash.—The lost motion or play in a mechanical system.

Ballistic area.—The intervening space lying between the impacts of two consecutive salvos, one of which consists of all overs and the other of all shorts.

Ballistic course.—An assumed course which is a mean line drawn through two or more ballistic areas or points.

Ballistic point.—A point where a hit or a mixed salvo was obtained.

Base line.—A line of known length and direction between two observation stations or two spotting stations, the positions of which with respect to the battery are known.

Base ring.—The metal ring which is bolted to the concrete of the emplacement and which supports the weight of the cannon and carriage.

Battery manning table.—A table containing a list of names detailing the personnel of a battery to their posts.

Battle chart.—A chart used in a group or a higher command station, showing the water area covered by the armament of that command.

Bilateral observation.—Observation of fire from two observation stations.

Cant.—The angle made with the horizontal by the axis of the trunnions.

Center of dispersion.—See Dispersion.

Center of impact.—The point whose deviation is the mean of the deviations of the several shots of a series.

Conduct of fire.—The employment of technical means to place accurate fire on a target. Fire is usually conducted by the battery which is the normal fire unit.

Corrected azimuth.—The azimuth from the directing point to the target corrected for all known variations from those conditions assumed as standard in the construction of firing tables.

Corrected deflection.—The deflection corrected for all known variations from those conditions assumed as standard in the construction of firing tables.

Corrected elevation.—The firing table elevation corresponding to the corrected range.

Corrected range.—The range corrected for all known variations from those conditions assumed as standard in the construction of firing tables.

Data line.—A telephone line used for the transmission of data. (See Intelligence line.)

Datum level.—A spherical surface which represents mean sea level or other specified reference level from which altitudes are measured.

Datum point.—A fixed point, the azimuth and range of which have been determined from one or more observation stations or other positions.

Deflection.—The horizontal angle between the line of sight to the target and the axis of the bore when the piece is pointed in direction. It is usually expressed in reference numbers and is set on the sight. The deflection due to travel alone is called the uncorrected deflection.

Deviation.—The distance of a point of impact or center of impact from the center of the target. If a set of axes is drawn through the target, the *Y* axis being along the gun-target line and the *X* axis perpendicular to the *Y* axis, then the *Y* coordinate of the point of impact is called the longitudinal (or range) deviation and the *X* coordinate is called the lateral deviation. The shortest distance from the center of the target to the point of impact is called the absolute deviation.

Directing point.—The point in or near a battery from which the range and the azimuth to the target are determined in computing firing data. It is commonly referred to as the DP. It may be one of the guns or it may be a point centrally located with respect to the guns. In any case it is usually so far from either of the base end stations that data for either station would be appreciably different from data for the directing point. Therefore, relocation is necessary. A typical situation is shown in figure 3. If a gun of the battery is the directing point it is called the directing gun.

Dispersion.—The scattering of shots fired with the same data. The area over which the shots are scattered is called the zone of dispersion. The center of that area is called the center of dispersion.

Drift.—The divergence of a projectile, due to its rotation and the resistance of the air, from the vertical plane con-

taining the line of departure. It may be expressed in either linear or angular units.

NOTE.—The drift listed in firing tables includes lateral jump.

Elevation.—See Angle of elevation and Quadrant elevation.

Elevation difference.—The angular units of quadrant elevation corresponding to the gun difference for a particular range.

Elevation table.—A table of ranges with corresponding quadrant elevations, used in graduating, and in checking the graduations of, the range disk of a fixed cannon. The quadrant elevations listed are firing table elevations corrected for height of site.

Field of fire.—That portion of the terrain or water area covered by the fire of a gun or battery.

Fire control.—The exercise of fire direction and conduct of fire. Fire control equipment and installations are used both for the tactical direction of fire and for the technical conduct of fire.

Fire control installation.—The equipment which is employed in the fire control of any unit.

Fire direction.—The exercise of the tactical command of one or more units in the selection of objectives and in the concentration or distribution of fire thereon at the appropriate times.

Fire discipline.—The efficiency of the personnel in action which involves accuracy and alertness resulting from organization, drill, and coordinated effort.

Fire for effect.—Fire for effect is conducted at full rate of fire. Initially two-gun salvos are employed. By using the rules for adjustment of fire listed in paragraph 151, a course very close to the true ballistic course of the target is developed on the plotting board. After the ballistic course has been established through four ballistic areas or points, batteries equipped with more than two guns employ battery salvos. However, when more than two guns are being fired, no attempt is made to adjust the ballistic course. If at any time two consecutive salvos fall in the same sense, two-gun salvos are again employed in order to reestablish the ballistic course.

Firing azimuth.—The corrected azimuth further corrected

for an individual cannon. It includes individual corrections for displacement and for calibration.

Firing data.—A general term employed in speaking of the range (or elevation) and azimuth (or deflection), either corrected or uncorrected, that are used in pointing a cannon.

Firing elevation.—The firing table elevation corresponding to the firing range.

Firing range.—The corrected range further corrected for an individual cannon. It includes individual corrections for displacement, for lack of level of base ring, and for calibration.

Firing tables.—A collection of data, chiefly tabular, intended to furnish the ballistic information necessary for conducting the fire of a particular model of cannon with specified ammunition.

Fixed armament.—Seacoast artillery weapons that are placed in permanent firing positions.

Flank observation.—Observation of fire from a point on or near the flank. A flank station is one from which the angle battery-target-station is greater than 1,300 mils.

Gun difference.—The difference, due to displacement, between the range from a gun to the target and that from the directing point to the target.

Gun displacement.—The horizontal distance from the pintle center of the gun to the directing point or the directing gun of the battery.

Gun parallax.—The azimuth difference between the line from the directing point to the target and the lines from the gun to the target.

Gunnery.—The practice of firing guns. It includes a study of the flight of the projectile and of the technical considerations involved in the conduct of fire.

Height of site.—See Altitude.

High angle fire.—Fire delivered at elevations greater than the elevation corresponding to the maximum range.

Intelligence line.—A telephone line used for the transmission of orders and messages as distinguished from data. (See Data line.)

Jump.—See Angle of Jump.

Lateral deviation.—See Deviation.

Lateral jump.—See Angle of jump.

Longitudinal deviation.—See Deviation.

Low angle fire.—Fire delivered at angles of elevation at and below the elevation corresponding to the maximum range.

Maximum ordinate.—The difference in altitude between the gun and the highest point of the trajectory.

Meteorological datum plane.—The plane assumed as a basis or starting point for the data furnished to the artillery concerning atmospheric conditions. Its altitude is that of the meteorological station.

Mobile armament.—Seacoast artillery weapons that may be moved to and emplaced in temporary firing positions. This class consists of both railway and tractor drawn artillery.

Muzzle velocity.—The velocity of a projectile at the muzzle. It is also called the initial velocity.

Normal of a scale.—The reference number that represents zero units of the value concerned.

Observing point.—The point on which observers sight.

Orientation.—(1) The determination of the horizontal and vertical location of points and the establishment of orienting lines.

(2) The adjustment of the azimuth circle of a gun or of an instrument to read azimuths.

Orienting line.—A line of known direction over one point of which it is possible to place an angle measuring instrument.

Pintle center.—The vertical axis about which a gun and its carriage are traversed.

Point of impact.—The point where the projectile first strikes the ground or other material object.

Position finding.—The process of determining the range and direction of a target, or a predicted position of the target, from a battery.

Predicted point.—The point at which it is expected the target will arrive at the end of the dead time.

Predicting.—The process of determining the expected position of the target at some future time.

Predicting interval.—The interval between successive predictions of future positions of the target.

Primary armament.—Seacoast artillery weapons of 12-inch or greater caliber.

Probable error.—The error which is as likely as not to be exceeded. A value which will in the long run be exceeded half the time and not exceeded half the time.

Quadrant elevation.—The vertical angle between the horizontal and the axis of the bore when the gun is pointed in elevation.

Range.—The horizontal distance from the gun, observation station, or directing point of a battery to the target, splash, datum point, or other specified point.

Range deviation.—See Deviation.

Range difference.—The difference, due to displacement, between the ranges from any two points to a third point.

Ranging fire.—Fire to locate the target in a 500-yard ballistic area. Two-gun ranging salvos are employed. The first salvo is fired using data from the estimated course. Parallel courses are then assumed for subsequent salvos, changing the range by 1,000-yard increments, from the range to the current course in each case, until a change in sensings of impacts is obtained. Ranging fire is completed by firing a salvo in the center of the 1,000-yard bracket thus established, thereby locating the target within a 500-yard ballistic area or establishing a ballistic point.

Relocation.—The process of determining the range and the azimuth from one station to the target (or other point) when the range and the azimuth from another station to the target (or other point) are known.

Salvo.—One shot per gun, fired simultaneously or in a certain order with a specified time interval between rounds.

Seacoast artillery.—All artillery weapons used primarily for fire upon hostile naval vessels. It includes both fixed and mobile armament.

Searching up (down).—Arbitrarily increasing (decreasing) successive ranges to the assumed target location in order to bracket the target. The first two changes in range may be small. Thereafter the changes must be sufficiently large to insure bracketing the target regardless of its speed and direction. For general use with a 20-second predicting interval, searching is accomplished by: first, a 150-yard range change; next a change of 300 yards; and then a succession of changes of 600 yards each. Searching is employed only

during fire for effect using two-gun salvos at full rate of fire.

Secondary armament.—Seacoast artillery weapons of less than 12-inch caliber.

Sense.—The direction of a point of impact (or center of impact of a salvo) with respect to the target, that is, over or short, right or left.

Set-forward point.—A point on the expected course of the target at which it is predicted the target will arrive at the end of the time of flight.

Sight.—A device by which the gun pointer gives the gun the proper direction for firing. It is sometimes called a telescope.

Spotting.—The process of determining deviations or sensings for use in adjustment of fire.

Subareas.—Subdivisions of the water area in the field of fire, used to assist in the indication, identification, and assignment of targets.

Time of flight.—The elapsed time from the instant a projectile leaves the muzzle to the instant of impact or to the instant of burst.

Trajectory.—The curve described by the center of gravity of the projectile in flight.

Uncorrected deflection.—The deflection due to travel of the target during the time of flight.

Unilateral observation.—Observation from a station so located that the angle battery-target-station is between 100 and 1,300 mils.

Vertical jump.—See Angle of jump.

Zone.—When used with reference to mortar fire or to fire from guns or howitzers using more than one size powder charge, it refers to the area in which projectiles will fall when one particular size powder charge is used and the elevation is varied from the minimum to the maximum.

Zone of dispersion.—See Dispersion.

APPENDIX II

CONSTRUCTION OF CHARTS AND SCALES FOR SEA-COAST ARTILLERY FIRE CONTROL INSTRUMENTS

■ 1. GENERAL.—Many of the present fire control instruments for seacoast artillery contain charts or scales for the graphical solution of the various problems that arise in position finding and in the determination of firing data. This appendix has been prepared in order that the construction of these charts and scales may be understood, and when necessary their accuracy may be verified or new charts or scales may be constructed.

■ 2. DEFINITION OF SCALE.—A graphical scale is a curve or axis on which is marked a series of graduations corresponding in sequence to a set of numbers. A uniform scale is one in which the distances between successive graduations are equal. A nonuniform scale is one in which these distances are not equal.

3. CONSTRUCTION OF UNIFORM SCALE.—Let AB , figure 93, be a straight line of indefinite length and let the point O represent the origin from which the construction of the scale will begin.

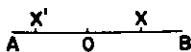

FIGURE 93.—Uniform scale.

Select a unit of length and assume that the lengths measured from O to the right are positive and those to the left negative. Then if $X=+3$, one may locate the point X on the scale AB by measuring 3 unit lengths to the right from O . Similarly, if $X'=-3$, then the point X' on the scale is found by measuring 3 unit lengths to the left from O .

The unit length should be selected of such a size that no two subdivisions of the scale are less than 0.04 inch apart, that is, there should never be more than 25 graduations to each inch of the scale in order that it may be used readily. In a great

many cases, it will be convenient to have fewer divisions per inch of the scale.

Example: Plot a uniform range scale at a scale of 500 yards to the inch. (See fig. 94.) Draw the straight line *AB*. Let the origin fall at *O*. This point should then be marked zero. One inch to the right of *O* according to our selected unit length will then represent a range of 500 yards and should be marked correspondingly. The divisions for 1,000, 1,500, 2,000, 2,500, and 3,000 yards should be placed at distances of 2, 3, 4, 5, and 6 inches from *O*, respectively. The intermediate graduations between the points 0 and 500 yards are located in the same manner; namely the division for 50 yards is 0.1 inch to the right of *O*, for 100 yards it is 0.2 inch, and so forth. No attempt should be made to construct this scale with graduations of less than 20 yards. Frequently more satisfactory results will be obtained by making the least graduation 50 yards.

Uniform scales frequently are constructed on the arcs of circles. Typical examples of these scales are the azimuth circles of guns, plotting boards, and azimuth instruments. The unit of measurement for the graduation of circular uniform scales may be a unit of length measured along the arc of the circle, but it is more frequently an angular unit. On the azimuth circle of a gun the unit of graduation and the unit of marking are the same, that is, 1° . On the ordinary clock dial the unit of graduation and the unit of marking are not the same. In this case 6° represent 1 minute of time.

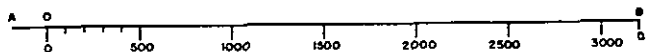

FIGURE 94.—Uniform range scale.

■ 4. NONUNIFORM SCALE.—In the example given in paragraph 3, the scale is marked in terms of the same unit with which it was graduated. It is often convenient to mark a scale in terms of some other unit which is a function of that used in constructing the scale. For example, in determining the angular travel to the set-forward point on the deflection board, M1905 (see par. 94, ch. 12), the rate of travel is multiplied by the time of flight by use of the range time scale. If that scale were marked in terms of time of flight it would be necessary

to determine the time of flight from the appropriate firing tables or an extract from those tables, using the range as an argument. Instead of this, the range time scale is marked in terms of ranges, and those markings are spaced according to the corresponding times of flight. The table following illustrates the problem. Column (1) contains the ranges; column (2) contains the corresponding times of flight as obtained from Firing Tables 8-A-2; and column (3) contains the scale distance in inches (to a scale of 1 inch=5 seconds time of flight) at which the ranges in column (1) should be marked on the range time scale. The scale marked in terms of time of flight would be a uniform scale whereas it becomes a nonuniform scale when marked in terms of range. The table contains partial data for marking range time scale on deflection board, M1905 (for 8-inch seacoast gun, M1888, 1888MI, and 1888MII, firing HE shell, Mk. I (Firing Tables 8-A-2).)

1	2	3
Range (yards)	Time of flight (seconds)	Scale distance (inches)
10,000	18.7	3.74
10,100	18.9	3.78
10,200	19.2	3.84
10,300	19.5	3.90
10,400	19.8	3.96
10,500	20.1	4.02

■ 5. LOGARITHMIC SCALE.—A logarithmic scale is an example of a nonuniform scale which is graduated in terms of the logarithm of the variable with which it is marked. Selecting an origin *O* on the straight line *AB* (fig. 95) and a unit of length, such as 1 inch equals 0.1000 logarithmic unit, a uniform scale of logarithms is constructed (upper scale of the figure) with the division marked 0.1000 at a distance

1 inch from the origin, the division marked 0.2000, 2 inches from the origin, and so forth. Using this uniform

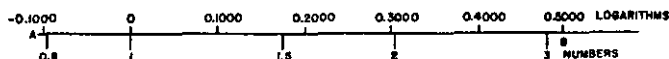

FIGURE 95.—Nonuniform scale.

scale, we may superimpose on it a scale graduated according to the antilogarithms, that is, according to the numbers instead of according to the corresponding logarithms. From a log table we may determine that the logarithm of the numbers 1, 2, and 3 are respectively 0.0000, 0.3010, and 0.4771. The division marked 1 should therefore be placed under the origin of the logarithm scale, the division 2 at a distance of 3.01 inches to the right of the origin, the division 3 at a distance of 4.771 inches to the right of the origin, and so forth. The logarithm of the number 0.8 is 9.9031-10 or -0.0969. The division marked 0.8 should therefore be placed 0.969 inch to the left of the origin as shown in the figure. The subdivisions between these main graduations may now be added. For example, the division for the number 1.5, whose logarithm is 0.1761, will be placed 1.761 inches from the origin. Such a logarithmic scale is obviously a nonuniform scale. This type of scale is frequently encountered in fire control equipment, since by graphical addition of the logarithms of any two quantities shown on such scales their product is obtained. The scales of an ordinary slide rule are of this type. Other typical nonuniform scales are range elevation scales constructed on a uniform scale of ranges but with elevations shown for the corresponding ranges.

Like the uniform scales, nonuniform scales may equally well be constructed on straight lines or on arcs. Examples of nonuniform scales on arcs are the scales of circular slide rules and scales of range disks whose graduations are on the periphery. In the latter case the ranges are marked on the range disks in place of the corresponding quadrant elevations at which the piece is pointed. The range disk thus acts as a range-elevation relation scale.

■ 6. DEFINITION OF CHART.—The term "chart" as used in this manual signifies a drawing or diagram by means of which

graphical solutions are made. A chart differs from the scales previously described in that the latter have only one dimension, namely, length, while charts have two dimensions, length and breadth. From a scale we may determine a quantity which depends upon one variable only, while from a chart we may determine quantities which depend on two separate variables. For example, from a range elevation scale we may determine the elevation corresponding to any selected range, but from the chart of a range correction board we may determine the different range corrections required for differing muzzle velocities at any selected range.

■ 7. RECTANGULAR COORDINATES.—In figure 96, let XX' be a horizontal straight line and let YY' be a straight line perpendicular to XX' at the point O . Any point in the plane of these lines is determined by its distance and direction from each of the two perpendiculars XX' and YY' . The distance from any point P to YY' is measured parallel to XX' and is called the "abscissa" of the point P . Similarly the distance from P to XX' is measured parallel to YY' and is called the "ordinate" of the point P . Together the abscissa and ordinate of P determine its location and they are called "coordi-

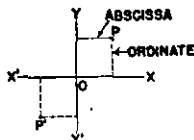

FIGURE 96.—Rectangular coordinates.

nates" of that point. The point O is called the "origin." All points to the right of O have positive abscissas and all points to the left have negative abscissas. All points above O have positive ordinates and those below have negative ordinates. Thus the points P and P' have the same values for their abscissas and ordinates, but the coordinates of P are both positive while those of P' are both negative. It is evident that if the location of a point is known, the coordinates of that point may be found by measurement; and if the coordinates are known, the point may be readily plotted.

■ 8. CONSTRUCTION OF CHART USING RECTANGULAR COORDINATES.—If it is desired to construct a chart from which we may determine graphically the effect in range due to changes in muzzle velocity for a certain gun, projectile, and powder charge, such a chart would in effect be a section of a range correction board chart. The appropriate firing tables contain the following data:

EFFECT IN YARDS OF RANGE DUE TO INCREASE IN MUZZLE VELOCITY

Range (yards)	Increase in muzzle velocity (feet per second)			
	20	40	60	80
	Effects in yards of range			
2,000.....	33	66	98	132
4,000.....	65	130	191	259
6,000.....	96	191	287	383
8,000.....	125	250	374	500
10,000.....	152	303	455	607

Figure 97 shows one solution of the problem of representing graphically the data listed in the foregoing table. The range effects have been plotted as abscissas and the ranges as ordinates. The unit of measure chosen for the abscissa scale (X axis) is 1 inch equals 100 yards. The ordinate scale (Y axis) is chosen as 1 inch equals 2,000 yards. Each curve showing the range effects at varying ranges for a selected increase in muzzle velocity is plotted in turn. For example, in plotting the curve for an increase in muzzle velocity of 20 foot-seconds, the first point is plotted with an abscissa (range effect) of 0.33 inch (33 yards) and an ordinate of 1 inch (2,000 yards); the next point is plotted with an abscissa of 0.65 inch (65 yards) and an ordinate of 2 inches (4,000 yards). When all the points of this curve have been plotted, it will be found that they do not lie along a straight line, but when connected they form a curve which is slightly concave toward the Y axis. In such a case, when connecting the points by a single line, the curve should be made smooth

and should be drawn as nearly as possible through all points. It is therefore the best representative line of quantities being plotted, and any single point lying at a distance on either side of the line will usually be the result of an error in plotting or an error in the data used in plotting. A glance at the completed chart shows the ease and rapidity with which the range effect for any change in muzzle velocity at any range may be determined graphically. For example, 20 foot-seconds' change in muzzle velocity at 9,000 yards will result in a range change of 140 yards; by interpolation between curves, 30 foot-seconds' change in muzzle velocity at 8,400 yards will result in a range change of 197 yards, and so forth.

Other solutions of this problem may be obtained by using different units of measure in the abscissa and ordinate scales or by plotting different values as abscissa and ordinate. For example, we might plot the changes in muzzle velocity as abscissas, the various ranges as ordinates, and obtain points

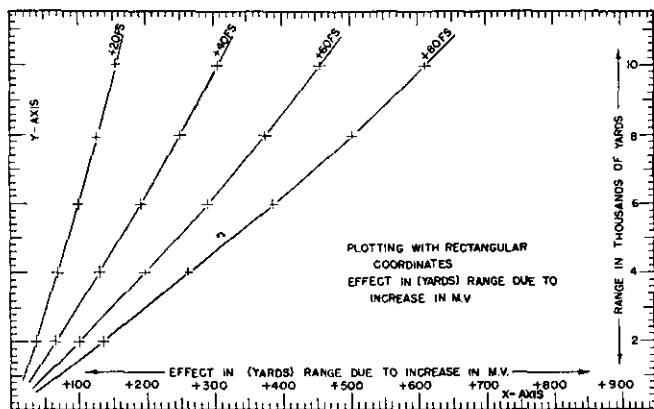

FIGURE 97.—Section of muzzle velocity effect curves with like rectangular coordinates.

from which curves of equal effects on the range might be plotted. Figure 98 illustrates a chart plotted in this way. The points listed in the table are first plotted with change

in muzzle velocity as abscissas and range as ordinates. Then by interpolation, the several points of equal range effect may be obtained. These points are then connected by smooth curves as shown in the figure. By interpolation between these curves, we may obtain the range effects for changes in muzzle velocity under any selected conditions. For example, at 4,600 yards the effect of an increase in muzzle velocity of 15 foot-seconds is found to be approximately 55 yards. The same result may be obtained from figure 97.

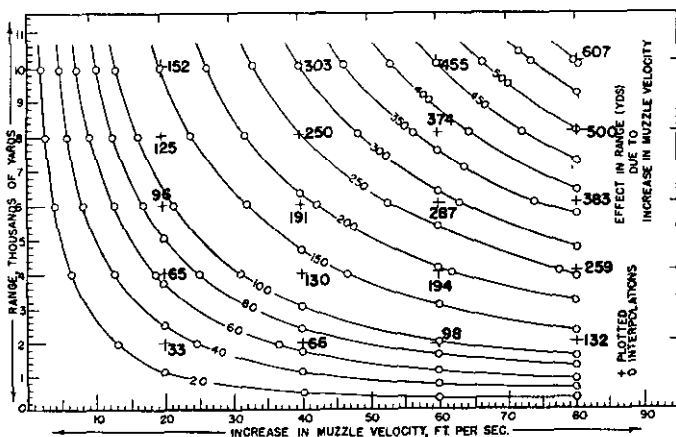

FIGURE 98.—Section of muzzle velocity effect curves with unlike rectangular coordinates.

From the foregoing discussion it is evident that there are several possible solutions for each problem in plotting. The following points should be considered before commencing to plot:

- The accuracy required in the solutions to be obtained from the chart.
- The limiting (usually the maximum) size of the chart.
- The range of values which must be plotted.

With *a*, *b*, and *c* in mind the size of the scales used for abscissas and ordinates may be selected. When choosing these scales, it is permissible and usually desirable to have the scale of abscissas different from the scale of ordinates.

■ 9. POLAR COORDINATES (fig. 99).—Given any fixed point O , called the "pole," and any fixed line OA , passing through O and called the "polar axis," the location of any point P with respect to O may be determined by its distance from O —that is, OP —and by the size of the angle AOP made by the intersection of the line OP with the polar axis OA . The distance OP is commonly called the "radius vector," and the angle AOP is called the "vectorial angle." Together, these quantities—an angle and a distance—are called the "polar coordinates" of the selected point. The vectorial angle is usually considered positive or negative as in trigonometry, that is, positive when measured counterclockwise from the polar axis, though this convention is by no means invariable. The radius vector is positive if the point P lies on the terminal line of the vectorial angle, that is, OP is positive if P lies anywhere

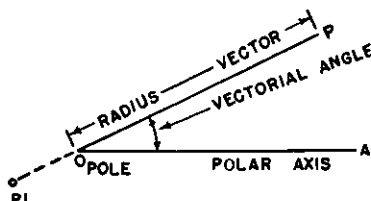

FIGURE 99.—Polar coordinates.

on the line OP to which the vectorial angle is measured. The polar coordinates of the point P' in figure 99 therefore may be given in two ways: first, with vectorial angle AOP' and radius vector OP' (a negative quantity); and, second, with vectorial angle AOP' and radius vector OP' (in this case a positive quantity). It is evident that every pair of numbers representing, respectively, a radius and a vectorial angle determines a single point. This point may be plotted as follows:

a. Construct the terminal line of the vectorial angle as in trigonometry, by laying off with a protractor the vectorial angle with zero of the protractor held on the polar axis and the center of the protractor at the pole.

b. Lay off the radius vector along this terminal line, taking into consideration the sign of the radius vector.

Polar coordinates and their use are well illustrated by considering the use of any standard plotting board. After

the set-forward point has been located, the data pertaining to it are transmitted to other instruments for conversion into firing data. The data determining each set-forward point, namely its range and azimuth from the directing point of the battery, constitute the polar coordinates of that set-forward point. The pole in this case is the directing point. The polar axis is the line of zero azimuth through this directing point. The radius vector is the range in yards from the directing point to the set-forward point, and the vectorial angle is the azimuth of the set-forward point measured from the directing point.

■ 10. CONSTRUCTION OF CHART USING POLAR COORDINATES.—Every plot of the course of a target that is made on a plotting board when the vertical base system of range finding is used illustrates chart construction with polar coordinates. The pole is the station of the depression position finder. The polar axis is the line of zero azimuth from this station. The radius vectors of the several plotted points along the course are the measured ranges to the target, and the vectorial angles are the corresponding target azimuths. In the determination of wind velocities for the preparation of meteorological messages, the horizontal projection of the balloon's path is plotted by polar coordinates. In this case the pole is the position of the theodolite and the polar axis is the line of zero azimuth through this position. The vectorial angles of the several points along the plotted path are the azimuths of the balloon at the times of observation. The radius vectors are the horizontal ranges to each of these positions. To illustrate plotting by polar coordinates, figure 100 shows a horizontal projection of the path of a balloon based on the data in the following table:

RECORD OF BALLOON SOUNDING

Minutes after release...	1	2	2¼	4½	7	9½	14½	
Azimuth, degrees.....	45	63	63	79	99	113	130	Vectorial angles.
Horizontal range, yards.	360	740	860	1,950	3,210	4,500	7,070	Radius vectors.

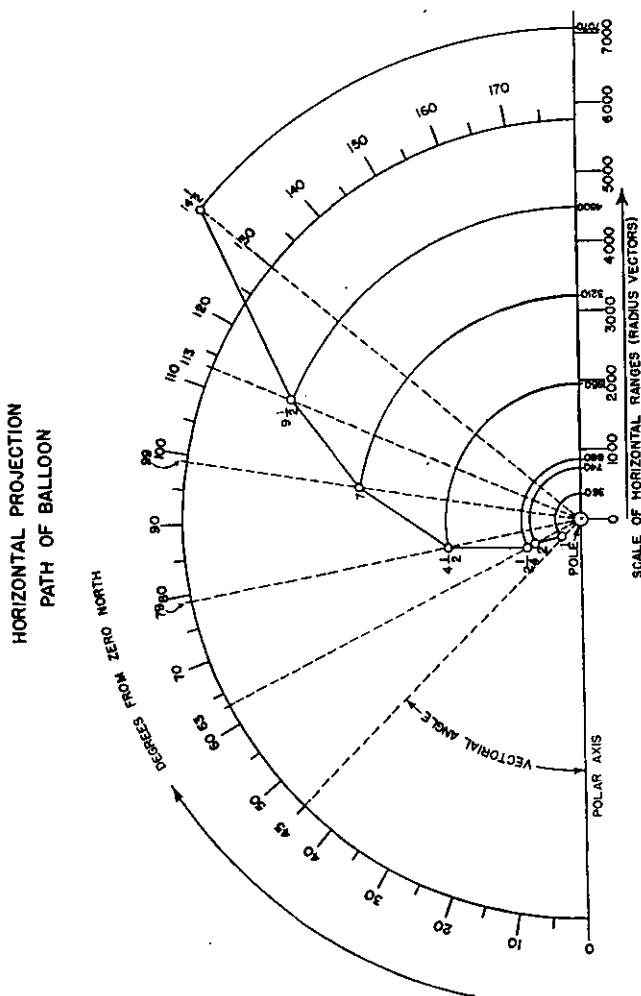

FIGURE 100.—Horizontal projection of path of balloon, polar coordinates.

To plot the point for 1 minute, draw the radius from the pole to the division of the azimuth circle marked 45° (thus laying off the vectorial angle). Along this line, measure out from the pole a distance equal to 360 yards (the radius vector) on the scale of horizontal ranges. This point is marked 1 in the figure. The location of the remainder of the points along the plotted path is indicated in the figure.

■ 11. NONUNIFORM SCALES IN CHART CONSTRUCTION.—Up to this point, all charts discussed were constructed with uniform scales. Frequently it is advisable to use charts constructed with nonuniform scales. A chart plotted with rectangular coordinates may have its abscissa scale uniform and its ordinate scale nonuniform, or vice versa, or both scales may be nonuniform. Similarly, the scale of radius vectors of a chart plotted with polar coordinates may be nonuniform, while the scale of the quantity expressed in terms of the vectorial angles may be uniform. Figure 101 illustrates a piece of logarithmic cross section paper used for plotting when both abscissa and ordinate scales are to be nonuniform and logarithmic. Other cases of the use of nonuniform scales in plotting charts will be illustrated in the subsequent discussion of specific charts used in fire-control equipment.

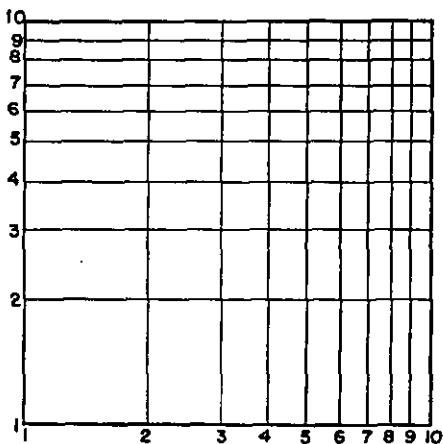

FIGURE 101.—Logarithmic cross section paper.

■ 12. RANGE-ELEVATION RELATION SCALE FOR PERCENTAGE CORRECTOR M1.—The purpose of a range-elevation relation scale used on a percentage corrector is twofold. It must provide means not only for converting ranges into elevations for use in pointing a gun but also for applying percentage corrections to the ranges before conversion. Therefore the range scale, which is the basic scale in this case, must be logarithmic. The elevation scale, which is the secondary scale in this case, consists of markings in terms of elevations placed opposite the corresponding ranges. The scales are placed on a removable strip of cloth-backed tape in order that the percentage corrector may be used with other types of armament. Since this tape is liable to change shape in handling and under varying atmospheric conditions it is well to verify its condition before use.

Suppose that it is desired to construct a section of the range-elevation relation scales for a 155-mm gun firing with normal charge and HE Shell, Mk. III with Mk. IV-star fuze between the ranges of 13,500 and 14,600 yards, using a scale of 1 log unit=200 inches. The data contained in columns (1) and (2) of the following table may be extracted from the appropriate firing tables (155-B-4, part 2b-1).

COMPUTATION OF DATA FOR RANGE-ELEVATION SCALE, 155-MM GUN

1	2	3	4	5
Range (yards)	Elevation (mils)	Log range	Log range --log 13,500	Scale distance (inches)
13,500	492.4	4.13033	0.00000	0
13,600	500.2	4.13354	.00321	.64
13,700	508.2	4.13672	.00639	1.28
13,800	516.4	4.13988	.00955	1.91
13,900	525.0	4.14301	.01268	2.54
14,000	533.8	4.14613	.01580	3.16
14,100	542.8	4.14922	.01889	3.78
14,200	552.0	4.15229	.02196	4.39
14,300	561.4	4.15534	.02501	5.00
14,400	571.0	4.15836	.02803	5.61
14,500	580.8	4.16137	.03104	6.21
14,600	590.8	4.16435	.03402	6.80

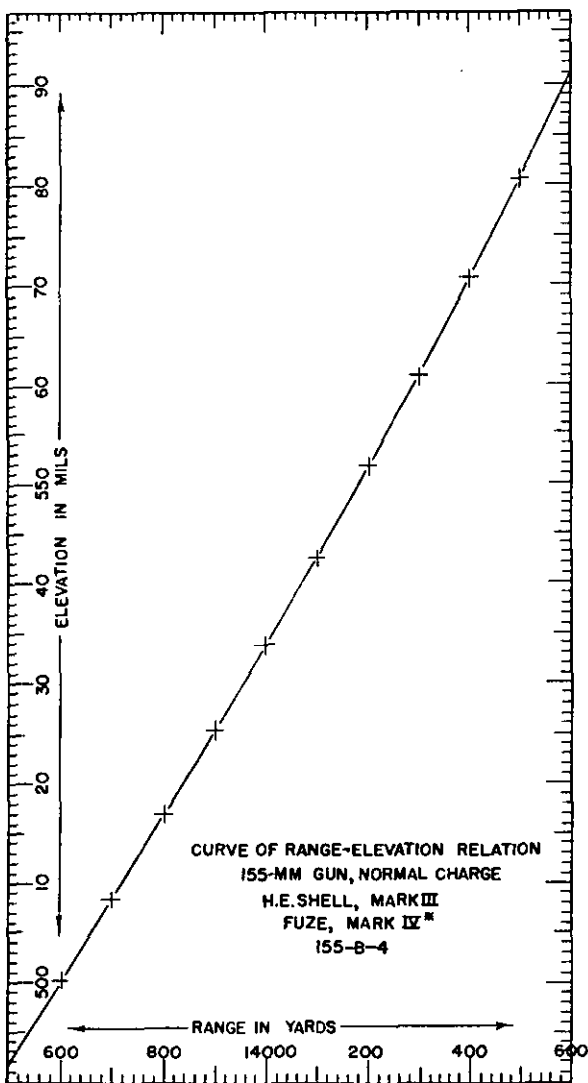

FIGURE 102.—Curve of range-elevation relation, 155-mm gun.

The 100-yard graduations of the range scale are plotted by measuring from any selected point marked 13,500 the distances tabulated in column (5). The graduations for each 20 yards of range may be plotted by straight interpolation between each 100-yard mark with sufficient accuracy for practical purposes.

The 5-mil markings for the elevation scale must now be fitted onto the scale in their proper relation by interpolation between columns (1) and (2).

A graphical method of interpolation, being faster than the mathematical method, will be illustrated. From the range-elevation relation shown in columns (1) and (2) a curve may be plotted, as shown in figure 102, using ranges as abscissas and elevations as ordinates. Ranges should be shown to the nearest 10 yards and elevations to the nearest 0.1 mil but, due to lack of space, are less exact in the figure. From such a curve, the range corresponding to any desired elevation may be read and the elevation marking placed opposite that range on the scale. For example, the elevation marking for 510 mils should be placed opposite the range of 13,720 yards and that for 560 mils, opposite the range of 14,285 yards. Figure 102 could be used for the location of all points on the elevation scale but such accuracy is unnecessary. After the markings for each multiple of 5 mils have been located those for the intervening mils, to the nearest mil, may be put in by straight interpolation between the 5-mil marks.

When more than one type of projectile or powder charge may be used, one or more additional elevation scales may be constructed, using the same basic range scale. The range elevation tape for a 155-mm gun, for instance, has an elevation scale for use when firing with the normal charge and another for use when firing with the supercharge.

■ 13. RANGE-RANGE RELATION SCALE FOR PERCENTAGE CORRECTOR M1 (fig. 103).—The range disks with which fixed sea-coast guns are equipped are graduated for a particular combination of powder charge and projectile and for a particular height of site. Some of these batteries are provided with range disks constructed for each combination of projectile and powder charge used by the battery. For those guns pro-

vided with only one range disk, the problem of determining the correct range settings for a combination of projectile and powder charge different from that for which the range disk is graduated is solved by the use of range-range relation scales on the percentage corrector. An example will perhaps best illustrate the problem. Assume that a battery of 12-inch sea-coast guns mounted on barbette carriages 100 feet above sea level is furnished with 870-pound A. P. projectiles (Firing Tables 12-L-4) and 975-pound A. P. projectiles (Firing Tables 12-F-3), but is equipped with range disks for the 870-pound projectiles only. If the target is at 10,000 yards, using the 870-pound projectiles the height of site correction is 241 yards, and the 10,000 division will be found placed on the range scale so as to give the gun an elevation of 107.8 mils, corresponding to a map range of 9,759 (10,000-241) yards. For the 975-pound projectiles, reference to the firing tables shows that the height of site correction is 236 yards and that the elevation corresponding to 9,764 (10,000-236) yards is 114.5 mils. Therefore, if when firing the 975-pound projectiles at 10,000 yards the guns were laid to the 10,000-yard division of the range scale, they would be laid at an elevation of 107.8 mils instead of the 114.5 mils required, and the shots would fall short of the target. A range-range relation scale is therefore required for this battery, and it will give the proper range settings to be used when firing the 975-pound projectiles.

The range-range relation scale consists of two range scales so arranged as to give these results for all ranges. One range scale may be considered as the range-to-target scale. It is an ordinary range scale constructed logarithmically (as described for the basic range scale, par. 12) in order that ballistic and adjustment corrections may be applied as percentages. The other scale contains the ranges at which the range disks for the 870-pound projectiles must be set in order to attain with the 975-pound projectiles the ranges given on the first scale; it is not a logarithmic scale, since the divisions are not located according to that law, and percentage corrections must be applied to the first scale before conversion.

The first step in the construction of the second scale (the range-range relation scale) is the computation from the fir-

ing tables of the relationship existing between the ranges corrected for height of site for the two combinations of projectile and powder charge. This process is illustrated in the following table:

COMPUTATION OF RANGE-RANGE RELATION SCALE

(12-inch seacoast gun, M1895, on 12-inch barbette carriage, M1917; height of site, 100 feet; range disks graduated for 870-pound A. P. projectile (Firing Tables 12-L-4); nonstandard ammunition, 975-pound A. P. projectile (Firing Tables 12-F-3))

Nonstandard ammunition				Standard ammunition			Non-standard ammunition
1	2	3	4	5	6	7	8
Map range (yards)	Correction for height of site (yards)	Corrected range (yards)	Corresponding elevation (mils)	Correction for height of site (yards)	Corrected range (yards)	Corresponding elevation (mils)	Ranges that will be attained for elevations in column 7 (yards)
9,000.....	274	8,726	100.0	283	8,717	93.6	-----
9,500.....	254	9,246	107.2	261	9,239	100.7	9,050
10,000.....	236	9,764	114.5	241	9,759	107.8	9,540
10,500.....	220	10,280	122.1	223	10,277	115.2	10,045
11,000.....	205	10,795	129.7	207	10,793	122.7	10,540
11,500.....	192	11,308	137.5	192	11,308	130.5	11,050
12,000.....	179	11,821	145.5	179	11,821	138.5	11,560
Source....	Part 2, table B, F. T. 12-F-3.	Column 1 minus column 2.	Part 2, table A, F. T. 12-F-3.	Part 2, table B, F. T. 12-L-4.	Column 1 minus column 6.	Part 2, table A, F. T. 12-L-4.	Interpolation between columns 1 and 4.

NOTE.—Firing tables show elevations in degrees and minutes as well as in mils and tenths of mils. Computation in mils and tenths of mils is preferable.

For convenience, the ammunition for which the range drum is graduated is hereafter called the "standard ammunition," while the other combination of projectile and powder charge is called "nonstandard ammunition." The proper firing tables give the height of site corrections for both types of ammunition for the several map ranges given in column 1. These values are listed in columns 2 and 5 of the tabulation. Columns 3 and 6 show the ranges corrected by the amount of these height of site corrections, and columns 4 and 7 are the corresponding corrected elevations. Columns 1 and 7 show the relationship between map range and corrected elevation for the standard ammunition for which the range drums are graduated. The next step is to determine the range that would be given by the nonstandard ammunition for each of the elevations shown in column 7. These data are obtained by interpolation between columns 1 and 4. For example the range that would be given by the nonstandard ammunition for an elevation of 100.7 mils is

$$9,000 + \frac{100.7 - 100.0}{107.2 - 100.0} \times 500 = 9,050$$

(A comptometer will facilitate making these interpolations.) Thus, if, using the nonstandard ammunition, ranges are set according to the values listed in column 1, the elevations set will be those in column 7 and the ranges attained will be those listed in column 8. There are now sufficient data to proceed with the plotting of the range-range relation scale.

A section of the completed scale is shown in figure 103. The scale on the right is the logarithmic range scale, constructed as explained in paragraph 12; that on the left is made up as follows: Opposite the divisions of the logarithmic range scale representing the ranges shown in column 8 of the tabulation, place the divisions of the range-range relation scale representing the ranges shown in column 1. For example, place the 9,500-yard division of the range-range relation scale opposite the 9,050-yard division of the logarithmic range scale; and the 10,000-yard division of the range-range rela-

tion scale opposite the 9,540-yard division of the logarithmic range scale. A convenient means of plotting the intermediate graduations of the range-range relation scale is by use of a log scale that already has been constructed. Move the log scale along the range-range relation scale until the proper number of graduations are intercepted and plot the graduations accordingly. For instance, between the 9,500-yard graduation and the 10,000-yard graduation there should be twenty-four 20-yard graduations.

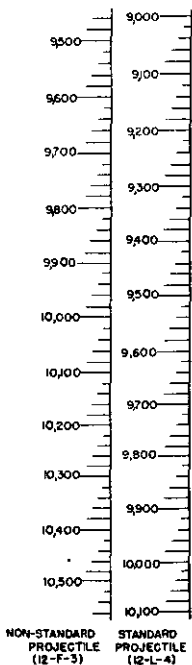

FIGURE 103.—Range-range relation scale.

■ 14. CHARTS FOR RANGE CORRECTION BOARDS (fig. 104).—The charts for range correction boards provide a convenient means for determining graphically range corrections due to

various nonstandard ballistic conditions expressed in terms of percent of the range. Each group of curves on these charts is plotted with rectangular coordinates, the ordinates being ranges and the abscissas the range effects in terms of percent of the range. In paragraph 8 (fig. 97) the process of constructing an elementary chart of this type was described, although in this case range effects were plotted in yards instead of in percent. Also, figure 98 showed only the range effects of an increase in muzzle velocity, while a completed chart gives the effects due to velocities both above and below normal. The scale of abscissas used for these charts is 1 inch equals 2 percent. The ordinate scale is variable and is chosen so as to obtain the proper shape of the correction curves. The data shown in columns 1, 2, and 5 in the table following were extracted from Firing Tables 12-F-3. The data in columns 4 and 7 were computed and furnish sufficient data to plot the curves for velocities 50 foot-seconds greater and less than normal.

1	2	3	4	5	6	7
Range (yards)	Effect of +50 f. s. (yards)	Effect expressed as percent	Scale distance (inches)	Effect of -50 f. s. (yards)	Effect expressed as percent	Scale distance (inches)
1,000.....	+42	+4.20	2.10	-41	-4.10	2.05
5,000.....	+201	+4.02	2.01	-199	-3.98	1.99
10,000.....	+379	+3.79	1.90	-376	-3.76	1.88
15,000.....	+534	+3.56	1.78	-529	-3.52	1.76
20,000.....	+676	+3.38	1.69	-670	-3.35	1.68
25,000.....	+817	+3.27	1.64	-809	-3.24	1.62
30,000.....	+984	+3.28	1.64	-968	-3.23	1.62

Using the same scales for abscissas and ordinates, but using different origins, separated at convenient distances along the horizontal line of the chart representing zero range, there are plotted the several similar groups of curves. Figure 104 shows the groups for muzzle velocity and elasticity effects. Charts usually contain in addition groups of

curves which give the range effects of variations in density, height of site, wind, weight of projectile, and rotation of the earth (where applicable). On the right edge of the chart, three nonuniform scales are plotted giving the time of flight, probable error in range, and angle of fall for the various ranges. On some charts an additional scale, showing the meteorological zone, is added at the left of the time of flight scale. All the data necessary to plot any of these curves or scales may be obtained from the appropriate firing tables.

It should be noted that while the abscissas used in plotting the curves are range effects, these effects are changed to corrections when the range correction board is operated, the correction scale being graduated with readings increasing from right to left for that purpose. The values of the corrections (in percent of the range) are shown at the lower edge of figure 104, positive to the left and negative to the right of the origin.

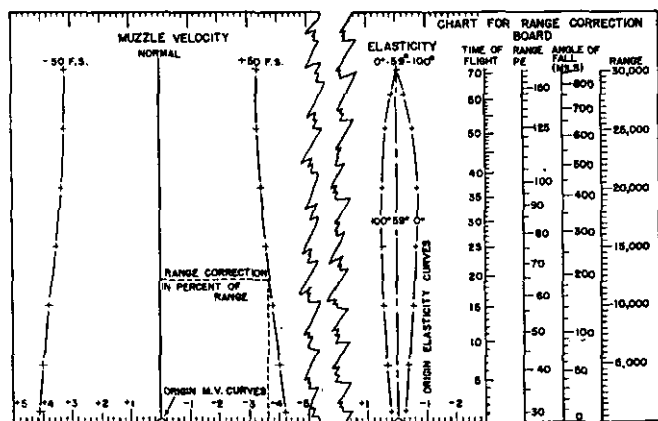

FIGURE 104.—Chart for range correction board.

■ 15. CHARTS FOR DEFLECTION BOARD M1 (fig. 106).—Charts are issued for use with the deflection board M1, by which deflection corrections due to wind, drift, and rotation of the earth are determined graphically. The plotting of these charts is somewhat unusual in that neither rectangular nor

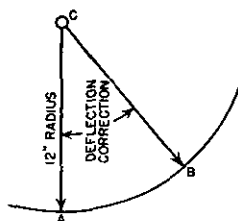

FIGURE 105.—Deflection correction elements, deflection board M1.

polar coordinates are used, but a combination of the two is employed. The construction and operation of the deflection board M1 itself must be understood before considering its charts. Figure 13 shows the essentials of the deflection board by which the deflection corrections are determined.

A and B represent two movable pointers each of 12-inch radius and each pivoted at the point C. The board is so constructed that the angle between these pointers is the total deflection correction due to wind, drift, and rotation of the earth plus a certain constant value of construction. The constants are introduced so that more than one set of wind and drift curves may be drawn on the same chart. There are three variables for which deflection corrections must be determined. Drift, the first, is assumed to vary only with the range. Wind corrections vary according to the range and the velocity of the cross wind component of the ballistic wind. Corrections for rotation of the earth vary with the azimuth of the target, the range, and the latitude, but all charts are plotted on the assumption that the latitude is constant and is 30° N. Thus these corrections are assumed to depend upon only two variables, the range and the azimuth of the target. The data in the following table are sufficient for the construction of a chart for the deflection board M1

(deflection corrections in degrees for 10-inch gun, M1888 firing HE shell, Mk. II (Firing Tables 10-A-1, MV=2,400 f. s.)).

Range (yards)	Drift correc- tions (degrees)	Cross wind (miles per hr.)					Corrections (degrees) due to rotation of earth at lat. 30° N.		
		10	20	30	40	50	Azimuth 0 and 360	90 and 270	180
		Corrections (degrees)							
0.....	0	0	0	0	0	0	0	0	
5,000.....	-.10	.04	.09	.13	.18	.22	-.02	-.02	-.02
10,000.....	-.20	.09	.19	.28	.38	.47	-.03	-.03	-.03
15,000.....	-.35	.15	.31	.46	.62	.77	-.05	-.06	-.06
20,000.....	-.65	.22	.44	.66	.89	1.11	-.07	-.09	-.10
25,000.....	-1.15	.29	.57	.86	1.14	1.43	-.09	-.13	-.18
26,000.....	-1.35	.30	.60	.90	1.20	1.50	-.09	-.15	-.20
Source	Column 14, part 2, table A.	Part 2, table J					Part 2, table K.		

The completed chart, figure 106, is mounted on two parallel rollers in such a way that the center line of the chart is always in prolongation of a radius from the center of the deflection board. By turning one roller the chart may be moved in toward or out away from the center of the board, thus placing a new portion of the chart under the pointers A and B, figure 105. This motion of the chart corresponds to a change of ordinates, and therefore the ordinate scale, measured along a vertical line of the chart, is parallel to the center of the chart. At suitable intervals along the vertical center line of the chart, points are selected as the centers for the construction of arcs of 12-inch radii. Thus in figure 106, the arc cutting the range scale at the point of zero range was constructed with its center at A, the arc for 5,000 yards has its center at B, and so forth. Now, if the chart is placed in the instrument without rolling, when the point A

is under the center of the board *C* (fig. 105) the pointers *A* and *B* (fig. 105) will fall somewhere along the arc cutting the range scale at the point of zero range. The amount of the deflection correction at any selected range is laid off to scale along the corresponding arc. It can be seen that

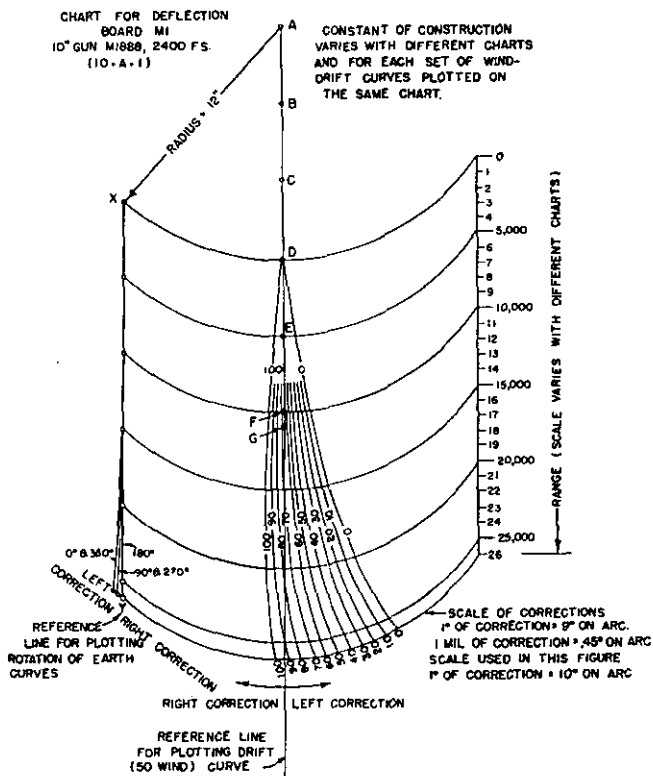

FIGURE 106.—Chart for deflection board M1 for 10-inch gun, M1888.

there are two coordinates used in the plotting of curves. The ordinate scale is uniform for any one chart, varies with different charts, is graduated according to range, and is constructed along a line parallel to the center vertical line of the

chart. The other variable is measured along arcs with centers on the vertical center line of the chart. The radius of each arc is 12 inches, but in the construction of figure 106 these radii were reduced for convenience. Two scales are used to plot along these arcs depending upon whether mils or degrees are used. In the first case 200 mils of deflection correction equal 90° on the arcs, and in the second case 10° of deflection correction equal 90° on the arcs.

The scale selected for the range scale is that 1 inch equals 5,000 yards (reduced for convenience in fig. 106). The range scale is constructed, and then the points *A, B, C, D, E, F,* and *G* are determined to give the position of the centers of the arcs corresponding to the ranges in the first column of the table above. On actual charts, the range scale must be displaced down by $\frac{1}{2}$ inch. This is necessary because the range pointer is lowered by this amount so that the pointer *B* may swing around and still clear the range pointer. The arcs corresponding to the points *A* to *G*, inclusive, are then constructed. Two vertical lines *AG* and *XY* are then drawn at any convenient distance apart. These lines are used as reference lines, one in the construction of the wind and drift curves and the other in the construction of the rotation of earth curves. The distance between these lines measured along the arc *XD* is constant, represents a zero deflection correction, and is the constant value previously mentioned.

NOTE.—In the instructions for adjusting the deflection board it will be found that this constant is eliminated by the use of an adjustment which makes the value of the deflection correction zero, when the pointers *A* and *B*, fig. 105, are separated by the amount *XD*, fig. 106.

The board is so constructed that when these two pointers are separated by a greater amount than *XD*, the correction will be a *left* correction, and when the pointers are separated by less than *XD* a *right* correction is indicated. Therefore, effects which call for left corrections must be plotted to the right of the reference line *AG* and to the left of the reference line *XY*. Conversely, effects which call for right corrections are plotted to the left of the reference line *AG* and to the right of the reference line *XY*.

Using a protractor of the proper radius, the various curves may now be plotted, bearing in mind the scale of plotting to be used. In figure 106, the usual scale of 10° correction equals 90° on the arcs was changed, and the curves were plotted to the scale that 10° correction equals 100° on the arcs. First plot the curve marked 50. This curve gives the deflection corrections for wind and drift when the wind reference number is 50; that is, when the lateral wind component is zero. Thus this curve represents drift corrections only and is plotted from the values listed in the second column of the table above. The several points on the 5,000, 10,000, 15,000, 20,000, 25,000, and 26,000 arcs are plotted 1, 2, 3.5, 6.5, 11.5, and 13.5 degrees, respectively, to the right of the line *AF*, since drift corrections are to the left. Using the points where this curve crosses the arcs as reference points, the remainder of the wind curves may be plotted. For example, at 15,000 yards the curve marked 0 (a 50-mile wind from the left) must be plotted $0.77 \times 100/10 = 7.7^\circ$ to the right of the point where the 50 curve crosses the 15,000-yard arc. The curves for the rotation of the earth corrections are plotted in the same manner. It will be noted that for ranges below 15,000 yards, one curve serves equally well for all azimuths for this gun.

When one battery is supplied with two different kinds of ammunition or fires with more than one muzzle velocity, charts are issued for the deflection board with two groups of wind-drift curves, one for each combination of powder charge and projectile. The construction of these charts is essentially as described above. The second set of curves is plotted using another vertical line as the reference line, and consequently when these curves are used the board must be reset to eliminate the new constant angle of construction.

a. Equation for range deviation TG :

$$AT = R^2 \tan \Delta S^2$$

$$CT = AT / \cos (90^\circ - T) = AT / \sin T = R^2 \tan \Delta S^2 / \sin T$$

$$TD = CT \cos T^1 = R^2 \tan \Delta S^2 \cos T^1 / \sin T$$

$$BT = R^1 \tan \Delta S^1$$

$$TF = BT / \cos (90^\circ - T) = BT / \sin T = R^1 \tan \Delta S^1 / \sin T$$

$$CS = TF = R^1 \tan \Delta S^1 / \sin T$$

$$DG = ES = CS \cos T^2 = R^1 \tan \Delta S^1 \cos T^2 / \sin T$$

$$TG = TD + DG$$

$$TG = \frac{R^2 \tan \Delta S^2 \cos T^1}{\sin T} + \frac{R^1 \tan \Delta S^1 \cos T^2}{\sin T} \quad (1)$$

b. Equation for lateral deviation GS :

$$BT = R^1 \tan \Delta S^1$$

$$TF = BT / \cos (90^\circ - T) = R^1 \tan \Delta S^1 / \sin T$$

$$CS = TF$$

$$CE = CS \sin T^2 = R^1 \tan \Delta S^1 \sin T^2 / \sin T$$

$$AT = R^2 \tan \Delta S^2$$

$$CT = AT / \cos (90^\circ - T) = R^2 \tan \Delta S^2 / \sin T$$

$$CD = CT \sin T^1 = R^2 \tan \Delta S^2 \sin T^1 / \sin T$$

$$GS = CE + (-CD)$$

$$GS = \frac{R^1 \tan \Delta S^1 \sin T^2}{\sin T} + \frac{R^2 \tan \Delta S^2 \sin T^1}{\sin T} \quad (2)$$

Formulas (1) and (2) may be rewritten as follows:

$$TG = \pm \frac{R^1 \cos T^2}{\sin T} \tan \Delta S^1 \pm \frac{R^2 \cos T^1}{\sin T} \tan \Delta S^2 \quad (3)$$

$$GS = \pm \frac{R^1 \sin T^2}{\sin T} \tan \Delta S^1 \pm \frac{R^2 \sin T^1}{\sin T} \tan \Delta S^2 \quad (4)$$

For application of these formulas to the deflection board M2 see paragraph 123 (ch. 13).

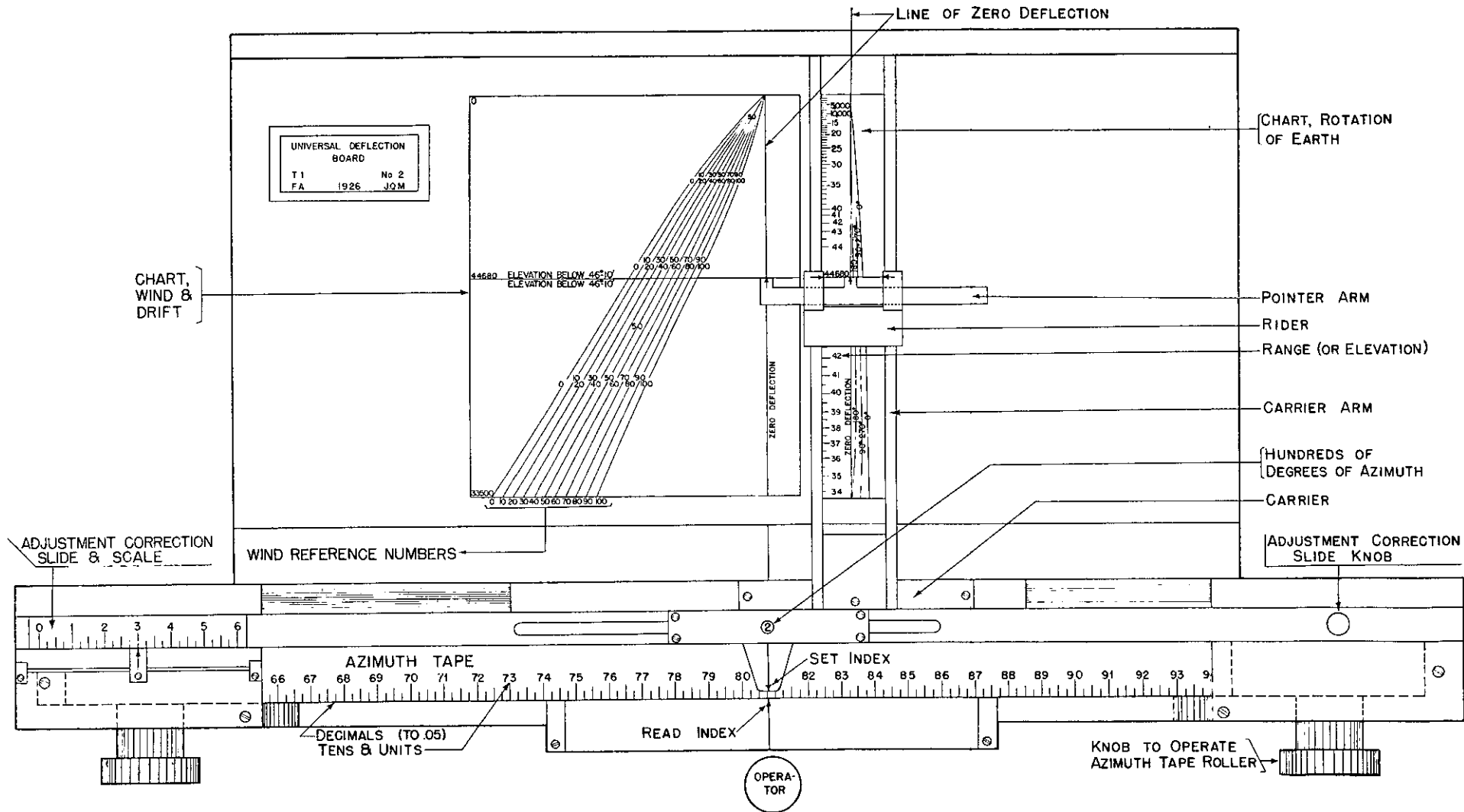
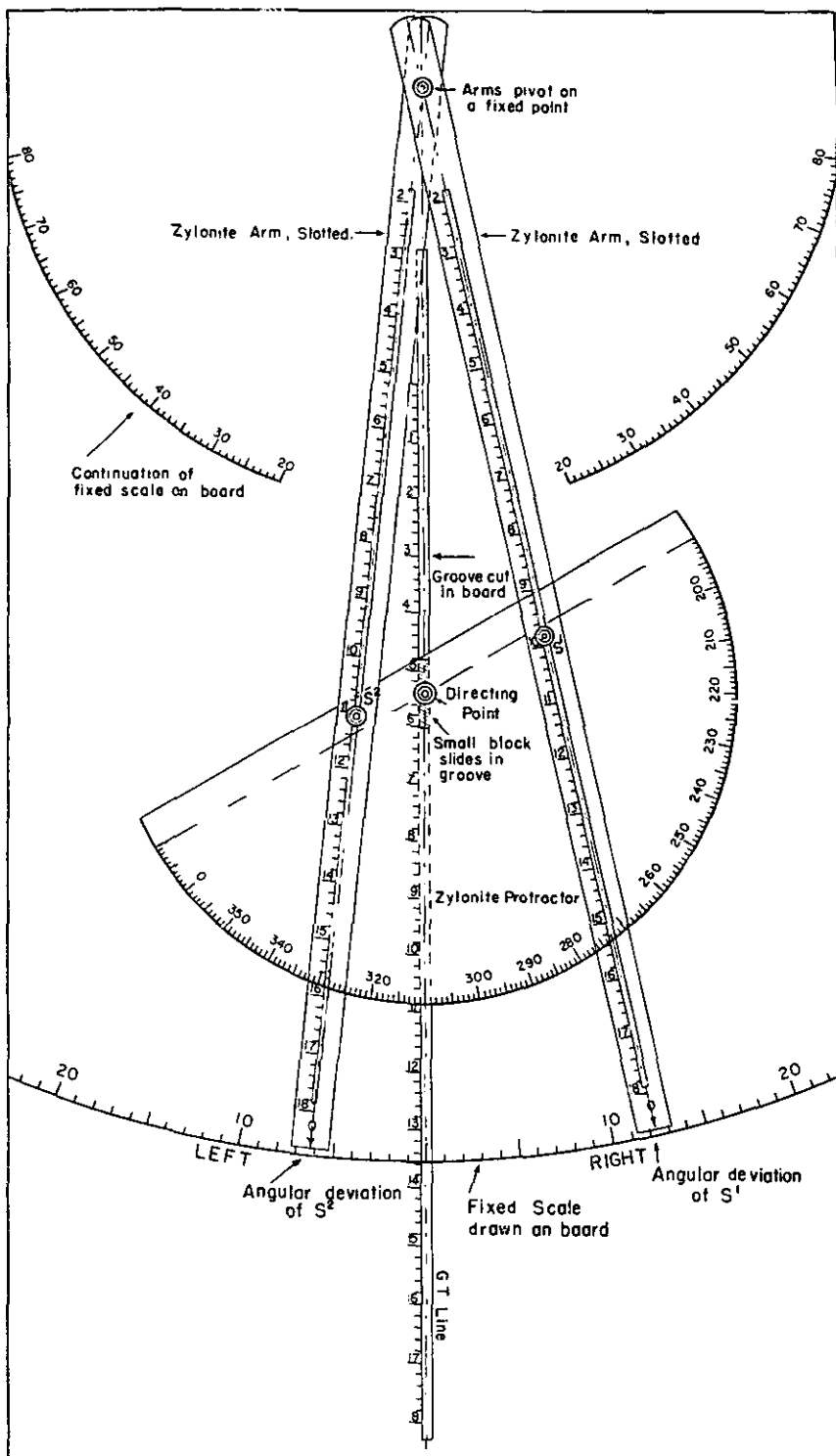

FIGURE 49.—Universal deflection board.



**DATA DEVICE
FOR USE WITH COLE SPOTTING BOARD**

OPERATION:

- (a) Move protractor along G-T line until circumferential edge is opposite range called by plottor
- (b) Turn protractor until azimuth called from plotting board is opposite G-T line
- (c) Read angular deviations of S^1 and S^2 from G-T line (nearest degree) and distances to target (nearest 200 yards) direct and apply to spotting board (For convenience set zero of azimuth circle on spotting board opposite G-T line and leave stationary.)

NOTE The directing point being fixed, any number of observing stations may be located on zylonite protractor by knowing their azimuths and distances from the directing point of the battery firing

FIGURE 59.—Data device for Cole spotting board.

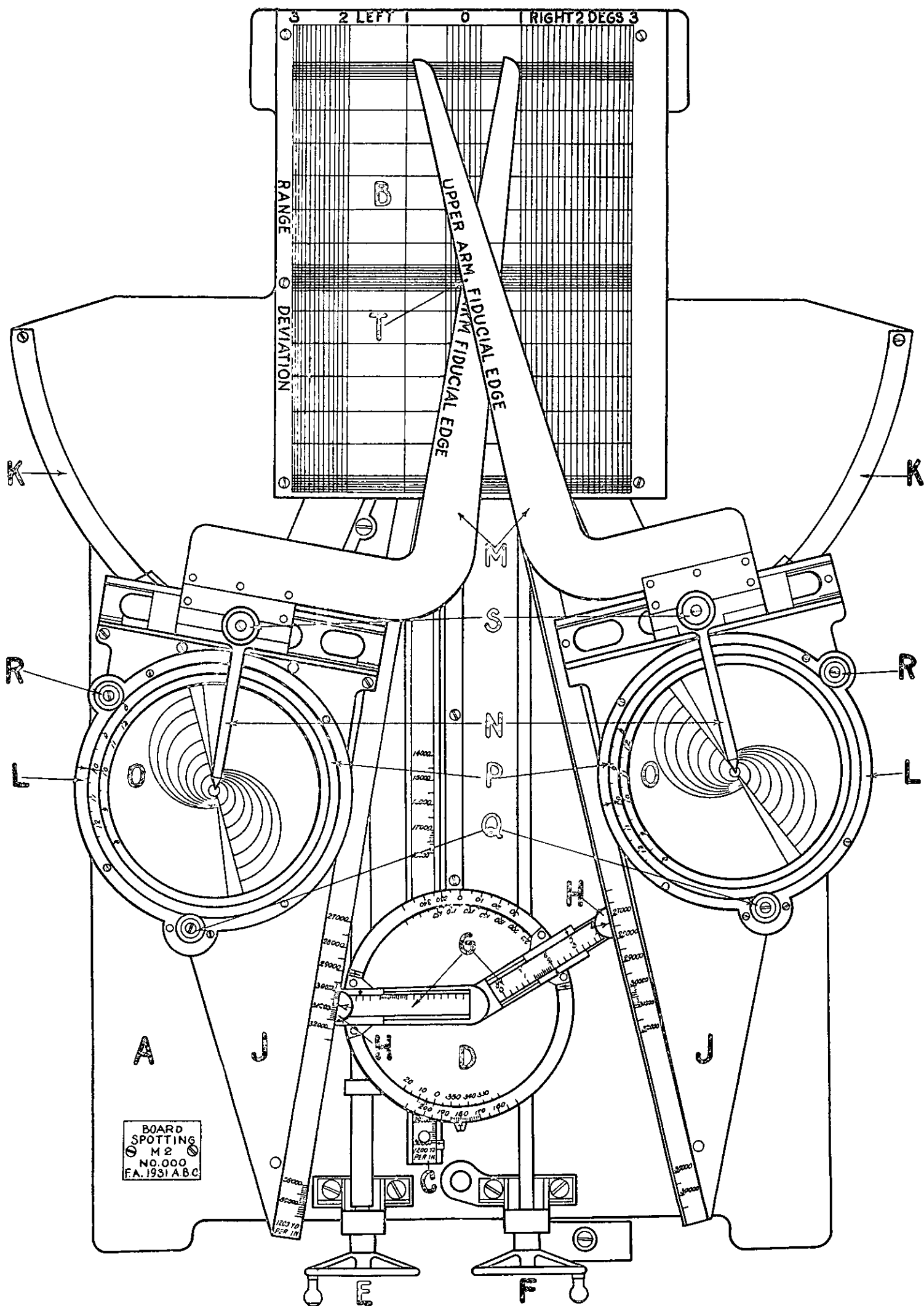

FIGURES 61.—Spotting board M2.

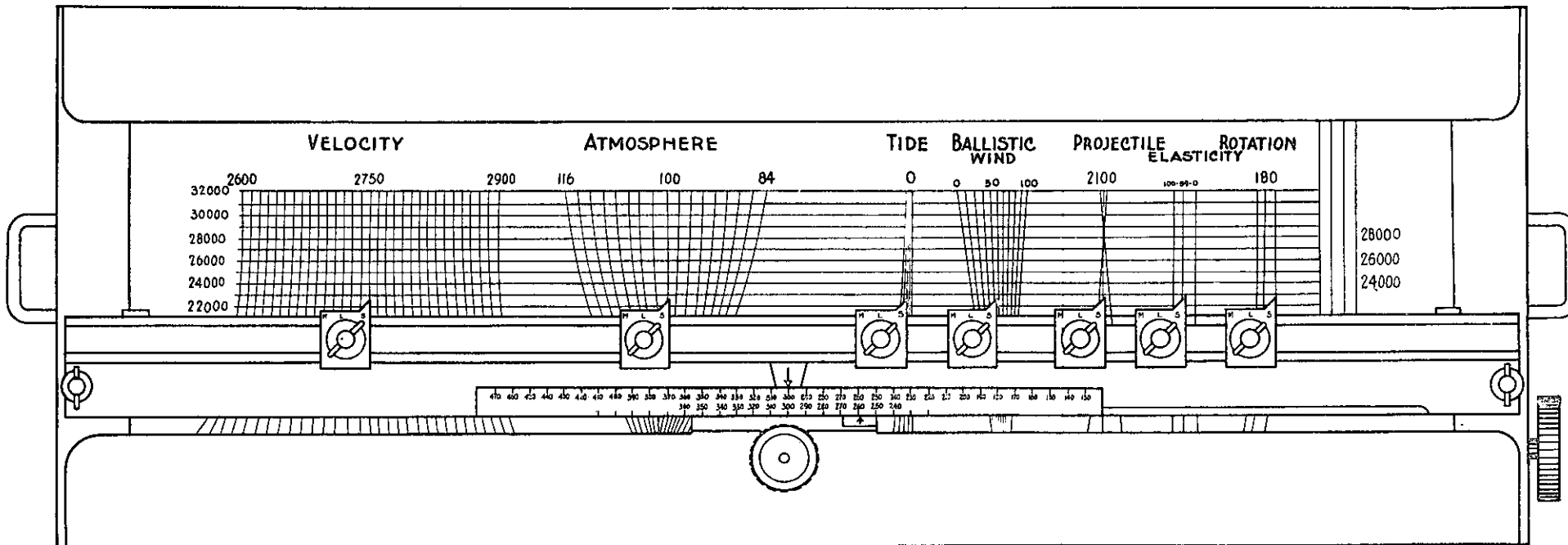

FIGURE 43.—Range correction board M1.

APPENDIX IV

DATA

■ 1. DISTANCES TO THE HORIZON.

Height of site:

<i>Feet</i>	<i>Distance Yards</i>
25	11,600
30	12,700
35	13,800
40	14,700
45	15,600
50	16,400
55	17,300
60	18,000
65	18,800
70	19,500
75	20,100
80	20,800
85	21,500
90	22,100
95	22,700
100	23,300
150	28,500
200	32,900
250	36,800
300	40,300
400	46,500

■ 2. CIRCULAR SYSTEM; EQUIVALENTS IN DEGREES, MINUTES, AND MILS.—In the circular system, an arc of a circle is laid off equal in length to the radius. The angle at the center subtended by this arc is taken as the unit angle and is called a radian.

The circumference of a circle is 2π times the radius. There are then 2π radians in a circle.

1 radian equals $57^{\circ} 17' 45''$.

1 radian equals 1018.6 mils.

1 degree equals 0.0174533 radians.

1 minute equals 0.0002909 radians.

1 mil equals 0.0009817 radians.

APPENDIX V

LIST OF REFERENCES

The following references contain additional information on the subject matter of this manual:

- Orientation ----- TM 4-225 (now
published as TM 2160-25).
Stereoscopic range and height finding ----- TM 4-250.
Seacoast artillery—gunnery ----- FM 4-10.
Reference data, seacoast artillery and anti-
aircraft artillery. FM 4-155.
Major items of harbor defense and railway
artillery sighting equipment, and fire con-
trol instruments. SNL F-2,
part II.
Other standard nomenclature lists in group F which are re-
ferred to specifically in SNL F-2, part II.
Notes on matériel, data transmission system T11 (M5), pub-
lished under the direction of the Chief of Ordnance.
Pertinent handbooks, pamphlets, and other Ordnance De-
partment publications on specific items of equipment.

INDEX

	Paragraphs	Pages
Adjustment of fire:		
Bracketing adjustment chart.....	140-142	184
Fire adjustment board M1.....	136-139	189
Adjustments:		
Direction:		
Fixed artillery.....	179	249
Mobile artillery.....	180	252
Elevation:		
Fixed artillery.....	177	245
Mobile artillery.....	178	249
Aerial:		
Fire control.....	143-148	201
Spotting.....	128-135	184
Aiming:		
Point for tracking.....	9	6
Rule.....	174	239
Alternate:		
Base lines.....	17	13
Stations.....	17	13
Angular:		
System.....	11	8
Travel:		
Computer.....	105-106, 214	151, 287
Reference numbers.....	54	73
Units.....	12	9
Approximate data.....	210	284
Areas, water, harbor defense.....	6	2
Armament:		
Fixed.....	4	1
Mobile.....	4	1
Primary.....	4	1
Secondary.....	4	1
Artillery, seacoast.....	4	1
Assignment of target.....	5-8	2
Atmospheric refraction.....	44-47	46
Axis of bore, determination of azimuth of.....	176	244
Azimuth.....	11	8
Adjustment slide rule.....	111-112	167
Circles.....	175	243
Difference.....	26, 28, 29	21, 22
Chart.....	30, 31	22, 27
Firing.....	25	20
Instruments.....	41-43	41
M1910A1 and M1910.....	42	41
M1918.....	43	46
Measurement.....	11-12	8
Uncorrected.....	21	16

INDEX

	Paragraphs	Pages
Ballistic:		
Conditions:		
Corrections for nonstandard.....	85	121
Necessity for.....	23	18
Density.....	79, 85	113, 121
Wind.....	79, 85	113, 121
Base:		
Horizontal.....	14	9
Line.....	14	9
Alternate.....	17	13
Ring, check of level.....	162	218
Self-contained.....	16	12
Vertical.....	15	12
Bells, time interval.....	13	9
Board:		
Deflection:		
M1905 (for guns).....	94-96	132
M1906 (for mortars).....	97-100	141
M1.....	107-110	154
Universal.....	101-104	145
Fire adjustment M1.....	136-139	189
Plotting:		
M1904 (Whistler-Hearn).....	67-69, 213	84, 286
Mortar:		
M1906 and M1906MI.....	70	92
M1911 (360°).....	71	92
110°, M1915, M1918, and M3.....	72-74, 207-211	93, 281
Plotting and relocating:		
M1.....	75-77, 213	98, 286
M1923 (Cloke).....	75-77, 213	98, 286
Range correction.....	25	20
M1.....	83-86	119
M1923.....	89	124
M1923, modified.....	90	124
Pratt, M1905 (modified).....	88	124
Spotting:		
Cole.....	120	177
Gray, early model.....	118	174
Gray, modified model.....	119	177
M2.....	121-126	178
Boresighting.....	170	228
Bracketing adjustment chart.....	140	194
Grid type.....	141-142	195
Ray type.....	141-142	195
Buglers.....	196	275
Duties in fire control.....	197	275
Cases of pointing.....	158	216
Charts:		
Azimuth difference.....	30, 31	22, 27
Bracketing adjustment.....	140	194
Grid type.....	141-142	195
Ray type.....	141-142	195
Construction, for fire control instruments.....	App. II	297
Elevation difference.....	35	32
Range difference.....	33	29
Set-forward.....	62-63	78

INDEX

	Paragraphs	Pages
Circles:		
Azimuth	175	243
Azimuth difference	31	26
Circular system, equivalents	App. IV	325
Classification of ships	5	2
Clinometer	159, 161	216, 217
Rest	159, 161	216, 217
Coincidence:		
Range finders	49-51	65
Range finding method	48	58
Commands:		
Contents	7	4
Examples	8	5
Communication, fire control	181-188	258
Computer, angular travel	105-106, 214	159, 287
Conduct of fire	4	1
Construction of charts and scales for seacoast artillery fire control instruments	App. II	297
Control, fire	4	1
Communication	171-188	258
Coordinates:		
Polar	App. II	297
Rectangular	App. II	297
Coordination of timing	40	40
Correction devices:		
Direction	93-112	131
Range	78-92	112
Corrections:		
Atmospheric density	24, 85	18, 121
Atmospheric temperature (elasticity)	24, 85	18, 121
Azimuth	25, 36	20, 35
Ballistic	23, 85	18, 121
Curvature of the earth	44-47	46
Deflection	25	20
Direction	36	35
Displacement	36, 37	35, 36
Drift	25	20
Elevation	37	36
Errors in level of base ring	162	218
Height of site (including tide)	24, 85	18, 121
Lateral adjustment	216	287
Muzzle velocity (including powder tempera- ture)	24, 85	18, 121
Range	24, 37	18, 36
Range adjustment	216	287
Refraction	44-47	46
Rotation of the earth	24, 25, 85	18, 20, 121
Tide	24, 44-47	18, 46
Weight of projectile	24, 85	18, 121
Wind	24, 25, 85	18, 20, 121
Corrector:		
Percentage	24	18
M1	91-92	124
Curvature of the earth, corrections	44-47	46

INDEX

Data:	Paragraphs	Pages
Approximate	210	284
Circular system, equivalents	App. IV	325
Distances to horizon	App. IV	325
Firing:		
Corrected	211	285
Uncorrected:		
Determination	22	17
Elements	21	16
Transmission system M5 (formerly T11), electrical	186	258
Transmitters:		
Electrical	186	258
Mechanical	185	258
Dead time	10	7
Definitions	App. I	289
Deflection:		
Board	25	20
Construction of charts	App. II	297
M1	107-110	154
M1905 (for guns)	94-96	132
M1906 (for mortars)	97-100	141
Universal	101-104	145
Corrected	24	18
Defined	157	216
Firing	25	20
Reference numbers	53	72
Rule for	93	131
Uncorrected	21	16
Degree	12	9
Density, ballistic, corrections	24, 85	18, 121
Depression:		
Position finder	15, 41, 44-47	12, 41, 46
M1907	46	52
M1	47	57
Swasey	45	49
Depression angle method of range finding	15, 44	12, 46
Designation, target	5-8	2
Details:		
Observing	190	266
Duties	192	269
Plotting room	190	266
Duties	194	270
Range section	192-194	269
Spotting	190	266
Duties	193	269
Devices, visual signal	188	264
Difference:		
Azimuth	26, 28	21
Chart:		
Azimuth	30, 31	22, 27
Elevation	35	32
Range	33	29
Circles	31	27
Elevation	26, 34	21, 31
Gun	26	21
Range	26, 32	21, 29

INDEX

	Paragraphs	Pages
Directing:		
Gun -----	26	21
Point -----	26	21
Direction:		
Adjustments:		
Fixed artillery -----	179	249
Mobile artillery -----	180	252
Corrections -----	36	35
Fire -----	4	1
Pointing methods -----	157, 169-176	216, 228
Displacement -----	26-37	21
Gun -----	26	21
Corrections for -----	36, 37	35, 36
Distances to horizon -----	App. IV	325
Elasticity corrections -----	24, 85	18, 121
Electrical data transmission system M5 (formerly T11) -----	186	258
Elevation:		
Adjustments:		
Fixed artillery -----	177	245
Mobile artillery -----	178	248
Angle of -----	156	215
Difference -----	26, 34	21, 31
Chart -----	35	32
Pointing methods -----	156, 159-168	215, 216
Scales -----	168	228
Emergency fire control systems -----	18	13
Aerial -----	143-148	201
One-station -----	149-154	209
Equivalents, circular system -----	App. IV	325
Examples of adjustments:		
Direction:		
Fixed artillery -----	179	249
Mobile artillery -----	180	252
Elevation:		
Fixed artillery -----	177	245
Mobile artillery -----	178	248
Fire:		
Adjustment:		
Board M1 -----	136-139	189
Corrections method -----	139	193
Standard method -----	138	191
Conduct of -----	4	1
Control -----	4	1
Communication -----	181-188	258
Personnel -----	196-197	274
Training -----	198-206	276
System:		
Aerial -----	143-188	201
Emergency, one-station -----	149-154	209
Direction -----	4	1

INDEX

	Paragraphs	Pages
Firing:		
Azimuth.....	25	20
Data.....	25	20
Corrected.....	24-25	18
Uncorrected:		
Determination.....	22	17
Elements.....	21	16
Deflection.....	25	20
Elevation.....	24	18
Range.....	24	18
Fixed armament.....	4	1
Flags.....	188	264
Functioning:		
Position finding systems.....	207-215	281
Spotting system.....	216	287
Glossary.....	App. I	289
Gun:		
Difference.....	26	21
Directing.....	26	21
Displacement.....	26	21
Parallax.....	26	21
Gunner's quadrant:		
M1.....	167	225
M1918.....	167	225
Older models.....	167	225
Harbor defense water areas.....	6	2
Height of site corrections.....	24, 85	18, 121
Horizon, distances to.....	App. IV	327
Horizontal base system.....	14, 17	9, 13
Hypothetical courses, use in training.....	148, 164, 204	207, 218, 278
Identification of target.....	5-8	2
Indication of target.....	5-8	2
Indicator, wind component.....	78-82, 93, 215	112, 131, 287
Azimuth.....	41-43	41
M1910A1 and M1910.....	42	41
M1918.....	43	46
Observation.....	41-51	41
Pointing.....	155-180	215
Self-contained base.....	48-51	58
Interpolator, percentage corrector.....	91	124
Interval:		
Firing.....	39, 40	39, 40
Observing.....	13, 39, 40	9, 39, 40
Predicting.....	39	39
Jumping splashes.....	117	171
Lamps, signal (projectors).....	188	264
Lateral adjustment corrections.....	216	287
Level of trunnions.....	169	228
Logarithmic scales.....	App. II	297
Measurement of azimuth.....	11-12	8
Mechanical data transmitters.....	185	258
Meteorological message.....	79, 208	113, 282

INDEX

	Paragraphs	Pages
Mil.-----	12	9
Mobile armament-----	4	1
Muzzle velocity corrections-----	24, 85	18, 121
Naval targets, classification-----	5	2
Numbers, reference-----	52-56	72
Observation instruments-----	41-51	41
Azimuth instruments-----	42-43	41
Depression position finders-----	44-47	46
Self-contained range finders-----	48-51	58
Observation of fire. (See Spotting.)		
Observers-----	190	266
Base end:		
Duties-----	192	269
Training-----	200	276
Battery commander's-----	197	275
Spotting-----	115, 190	170, 266
Duties-----	193	269
Training-----	201	277
Observing:		
Details-----	190	266
Duties-----	192	269
Interval-----	13	9
Points-----	9	6
Orientation of guns and sights-----	176, 179-180	244, 249
Panels-----	188	264
Panoramic telescopes-----	173	232
Parallax-----	26, 28, 29, 43	21, 22, 46
Gun-----	26	21
Percentage corrector M1-----	91-92	124
Construction of charts-----	App. II	297
Plotted point-----	14	9
Plotter:		
Duties-----	194	270
Training-----	199	276
Plotting board:		
M1904 (Whistler-Hearn)-----	67-69, 213	84, 286
Mortar:		
M1906 and M1906MI-----	70	92
M1911 (360°)-----	71	92
110°, M1915, M1918, and M3-----	72-74, 207-211	93, 281
Plotting and relocating board:		
M1-----	75-77, 213	98, 286
M1923 (Clove)-----	75-77, 213	98, 286
Plotting room details-----	190	266
Duties-----	194	270
Point:		
Aiming-----	9	6
Datum, defined-----	App. I	289
Directing-----	26	21
Observing-----	9	6
Plotted-----	14	9
Predicted-----	20	15
Set forward, location-----	10, 19	7, 14

INDEX

	Paragraphs	Pages
Pointing:		
Case I.....	158	216
Case II.....	158	216
Case III.....	158	216
Defined.....	155	215
Instruments.....	161-175	217
Methods:		
Direction.....	157, 169-176	216, 228
Elevation.....	156, 159-168	215, 216
Tests.....	206	279
Position finder:		
Depression.....	41, 44-47	41, 46
M1907.....	46	52
M1.....	47	57
Swasey.....	45	49
Position finding:		
System:		
Functioning.....	207-216	281
Functions.....	10	7
Timing.....	38-40	38
Predicted point, location.....	20	15
Prediction:		
Methods.....	13-16, 19, 20, 69	9, 14, 15, 89
Scale.....	57-58, 212	74, 286
Tests.....	205	278
Primary armament.....	4	1
Projectile, weight, corrections.....	24, 85	18, 121
Projectors (signal lamps).....	188	264
Pyrotechnics.....	188	264
Quadrant elevation.....	21, 156	16, 215
Quadrants:		
Elevation:		
M1908 (for mortars).....	164	221
M1917.....	165	222
Gunner's:		
M1.....	167	225
M1918.....	167	225
Older models.....	167	225
Quadrant sight, M1918A1.....	166	224
Range:		
Adjustment corrections.....	216	287
Correction board.....	24, 78	18, 112
Construction of charts.....	App. II	297
M1.....	83, 86	119, 123
M1923.....	89	124
M1923, modified.....	90	124
Pratt, M1905 (modified).....	88	124
Correction devices.....	78-92	112
Functions.....	78	112
Percentage corrector M1.....	91-92	124
Range correction boards.....	83-90	119
Wind component indicator.....	80-82	116
Corrections.....	24	18
Reference numbers.....	56	73
Deviation reference numbers.....	56	73

INDEX

Range—Continued.	Paragraphs	Pages
Difference	26, 32	21, 29
Chart	33	29
Disks	163	219
Finder, self-contained	41, 48-51	41, 58
Coincidence type	49-51	65
Stereoscopic type	49-51	65
Firing	24	18
Section	189-194, 198-206	266, 278
Duties	191-194	268
Organization	190	266
Radio system, fire control communication	183	258
Reader:		
Base end:		
Duties	192	269
Training	200	276
Spotting:		
Duties	193	269
Training	201	277
Reference numbers	52-56	72
Refraction corrections	44-47	46
Relocation	10, 26, 27	7, 21
Rest, clinometer	159, 161	216, 217
Scales:		
Construction for fire control instruments	App. II	297
Elevation	168	228
Logarithmic range:		
Construction	App. II	297
Use	91	124
Prediction	57-58, 208	74, 282
Range-elevation relation:		
Construction	App. II	297
Use	91	124
Range-range relation:		
Construction	App. II	297
Use	91	124
Set-forward	64-65	80
Seacoast artillery	5	2
Secondary armament	4	1
Self-contained base:		
Range finder	41, 48-51	41, 58
System	9, 16	6, 12
Set-forward:		
Chart	62-63	78
Point, location	10, 19	7, 14
Rule	59-61	75
Scales	64-65	80
Ships, classification	5	2
Sight, quadrant, M1918A1	166	224
Sights, telescopic	172	230
Signaling system:		
Electrical	187	264
Visual	188	264
Signal lamps (projectors)	188	264
Silhouettes, use	5	2
Slide rule, azimuth adjustment	111-112	167
Splashes, jumping	117	171

INDEX

	Paragraphs	Pages
Spotting:		
Aerial-----	128-135	184
Board:		
Cole-----	120	177
Gray, early model-----	118	174
Gray, modified model-----	119	177
M2-----	121-126	178
	App. II	297
Details-----	190, 193, 216	266, 269, 287
Devices-----	118-120	174
Methods:		
Lateral-----	116	171
Range-----	117	171
Observers-----	115	170
Duties-----	193, 216	269, 287
Training-----	201	277
Purpose-----	113	169
Readers:		
Duties-----	193, 216	269, 287
Training-----	202	277
Single station-----	117	171
Stations, location-----	114	170
Systems-----	114	170
Operation-----	216	287
Three-station-----	127	183
Two-station-----	117	171
Stations:		
Alternate-----	17	13
Spotting, location-----	114	170
Stereoscopic:		
Range finder-----	49, 51	65
Range finding method-----	48	58
Swasey depression position finder-----	45	49
System:		
Angular-----	11	7
Fire control communication-----	181-188	258
Radio (telephone and telegraph)-----	183	258
Wire (telephone)-----	182	258
Horizontal base-----	10, 14, 17	7, 9, 13
Self-contained base-----	10, 16	7, 12
Signaling:		
Electrical-----	187	264
Visual-----	188	264
Spotting-----	113-135	169
Operation-----	216	287
Vertical base-----	10, 15	7, 12
Targ-----	68	83
Target:		
Assignment-----	5-8	2
Designation-----	5-8	2
Identification-----	5-8	2
Indication-----	5-8	2
Testing-----	173	232
Telephone operators-----	196	275
Duties in fire control-----	197	275
Telephone system, fire control communication-----	182	258

INDEX

	Paragraphs	Pages
Telescopes:		
M1912.....	172	230
Panoramic, suitable for seacoast artillery.....	173	232
Straight (formerly called telescopic sight).....	172	230
Temperature corrections.....	24	18
Terrestrial spotting stations.....	114	170
Testing target.....	173	232
Tests:		
Pointing.....	206	279
Prediction.....	205	278
Tide corrections.....	24, 44-47, 85	18, 46, 121
Time interval.....	39	39
Bells.....	13	9
Timing:		
Coordination.....	40	40
Position finding system.....	38-40	38
Tracking.....	10, 13-18	7, 9
Common principles.....	13	9
Horizontal base.....	14, 69	9, 89
Self-contained base.....	15, 69	12, 89
Vertical base.....	16, 69	12, 89
Training:		
Aerial position finding personnel.....	148	207
Emergency one-station position finding personnel.....	154	213
Fire control and position finding personnel.....	198-206	276
Transmission system:		
M5 (formerly T11) (electrical) data.....	186	258
Mechanical data.....	185	258
Trunnions, level of.....	169	228
Units, angular.....	12	9
Vertical base system.....	10, 15	7, 12
Visual signal devices.....	188	264
Water areas, harbor defense.....	6	2
Weight of projectile, corrections.....	24, 85	18, 121
Wind:		
Ballistic.....	79, 85	113, 121
Component indicator.....	78-82, 93, 215	112, 131, 287
Corrections.....	24, 80, 85	18, 116, 121
Reference numbers.....	55	73
Wire system (telephone), fire control communication.....	182	258