

MHI
Copy 3

FM 6-55

WAR DEPARTMENT

**FIELD ARTILLERY
FIELD MANUAL**



**SERVICE OF THE PIECE
75-MM GUN, M2, HORSE-DRAWN
AND TRUCK-DRAWN**

OCT 1939

**WIRC
COPY**

FM 6-5a

**FIELD ARTILLERY
FIELD MANUAL**



**SERVICE OF THE PIECE
75-MM GUN, M2, HORSE-DRAWN
AND TRUCK-DRAWN**

Prepared under direction of the
Chief of Field Artillery



UNITED STATES
GOVERNMENT PRINTING OFFICE
WASHINGTON : 1939

WAR DEPARTMENT,
WASHINGTON, *October 1, 1939.*

FM 6-55, Field Artillery Field Manual, Service of the Piece—75-mm Gun, M2, Horse-drawn and Truck-drawn, is published for the information and guidance of all concerned.

[A. G. 062.11 (6-17-39).]

BY ORDER OF THE SECRETARY OF WAR:

G. C. MARSHALL,
Chief of Staff.

OFFICIAL:

E. S. ADAMS,
Major General,
The Adjutant General.

TABLE OF CONTENTS

Section I. General.	Paragraph	Page
Purpose and scope.....	1	1
References.....	2	1
Definitions and terms.....	3	1
II. Organization.		
Composition.....	4	2
Formation.....	5	3
III. Posts; mounting and dismounting.		
Posts of the gun squad.....	6	3
To post the gun squads.....	7	4
Posts of the cannoneers.....	8	4
To post the cannoneers.....	9	4
To mount the cannoneers.....	10	4
To dismount the cannoneers.....	11	6
IV. Movements of the carriages by hand.		
Limbered or coupled.....	12	7
Unlimbered or uncoupled.....	13	7
V. Unlimbering and limbering.		
Unlimbering.....	14	8
Limbering.....	15	11
VI. Uncoupling and coupling.		
Uncoupling.....	16	13
Coupling.....	17	14
VII. Preparation for action and march order.		
To prepare for action.....	18	14
Posts of the cannoneers, carriages unlimbered (uncoupled).....	19	18
March order.....	20	19
VIII. Duties in firing.		
General.....	21	22
Chief of section.....	22	23
Gunner.....	23	27
No. 1.....	24	32
No. 2.....	25	36
No. 3.....	26	37
No. 4.....	27	39
No. 5.....	28	40
IX. Additional information on the service of the piece.		
Accuracy in laying.....	29	41
Fire at will.....	30	42
Aiming stakes.....	31	42
Correction for lateral displacement.....	32	43
Reporting errors.....	33	43
Cease firing.....	34	43
Suspend firing.....	35	43
Changes in data during firing.....	36	44
To unload the piece.....	37	44
Misfires.....	38	44
Ammunition.....	39	44

TABLE OF CONTENTS

	Paragraph	Page
Sec. IX. Additional information on the service of the piece—Continued.		
The section data board.....	40	45
Firing-jack floats.....	41	45
Firing from the wheels.....	42	45
X. Care and maintenance of matériel.		
General.....	43	46
Cleaning.....	44	47
Lubrication.....	45	50
Protection against chemicals.....	46	50
Recoil mechanism.....	47	50
Barrel assembly, breech mechanism, and firing mechanism.....	48	52
Cleaning slides.....	49	54
Dismounting recoil mechanism from carriage and care of trunnion bear- ings.....	50	55
Equilibrators.....	51	56
Wheels and wheel bearings.....	52	56
Brake mechanism.....	53	57
Firing jack.....	54	57
Automatic pole support on the M1918 limber.....	55	58
Caisson band brake.....	56	58
Sighting and fire-control equipment....	57	59

FIELD ARTILLERY FIELD MANUAL

SERVICE OF THE PIECE

75-MM GUN, M2, HORSE-DRAWN AND TRUCK-DRAWN

SECTION I

GENERAL

■ 1. PURPOSE AND SCOPE.—This manual prescribes the duties to be performed in the service of the piece by the personnel normally assigned to one gun section of the firing battery.

■ 2. REFERENCES.—*a. Description, operation, functioning, and care of matériel.*—(1) TR 1305-A; SNL C-5.

(2) TR 1305-75A (now TR 320-95); SNL C-12.

b. Description and operation of fire-control and sighting equipment.—TR 1320-C (now TR 310-20); SNL F-22; SNL F-166.

c. Ammunition.—TR 1355-75A; TR 1370-A; SNL R-1; SNL R-3.

d. Cleaning and preserving materials.—TR 1395-A; SNL K-1.

e. The field artillery driver.—Part Two, FM 6-5.

f. Maneuvers of the battery.—Part Two, FM 6-5.

g. Safety precautions in firing.—AR 750-10; Chapter 4, FM 6-40.

h. The firing battery.—Chapter 1, FM 6-40.

i. Gunnery.—FM 6-40.

j. Reconnaissance, occupation, and organization of position.—Part One, FM 6-20.

■ 3. DEFINITIONS AND TERMS.—*a Section.*—Tables of Organization prescribe the personnel and matériel comprising a section of a battery. In this manual the term is frequently used to designate a section of the firing battery. In this restricted sense, a gun section is composed of one piece and

the additional matériel and the personnel required to serve that piece.

b. Limbered.—A piece (caisson) is said to be limbered when its lunette is attached to the pintle of its limber.

c. Unlimbered.—A piece (caisson) is said to be unlimbered when its lunette has been detached from the pintle of the limber and the trail (caisson prop) rests on the ground.

d. Coupled.—A piece is said to be coupled when its lunette is attached to the pintle of a truck or other prime mover.

e. Uncoupled.—A piece is said to be uncoupled when its lunette is detached from the pintle of a truck or other prime mover and the trail rests on the ground.

f. Front.—The front in a section, carriages limbered or coupled, is the direction in which the trail points; carriages unlimbered or uncoupled, the direction in which the muzzle of the piece points.

g. Right (left).—The direction right (left) is the right (left) of one facing to the front.

h. In battery.—The term "in battery" is used to designate the position of the gun when it is in its normal firing position.

SECTION II

ORGANIZATION

■ 4. COMPOSITION.—*a. Gun squad.*—A gun squad consists of the gunner and five cannoneers numbered from 1 to 5. The remaining cannoneers of the gun section act as reliefs or are assigned such other duties as the chief of section may direct. When the battery unlimbers or uncouples for drill or for firing, the chief of section remains at the firing position and commands the gun squad.

b. Ammunition squad.—(1) An ammunition squad consists of an ammunition corporal and cannoneers as prescribed in Tables of Organization. These cannoneers are numbered consecutively, beginning with No. 1, and are assigned to the ammunition vehicles of the ammunition (fifth) section. In organizations equipped with caissons, the cannoneers are equally divided between the two caissons, the lower-numbered cannoneers being assigned to the first caisson.

(2) Posts and movements prescribed hereinafter for the gun squad apply, with obvious modifications, to an ammunition squad.

■ 5. FORMATION.—*a. Order of formation.*—A gun squad is formed as shown in figure 1. Higher-numbered cannoneers, if present, form in order on the left of No. 5.

b. To form.—(1) The place of formation is indicated and the command given thus, for example: 1. IN FRONT (REAR) OF YOUR PIECES (CAISSONS), or 1. ON THE ROAD FACING THE PARK, 2. FALL IN. Each gunner repeats the command FALL IN and hastens to place himself, faced in the proper direction, at the point where the right of his squad is to rest. The cannoneers move at the double time and assemble at atten-

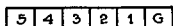

FIGURE 1.—Formation of the gun squad.

tion in their proper places. For the first formation of the gun squads for any drill or exercise, the caution, "As gun squads," precedes the command. The chief of section, if present, supervises the formation.

(2) In case the front or rear of the carriages is designated, each squad falls in at its post (par. 6).

c. To call off.—(1) The command is: CALL OFF. The cannoneer on the left of the gunner calls off "One"; the cannoneer on the left of No. 1, "Two"; and so on.

(2) After having called off, if a subsequent formation is ordered, the cannoneers fall in at once in their proper order.

SECTION III

POSTS; MOUNTING AND DISMOUNTING

■ 6. POSTS OF THE GUN SQUAD.—*a. Carriages limbered or coupled.*—(1) *In front of the piece or caisson.*—The squad is in line facing to the front, its center two paces from the end of the pole, from the heads of the lead horses, or from the front of the truck.

(2) *In rear of the piece or caisson.*—The squad is in line facing to the front, its center two paces from the muzzle of the piece or from the rear of the caisson.

b. Carriages unlimbered or uncoupled.—The squad is in rear of the piece, in line facing to the front, its center two paces from the end of the trail of the piece.

■ 7. **TO POST THE GUN SQUADS.**—The squads having been marched to the vicinity of the carriages are posted at the **COMMAND SQUADS IN FRONT (REAR) OF YOUR PIECES (CAISSONS)**. Each gunner marches his squad to its carriages and posts it in the position indicated.

■ 8. **POSTS OF THE CANNONEERS.**—*a. Carriages limbered or coupled.*—The cannoneers of the gun squad are posted as shown in figures 2 and 4. All are 2 feet outside the wheels and facing to the front. Higher-numbered cannoneers, if present, are posted as prescribed by the chief of section.

b. Carriages unlimbered or uncoupled.—See paragraph 19.

■ 9. **TO POST THE CANNONEERS.**—*a.* The command is: 1. **CANNONEERS**, 2. **POSTS**. Each gunner repeats the command **POSTS**. The cannoneers leave the ranks, if formed, and move at the double time to their posts.

b. For preliminary instruction, the squads on entering the park are first posted with their carriages, and the cannoneers are then sent to their posts by the foregoing command. The command is general, however, and is applicable when the cannoneers are in or out of ranks, at a halt or marching, and when the carriages are limbered (coupled) or unlimbered (uncoupled).

■ 10. **TO MOUNT THE CANNONEERS.**—*a.* (1) *Horse-drawn batteries.*—In each gun squad the personnel is mounted as shown in figure 3. Higher-numbered cannoneers are mounted as prescribed by the chief of section.

(2) *Truck-drawn batteries.*—In each squad the personnel is seated in the body of the truck in the order prescribed by the battery commander. The chief of section is seated beside the driver.

b. The command is: 1. **CANNONEERS, PREPARE TO MOUNT**, 2. **MOUNT**.

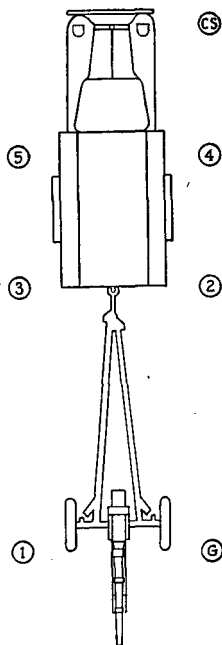
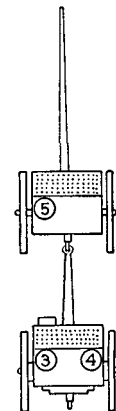
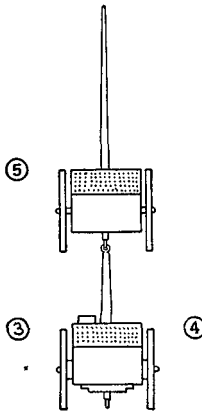
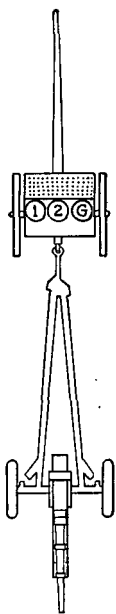
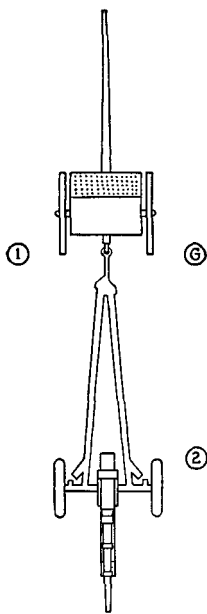

FIGURE 2.—Posts of the cannoneers, carriages limbered.

FIGURE 3.—Cannoneers mounted, horse-drawn.

FIGURE 4.—Posts of the cannoneers, carriages coupled.

(1) *Horse-drawn batteries.*—At the first command, the cannoneers who mount the limber chests and those who mount the caisson chests move at the double time to the rear and front of those chests, respectively. Each cannoneer who mounts the limber chest, except No. 2, places the foot nearest the wheel on the step, grasps the chest handle with the hand nearest the wheel, and with the other hand grasps the hand of the cannoneer opposite him. Each cannoneer who mounts the caisson chest places the foot farthest from the wheel on the caisson trail, and grasps the chest handle with the hand nearest the wheel and the hand of the cannoneer opposite him with the other hand. At the second command, all except No. 2 spring up and seat themselves, faced to the front. No. 2 then mounts and seats himself between the gunner and No. 1. Higher-numbered cannoneers, if present, mount as prescribed by the chief of section.

(2) *Truck-drawn batteries.*—At the first command, the cannoneers move at the double time to positions on the ground convenient for mounting the truck. At the second command, all mount as prescribed by the battery commander.

c. If the command is: 1. CANNONEERS, 2. MOUNT, the cannoneers execute, at the command MOUNT, all that has been prescribed for the commands CANNONEERS, PREPARE TO MOUNT and MOUNT.

■ 11. TO DISMOUNT THE CANNONEERS.—*a.* The command is: 1. CANNONEERS, PREPARE TO DISMOUNT, 2. DISMOUNT.

(1) *Horse-drawn batteries.*—At the first command, the cannoneers seated on the chests stand up on the footboards; at the second command, all jump to the ground and take their posts at the double time.

(2) *Truck-drawn batteries.*—At the first command, the cannoneers assume positions from which they can dismount promptly; at the second command, they jump to the ground and take their posts at the double time.

b. If the command is: 1. CANNONEERS, 2. DISMOUNT, the cannoneers execute, at the command DISMOUNT, all that has been prescribed for the commands CANNONEERS, PREPARE TO DISMOUNT and DISMOUNT.

SECTION IV

MOVEMENTS OF THE CARRIAGES BY HAND

■ 12. LIMBERED OR COUPLED.—*a. Horse-drawn batteries.*—(1) *To the front.*—The command is: 1. PIECES (CAISSONS) FORWARD, 2. MARCH, 3. HALT. In each squad at the first command the gunner and No. 1 hasten to the end of the pole; Nos. 2 and 5 to the limber wheels; and Nos. 3 and 4 to the piece (caisson) wheels; higher-numbered cannoneers, if present, to posts as directed by the chief of section; the gunner and the even numbers working on the right side of the carriage, odd numbers on the left. When the piece is to be moved, No. 3 releases the brake. When the caisson is to be moved, No. 4 releases the brake; when the brake is released, Nos. 3 and 4 raise and secure the caisson prop. At the command MARCH, all assist in moving the carriage to the front. At the command HALT, the carriage is stopped. In the case of the piece, No. 4 sets the brakes. In the case of the caisson, Nos. 3 and 4 lower the caisson prop and No. 4 sets the brake. All cannoneers resume their posts.

(2) *To the rear.*—The command is: 1. PIECES (CAISSONS) BACKWARD, 2. MARCH, 3. HALT. Executed as prescribed above, except that at the command MARCH the cannoneers move the carriage to the rear.

b. Truck-drawn batteries.—The carriages are not moved by hand when coupled.

■ 13. UNLIMBERED OR UNCOUPLED.—The command is: 1. PIECES (CAISSONS) FORWARD (BACKWARD), 2. MARCH, 3. HALT.

a. Piece.—(1) *First command.*—At the first command, Nos. 3 and 4 grasp the trail handles, No. 3 on the right and No. 4 on the left; No. 2 grasps the left wheel and No. 5 the right wheel; the gunner and No. 1 place themselves adjacent to their posts, in rear of the axle in moving forward and in front of the axle in moving backward; higher-numbered cannoneers, if present, are employed as directed by the chief of section.

(2) *Second command.*—At the command MARCH, all working together move the piece forward (backward) under the direction of the chief of section. When moving up and down

steep slopes, the gunner assists by alternately setting and releasing the right and left brakes, thus permitting the piece to be pivoted about the locked wheel. At the command **HALT**, they stop the piece, the gunner sets the brakes, and all resume their posts (par. 19).

b. *Caisson*.—Executed as explained for the piece, except that No. 4 releases the caisson brake, and No. 3, when the trail is raised, raises and secures the caisson prop. The gunner and No. 1 are at the footboard when moving forward and at the front of the caisson chest when moving backward, the gunner on the left. At the command **HALT**, No. 3 lowers the caisson prop and No. 4 sets the caisson brake. All take their posts (par. 19).

SECTION V

UNLIMBERING AND LIMBERING

■ 14. **UNLIMBERING**.—*a. Disposition of the carriages*.—(1) *Before unlimbering*.—The piece and its caisson are placed abreast of each other, 2 yards apart, poles pointing in the direction of movement. This formation of the carriages is called a double section. The interval of 2 yards should not be materially changed, otherwise the amount of movement of the carriages by hand is greatly increased. If it is intended to fire to the front, the caisson should be placed on the left of the piece before the command for unlimbering is given; if it is intended to fire to the rear, the caisson should be on the right of the piece; if to the flank, on either side of the piece. In emergencies the carriages may be unlimbered from any formation.

(2) *After unlimbering*.—(a) The adjacent wheels of the piece and the caisson are about 1 yard apart, trails of the piece and the caisson pointing to the rear, the piece on the right and about 1 foot in advance of the caisson.

(b) Normally, the piece is placed slightly in advance to allow for recoil at the first shot, which ordinarily is about 1 foot.

(c) In emergencies the caisson may be placed temporarily on the right of the piece. As this position is not favorable to the service of ammunition, the caisson should be moved to the left of the piece as soon as practicable.

(d) At ceremonies and drills, limbers are posted 25 yards in rear of their carriages, moving to their post at a trot. In active service and in instruction simulating it, limbers are conducted by the first sergeant to a place previously designated by the battery commander, where they are disposed so as to take the best advantage of cover and concealment. If no cover and concealment are available, they are located in rear of either flank, faced toward the front, with wide intervals between them.

b. *To unlimber.*—(1) *General.*—In unlimbering to fire to the front or rear, the caisson establishes the position; in unlimbering to fire to the flank, the element (pieces or caisson) on the side toward which fire is to be directed establishes the position. If the carriages, after unlimbering, have to be moved by hand, each carriage is moved, as prescribed in paragraph 13, in the order designated by the chief of section. If the teams are not hitched, the carriages are unlimbered successively, the one which establishes the position being unlimbered first. Limbers are moved to their position by cannoneers designated by the chief of section.

(2) *To fire to the front.*—The carriages being in double section, the caisson on the left, the command is: **ACTION FRONT**. If marching, the carriages halt at the command or signal. The cannoneers, if mounted, dismount after the carriages have halted.

(a) *The caisson.*—Nos. 3 and 4 hasten to the trail handles; No. 4 unlatches the pintle; Nos. 3 and 4 raise the trail from the pintle, and No. 4 commands or signals **DRIVE ON**. Nos. 3 and 4, assisted by the higher-numbered cannoneers at the wheels, then carry the trail away from the piece, turning the caisson 180°. No. 3, assisted by No. 4, lowers the caisson prop; No. 4 sets the caisson brake; and Nos. 3 and 4 take their posts.

(b) *The piece.*—The gunner and No. 1 hasten to the trail handles; No. 2 grasps the right wheel and places himself so as to be ready to turn the wheel toward the muzzle; No. 5 grasps the left wheel and places himself so as to be ready to turn the wheel toward the trail. The gunner unlatches the pintle and assisted by No. 1 raises the trail from the pintle. The gunner then commands or signals **DRIVE ON**.

The gunner and No. 1 carry the trail away from the caisson, and all the cannoneers working together turn the piece 180°. The gunner causes the piece to be placed beside the caisson (*a* (2) above). No. 1 releases the drawbar lock and turns the drawbar 180°, latching it in the firing position; the gunner and No. 1 then lower the trail to the ground. No. 2 sets the brakes, and all the cannoneers at the piece take their posts (pars. 18c and 19).

(c) *Limbers.*—At the command **DRIVE ON**, the limbers take their prescribed positions. To take post in rear of the carriages, the caisson limber executes a left-about, moves straight to the rear, executes another left-about, and halts so that the heads of the lead horses (or the end of the pole if teams are not hitched) will be 25 yards from the rear of the caisson. The piece limber follows the caisson limber, passes around its rear, and halts so as to be abreast of it and 2 yards to its right.

(3) *To fire to the rear.*—The carriages being in double section, caisson on the right, the command is: **ACTION REAR**. If marching, the carriages halt at the command or signal. The cannoneers, if mounted, dismount after the carriages have halted.

(a) *The caisson.*—Nos. 3 and 4 hasten to the trail handles; No. 4 unlatches the pintle; Nos. 3 and 4 raise the trail from the pintle, and No. 4 commands or signals **DRIVE ON**. No. 3, assisted by No. 4, then lowers the caisson prop; No. 4 sets the brake, and Nos. 3 and 4 take their posts.

(b) *The piece.*—The gunner and No. 1 hasten to the trail handles of the piece; No. 2 grasps the right wheel and No. 5 grasps the left wheel of the piece and both stand ready to assist in such movements of the carriage as may be necessary. The gunner unlatches the pintle and assisted by No. 1 raises the trail from the pintle. The gunner then commands or signals **DRIVE ON**. All working together place the piece beside the caisson (*a* (2) above). No. 1 releases the drawbar lock and turns the drawbar 180°, latching it in the firing position; the gunner and No. 1 then lower the trail to the ground. No. 2 sets the brakes and the cannoneers at the piece take their posts (pars. 18c and 19). Higher-numbered

cannoneers, when present, assist in the movement as directed by the chief of section.

(c) *Limbers*.—At the command or signal **DRIVE ON**, the limbers take their prescribed positions. To take post in rear of the carriages, the caisson limber inclines well to the right, moves to the rear, executes a left-about, and halts so that the heads of the lead horses (or the end of the pole if the teams are not hitched) will be 25 yards from the rear of the caisson. The piece limber follows the caisson limber, passes around its rear, and halts so as to be abreast of it and 2 yards to its right.

(4) *To fire to the flank*.—(a) The carriages being in double section, the caisson on either side of the piece, the command is: **ACTION RIGHT (LEFT)**. The movement is executed according to the principles of **ACTION FRONT** and **ACTION REAR**, with the following modifications. After the carriages are unlimbered, the muzzle of the piece is turned in the direction of fire and the trail of the caisson in the opposite direction; the carriage in rear is run up to its proper position on the line. The carriage on the side toward which fire is to be delivered is first established in position, and then all the cannoneers assist in bringing the carriage in rear up to its proper position (a (2) above).

(b) At the command or signal **DRIVE ON**, the limbers take their prescribed positions. To take post in rear of the carriages, the limber away from the flank toward which fire is to be delivered moves out first, wheels away from the direction of fire, and after having gained sufficient distance to the rear executes an about, and halts so that the heads of the lead horses (or the end of the pole if teams are not hitched) will be 25 yards from the rear of its carriage. The other limber follows and takes post in a similar manner.

■ 15. **LIMBERING**.—a. *To limber front and rear*.—The carriages being in position and in march order (par. 20), the command is: **LIMBER FRONT AND REAR**.

(1) No. 4 releases the caisson brake and hastens to the caisson trail; Nos. 3 and 4 raise the trail, and when the trail is raised No. 3 raises and secures the caisson prop. Nos. 3 and 4 working at the trail, all other cannoneers

assisting, turn the caisson 180°, carrying the trail away from the piece, the gunner and even numbers working on the right and odd numbers on the left. The movement being completed, Nos. 3 and 4 lower the caisson prop, No. 4 sets the caisson brake, and the cannoneers take posts for limbering as follows: The gunner releases the brakes and the gunner and No. 1 then face to the rear at their posts; No. 2 places himself on the right of the gunner and faces to the rear; No. 5 places himself on the left of No. 1 and faces to the rear. Nos. 3 and 4 place themselves with their backs toward the caisson chest close up against the footboard, No. 4 on the right and No. 3 on the left of the trail. Higher-numbered cannoneers take post as directed by the chief of section.

(2) The limbers are brought up as described in Part Two, FM 6-5. As soon as the limber has halted in prolongation of the trail, the gunner and No. 1 spring to the trail handles and raise the trail. Nos. 2 and 5 hasten to the piece wheels and prepare to assist in any movement of the carriage that may be necessary. The gunner and No. 1 raise the trail and place the lunette in the traveling position and over the pintle; the gunner then latches the pintle. The caisson is limbered simultaneously in the same manner; Nos. 3 and 4 handle the trail, No. 4 latching the pintle. Higher-numbered cannoneers assist by working at the wheels of the caisson in any movement of the carriage. As soon as the carriages are limbered, cannoneers take their posts at the carriages limbered (fig. 2).

b. To limber rear.—The carriages being in position and in march order (par. 20), the command is: **LIMBER REAR.**

(1) No. 4 releases the caisson brake; Nos. 3 and 4 raise and secure the caisson prop. All cannoneers working together run the caisson 15 yards straight to the rear of the line of spades. Nos. 3 and 4 lower the caisson prop, No. 4 sets the caisson brake, and all the cannoneers take posts for limbering (*a* (1) above).

(2) The limbers are brought up and the limbering is completed as prescribed in *a* (2) above.

SECTION VI

UNCOUPLING AND COUPLING

■ 16. UNCOUPLING.—*a. General.*—At drills, trucks are posted as directed by the battery commander. In active service and in instruction simulating it, the trucks are conducted by the first sergeant to a place previously designated by the battery commander, where they are disposed so as to take the best advantage of cover and concealment. If no cover and concealment are available, they are located in rear of either flank, faced to the front, with wide intervals between them.

b. To fire to the front.—The command is: **ACTION FRONT**. If marching, the trucks halt at the command or signal. The cannoneers, if mounted, dismount after the trucks have halted.

(1) *The piece.*—The gunner and No. 1 hasten to the wheels nearest their respective posts. Nos. 2 and 5 hasten to the trail handles, No. 2 on the right. No. 2 unlatches the pintle and assisted by No. 5 raises the trail from the pintle; Nos. 2 and 5, assisted by No. 1 at the wheel, swing the piece 180° clockwise. No. 5 releases the drawbar lock and turns the drawbar 180°, latching it in the firing position; Nos. 2 and 5 then lower the trail to the ground. Prior to the turn, the gunner sets the brake on the pivot wheel (the wheel adjacent to the gunner's post) and when the turn is completed sets the other brake. Nos. 3 and 4 unload the ammunition, tools, and accessories from the truck and place them to the left of the piece as directed by the chief of section. When the trail has been lowered to the ground, the gunner and Nos. 1, 2, and 5 assist Nos. 3 and 4 in completing the unloading. When the unloading has been completed, the chief of section commands or signals **DRIVE ON**. The gunner and all cannoneers take their posts (par. 19).

(2) *The trucks.*—At the command **DRIVE ON**, the trucks move out and are conducted by the first sergeant to their previously designated position.

c. To fire to the rear.—The command is: **ACTION REAR**. The movement is executed according to the principles of **ACTION FRONT** except that the piece is not turned after uncoupling.

d. To fire to the flank.—The command is: **ACTION RIGHT (LEFT)**. The movement is executed according to the principles of **ACTION FRONT**, with the following modifications: After uncoupling, the trail is turned 90° away from the direction of fire, and the piece is run forward sufficiently to clear the track made by the truck; articles unloaded from the truck are placed on the ground so as to clear the track made by the truck.

■ 17. **COUPLING.**—*a.* The pieces being in position and in march order, the command is: **COUPLE**. The trucks, under the command of the first sergeant, approach the position from the right (left) flank. As each truck approaches its piece, it turns to the left (right) and halts in prolongation of the trail of the piece.

b. All cannoneers working together under the direction of the chief of section load the tools, accessories, and unexpended ammunition. Then Nos. 2 and 5 hasten to the trail handles. The gunner releases the brakes. The truck, upon signal from the chief of section, is maneuvered backward until the pintle is almost over the lunette. Nos. 2 and 5 raise the trail and place the lunette in the traveling position and over the pintle. No. 2 latches the pintle. All cannoneers take their posts (par. 8).

SECTION VII

PREPARATION FOR ACTION AND MARCH ORDER

■ 18. **TO PREPARE FOR ACTION.**—*a.* The carriages being in position unlimbered or uncoupled, the command is: **PREPARE FOR ACTION**. Duties of individuals are as follows:

(1) *Chief of section.*—(*a*) Supervises the work of the cannoneers.

(*b*) Inspects the matériel, verifies the fact that the recoil mechanism contains the proper amount of oil (TR 1305-75A (now TR 320-95)), and, when the operations have been completed, reports to the executive, "Sir, No. (so and so) in order," or reports any defects which the section cannot remedy without delay.

(2) *Gunner.*—(*a*) Removes the left brake cover and places it on top of the caisson (horse-drawn units), or places it on

the ground outside the left wheel (truck-drawn units), and sets the brakes.

(b) Removes the left trail pin and, assisted by No. 2, sets the pin in the 90° position (or in the 45° position when specifically so ordered by the executive).

(c) Assists Nos. 1, 2, and 5 in removing the gun cover.

(d) Removes the sight bracket cover and places it on the caisson (horse-drawn units), or on the ground outside the left wheel (truck-drawn units).

(e) Releases the sight-bracket traveling lock and raises the sight and bracket to the firing position.

(f) Removes the sight from its case and seats it in the sight bracket.

(g) Engages the sight-bracket gears by means of the throw-out lever; uncovers the sight-bracket leveling bubbles; sets the tilting head at zero, the deflection at zero, and levels the bubbles.

(h) Assists No. 2 in releasing the traveling lock by releasing the pressure on the pin by means of the traversing hand-wheel, and leaves the gun in the center of the traversing arc.

(i) Takes his post.

(3) No. 1.—(a) Removes the right brake cover and places it outside the right wheel.

(b) Removes the right trail pin and, assisted by No. 5, sets the pin in the 90° position (or in the 45° position when specifically so ordered by the executive).

(c) Assists the gunner and Nos. 2 and 5 in removing the gun cover.

(d) Assists No. 2 in unlocking the firing jack from the cradle by elevating the gun slightly.

(e) Removes the range-quadrant cover and places it outside the right wheel.

(f) Sets site 300 and levels the bubble.

(g) Sets range 3,000 and matches the elevation pointers by means of the elevating handwheel.

(h) Removes the breech cover and places it outside the right wheel.

(i) Operates the breech mechanism; sets the safety piece in the firing position.

(j) Examines the breechblock, chamber, and bore, cleaning any parts requiring it; leaves the breech open.

(k) Removes the sponge-and-rammer staff from the traveling position, assembles it, and places it to the right of the piece.

(l) Takes his post.

(4) *No. 2.*—(a) Releases the trail lock and swings the left trail into the 90° position (or into the 45° position when specifically so ordered by the executive), while the gunner sets the trail pin.

(b) Removes the left trail handspike, carries it around the left side of the gun, and places it conveniently beside the firing jack.

(c) Unbuckles the left side gun cover straps and assisted by the gunner and Nos. 1 and 5, removes the gun cover.

(d) Assisted by No. 1 who elevates the piece, and by the gunner who traverses the piece slightly, releases the traveling lock and unlocks the firing jack from the cradle.

(e) Depresses the firing-jack pedal and swings the jack forward and downward, locking it in the firing position.

(f) Using the two trail handspikes, elevates the firing jack.

(g) Sets the traversing control plunger for 90° traverse (or for 45° traverse when specifically so ordered by the executive).

(h) Removes the handspikes from the jack, leaves the right handspike on the right side of the jack where it is convenient for lowering the jack, and returns the left handspike to its firing position in the trail.

(i) Takes his post.

(5) *No. 3, horse-drawn units.*—(a) Assists No. 4 to lower the caisson apron and to raise the caisson door.

(b) Opens the fuze setter, leaving it in the raised position.

(c) Removes the fuze-setter cover, placing it on the caisson.

(d) Sets the fuze-setter scales at corrector 30, range 3,000.

(e) Takes his post.

(6) *No. 3, truck-drawn units.*—(a) Places the fuze setter in position.

(b) Sets the fuze-setter scales at corrector 30, range 3,000

(c) Puts a round of shrapnel in the fuze setter.

(d) Assisted by No. 4, arranges the ammunition and tools in an orderly and convenient manner to the left of the piece.

(e) Takes his post.

(7) *No. 4, horse-drawn units.*—(a) Assists No. 3 to lower the caisson apron and to raise the caisson door.

(b) Takes a fuze box from the caisson rack and places it on the footboard.

(c) Puts a round of shrapnel in the fuze setter.

(d) Takes his post.

(8) *No. 4, truck-drawn units.*—(a) Assists No. 3 to arrange the ammunition and tools.

(b) Takes his post.

(9) *No. 5.*—(a) Swings the right trail into the 90° position (or the 45° position when specifically so ordered by the executive), while No. 1 sets the trail pin.

(b) Removes the right trail handspike, carries it around the right side of the gun, and places it conveniently on the ground to the side of the firing jack.

(c) Unbuckles the right side gun cover straps, and assisted by the gunner and Nos. 1 and 2 removes the gun cover, folds it neatly, and places it on the ground 1 yard to the right of the right piece wheel.

(d) Removes the muzzle cover, and places the muzzle cover, right brake cover, range-quadrant cover, breech cover, and rammer neatly on top of the gun cover. In truck-drawn units, also places the sight-bracket cover and left brake cover on the gun cover.

(e) Removes the aiming stakes and places them beside the sponge-and-rammer staff, or sets out the aiming stakes when so directed by the chief of section.

(f) Distributes waste to the cannoneers.

(g) Takes his post.

b. The limbered (coupled) carriages may be partially prepared for action before reaching the firing position. The duties of the cannoneers are the same as when the carriages are unlimbered (uncoupled), but only such operations as are practicable are carried out before the carriages are unlimbered (uncoupled). Immediately after establishing the car-

riages in position, preparation for action is completed without command, and the cannoneers take their posts for firing the piece.

c. If PREPARE FOR ACTION has not been ordered before the carriages are established in the firing position, the command habitually is given by the chief of section as soon as the carriages have been unlimbered (uncoupled). In case this is not desired, the caution, "Do not prepare for action," must be given.

■ 19. POSTS OF THE CANNONEERS, CARRIAGES UNLIMBERED (UNCOUPLED).—*a.* The carriages having been unlimbered (uncoupled), posts are taken as follows:

(1) *Chief of section.*—The chief of section goes where he can control the service of the piece, hear commands, and perform his duties effectively. A convenient post is at the end of the trail on the side opposite the executive.

(2) *Gunner.*—Immediately to the left of the breech, behind the axle (inside or outside the trail, depending upon the traverse of the piece).

(3) *No. 1.*—Immediately to the right of the breech, behind the axle (inside or outside the trail, depending upon the traverse of the piece).

(4) *No. 2.*—Two feet in rear of the gunner, covering him.

(5) *No. 3, horse-drawn units.*—Two feet in rear of the caisson chest, on the right of the caisson trail.

(6) *No. 3, truck-drawn units.*—Two feet to the left of and opposite the rear of the left piece wheel.

(7) *No. 4.*—Two feet in rear of No. 3, covering him.

(8) *No. 5, horse-drawn units.*—Two feet in rear of the caisson chest, on the left of the caisson trail.

(9) *No. 5, truck-drawn units.*—Two feet to the left of No. 4.

b. At drill all stand at attention at their posts (fig. 5), facing the front. In firing and in combat, minor modifications of these posts are required for the more efficient performance of the duties in the service of the piece and to secure the protection afforded by the matériel. Higher-numbered cannoneers, if present, take posts as prescribed by the chief of section.

c. In order to exercise the cannoneers in all the duties connected with the service of the piece and to lend variety to the drill, the posts of individual cannoneers should be changed frequently.

■ 20. MARCH ORDER.—*a. Duties of individuals.*—The carriages being unlimbered (uncoupled) and prepared for action, to resume the order for marching, the command is: MARCH ORDER. Duties of individuals are as follows:

(1) *Chief of section.*—(a) Supervises the work of the cannoneers.

(b) Inspects the matériel; *makes sure that the piece is not left loaded* and that the traveling locks are set for traveling;

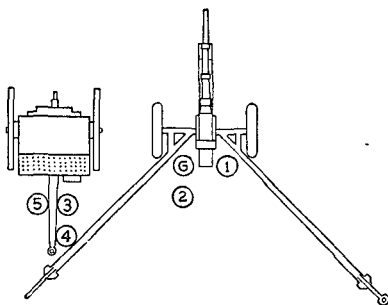

FIGURE 5.—Posts of the cannoneers, carriages unlimbered, horse-drawn unit.

and, when the operations have been completed, reports to the executive, "Sir, No. (so and so) in order," or reports any defects which the section cannot remedy without delay.

(2) *Gunner.*—(a) Sets the tilting head and deflection at zero and closes the covers on the sight-bracket leveling bubbles.

(b) Removes the sight from its bracket, returns it to its case, and locks the case.

(c) Disengages the sight-bracket gears and turns the sight bracket to the traveling position.

(d) Engages the sight-bracket lock in the traveling position.

(e) Traverses the piece to the center of the traversing arc, assisting No. 2 in locking the firing jacket in the traveling position.

(f) Traverses slightly right and left, while No. 2 secures the traveling lock.

(g) Withdraws the left trail pin and puts it in its traveling position while No. 2 closes the trail.

(h) Replaces the sight-bracket and left-brake covers, which have been handed him by No. 2 (horse-drawn units) or No. 5 (truck-drawn units), on the sight bracket and left brake (after first releasing the brakes).

(i) Assists Nos. 1, 2, and 5 in replacing the gun cover on the gun.

(j) Takes his post.

(3) No. 1.—(a) Sets the angle of site at 300, and levels the angle-of-site bubble.

(b) Closes the cover of the angle-of-site bubble.

(c) Closes the breech and sets the safety piece in the traveling position.

(d) Unscrews the sponge-and-rammer staff, and places it in the traveling position.

(e) Assists No. 2 in locking the firing jack in its traveling position by depressing the piece.

(f) Withdraws the right trail pin and puts it in its traveling position while No. 5 closes the trail.

(g) Replaces the range-quadrant, breech, and right brake covers, which have been handed to him by No. 5.

(h) Assists the gunner and Nos. 2 and 5 in replacing the gun cover.

(i) Takes his post.

(4) No. 2.—(a) Takes the right trail handspike from its position at the side of the jack and inserts it into the jack.

(b) Releases the firing jack, permitting the piece to drop on its wheels, and hands the right trail handspike to No. 5.

(c) Swings the jack forward and upward, and, assisted by the gunner and No. 1 on the traversing and elevating handwheels, locks the jack in the traveling position.

(d) Assisted by the gunner on the traversing handwheel, secures the traveling lock in its traveling position.

(e) In horse-drawn units only, hands the sight-bracket and left-brake covers to the gunner.

(f) Removes the left trail handspike and secures it in its traveling position.

(g) Raises the left trail and moves it to its closed position while the gunner removes the left trail pin.

(h) Locks the trails in the traveling position.

(i) Assists the gunner and Nos. 1 and 5 in replacing the gun cover on the gun.

(j) Takes his post.

(5) *No. 3, horse-drawn units.*—(a) Sees that any fuzes which have been set are set back at safe.

(b) Sets the fuze setter at corrector 30, range 3,000.

(c) Returns unused fuzes to the fuze box.

(d) Replaces the fuze-setter cover.

(e) Secures the fuze setter in the traveling position.

(f) Assists No. 4 to lower and secure the caisson door, and to raise and secure the caisson apron.

(g) Takes his post.

(6) *No. 3, truck-drawn units.*—(a) Sees that any fuzes which have been set are set back at safe.

(b) Sets the fuze setter at corrector 30, range 3,000.

(c) Returns unused fuzes to the fuze box.

(d) Replaces the fuze setter in the box.

(e) Assisted by No. 4, prepares ammunition and tools for loading into the truck. *He will assure himself that all fuzes have been set at safe.*

(f) Takes his post.

(7) *No. 4, horse-drawn units.*—(a) Assists No. 3 in setting fuzes back at safe.

(b) Replaces or otherwise disposes of unused ammunition. *Before replacing any round in the caisson chest, he will assure himself that the fuze is set at safe.*

(c) Runs around the left of the caisson and replaces the fuze box in the caisson rack.

(d) Assists No. 3 to lower and secure the caisson door, and to raise and secure the caisson apron.

(e) Takes his post.

(8) *No. 4, truck-drawn units.*—(a) Assists No. 3 to prepare ammunition and tools for loading into the truck.

(b) Takes his post.

(9) No. 5.—(a) Replaces the muzzle cover.

(b) Takes the right trail handspike from No. 2, passes around the right side of the piece, handing the breech, range-quadrant, and right brake covers to No. 1 on his way, and secures the right trail handspike in its traveling position; in truck-drawn units, hands the sight-bracket cover and left brake cover to the gunner.

(c) Secures the aiming stakes.

(d) Raises the right trail and moves it to its closed position while No. 1 removes the right trail pin.

(e) Secures the gun cover and assists the gunner and Nos. 1 and 2 in replacing it on the gun.

(f) Takes his post.

b. To resume fire in another position.—(1) If it is intended to resume firing shortly, but in another position, so that the limbering (coupling) of the pieces is necessitated, the command MARCH ORDER is not given. In this case, at the command for limbering (coupling), only such of the operations incident to march order are performed as are necessary for the movement of the piece (and caisson) and for the care and security of the equipment.

(2) If the command MARCH ORDER is given while the pieces are limbered (coupled), the operations pertaining to march order are completed as described above.

SECTION VIII

DUTIES IN FIRING

■ 21. GENERAL.—*a.* In general, the duties in firing are as follows:

(1) The chief of section is responsible that all duties are properly performed, all commands executed, and all safety precautions observed.

(2) The gunner sets the announced deflection, lays for direction, and refers the piece.

(3) No. 1 sets the announced site and range, opens and closes the breech, lays for elevation, and fires the piece.

(4) No. 2 loads the piece.

(5) No. 3 operates the fuze setter and screws fuzes in shell.

(6) No. 4 prepares ammunition and passes rounds to No. 2 for loading; in time fire he keeps rounds in the fuze setter and sets the fuze.

(7) No. 5 prepares ammunition for firing, and in direct laying at moving targets levels the angle-of-site bubble and sets the range.

b. The duties of the gunner and Nos. 1 and 2 are mutually dependent. The same is true of Nos. 3, 4, and 5.

■ 22. CHIEF OF SECTION.—*a. Enumeration of duties.*—(1) Assisted by No. 1, to lay for elevation when the gunner's quadrant is used.

(2) To measure the elevation.

(3) (a) To measure the minimum quadrant elevation.

(b) To measure the minimum range.

(4) To indicate to the gunner the aiming point, the referring point, or the target.

(5) To follow fire commands.

(6) To indicate when the piece is ready to fire.

(7) To give the command to fire, except when firing at moving targets with direct laying.

(8) To report errors and other unusual incidents of fire to the executive.

(9) To conduct prearranged fire schedules.

(10) To record basic data.

(11) To observe and check frequently the functioning of the matériel.

(12) To assign duties when firing with reduced personnel.

(13) To conduct the fire of his piece on a moving target, when so ordered by the executive.

b. Detailed description of certain duties.—(1) *To lay for elevation when the gunner's quadrant is used.*—(a) The chief of section is first taught to read settings on the gunner's quadrant and then to set the elevations announced. To set an elevation on the gunner's quadrant, for example, 361.8 mils, the chief of section sets the upper edge of the head of the index arm opposite the 360 mark of the graduated arc on the quadrant frame and slides the slide level along the index

arm until its index is opposite the 1.8 mark of the scale on the index arm. Care must be taken in setting the slide to use the scale on the index arm which is on the same side of the quadrant as the graduated arc on the frame which was used in setting the index arm at 360 mils. After the slide has been set, the clamp is tightened just sufficiently to hold the slide in place.

(b) The command **QUADRANT (SO MUCH)** indicates that the gunner's quadrant is to be used.

(c) The announced elevation having been set on the gunner's quadrant, the piece loaded, and the breechblock closed, the chief of section places the quadrant on the quadrant seat on the breech hoop, with the words "line of fire" at the bottom and the arrow pointing toward the muzzle. The chief of section must be sure to use the arrow which appears on the same side of the quadrant as the scale which he is using. He stands squarely opposite the side of the quadrant and holds it firmly on the quadrant seat, parallel to the axis of the bore. It is important that he take the same position and hold the quadrant in the same manner for each subsequent setting, so that the quadrant bubble will in each case be viewed from the same angle.

(d) No. 1 operates the elevating handwheel until the quadrant bubble is centered, making sure that his last movement is in the direction in which it is most difficult to turn the handwheel. (Up to about 400 mils' elevation or 7,500 yards' range setting, this is in the direction of decreasing elevation; otherwise in the direction of increasing elevation.) The chief of section warns No. 1 when the bubble is approaching the center, in order that the final centering may be performed accurately.

(2) *To measure the elevation.*—At the command **MEASURE THE ELEVATION**, the piece having been laid, the chief of section sets the slide level of the index arm of the gunner's quadrant at zero and places the quadrant on the quadrant seat as in laying for elevation ((1) above). He then moves the index arm until the bubble passes to the end of the vial away from the hinge of the index arm. He then slowly lowers the index arm until the bubble just passes to the end of the vial toward the hinge. He then allows the index arm

to engage the arc and slides the level along the index arm until the bubble is accurately centered. He then removes the quadrant and reads and announces the elevation thus set, for example, "Elevation, No. (so and so), (so much)."

(3) *To measure the minimum elevation or minimum range.*

(a) 1. *Elevation.*—The command is: **MEASURE THE MINIMUM ELEVATION.** The chief of section, sighting along the lowest element of the bore, causes No. 1 to operate the elevating mechanism until the line of sight just clears the crest. He then measures the quadrant elevation as described in (2) above and reports the angle read from the gunner's quadrant to the executive, thus, "Minimum elevation, No. (so and so), (so much)."

2. *Range.*—The command is: **MEASURE THE MINIMUM RANGE, SITE (SO MUCH).** The chief of section causes No. 1 to set the site announced and to center the angle-of-site bubble. Sighting along the lowest element of the bore, he then causes No. 1 to operate the elevating handwheel until the line of sight just clears the crest. No. 1 then matches the elevation pointers by operating the range drum and reads the range setting. The chief of section reports this range as the minimum range to the executive, thus, "Minimum range, No. (so and so), (so much), site (so much)."

(b) When the executive announces the corrected minimum elevation or the corrected minimum range and site, the chief of section records it in a notebook and causes the gunner to chalk it on a convenient place on the carriage.

(4) *To indicate to the gunner the aiming point, the referring point, or the target.*—Whenever an aiming point, a referring point, or a target has been designated by the executive, the chief of section will make sure that he has properly identified the point in question. He will then indicate it to the gunner. If there is any possibility of misunderstanding, the chief of section will turn the sight until the horizontal and vertical hairs are on the point designated.

(5) *To follow fire commands.*—The chief of section will follow the fire commands mentally. He will not repeat the commands, but will be prepared to give any element of the last command to any cannoneer who has failed to hear it.

(6) *To indicate when the piece is ready to fire.*—When arm signals between the chief of section and the executive can be observed, the chief of section will extend his right arm vertically as soon as the gunner has called "Ready," as a signal to indicate that the piece is ready to fire. When arm signals cannot be observed, the chief of section reports orally to the executive, "No. (so and so) ready."

(7) *To give the command to fire.*—When No. 1 can see arm signals made by the chief of section, the chief of section will give the command to fire by dropping his right arm sharply to his side. When arm signals cannot be used, the command NO. (SO AND SO) FIRE will be given orally. *The chief of section will not give the signal or command to fire until all the cannoneers are in their proper places. He will require the cannoneers to stand clear of the piece for the first round.*

(8) *To report errors and other unusual incidents of fire to the executive.*—If for any reason the piece cannot be fired, the chief of section will report promptly to the executive that fact and the reason therefor; for example, "No. (so and so) out, misfire." Whenever it is discovered that the piece has been fired with an error in laying, the chief of section will report that fact at once; for example, "No. (so and so) fired with incorrect deflection." Whenever the gunner reports that the aiming stakes are out of alinement with the sight, the chief of section will report that fact and request instructions (par. 32). Likewise, other unusual incidents that affects the service of the piece are promptly reported by the chief of section.

(9) *To conduct prearranged fire schedules.*—Whenever the execution of prearranged fires is ordered, the chief of section will conduct the fire of his section in strict conformity to the schedule prescribed.

(10) *To record basic data.*—Data of a semipermanent nature will be recorded in a notebook by the chief of section. This includes such data as minimum elevations; base deflections, including aiming points used; prearranged fires when

prepared schedules are not furnished; safety limits in elevation and deflection; number of rounds fired, with the date and hour, and calibration corrections when appropriate.

(11) *To observe and check the functioning of the matériel.*—The functioning of all parts of the matériel will be observed closely during firing. Before the piece is fired, the chief of section verifies the fact that the recoil mechanism contains the proper amount of oil and thereafter carefully observes the functioning of the recoil system. Any evidence of trouble (par. 47) is reported promptly to the executive.

(12) *To assign duties when firing with reduced personnel.*—Whenever the personnel of the section serving the piece is temporarily reduced in numbers below that indicated in this manual, the chief of section will make such redistribution of duties as will best facilitate the service of the piece.

(13) *During direct laying on a moving target, to conduct the fire of his piece when so ordered by the executive.*—(a) *To announce an initial lead.*—The chief of section observes the target, estimates its lateral speed, and, based thereon, the lead in mils, and announces the lead to the gunner; for example, LEAD RIGHT (LEFT) (SO MUCH). The necessary lead at any range may be taken as one mil for each mile-per-hour lateral speed of the target. Another method is to measure in mils the lateral movement of the target while counting four in quick-time cadence (2 seconds); this will give the proper lead for a range of 1,000 yards. The count is decreased proportionately for ranges less than 1,000 yards, increased proportionately for ranges greater than 1,000 yards. If the lead is observed to be in error, or if the speed or direction of movement changes during firing, a new lead is announced.

(b) *To announce an initial site.*—The chief of section estimates the angle of site of the target and announces it to No. 1.

(c) *To announce an initial range.*—The chief of section estimates the initial range of the target and announces it to No. 5. During the firing he announces range changes as appropriate.

■ 23. GUNNER.—a. *Enumeration of duties.*—(1) (a) To center the bubbles on the sight mount.

(b) To set or change the deflection.

(c) To apply the deflection difference.

(d) To lay for direction.

(e) To call "Ready."

(f) To refer the piece.

(g) To record base deflection.

(h) To measure a deflection.

(i) To take and maintain an announced lead in tracking the target during direct laying on a moving target.

(j) To give the command to fire, during direct laying on a moving target.

(2) For indirect laying or direct laying on a stationary target, the gunner performs the duties prescribed in (1) (a), (b), (c), (d), and (e) above.

(3) For direct laying on a moving target, the gunner performs the duties prescribed in (1) (a), (i), and (j) above.

(4) When directed, the gunner performs the duties prescribed in (1) (f), (g), and (h) above.

b. Detailed description of certain duties.—(1) *To set or change the deflection.*—(a) *To set the deflection.*—The gunner is first taught to read deflections set on the sight and then to set the deflections announced. At the command, for example, DEFLECTION 1,885, the gunner first sets the zero of the azimuth micrometer opposite the fixed azimuth index, if it is not already so set. He then pushes the throw-out lever with his left hand and with his right hand turns the rotating head until the hundreds' graduation (18 in this case) is opposite the azimuth-circle index. He then releases the throw-out lever and, grasping the azimuth-worm knob with his left hand with the thumb on top, turns the azimuth-worm knob to the left until the micrometer index is opposite the graduation 85 of the counterclockwise graduations on the azimuth micrometer. The line of sight will then make a horizontal angle of 1,885 mils with the axis of the bore. The azimuth micrometer is then turned until its zero graduation is opposite the micrometer index. Any movement of the azimuth micrometer does not change a deflection previously set.

(b) *To change the deflection.*—The gunner should be trained always to grasp the azimuth-worm knob with his left thumb on top, as the command for changing the deflection then will indicate the direction in which he should move his

thumb in turning the azimuth-worm knob. He also should be taught that turning the azimuth-worm knob to the right decreases the deflection set on the sight and results in moving the muzzle to the right when the piece is laid with the new deflection. Similarly, turning the azimuth-worm knob to the left increases the deflection and results in moving the muzzle to the left when the piece is laid. The deflection having been set at 1,885 mils, if a subsequent command be, for example, RIGHT 65, the gunner turns the azimuth-worm knob by moving his thumb to the right until the micrometer index has moved from zero to 65 on the clockwise graduations of the azimuth micrometer. As turning the azimuth-worm knob to the right decreases the deflection, the resulting deflection will be 1,820 mils. The azimuth micrometer is then reset with its zero opposite the micrometer index. Should the command be LEFT (SO MUCH), the deflection setting is changed in a similar manner, except that the gunner moves his thumb to the left and follows the counterclockwise graduations of the azimuth micrometer.

(2) *To apply the deflection difference.*—(a) The command is: ON NO. (SO AND SO) OPEN (CLOSE) (SO MUCH). The gunner of the piece indicated in the command does not change the deflection set on his sight. Each of the other gunners changes his sight setting by the number of mils specified in the command if his piece is next in line to the piece indicated; by twice this number of mils if his piece is second in line from the piece indicated; by three times this number of mils if his piece is third in line from the piece indicated.

(b) If the command is, for example, ON NO. 1 OPEN 5, the gunner on No. 1 makes no change; the gunner on No. 2 turns the azimuth-worm knob by moving his thumb to the left, *away from the piece indicated in the command*, and sets off 5 mils once; the gunner on No. 3 turns the azimuth-worm knob in a similar manner, except that he sets off 5 mils twice, a total of 10 mils; the gunner on No. 4 also turns his azimuth-worm knob in a similar manner, except that he sets off 5 mils three times, a total of 15 mils.

(c) Should the command be, for example, ON NO. 3 CLOSE 10, the gunner on No. 1 turns the azimuth-worm knob by moving his thumb to the left, *toward the piece indicated in the com-*

mand, and sets off 10 mils twice, or a total of 20 mils; the gunner on No. 2 turns his azimuth-worm knob in a similar manner, except that he sets off 10 mils once; the gunner on No. 3 makes no change; the gunner on No. 4 turns his azimuth-worm knob by moving his thumb to the right and sets off 10 mils once.

(*d*) It should be noted that, in making the deflection changes involved in applying the deflection difference, each gunner turns the azimuth-worm knob by moving his thumb away from the piece indicated if the command is *OPEN*, and toward the piece indicated if the command is *CLOSE*; also that the muzzles of the pieces will be moved in similar directions when the pieces are laid after the deflection difference has been set.

(*e*) In training gunners to apply the deflection difference, it will be found advantageous to teach them to use the sight as a mechanical adding machine. For example, if the command is *ON NO. 1 OPEN 8*, the gunner on No. 4 first sets off 8 mils, then after an imperceptible pause another 8 mils, and so on until he has set off 8 mils three times. This method requires no mental arithmetic.

(*f*) When a deflection change and a deflection difference are announced at the same time, for example, *RIGHT 30, ON NO. 1 CLOSE 5*, both of which affect the gunner's piece, he will first set off the deflection change and then apply the deflection difference.

(*g*) In the methods described above, it is implied that the gunner resets the azimuth micrometer with its zero opposite the micrometer index each time the azimuth-worm knob has been turned. By so doing, each change in the deflection setting is made by starting with the micrometer index at zero. This facilitates setting off the tens and units on the azimuth-micrometer scales. It is important that the gunner before turning the azimuth-worm knob verify the setting of the azimuth micrometer to make sure that its zero coincides with the micrometer index.

(*h*) Another method is authorized as follows: The zero of the azimuth micrometer is left opposite the fixed azimuth index at all times. Deflection changes are made in the proper direction by turning the micrometer index through the re-

quired number of graduations, the only difference being that the movement of the index does not always start at zero.

(i) Irrespective of which method is used, all gunners in a battery should be required to use the same method.

(3) *To lay for direction.*—(a) *Indirect laying.*—The deflection having been set, the gunner brings the vertical hair of the panoramic sight on the aiming point by traversing the piece. If the amount of movement necessary is greater than can be obtained by traversing, the trails must be shifted. To shift the trails, the gunner commands or signals MUZZLE RIGHT (LEFT). No. 2 on the left trail handspike and No. 5 on the drawbar on the right trail then shift the trails so that the muzzle moves in the indicated direction until commanded or signaled to stop by the gunner. The gunner then completes the laying by bringing the vertical hair of the sight on the aiming point.

(b) *Direct laying on a stationary target.*—The deflection having been set, the gunner traverses the piece by means of the traversing handwheel until the vertical hair of the sight is on his part of the target. If the amount of movement necessary to lay on the target is greater than can be obtained by traversing, the trails must be shifted ((a) above).

(c) *Direct laying on a moving target.*—See (8) below.

(d) *Procedure to insure accuracy.*—To take up lost motion, the final movement of the traversing handwheel should be such as to cause the vertical hair of the sight to approach the aiming point from the left. The gunner should habitually rest the weight of his shoulder against the shoulder guard in laying the piece for direction and keep in this position until the piece has been fired, to aid in taking up lost motion. The gunner should habitually lay with the vertical hair of the sight on exactly the same portion of the aiming point or target for each round.

(4) *To call "Ready."*—The piece having been laid for direction, and No. 1 having called "Set," the gunner verifies the laying, moves his head clear of the sight, and calls "Ready" to indicate that the piece is ready to be fired.

(5) *To refer the piece.*—The piece having been laid for direction, to refer the piece, the command is: 1. AIMING POINT (so AND so), 2. REFER. Without disturbing the laying of

the piece, the gunner brings the vertical hair of the sight on the new aiming point (referring point). He then reads and announces the deflection thus set and records the deflection and the referring point upon a convenient part of the carriage. Two referring points usually are used, one for day and another for night. A referring point should be at least 50 yards from the sight, preferably to the rear. Frequently it will be necessary to use the aiming stakes as referring points, particularly for night use.

(6) *To record base deflection.*—At the command **RECORD BASE DEFLECTION**, the gunner records the deflection set on his sight upon some convenient part of the carriage or upon a data board (par. 40).

(7) *To measure a deflection.*—The command is: 1. **AIMING POINT (SO AND SO)**, 2. **MEASURE THE DEFLECTION**. The piece having been established in direction, the gunner turns the sight until the vertical hair is on the aiming point. He then reads and announces the deflection.

(8) *For direct laying on a moving target, to take and maintain an announced lead.*—The command is: **LEAD RIGHT (LEFT) (SO MUCH)**. The gunner sets his sight at zero and tracks the target with the traversing handwheel, keeping the vertical hair of the sight ahead of the target by the announced lead, measured in the reticule scale of the sight.

(9) *For direct laying on a moving target, to give the command to fire.*—In direct laying, having heard No. 1 announce "Set," and having the announced lead maintained on the target, the gunner commands: **FIRE**.

■ 24. No. 1.—*a. Enumeration of duties.*—(1) (a) To set the angle of site.

(b) To level the angle-of-site bubble.

(c) To set the range.

(d) To set the elevation.

(e) To lay for elevation.

(f) To open and close the breech.

(g) To call "Set."

(h) To fire the piece.

(i) To use the rammer.

(2) For indirect laying or direct laying on a stationary target without the gunner's quadrant, No. 1 performs the duties prescribed in (1) (a), (b), (c) or (d), (e), (f), (g), and (h) above.

(3) For indirect laying with the gunner's quadrant, No. 1 performs the duties prescribed in (1) (e), (f), (g), and (h) above.

(4) For direct laying on a moving target, No. 1 performs the duties prescribed in (1) (a), (e), (f), (g), and (h) above.

b. Detailed description of certain duties.—(1) *To set the angle of site.*—No. 1 is first taught to read angles of site on the angle-of-site scale, and then to set angles of site. To set an angle of site, No. 1 grasps the angle-of-site worm knob in his right hand and turns it until the announced reading is shown. The angle of site is indicated by a scale graduated in hundreds of mils from zero to 6, and a micrometer scale graduated in mils, 300 being the horizontal. No. 1 first sets the index in the proper section of the scale in hundreds of mils and then sets the units on the micrometer scale. The last motion in setting the angle of site should be in the direction of increasing site.

(2) *To level the angle-of-site bubble.*—Having set the announced angle of site, No. 1 grasps the leveling-worm knob in his right hand and levels the angle-of-site bubble, making sure that the last movement of the bubble is from front to rear.

(3) *To set the range.*—No. 1 is first taught to read ranges on the range-quadrant range drum, and then to set ranges. To set a range, No. 1 grasps the range-drum knob in his right hand and turns it until the announced range is opposite the index, making sure that the last movement is in the direction of increasing range.

(4) *To set the elevation.*—The elevation may be set on the range-quadrant elevation scale. No. 1 is first taught to read elevations on the elevation scale and then to set elevations. To set an elevation of zero or above, No. 1 sets the angle of site at 300 (or at an announced site) and levels the bubble ((1) and (2) above). He then sets the announced elevation on the elevation scale. The elevation is indicated by a scale graduated in hundreds of mils from zero to 800 and a mi-

rometer scale graduated from zero to 100 mils. No. 1 grasps the range drum knob in his right hand and turns it until the announced elevation is shown, making sure that his last movement is in the direction of increasing elevation. To set off an elevation of less than zero mils, No. 1 sets the elevation scale at zero, subtracts the announced negative elevation from 300, sets the resultant figure on the angle-of-site scale ((1) above), and centers the angle-of-site bubble ((2) above).

(5) *To lay for elevation.*—(a) *Without the gunner's quadrant.*—No. 1, having performed the duties described in (1), (2), and (3) or (4) above, grasps the elevating handwheel in his left hand and matches the range-quadrant pointers, making sure that his last movement is in the direction in which it is most difficult to turn the handwheel. (Up to about 400 mils elevation or 7,500 yards range setting, this is in the direction of decreasing elevation, otherwise in the direction of increasing elevation.)

(b) *With the gunner's quadrant.*—See paragraph 22.

(6) *To open and close the breech.*—(a) *To open the breech.*—For the first round, No. 1 cocks the latch by pushing the plunger in the handle forward; the recoil of the gun automatically cocks the latch for subsequent rounds. No. 1 then grasps the operating handle with both hands, palms down, with the fingers fully closed around it, and moves the handle upward so as to rotate the breechblock as far as it will go. The movement should be completed with a snap of the forearms and wrists so as to eject the cartridge case fully. *As soon as the breech is open, No. 1 looks through the bore to see that it is clear.* In firing, he opens the breech as the gun returns to battery. In this operation he must be careful to close his fingers fully on the operating handle to avoid having them caught between the breech hoop and the end of the cradle. Should his fingers be caught in this manner, the tube must be uncoupled and moved to the rear, and if caught in such a manner that the breechblock cannot be rotated, the lug of the safety bolt must be sheared off (TR 1305-75A (now TR 320-95)).

(b) *To close the breech.*—No. 1 grasps the operating handle with his left hand, moves the handle downward, and drops his hand to his side.

(c) *Opening and closing the breech.*—When No. 1 understands the functioning of the breech mechanism, Nos. 1 and 2 are instructed in loading and unloading the piece. The breech being open, No. 1 rests his left hand, palm open, lightly on the operating handle ready to close the breech. As the round is inserted and pushed home by No. 2, it causes a slight rotation of the breechblock which No. 1 immediately takes up by grasping the operating handle with his left hand and continues, closing the breech. If No. 1 resists the impulse of rotation, or starts to close the breech before the round is fully inserted, the round will rebound and prevent closing the breech. Whenever this occurs, No. 1, *not* No. 2, will reseal the round. For drill purposes in opening and closing the breech, the drill wedge, a small wooden wedge made locally, is inserted between the pawl and the plunger lug. The drill wedge is removed before firing service ammunition. The drill projectiles used for this instruction must be in good condition. To avoid damaging the projectiles when they are ejected, a mat or similar cushion should be placed at the point where they fall. If full-weight drill projectiles are used, No. 2, standing at the breech, receives the ejected round in both hands.

(7) *To call "Set."*—No. 1, when the piece has been loaded, the breech closed, and the piece laid for elevation, calls "Set."

(8) *To fire the piece.*—At the chief of section's command NO. (SO AND SO) FIRE, or, for direct laying on a moving target, at the gunner's command FIRE, No. 1 grasps the handle of the lanyard with the left hand, without raising his hand pulls it to the rear and slightly downward as far as possible, and quickly releases it. *Under no circumstances will No. 1 grasp the lanyard until the gunner calls "Ready" (or "Fire").* If the chief of section gives the command STAND CLEAR, No. 1 steps clear of the wheel and, at the command or signal FIRE, leans forward, grasps the handle of the lanyard, and fires the piece. The chief of section may caution, "With the long lanyard." In this case No. 1 attaches the long lanyard to the firing link, steps clear, and fires as previously described.

No. 1 detaches the long lanyard immediately after each round is fired. *In case of a misfire, the instructions contained in paragraph 38 will be followed.*

(9) *To use the rammer.*—*The sponge and rammer will be handled by No. 1 only.* The rammer is used to extract unfired rounds or cartridge cases which cannot be ejected by the extractor. To extract a cartridge case which cannot be ejected by the extractor, the bottom of the inside of the case is tapped lightly until it is loosened and can be pushed out of the chamber. No. 2, standing at the breech, receives the cartridge case in both hands. To extract an unfired round, the procedure prescribed in paragraph 37 will be followed.

■ 25. No. 2.—*a. Enumeration of duties.*—(1) To load the piece.

(2) In volley fire, to call out the number of the round.

(3) When necessary, to assist No. 5 in shifting the trails.

b. Detailed description of certain duties.—(1) *To load the piece.*—To receive the round, No. 2 steps with his left foot toward No. 4 and grasps the round with his right hand at the base of the cartridge case and his left hand in rear of the ogive. He then resumes his position facing the gunner and inserts the round in the breech, removing his left hand. He pushes the round home with his right hand. When about one third of the cartridge case still extends beyond the breech face, he gives the round a final impetus until his open hand comes in contact with the breech, and then, continuing the motion, he rotates his hand upward and to the left, clearing the breech. *No. 2 will be particularly careful to avoid striking the fuze against any portion of the matériel. To prevent premature bursts caused by projectiles being struck on the fuze by the piece in recoil, a round to be loaded will be held well out of the path of the recoil of the gun until the latter is again in battery.* (AR 750-10.)

(2) *To call out the number of the round.*—To insure that the correct number of rounds is fired in volley fire, No. 2 calls out the range and the number of the round as he loads the piece; and, as he loads the last round, adds "Last round." For example, when two rounds are to be fired at 2,800, he

calls out, "2,800 one; 2,800 two, last round." He should not speak louder than necessary to insure his being heard by the members of his own gun squad.

(3) *When necessary, to assist No. 5 in shifting the trails.*—No. 2 goes to the handspike on the left trail, while No. 5 handles the right trail, and shifts the trail right or left as directed by the gunner. The command is: MUZZLE RIGHT (LEFT), and the trail is shifted in the opposite direction so that the muzzle is swung in the direction indicated. At the gunner's signal, Nos. 2 and 5 lower the trails to the ground.

■ 26. No. 3.—*a. Enumeration of duties.*—(1) To set the fuze setter.

(2) To set fuzes.

(3) To fuze shell.

(4) To remove fuzes from shell.

b. Detailed description of certain duties.—(1) *To set the fuze setter.*—(a) The series of fire commands for initially opening fire with time-fuzed projectiles will contain the data to be set on the fuze setter. These commands are, for example, CORRECTOR 28, 3,600. For subsequent rounds, the corrector is increased (decreased) at the command UP (DOWN) (SO MUCH).

(b) No. 3 is first taught to read data set on the fuze setter and then to set data announced. To set data on the bracket fuze setter, No. 3 turns the corrector-worm knob with his right hand until the graduation on the corrector scale, corresponding to the corrector announced, is opposite the index. He then turns the range-worm crank until the graduation on the range scale, corresponding to the range announced, is opposite the fixed index.

(c) To set data on the hand fuze setter, No. 3 turns the corrector-worm knob until the graduated line on the corrector scale, corresponding to the corrector announced, is in coincidence with the index engraved on the rim of the case. He then turns the knob on the range-scale worm until the graduation on the range scale, corresponding to the range announced, is in coincidence with the index on the index bar.

(d) If the range to be set on the fuze setter differs from that to be set on the piece, the command FUZE RANGE (SO

MUCH) will be given. In this case No. 3 sets the fuze range on the fuze setter, disregarding the range announced for the piece.

(e) If the command PERCUSSION is given, the fuze setter is not used. However, No. 3 keeps the range scale of the fuze setter set according to the ranges announced. He is thus ready to pass to time fire as soon as a corrector is announced.

(f) To insure accuracy in setting the scales of the fuze setter, it is necessary that No. 3 look squarely at the scales and their indexes. To take up lost motion, the final movement of the scales should always be in a counterclockwise direction.

(g) The fuze data having been set on the fuze setter, No. 3 calls "Cut" as a signal to No. 4 to set the fuze.

(2) *To set fuzes.*—No. 3 sets fuzes only when the hand fuze setter is used. The fuze data having been set on the fuze setter as indicated above, to set the fuze, the projectile being held by No. 4, No. 3 places the fuze setter over the fuze. The fuze setter is then turned in the direction indicated by the arrow on the fuze-setter case until the slot in the range-ring carrier engages the pin on the graduated time-train ring of the fuze. The guide plate and the range-ring carrier will then bear firmly on the fuze. No. 3 continues to turn the fuze setter in the direction indicated until the stop pin attached to the corrector-scale support engages with the fixed stop pin on the fuze and prevents further motion. When the fuze has been properly set, the pointer which is attached to the top of the corrector scale will register with the graduated line on the closing cap of the fuze. The fuze setter is then removed.

(3) *To fuze shell.*—At the command SHELL, No. 3 opens the fuze box and places it in a convenient position. The projectile being held by No. 4, No. 3 inserts the designated fuze, being careful to note that it is fitted with its felt or rubber washer, and screws it home by hand. The fuze is given its final seating by the use of the fuze wrench. No great force should be used. If there is any difficulty in screwing the fuze home, the fuze should be removed and another inserted. If the same trouble is encountered with the second fuze, the shell should be rejected.

(4) *To remove fuzes from shell.*—If for any reason a projectile which has been fuzed is not to be fired, the fuze will be removed. The operation of inserting a fuze is reversed. If the adapter starts to unscrew with the fuze, the unscrewing must be stopped at once and the shell disposed of as directed by the executive.

■ 27. No. 4.—*a. Enumeration of duties.*—(1) To set the fuze when the bracket fuze setter is used.

(2) To hold the round while No. 3 sets the fuze, when the hand fuze setter is used.

(3) To hold the round while No. 3 screws the fuze into the shell.

(4) To pass the round to No. 2.

b. Detailed description of certain duties.—(1) *To set the fuze when the bracket fuze setter is used.*—When the command CORRECTOR (SO MUCH) is given, No. 4 receives a round of shrapnel from No. 5, removes the waterproof cap of the fuze, and inserts the point of the projectile in the bracket fuze setter, taking care that the lug nearest the point of the fuze engages in the groove in the fuze setter. When No. 3 has called "Cut," No. 4 turns the projectile with a steady and uniform motion in a clockwise direction until further movement is stopped. In turning the projectile, No. 4 stands to the rear of the fuze setter, facing to the right front. His left hand, back down, grasps the round at or near the forward end of the cartridge case. The palm of the right hand is placed on the base of the cartridge case, the fingers grasping the edge of the base. While turning the projectile, No. 4 takes care to hold it firmly against the guide and to keep the fuze well engaged by a steady pressure on the base of the cartridge case with his right hand. No. 4 then removes the round by lifting it directly out of the fuze setter, taking care not to strike the lugs of the fuze against any part of the fuze setter. The time of burning may be read from the graduated ring on the fuze. When directed by the chief of section, No. 4 will read and announce the time of burning after setting the fuze. A time fuze which has been set to any desired time of burning can be reset to S (Safe) by setting the fuze-setter range ring to S, the cor-

rector to normal (30), and resetting the fuze. The fuze should be inspected to see that the *S* on the graduated time ring of the fuze is in line with the marks on the upper time-train ring and on the body of the fuze. Fuzes set but not fired will be reset to *S* (Safe), inspected, and returned to the chest or other container by No. 4. If the command PERCUSSION is given, No. 4, after removing the waterproof cap, passes the round directly to No. 2 for loading.

(2) *To hold the round while No. 3 sets the fuze, when the hand fuze setter is used.*—No. 4 holds the round while No. 3 sets the fuze. No. 4 receives the round from No. 5, removes the waterproof cap, faces to the right, and partially kneels on the right knee. He places the base of the cartridge case on the right thigh just above the knee. He grasps the round with both hands, the right arm resting on his right thigh, the left arm braced against his left thigh. The round is held firmly, pointing upward in the general direction of No. 3's head, while No. 3 sets the fuze.

(3) *To hold the round while No. 3 screws the fuze into the shell.*—When shell is being used, No. 4 holds the round while No. 3 screws in the fuze. The round having been removed from the chest or other container, cleaned, and prepared for firing, No. 4 removes the fuze plug from the fuze socket and holds the round firmly on the footboard or other convenient support, while No. 3 screws in the fuze.

(4) *To pass the round to No. 2.*—No. 4 passes the round to No. 2 in the most expeditious manner and in such a way that No. 2 is enabled to grasp the base of the cartridge case with his right hand.

■ 28. No. 5.—*a. Enumeration of duties.*—(1) To remove ammunition from the chest or other container, to clean and prepare it for firing, and to pass it to No. 4.

(2) For direct laying on a moving target, to level the angle-of-site bubble and to set the range.

(3) When necessary, to assist No. 2 in shifting the trails.

(4) To keep empty cartridge cases out of the way.

b. Detailed description of certain duties.—(1) *To remove ammunition from the chest or other container and to clean and prepare it for firing.*—No. 5, when time permits, arranges the rounds so that they are within easy reach or

partially removes them from their compartments. To remove a round from the chest (in units equipped with caissons), No. 5, standing with his left side toward the chest, grasps the base of the cartridge case with his right hand and pulls the round to the rear, across the front of his body, grasping the projectile in rear of the ogive with his left hand at the proper time to prevent the round from falling. He inspects the projectile to see that it is free from sand and dirt and that the rotating band is not burred. Any foreign matter will be removed by wiping with a piece of waste. Projectiles having burred rotating bands should be placed aside temporarily until the burrs can be removed with a file.

(2) *For direct laying on a moving target, to level the angle-of-site bubble and to set the range.*—No. 5 takes a convenient position outside the right wheel, and levels the angle-of-site bubble and sets the range in the manner prescribed for No. 1 in paragraph 24 b (2) and (3).

(3) *When necessary, to assist No. 2 in shifting the trails.*—No. 5 goes to the drawbar on the right trail, while No. 2 handles the left trail, and gives direction to the piece by shifting the trails right or left as directed by the gunner. The command is: MUZZLE RIGHT (LEFT), and the trail is shifted in the opposite direction so that the muzzle is swung in the direction indicated. At the gunner's signal, Nos. 2 and 5 lower the trails to the ground.

(4) *To keep empty cartridge cases out of the way.*—No. 5 throws the cases well to the rear of the left trail of the piece.

SECTION IX

ADDITIONAL INFORMATION ON THE SERVICE OF THE PIECE

■ 29. ACCURACY IN LAYING.—Sighting and laying instruments, fuze setters, and elevating and traversing mechanisms will be manipulated so as to minimize the effects of lost motion. This requires that the last motions in setting instruments and in laying be always in the directions prescribed. To insure accurate laying, the gunner and any other cannoneers who have duties in connection with laying the piece invariably will be required to verify the laying after the breech

has been closed. When the piece must be established on uneven ground, it is desirable for accurate firing that the three points of support, when firing from the jack, be leveled by pioneer work.

■ 30. FIRE AT WILL.—*a.* The piece being unlimbered or uncoupled and prepared for action, in case of sudden attack, when the target appears at a range of less than 500 yards, the executive may command: 1. TARGET (SO AND SO), 2. FIRE AT WILL. The chief of section repeats this command.

(1) No. 1 lays the gun by eye for elevation so that the gun is pointed approximately at the target; No. 3 sets corrector 30, range zero; No. 4, if shrapnel is used, sets fuzes continuously. The gunner keeps the piece laid directly on his part of the target throughout the firing. Based on his observation of his shots throughout the firing, No. 1 corrects the laying for elevation as may be necessary.

(2) Firing is commenced at the command of the chief of section NO. (SO AND SO) FIRE. The piece is loaded and fired as rapidly as possible until the command CEASE FIRING, or until the enemy disappears from view or actually reaches the piece.

b. In fire at will, refinements of laying are not attempted, rapidity of fire being of primary importance. Shrapnel, if available, will be used. If shrapnel is not available, shell, preferably with delay fuze, will be used. In general, the procedure in firing shell is the same as with shrapnel except that No. 1 lays so that the shell will strike at or just short of the base of the target.

■ 31. AIMING STAKES.—When a suitable natural aiming point is not visible, the piece, after it has been laid initially for direction, is referred to the aiming stakes as described in paragraph 23b (5). Two aiming stakes are used for each piece. Each stake is equipped with a light for use in firing at night. One stake is set up in a convenient location at least 100 yards from the piece. The other stake is set up at the midpoint between the first stake and the piece, and is lined in by the gunner so that the vertical hair of his sight and the two aiming stakes are all in the same vertical plane. Any lateral displacement of the piece during firing

can then be detected easily and corrected for as indicated in paragraph 32. For night use, the lights should be adjusted so that the far one will appear several feet higher than the near one. The two lights thus will clearly establish a vertical line on which the vertical hair of the sight can be laid.

■ 32. CORRECTION FOR LATERAL DISPLACEMENT.—When the gunner notes that the piece is out of line with reference to the aiming stakes, he reports that fact to the chief of section. The gunner continues to lay the piece, using the far stake, until correction is authorized by the executive. The piece is then moved back into its original position, or a correction is made as follows: The gunner lays the piece by using the far stake, then refers to the near stake, and finally lays on the far stake with the new reading. The stakes are then realined by moving the near stake. This correction is effective only when the stakes have been equally spaced as indicated in paragraph 31.

■ 33. REPORTING ERRORS.—Each member of the gun squad should be constantly impressed with the importance of reporting promptly to the chief of section any errors made by members of the gun squad. The chief of section will report errors immediately to the executive as prescribed in paragraph 22b (8).

■ 34. CEASE FIRING.—The command CEASE FIRING normally is given to the gun squad by the chief of section, but in emergencies anyone present may give the command. At this command, regardless of its source, firing will cease immediately. If the piece is loaded, the chief of section will report that fact to the executive. Firing is resumed at the announcement of the range or elevation.

■ 35. SUSPEND FIRING.—The command SUSPEND FIRING is given only when the battery is firing on a prearranged schedule and a temporary halt in the firing is desired. At this command, firing is stopped, but settings continue to be altered in conformity with the schedule. If the piece is loaded, the chief of section will report that fact to the executive. Firing will be resumed at the command RESUME FIRING.

■ 36. CHANGES IN DATA DURING FIRING.—The announcement to the gun squad of any new element of firing data serves as a signal to stop all firing *previously ordered but not yet executed*. If the piece is not loaded at the announcement of a new element of firing data, the new data will be set off and firing resumed at the announcement of the range or elevation. If the piece is loaded with shrapnel and the new data require a change in the fuze setting, the piece will be unloaded (par. 37). If no change in the fuze setting is required or if the piece is loaded with shell, the new data are set off, and the firing is resumed.

■ 37. TO UNLOAD THE PIECE.—*a.* When the command UNLOAD is given, No. 1 opens the breech, and No. 2, standing at the breech, receives the ejected round with both hands. In case the extractor fails to eject the round, the rammer must be used.

b. No. 1 takes the sponge-and-rammer staff and inspects the rammer head to see that it is thoroughly clean and the recess for the fuze is free from any foreign matter. Under the direct supervision of an officer, he inserts the rammer head in the bore and pushes it carefully in until it encloses the fuze and comes in contact with the projectile. He pushes the rammer head gently against the projectile and, if necessary, taps the rammer staff lightly to dislodge the projectile. He then pushes the projectile out of the breech while No. 2, standing at the breech, receives the round in both hands.

c. To unload a shell fitted with the M-46 or M-47 type fuze, the special rammer head for handling such fuzes must be used. When practicable the procedure prescribed in TR 1370-A should be followed.

■ 38. MISFIRES.—In the event of a misfire, at least three attempts to fire the primer will be made. The breechblock will not be opened until at least 2 minutes have elapsed after the last attempt to fire (AR 750-10). Rounds which have misfired will be removed from the battery position and disposed of as prescribed in TR 1370-A.

■ 39. AMMUNITION.—*a.* Ammunition must be protected from damage, especially to rotating bands and cartridge cases.

When it is received, it should be sorted into lots and placed in the best available storage. Ammunition data cards should be retained until after all ammunition pertaining thereto is expended. Fuzes must not be stored with other components, and all components should be kept in their waterproof containers until their early use is anticipated. Protection should be provided against moisture, dirt, the direct rays of the sun, and, so far as practicable, against hostile artillery fire and airplane bombs. Protection against weather, dirt, and sun may be obtained by the use of paulins below and above the ammunition, and suitable dunnage below and between the layers. Protection against hostile fire may be obtained by the use of small dispersed stacks, trenches, or dugouts.

b. Care must be exercised to keep sand and dirt out of the adapter threads of unfuzed ammunition. The fuze wrench must be used to seat fuzes.

c. With HE shell, Mk. I or Mk. IV, or chemical shell, Mk. II, the M-46, M-47, Mk. IV, or Mk. V fuzes may be used. The M-35 fuze may be used with the normal charge.

■ 40. THE SECTION DATA BOARD.—When positions are occupied for more than a few hours, a data board may be used by each section for recording such items as base deflection, calibration corrections when appropriate, minimum range or elevation, data for primary defensive fire missions, and other data the need for which may be urgent.

■ 41. FIRING-JACK FLOATS.—Wooden floats may be prepared for the firing jack for use in soft and muddy ground, to prevent the jack from sinking so far into the ground that the weight of the gun is wholly or partially on the wheels. Such floats may be devised of timbers and should be at least 2½ feet long and 1½ feet wide.

■ 42. FIRING FROM THE WHEELS.—In an emergency, the piece may be fired from the wheels, with the trails closed or open. In this case, the chief of section must watch the degree of traverse and elevation closely to be sure that the gun in recoil will not strike the trails. As soon as practicable, the trails should be opened and the piece raised on the firing jack.

SECTION X

CARE AND MAINTENANCE OF MATÉRIEL

■ 43. GENERAL.—*a.* This section covers such operations in the care and maintenance of the matériel as may be performed by a battery in the field.

b. Complete instructions for battery maintenance, including disassemblies, are found in the Technical Regulations and Standard Nomenclature Lists referred to in paragraph 2, especially TR 1305-75A (now TR 320-95) and SNL C-12. Operations not covered therein are the function of the ordnance maintenance company.

c. In general, the battery is charged with *preventive* maintenance, that is, with routine cleaning, lubricating, and preserving. Certain classes of repairs, adjustments, and replacement of parts may also be made under the direction of an officer or the chief mechanic. Parts which may be drawn by a battery for replacement purposes are indicated in SNL C-12 by the symbol %. Unless specifically prohibited, such parts may be installed by the battery mechanic. For routine care and maintenance, specific duties are assigned to individuals, squads, or sections, and a strict accountability for the proper performance of such duties is enforced.

d. The following operations may be performed within the battery:

- (1) Draining and replenishing recoil liquid.
- (2) Removal or adjustment of respirator.
- (3) Removal of gun from carriage.
- (4) Removal, disassembly and replacement of parts of the breech, operating, and firing mechanisms.
- (5) Removal or adjustment of equilibrators.
- (6) Dismounting recoil mechanism from the cradle.
- (7) Removal, care, and maintenance of wheels and wheel bearings, including tires.
- (8) Maintenance and adjustment of brake mechanism.
- (9) Care and maintenance of the firing jack.
- (10) Adjustment of the automatic pole support.
- (11) Replacement of minor parts or assemblies as listed in the Standard Nomenclature List, such as the flexible joint on the traversing handwheel shaft, traversing and elevating

stops, drawbar assembly, shoulder guard assembly, screws, nuts, cotter pins, gear case covers for semiannual cleaning, etc.

■ 44. CLEANING.—*a.* Dirt and grit accumulated in traveling or from the blast of the piece in firing settle on the bearing surfaces, and in combination with the lubricant form a cutting compound. Powder fouling attracts moisture and hastens the formation of rust. At lulls during firing and immediately after firing, the piece must be thoroughly cleaned. At other times it should be cleaned at intervals not exceeding 2 weeks, depending upon the use and condition. Dirt on nonbearing surfaces can usually be removed by water; lubricated or other greasy parts must be cleaned with dry-cleaning solvent applied with a rag. The procedure in cleaning the bore and breech mechanism is described in paragraph 48 *b.* The following cleaning materials are issued by the Ordnance Department for use in the field:

(1) *Soda ash* (dehydrated sal soda).—Used for cleaning the bore, breech mechanism, and firing mechanism after firing.

(2) *Dry-cleaning solvent*.—For removing grease. It is preferred to kerosene because it does not leave a corrosive film, and to gasoline because it is less inflammable.

(3) *Crocus cloth*.—This is the coarsest abrasive permitted for cleaning rust and stains from bearing surfaces.

(4) *Emery cloth*.—Used for cleaning unfinished or *non-bearing* steel surfaces only. Issued in five degrees of coarseness, of which 00 is the finest.

(5) *Burlap, jute*.—Issued for cleaning the bore.

(6) *Cotton waste, clean rags, and sponges*.—For general cleaning purposes.

b. A division of duties for members of the gun squad in routine cleaning and maintenance is as follows:

(1) The gunner—the telescope mount and gunner's quadrant.

(2) Nos. 1 and 2—the breechblock, firing mechanism, and the bore. No. 1 will clean and, if necessary, oil the range quadrant.

(3) No. 3—the fuze setter.

(4) Nos. 4 and 5—the elevating and traversing mechanisms and the recoil slides.

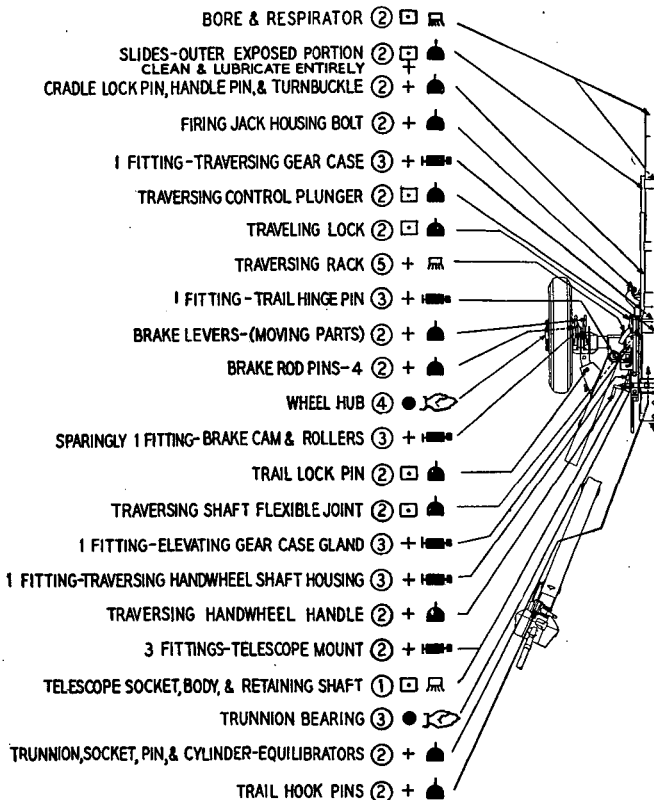
LUBRICANTS

- (1) NEUTRAL OIL
- (2) LUBRICATING OIL-USE LIGHT (SAE-20)
WHEN TEMPERATURE IS BELOW 50°F. OR
(SAE-50) FOR TEMPERATURE ABOVE 50°F.
- (3) MINERAL LUBRICATING GREASE
- (4) FIBER WHEEL BEARING GREASE
- (5) GRAPHITE LUBRICATING GREASE

HOW APPLIED

- [oiler] OILER
- [gun] PRESSURE LUBRICATING GUN
- [brush] BRUSH OR CLOTH
- [hand] BY HAND APPLICATION

NOTE.—With obvious modifications
FIGURE 6.—Lubrication chart,

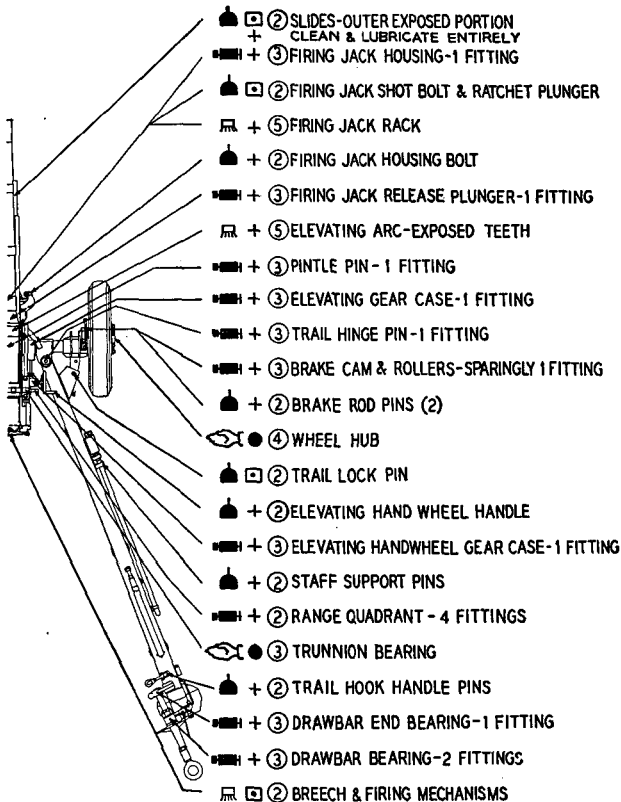

WHEN APPLIED

☐ DAILY DURING CONSTANT USE, OTHERWISE EVERY TWO WEEKS.

+ EVERY TWO WEEKS

● EVERY SIX MONTHS

NOTE - Before firing and during lulls, clean and oil bearing surfaces of breech and firing mechanisms, and slides. After firing, clean and lubricate bore, breech and firing mechanisms, slides, and all other exposed and unpainted surfaces. Wheel bearings should be repacked after immersion in water.

this chart applies also to the M2A2 gun.

75-mm gun, M2.

(5) Higher-numbered cannoneers assist in the operations as directed by the chief of section.

■ 45. LUBRICATION.—*a.* Caisson and limber wheel bearings require $\frac{1}{8}$ pint of lubricating oil daily, or every 25 miles. The oil is applied by means of the oiler at the valve in the center of the hub cap without removing the wheel. The automatic pole support on the limber should be packed with mineral lubricating grease at each disassembly. All other parts on these vehicles should be oiled with lubricating oil weekly.

b. To facilitate identification, all oil holes and grease fittings should be made conspicuous by circling with bright red enamel.

c. Lubrication instructions for the gun and carriage are covered in figure 6.

■ 46. PROTECTION AGAINST CHEMICALS.—Whenever chemical attacks are anticipated, all bright parts should be covered with oil. After a gas attack, the oil is wiped off and fresh oil applied. If mustard or other persistent gas is used, absorbent objects may be deeply contaminated, and even hard surfaces may be dangerous for 6 to 8 days if the chemical is not neutralized. Surfaces should be sprinkled with calcium hypochlorite or chloride of lime or painted with a whitewash made from either. After 2 to 6 hours the lime is washed off and the matériel rinsed thoroughly with water. When large quantities of water are available, warm (but not boiling) water should be used instead of whitewash. In all cleaning operations, the gas mask and special gasproof gloves must be worn. All cleaning rags, sticks, etc. are disposed by *burying*. They must not be burned as the heat will disseminate dangerous vapor.

■ 47. RECOIL MECHANISM.—*a. General.*—Battery maintenance of the recoil mechanism is limited to exterior cleaning and lubricating, draining and filling with recoil oil, adjustment of the respirator, and disconnection of the piston rod from the coupler. Only the heavy low-pour-point recoil oil as issued by the Ordnance Department may be used in the recoil mechanism. A full reserve of oil for the recoil

system amounts to approximately one half the contents of the screw filler. In using the screw filler, care must be exercised to prevent crossing the threads. The screw handle must be turned with both hands. The amount of oil reserve in the system is shown by the position of the oil index with reference to the rear face of the counterrecoil-cylinder rear sealing plate at the rear of the cradle, as follows:

(1) *No reserve.*—The indicator is at the bottom of the recess. The piece must not be fired in this condition.

(2) *Full reserve.*—The end of the indicator is even with the rear face of the sealing plate.

(3) *Excess reserve.*—The indicator projects beyond the rear face of the sealing plate. The piece must not be fired in this condition.

b. Operation prior to traveling.—In order to hold the gun firmly in battery during travel, excess reserve oil should be added to the recoil system until the index shows excess oil reserve and stops moving to the rear. This requires about one screw filler of oil for filling from a no-reserve status.

c. Operations prior to firing.—(1) Before firing, the reserve oil should be extracted until an insufficient reserve is indicated, then a full reserve should be established by inserting oil until the index is flush with the rear face of the rear sealing plate.

(2) The respirator should be removed in order to clean the front interior of the recoil cylinder and to inspect for excess oil leakage.

(3) The front end of the recoil cylinder, the filling-and-drain-plug hole, and the oil-index recess should be examined for oil leakage. The presence of a few drops of oil at any of these places is not important, but if there is an undue leakage the piece must not be fired, and the condition should be reported to the Ordnance Department.

d. Operations during firing.—(1) During firing, the recoil mechanism should be maintained at full reserve, the respirator kept properly adjusted, and the slides kept clean and properly lubricated.

(2) The chief of section constantly verifies the complete return of the piece to battery. Firing may be continued as long as the cradle index (at right rear of breech hoop and

cradle) remains between the two reference marks on the breech hoop.

(3) The chief of section constantly observes the behavior of the recoil mechanism in firing, and takes such action in the case of malfunctioning as is indicated below:

Malfunction	Cause	Correction
Oil index not functioning.	Index stuck or sluggish because of paint, dirt, or overtight packing.	Withdraw all reserve oil, then insert approximately one-half the capacity of the oil screw filler. Tap the oil index lightly as oil is being added. If it still fails to function notify the ordnance maintenance company. (In an emergency, after bleeding and refilling, the piece may be fired until the gun returns into battery with a shock, when reserve oil should be extracted, or the gun falls to return to battery, when additional oil should be inserted.)
Failure of gun to return to battery.	(1) Insufficient oil reserve. (2) Dirt or obstruction on the slides, damaged slides, damaged piston rod or piston, excessive internal friction or low nitrogen pressure.	(1) Insert sufficient fresh oil to bring the index even with the rear face of the rear sealing plate. (2) Clean and lubricate the slides. If this fails to correct the trouble, send recoil mechanism to the ordnance maintenance company for repair.
Return of gun to battery with a shock.	(1) Air from recoil cylinder escaping too fast through respirator. (2) Too much reserve oil.	(1) Adjust respirator to give smaller air-vent setting. (2) Withdraw reserve oil until the index indicates an insufficient reserve, then insert sufficient oil to bring the index even with the rear face of the rear sealing plate.

■ 48. BARREL ASSEMBLY, BREECH MECHANISM, AND FIRING MECHANISM.—*a. Operations during firing.*—(1) During firing, all exposed bearing surfaces must be kept clean and covered with a thin film of lubricating oil.

(2) Whenever the rate of firing permits, the bore should be swabbed with clean water and a sponge.

(3) The causes and corrections of malfunctioning of the breech and firing mechanism are given in the following table:

Malfunction	Cause	Correction
No momentum to swing of firing hammer.	Broken firing-rack spring.	Replace spring.
Failure to discharge when proper percussion on primer is obtained (misfire).	Defective primer.	See paragraph 38.
Failure to discharge until after several percussions on primer (primer stuck weakly).	<p>(1) Firing rack and hammer not working freely.</p> <p>(2) Weak firing-rack spring.</p> <p>(3) Deformed firing-pin point.</p> <p>(4) Friction on lanyard.</p>	<p>(1) Disassemble firing mechanism and examine all parts for burrs or roughened bearing surfaces. Remove burrs or rough spots with crocus cloth or oil-stone. Clean off dirt and gummy oil with cleaning solvent. Dry and coat with lubricating oil.</p> <p>(2) Replace spring.</p> <p>(3) Replace firing pin.</p> <p>(4) Allow less slack when firing with a long lanyard.</p>
Failure to discharge; no percussion on primer.	<p>(1) Safety piece not in firing position.</p> <p>(2) Breechblock not fully closed.</p> <p>(3) Broken firing pin.</p>	<p>(1) Set safety piece plunger in the hole marked "Fire" or "Fir."</p> <p>(2) Close breechblock.</p> <p>(3) Replace firing pin.</p>
Failure to extract cartridge case.	Broken extractor.	See paragraph 37. Examine the edge of the chamber for burrs or deformation. Replace extractor.
Pawl fails to operate.	Broken pawl spring or broken breechblock latch spring.	If latch spring is broken, replace it. If pawl spring is broken, replace breechblock latch assembly.
Breechblock does not rotate freely.	<p>(1) Lack of lubrication.</p> <p>(2) Burrs or roughening of threads of breechblock or breech recess.</p>	<p>(1) Remove block, clean recess and threads with solvent, wipe dry; coat lightly with lubricating oil; reassemble.</p> <p>(2) Remove and clean as in (1) above. If burrs or roughness are found, the correction must be made by ordnance maintenance company.</p>
Safety bolt does not remain in upper position when coupler key is withdrawn.	Weak or broken safety-bolt spring, or spring does not engage in notch.	Replace safety-bolt assembly. If notch is deformed refer to ordnance maintenance company for correction.
Safety bolt fails to rise when coupler key is withdrawn.	Safety-bolt lug is shorn off.	<p>Replace safety-bolt assembly.</p> <p>NOTE.—The safety bolt cannot rise when the breechblock is closed; forcing out the coupler key with the breech closed results in shearing off the lug.</p>

b. Operations after firing.—(1) As soon as possible after firing, the breechblock and firing mechanism should be disassembled, the gun retracted on its slides, and all parts cleaned and lightly oiled.

(2) In disassembling the breech mechanism, the breechblock must be in the *closed* position before the extractor tang is disengaged from the extractor spindle. If the tang is disengaged with the block open, it may drop into the cam groove and jam the block.

(3) In order to retract the gun for cleaning the slides, the piston rod must be disconnected from the coupler. To do this the breechblock must be *open* or previously removed, and the cradle level.

(4) The bore, breech mechanism, and firing mechanism are washed with a solution of $\frac{1}{2}$ pound of soda ash or 1 pound of sal soda in 1 gallon of water. Cleaning the bore is accomplished by means of a swab of burlap stitched around the end of the rammer staff. No attempt should be made to remove copper fouling. When all powder fouling has been removed, the bore should be swabbed with clear water and then wiped dry. Finally, it should be lightly coated with lubricating oil, either light or heavy depending on the weather. The process may have to be repeated on successive days if there is evidence of sweating. If the piece is not to be kept in constant service, the bore should be slushed with rust-preventive compound instead of oil.

■ 49. CLEANING SLIDES.—*a.* The bronze slides should be examined by retracting the gun until three fourths of the slides are exposed. Burs or rough spots are removed with a fine file. The slides should be cleaned with dry-cleaning solvent, wiped dry, and coated with a light film of lubricating oil. To retract the gun, lay the piece at zero elevation, open the breech, raise the piston coupler key latch, withdraw the key from right to left as far as it will go, and push the tube to the rear. The gun is placed in battery by reversing this procedure.

b. Periodically, or every 2 weeks when in constant service, the gun should be removed from the carriage in order to clean the entire length of the slides. The gun is removed as follows:

(1) Provide at least three heavy timbers to support the gun in a horizontal position when it is being removed.

(2) Set the brakes with the carriage in the firing position.

(3) Depress the gun and screw the equilibrator assembling nuts their full length on the equilibrator rods.

(4) Elevate the gun to zero.

(5) Open the breech, raise the piston coupler key latch, and withdraw the key from right to left as far as it will go.

(6) Push the gun to the rear, pairs of men at opposite ends of the timbers supporting the gun at either end and at the center. Place the gun on wooden blocks or a suitable rest to prevent damage to the slides.

c. To replace the gun, the procedure in *b* above is reversed.

■ 50. DISMOUNTING RECOIL MECHANISM FROM CARRIAGE AND CARE OF TRUNNION BEARINGS.—*a*. At least once every 6 months the cradle should be removed, and the trunnion bearings should be cleaned with dry-cleaning solvent, dried, and packed with medium mineral lubricating grease. The recoil mechanism holding cradle and the recoil mechanism are considered a unit and as such may not be disassembled. When an ordnance maintenance company is readily available, it is advisable that the removal of the recoil mechanism and packing of the trunnion bearings be accomplished by that unit.

b. To dismount the recoil mechanism from the carriage the procedure is as follows:

(1) Remove the telescope mount and range quadrant.

(2) Remove the gun from the carriage as described in paragraph 49 *b*.

(3) Loosen the trunnion nut screws and remove the nuts.

(4) Remove the screws in the outer trunnion ball retainers.

(5) Unscrew the trunnion cap bolts and remove the caps.

(6) Raise the recoil mechanism holding cradle and the recoil mechanism slightly, and carefully remove from each of the holding-cradle trunnions the outer trunnion ball retainer, outer bearing plate, cup, ball, inner bearing plate, and spacer.

(7) Lift the holding cradle with recoil mechanism clear of the top carriage trunnion bearings and place on wooden blocks.

c. The recoil mechanism is mounted on the carriage by reversing the procedure detailed in *b* above.

■ 51. EQUILIBRATORS.—*a.* The battery is prohibited from performing any operations other than the removal or the adjustment of the equilibrators. The adjustment and routine cleaning and lubricating of the equilibrators are accomplished without removing the assembly from the carriage.

b. The following procedure is used to adjust an equilibrator:

(1) Place the carriage in the firing position.

(2) Depress the gun until the equilibrator assembly nut can be assembled its full length on the equilibrator rod.

(3) Elevate the gun until the equilibrator trunnion pin is clear of the bearing in the top carriage.

(4) Release the equilibrator trunnion pin lock and make the desired adjustment by screwing the trunnion pin in for lesser tension or out for greater tension.

(5) After the adjustment is completed, reengage the lock, lower the cradle to seat the equilibrator trunnion pin, and remove the assembling nut.

c. An equilibrator is removed from the carriage by following the procedure outlined in *b* above except that the equilibrator trunnion pin is removed from the equilibrator assembly during operation (4).

■ 52. WHEELS AND WHEEL BEARINGS.—*a.* The care and maintenance of the wheel mechanism including tires is a function of the battery. Tire pressure should be maintained at 30 pounds. Tires are removed at least once a year and the disk and rim cleaned and painted. Every 6 months, or oftener if necessary, the wheel hubs should be removed, the old grease flushed out, new grease pressed into the space between the cleaned and dried rollers and race by hand, and the wheel bearings adjusted.

b. To disassemble the wheel hub from the spindle the procedure is as follows:

(1) Remove the hub cap.

(2) Remove the cotter pin, slotted nut, and washer from the spindle.

(3) Pull the hub from the spindle, being careful to prevent the roller bearing from falling to the ground.

c. To assemble the wheel hub on the spindle the procedure is as follows:

(1) Clean and dry the bearings and pack with fiber wheel bearing grease. See that the inner bearing is properly in place.

(2) Pack fresh grease in the cavity of the hub.

(3) Slide the wheel hub over the spindle, guiding the cup of the inner roller bearing over the cone and rollers, and the brake drum over the brake shoes.

(4) Slide the outer cone and roller on the spindle and press it firmly into its seat in the hub.

(5) Install the washer and nut, tightening the latter sufficiently to allow the wheel to revolve freely and without end play.

(6) Test the bearing adjustment by placing a short bar between the tire and the ground, at the same time holding one finger on the cage of the outer bearing. When, in working the bar up and down, a barely perceptible shake is felt, and the wheel will rotate when given a slight spin, the adjustment is correct. Insert cotter pin and attach the hub cap.

■ 53. BRAKE MECHANISM.—Brake adjustment is accomplished by rotating the adjusting wedge. Wheel bearings should be checked for proper adjustment and the brake mechanism lubricated prior to brake adjusting. The procedure for adjustment is as follows:

a. Set brake lever at full released position.

b. Jack up the wheel.

c. Adjust until a drag is felt on the wheel. Then back off just enough so the brake does not drag. Brakes must be cold.

d. The position of the hand lever is adjusted by adjusting the length of the brake rod.

■ 54. FIRING JACK.—a. To prevent the burring of the elevating gears when the gun is dropped from the jack, it should be so elevated that the gun wheels are only about 2 inches from the ground. To avoid running off the rack,

the jack should not be elevated beyond the height at which a red mark on the rack appears.

b. As soon as practicable after the first few rounds are fired in a position, No. 2 will release the firing jack, lowering the piece to its wheels, reset the jack, and again raise the jack, to ease lateral strain on the jack caused by the settling of the piece during the first few rounds.

c. The firing jack should be cleaned and lubricated at least every 2 weeks. During the cleaning, parts should be examined for undue wear and the ratchet plunger spring examined for a possible permanent set, which may result in a slippage of the jack.

■ 55. AUTOMATIC POLE SUPPORT ON THE M1918 LIMBER.—The disassembly and adjustment of the automatic pole support are described in TR 1305-A. It must be adjusted to hold the pole assembly at a height of 29 inches without support from the harness, the carriage being limbered and loaded. Malfunctioning may be caused by lack of lubrication, the pole being loose in the pole socket, the support spring not being in proper adjustment, and by a worn pintle lug or lunette. To adjust the support it must be disassembled and the spring tightened sufficiently to support a 20-pound weight suspended from the pole assembly at the neck-yoke stop. If the pintle lug and the lunette are worn, shims must be placed under the pintle adjusting bolt.

■ 56. CAISSON BAND BRAKE.—The brake mechanism is described in TR 1305-A. No dressing of any kind may be placed on the brake linings. Brake bands may slip if the linings are worn or greasy. If greasy, they should be washed with solvent and adjusted. If the lining is badly worn it must be replaced by the ordnance maintenance company. Brakes must be adjusted to give equal action on the wheels. To adjust a brake, jack up the wheel, disconnect the adjusting nut, and tighten the link. When the brake is in the "on" position, the wheel should not turn when a man stands on the outer end of a horizontal spoke. When in the "off" position the brake should not drag. In adjusting, allowance should be made for subsequent wear of the lining; initially, the lever should not come into the last notch when "on."

■ 57. SIGHTING AND FIRE-CONTROL EQUIPMENT.—*a. General.*— Especial care is required to insure the positive and accurate functioning of the sighting and fire-control mechanism. Care must be exercised to prevent denting the soft metal surfaces or scratching the glasses. Dirt should be removed from optical surfaces by brushing lightly with a camel's hair brush. Oil or grease should be removed from glass by applying alcohol or, if alcohol is not available, by breathing on the glass and then wiping lightly with lens paper or a clean, soft cloth. The steel surfaces should be kept covered with a light film of high grade lubricant to prevent corrosion. In general, the sights are correct—

(1) In *direction*, if the deflection scales read zero when the line of sighting is in a plane parallel to the vertical plane passing through the axis of the bore.

(2) In *elevation*, if the algebraic sum of the range and site settings indicates the same angle above the horizontal that is measured with an accurate gunner's quadrant on the tube.

(3) If there is no excessive lost motion between the sights and the tube.

b. Testing equipment.—Equipment used in testing sights consists of bore sights and a gunner's quadrant. The target for bore sighting may be a distant terrain object, more than 1,000 yards away, or a test target for use in close proximity. In the latter case the displacement of the axis of sighting from the axis of the bore must be correctly shown. For this gun the sight displacement is 14.5 inches to the left of and 11.375 inches higher than the axis of the bore. Aiming stakes with wooden blocks or markers attached make a suitable test target. In direction tests these may be canted as the carriage is canted, making leveling of the trunnions unnecessary. Tests can be made without the bore sights by sighting through the firing pin recess or a brass cartridge case with the primer removed, using improvised cross hairs at the muzzle.

c. Telescope mount, M15, panoramic telescope, M5, and range quadrant, M1.—Battery personnel are forbidden to disassemble any part of the telescope, telescope mount, or range quadrant, but are permitted to perform certain adjust-

ments. The following procedure may be used to insure accuracy of the sighting and laying mechanism:

(1) *Panoramic telescope and telescope mount assembly.*—

(a) Level the carriage trunnions and tube with the gunner's quadrant.

(b) Bore sight, placing the test target in alinement with the bore, or note a distant terrain object which is in alinement.

(c) Set all scales and micrometers at zero and level the bubbles.

(d) Look through the telescope. If the intersection of the cross hairs is on the appropriate part of the target the adjustment is correct. If not, make tests and adjustment of individual parts as explained in (2) to (6) below.

(2) *Longitudinal level of the telescope mount.*—(a) Center the cross-level bubble.

(b) Place a test level on the top surface of the telescope socket, parallel to the bore, and center the test bubble by means of the longitudinal-leveling knob.

(c) Note the position of the longitudinal-level bubble of the mount. If it is not centered within three divisions, correct the level vial by removing the plug from the end of the vial and adjusting by means of the four set screws.

(3) *Cross level of the telescope mount.*—(a) Center the cross-level bubble.

(b) Place the test level on top of the telescope socket, with its axis parallel to the axis of the cradle trunnions, and center the test bubble by means of the cross-leveling knob.

(c) Note the position of the cross-level bubble of the mount. If it is not centered within one division, adjust the level vial as in (2) (c) above.

(4) *Lost motion in cross-level device.*—To take up lost motion, loosen the screw which locks the nut and adjust. Reset the screw.

(5) *Panoramic telescope for direction.*—If the vertical cross hair of the telescope is not on the bore-sighted target with zero settings, put it on by loosening the two headless screws on the telescope socket, and then adjust the two headless pivot screws. Tighten the locking screws.

(6) *Panoramic telescope for elevation.*—If the horizontal cross hair of the telescope is not on the target with zero settings, put it on by turning the elevation knob of the telescope. Then loosen set screw on the knob and slip the knob around until the zero graduation registers opposite the index, being careful not to disturb the cross hair.

(7) *Range quadrant.*—(a) Lay the tube horizontal, using the gunner's quadrant.

(b) With the site bubble centered, site scales set at 300, and range and elevation scales set at zero, the movable indexes should be in coincidence. If not, adjust indexes and micrometers as indicated in (8) to (10) below, without adjusting the level vial.

(8) *Range quadrant for elevation.*—(a) Turn the elevation micrometer knob until the elevation index is opposite zero on the elevation scale, and note the position of the zero on the micrometer with respect to its index. If not in agreement, loosen the three screws in the end of the micrometer knob, hold the knob, and slip the micrometer until its zero graduation and the index are in agreement.

(b) This adjustment may also be accomplished by setting the zero on the micrometer opposite its index and then loosening the index screw and bringing the elevation scale index opposite its zero graduation.

(9) *Range quadrant for angle of site.*—Turn the angle-of-site micrometer knob until the angle-of-site index is opposite the 3 graduation and note the position of the zero on the angle-of-site micrometer with respect to its index. If not in agreement, loosen the nut in the end of the micrometer knob, hold the knob, and slip the micrometer until the zero graduation and the index are in agreement. Tighten the nut.

(10) *Indicating and designating indexes of the range quadrant.*—Turn the longitudinal leveling knob until the angle-of-site bubble is centered. Loosen the securing screws and move the gun elevation index and elevating worm wheel segment index until they coincide. Tighten securing screws.

d. *Gunner's quadrant.*—To test the gunner's quadrant, set the scales at zero, place it on the leveling plates of the piece, and level the quadrant bubble. Then reverse the quadrant

on its seat. The bubble should center itself. If it does not, it should be adjusted at the earliest opportunity by the Ordnance Department. If it must be used, apply a correction in the appropriate sense equal to one half of the measured error determined in the end-for-end test.

e. Bracket fuze setter, M1916.--(1) To eliminate looseness in either worm gear, loosen the set screw, and with a teat wrench turn the adjusting plug clockwise. Retighten the set screw. The range crank should not fall of its own weight.

(2) To eliminate end play in either worm shaft, remove the crank handle or knob by driving out the tapered pin, loosen the set screw, and tighten the bearing cap with a teat wrench. Retighten the set screw. Replace the handle or knob.

