



MK 20mm HS 820
Ammunition

Issue March 1962

Rheinmetall- G.m.b.H.-Düsseldorf

MK 20mm HS 820 Ammunition

General

Rheinmetall 20mm ammunition for automatic guns,

for AA and Infantry use,

present substantial properties which -

- give greatest safety in transport, handling and storage
- ensure reliable functioning on impact and self-destruction
- obtain maximum destructive effect on various targets
- show intense luminosity of tracer, therefore facilitate exact observation of fire
- establish similar trajectories with all types of projectiles

Types of Ammunition:

Practice Shells

H.E. Incendiary Shells

Armour-Piercing Shells with Hard Metal Core

MK 20mm HS 820, Ammunition

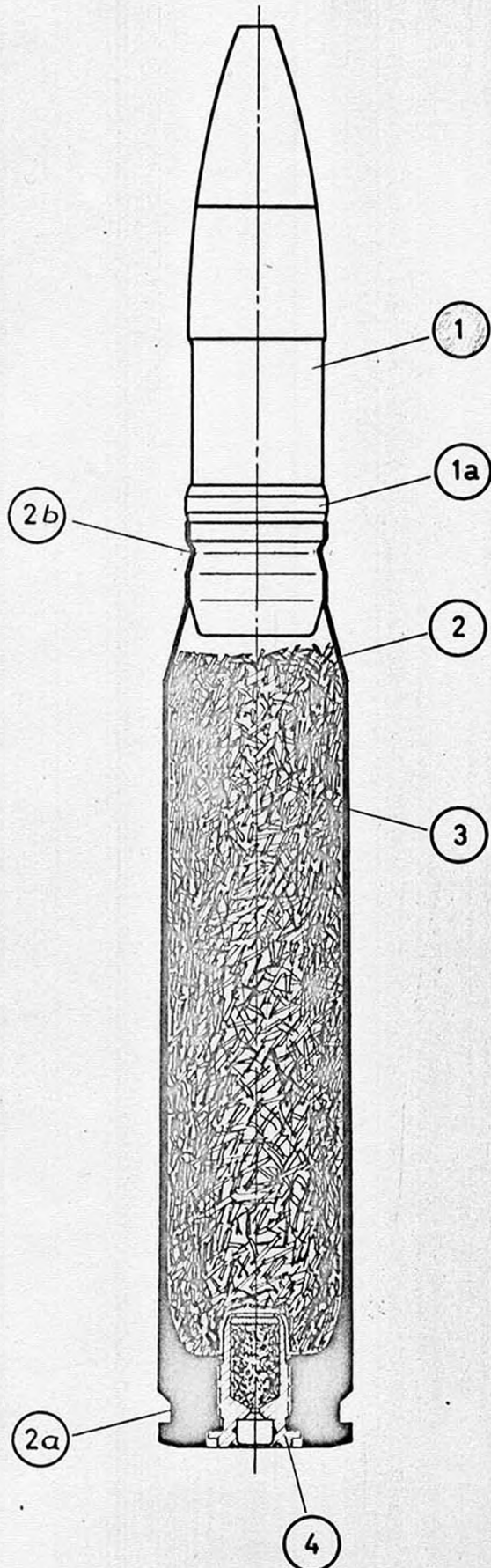

Components of Cartridge

The cartridge consists of the following parts:

Shell (1), with rotating band (1a) of sintered metal

Cartridge case (2) of steel, with extraction groove (2a) and crimping (2b)

Propellant charge (3), nitrocellulose

Propellant charge bottom primer (4)

Same type of cartridge case is used for all types of projectiles.

MK 20mm HS 820 , Ammunition

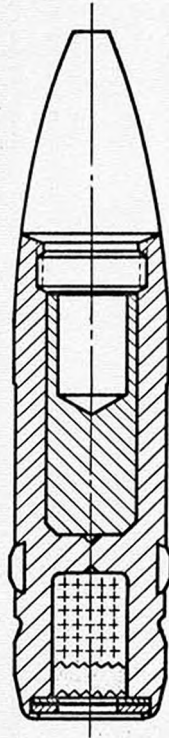

Shell 20mm, DM48A1
Practice-,Tracer

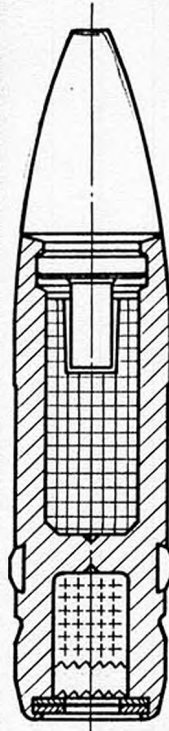

Shell 20mm, DM51A1
H.E. Incendiary, Tracer,
self-destruction-fuse

Weight of cartridge :	ca. 317 gr	
Weight of projectile :	120 gr	<i>122 ± 2 1852 grains</i>
Muzzle velocity :	1055 m/s	<i>3461</i>
Gas pressure :	3400 kg/cm ²	
Tracer, of orange colour		
Luminous track : burnout time ca. 3 sec.		
Glowing track : up to 400 m		

Shell DM51A1, H.E. Incendiary -

Fuse : Impact fuse, with muzzle safety device, self destroying
Weight of charge : 6,5 gr Hexal 60/40

MK 20mm HS 820, Ammunition

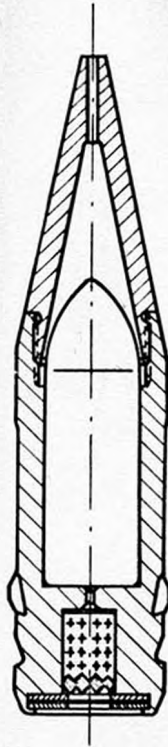

Shell 20 mm,
Armour piercing-,Tracer,
with hard metal core

Weight of cartridge :	ca. 312 gr	
Weight of projectile :	110 gr	112 gr 1697
Muzzle velocity :	1145 m/s	3756
Gas pressure :	3700 kg/cm ²	
Tracer, of orange colour		
Luminous track: burnout time ca. 3 sec.		
Glowing track: up to 200 m		

Identification of Shells

Markings can be altered to suit customer's requirements

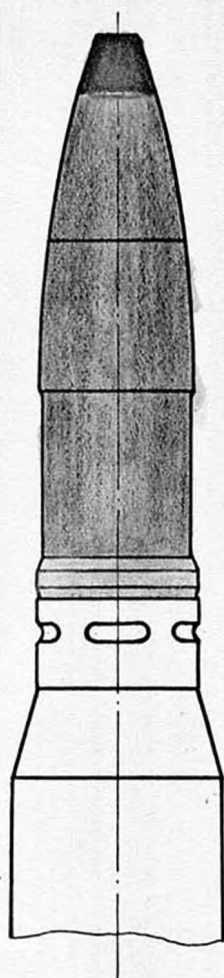

Shell, 20mm, DM 48 A1
Practice -, Tracer

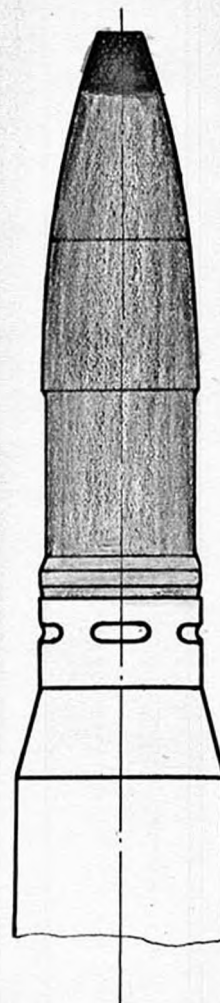

Shell, 20mm, DM 51 A1
H.E. incendiary, Tracer,
self-destruction - fuse

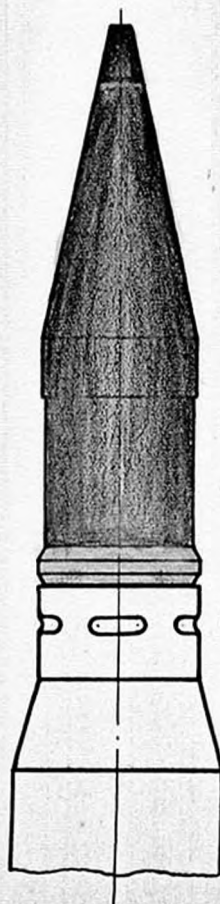

Shell 20mm,
Armour piercing -, Tracer,
with hard metal core

Shell 20mm, H.E. Incendiary, Tracer, self-destructive

Wt. of complete projectile

120 gr

Wt. of charge

6,5 gr Hexal 60/40

HEXOGEN 55±2

93.7
6.5
2.65
18.60

121.45

Fragmentation of Shell

Wt. of body, empty 93,7 gr

Body 96.5
EXPL. 6.5
FUZE 16.9
TRAC 1.5

121.4

PEC. 120±2

Fragments, groupe	Wt. of fragments gr	Number of fragments	Wt. of fragments per groupe gr	Groupe share of total in percent
1	0 - 0,5	188	35,0	37,35
2	0,5 - 1,0	23	18,0	19,21
3	1,0 - 2,0	3	4,0	4,27
4	2,0 - 3,0	3	7,0	7,47
5	3,0 - 5,0	3	12,0	12,81
6	5,0 - 10,0	3	16,0	17,08
Total of fragments		223	92,0	98,19

MK 20 mm HS 820, Ammunition

Specification		Shell 20mm DM48 A1 Practice-, Tracer	Shell 20mm DM51 A1 H.E. Incendiary, Tracer, self - destruc- tion - fuse	Shell 20mm Armour piercing-, Tracer, with hard metal core
Wt. of projectile	gr	120	120	110
Wt. of cartridge	gr	317	317	312
Wt. of propellant	gr	51	51	56,5
Wt. of charge	gr	-	6,5	-
Muzzle-velocity	m/s	1050	1050	1145
Gas pressure	kg/cm ²	3400	3400	3700
Tracer, colour		orange	orange	orange
Burnout-time	sec	ca 3	ca 3	ca 3
Glowing track	m	up to 400	up to 400	up to 200

Firing Table for Ground Targets 20mm Ammunition

Muzzle velocity 1050 m/s
 Weight of Shell 120 gr
 Spec. Weight of Air 1225 g/m³

Range m	Elevation -	Time of Flight sec	Remaining Velocity m/s
0	0	0	1050,0
100	0,5	0,097	1008,2
200	1,0	0,198	966,7
300	1,5	0,304	925,6
400	2,0	0,415	885,0
500	2,6	0,530	844,2
600	3,2	0,652	803,4
700	3,9	0,780	762,7
800	4,6	0,914	722,2
900	5,4	1,057	681,4
1000	6,2	1,208	640,1
1100	7,1	1,370	598,4
1200	8,1	1,543	557,2
1300	9,2	1,729	517,4
1400	10,4	1,930	479,8
1500	11,7	2,146	444,6
1600	13,2	2,380	412,5
1700	14,8	2,631	383,9
1800	16,7	2,901	359,2
1900	18,7	3,188	339,5
2000	21,0	3,490	323,7
2100	23,5	3,805	311,0
2200	26,3	4,133	300,4
2300	29,3	4,472	290,6
2400	32,5	4,822	281,6
2500	36,0	5,183	273,2

Comparison of Trajectories

M.K. 20mm HS 820, Ammunition

— = Shell 20mm, Armour piercing-,
with hard metal core
Wt. of projectile 110gr.
Muzzle velocity 1135 m/sec

- - - = Shell 20mm, H.E. Incendiary-, DM 51A1
Wt. of projectile 120gr
Muzzle velocity 1055 m/sec

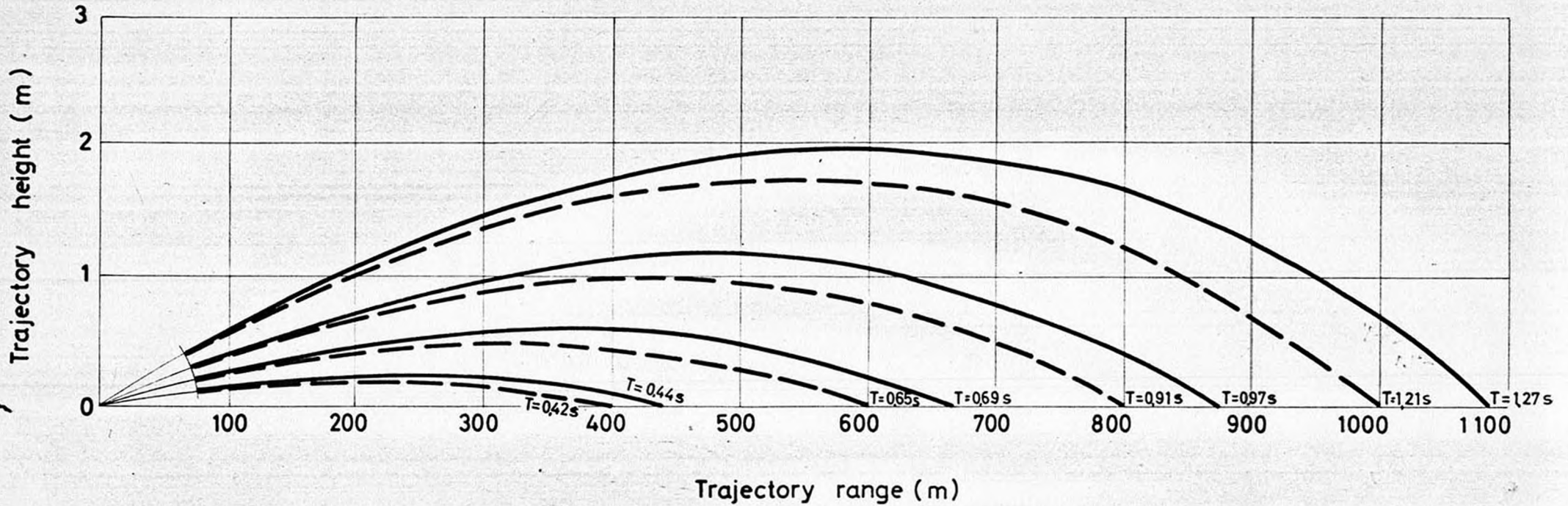

Armour-piercing, performance

Projectile: Shell 20mm, Armour-piercing,
with hard metal core

Wt. of projectile : 110 gr

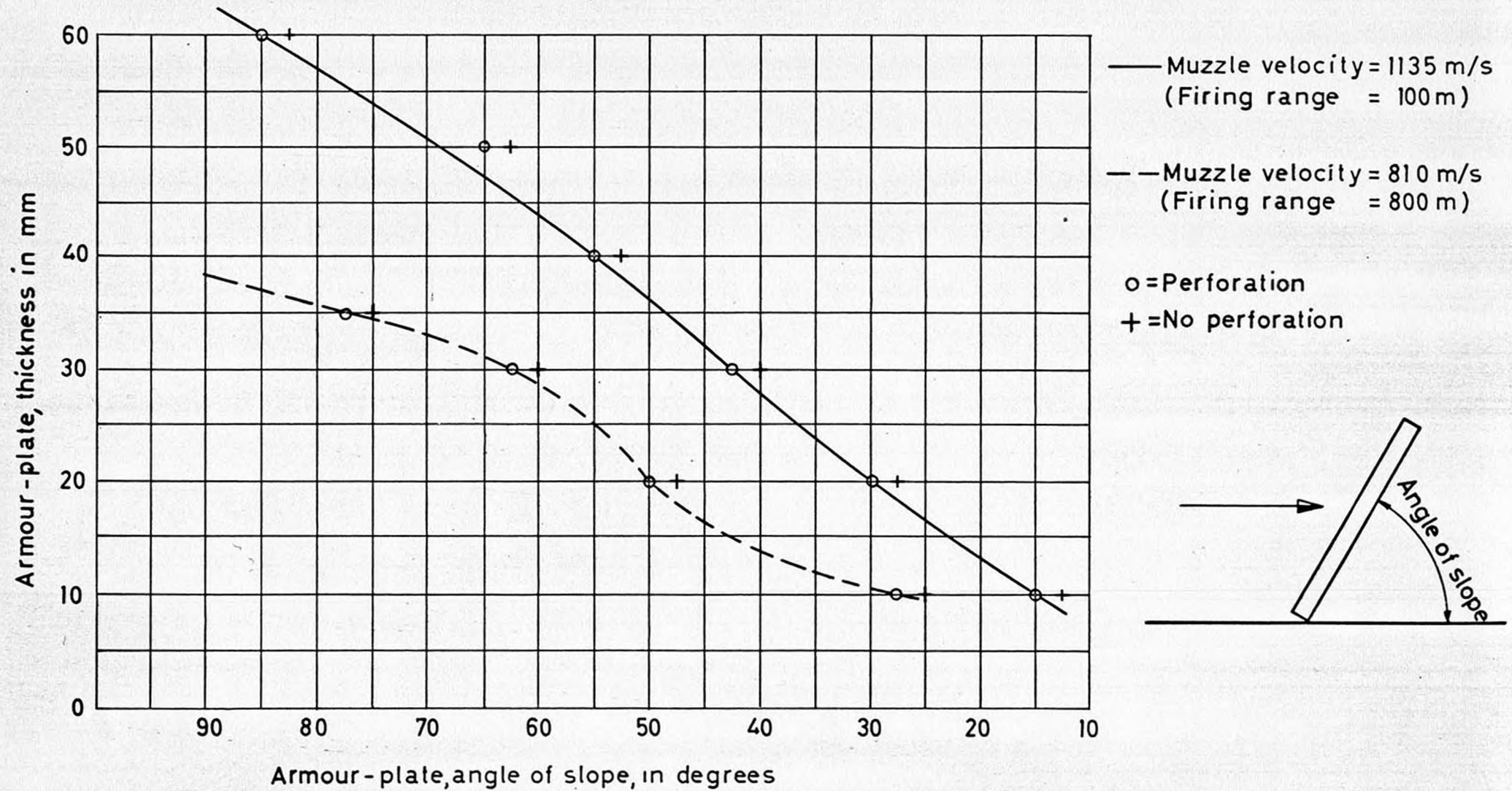

Description of Fuse "Rh"

Shell, MK 20mm HS 820

General:

The mechanism of the fuse guarantees

- 1.) Safety of storage, handling, and transport.
- 2.) Safety zone of 6m in front of the muzzle against obstacles comparable to aluminium plate of 2mm.
- 3.) High sensitive ignition effect on impact also by small angles of impact. Test range 50m, against obstacles comparable to 1mm steel plate or 1mm aluminium plate.
- 4.) Self destruction after approx. 8,5 sec. time of flight.

Operation of Fuse

1) Safety on transport

In transport the slider is kept in an absolutely locked position by arresting spring ② and safety pins.

The percussion pin ③ resting on the slider ① is thereby also kept locked.

2) Muzzle safety device

When the round is fired the pellet ⑤ due to centrifugal force runs through the bore of the holding piece ④ and is received by the hole of the slider ①.

By this the slider which rests originally in position "a" by force of gravity is now caused to slide into opposite direction to release percussion pin into striking position.

3.) Ignition on impact

When shell hits the target the diaphragm will be pressed in and the percussion pin released ③ will be forced into the detonator cap ⑧ by the ram ⑦.

The detonator cap ignites the explosive charge which disintegrates the shell.

4.) Self-destruction

Due to centrifugal force the tightened spring ⑩ is arrested by the pellet safety device ⑨ during a time of flight of approx. 85 sec.

Slackening rotating force enables spring to overcome pellet safety device and to force percussion pin ③ into the detonator cap. The self destruction is effected.

Fuse "Rh" for Shell, MK 20mm HS820

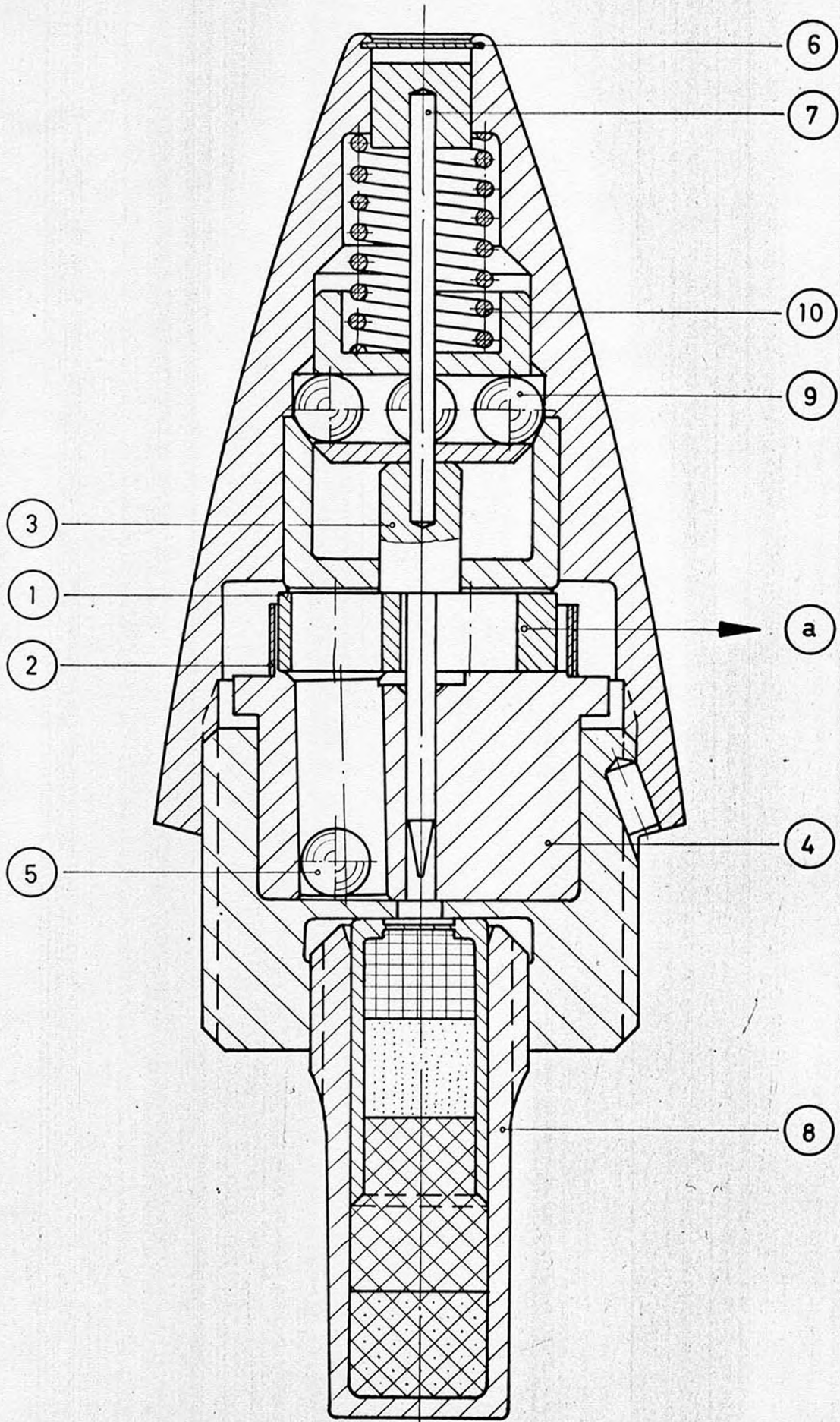

SCALE 5:1

Description of Fuse AZZDM 131 A1

Shell, MK 20mm HS 820

General:

The mechanism of the fuse guarantees

- 1) Safety of storage, handling, and transport
- 2) Safety zone of 6m in front of the muzzle against obstacles comparable to aluminium plate of 2mm
- 3) High sensitive ignition effect on impact also by small angles of impact. Test range 50m against obstacles comparable to 1mm steel plate or 1mm aluminium plate - *.0397" per mm*
- 4) Self destruction after approx. 8,5 sec. time of flight

Operation of Fuse

1) Safety on transport

Absolute safety on transport is ensured by a slider ① which is kept in a fixed position by a closely wound spiral ② of thin aluminium band. The percussion pin ③ rests on the slider and is also thereby locked.

2) Muzzle safety device

When shell is fired the centrifugal force slowly loosens the spiral ② and the slider ① is thus allowed to release the percussion pin ③ into firing position not before shell has been in free flight for min. 6 meters.

3) Ignition on impact

When target is hit by the shell the diaphragm ④ will be pressed in, and the percussion pin ③ is by a ram ⑤ forced into the detonator cap ⑥ which ignites the explosive charge and disintegrates the shell.

4) Self destruction

Mounted on a plate ⑩ is a rotation-dependent lever mechanism which after a approx. 8,5 sec. time of flight, releases a clog ⑦ and allows loosening of spring pressure ⑧ on a bush ⑨ which then lets the percussion pin ③ to be forced into the detonator cap ⑥ to effect self-destruction of the shell.

HISPANO SUIZA
Ammunition

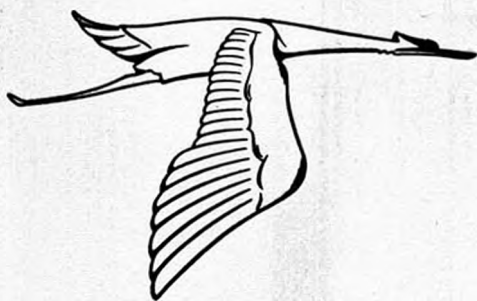

HISPANO SUIZA

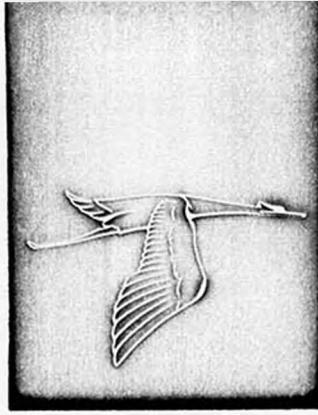

HISPANO SUIZA

Ammunition

Nº 203 VDU/AN

849 / 648 - 6201

**HISPANO
SUIZA**

HISPANO SUIZA AMMUNITION

GENERAL

HISPANO SUIZA ammunition 20 and 30 mm for automatic guns, for AA and Infantry, whose principal characteristics are :

- Complete safety in storage, in transport and handling, when firing
- Absolute reliability of functioning on impact and self-destruction
- Great explosive and destructive power
- Constant luminosity of tracer facilitating observation of fire
- Concordance with trajectories of the various types of ammunition

There are 3 groupes :

- Practice shells
- High explosive shells
- Armour-piercing shells

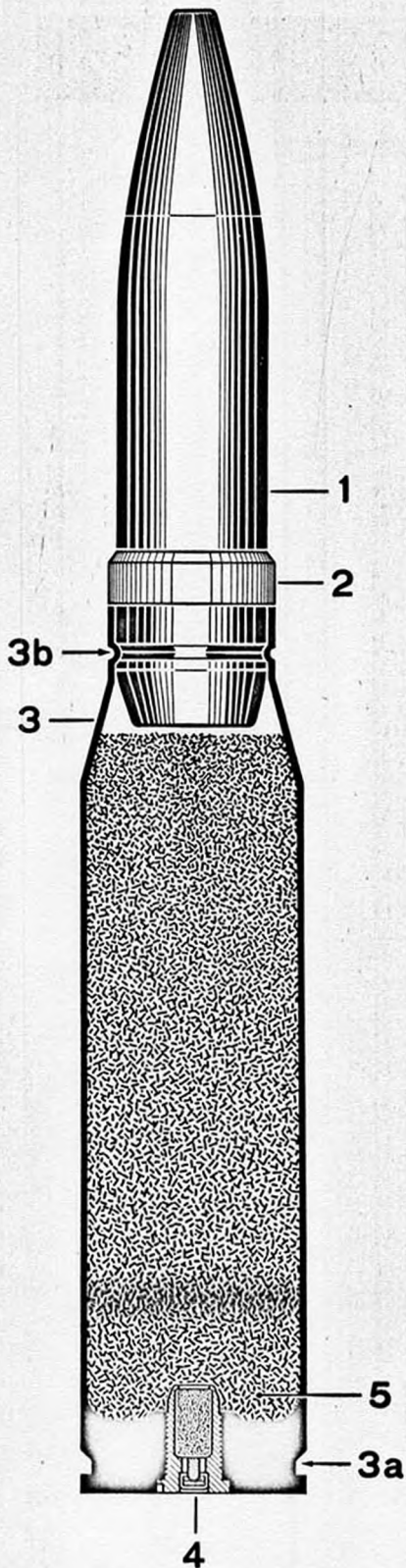

STRUCTURE OF CARTRIDGE

The cartridge consists of the projectile (1) the driving band (2) and the cartridge case (3) containing the propellant charge (5).

Shells of the same calibre and type of weapon are generally the same exterior shape, and present the same ballistic properties on the practical range.

The driving band (2) is of copper or sintered metal.

The cartridge case (3) is of copper or steel. It has at its base an extraction groove (3a) and at the head the crimping (3b) of the projectile. The bottom contains the ~~electric~~ *mechanical* primer (4).

The propellant charge (5) is nitrocellulose

HISPANO SUIZA AMMUNITION

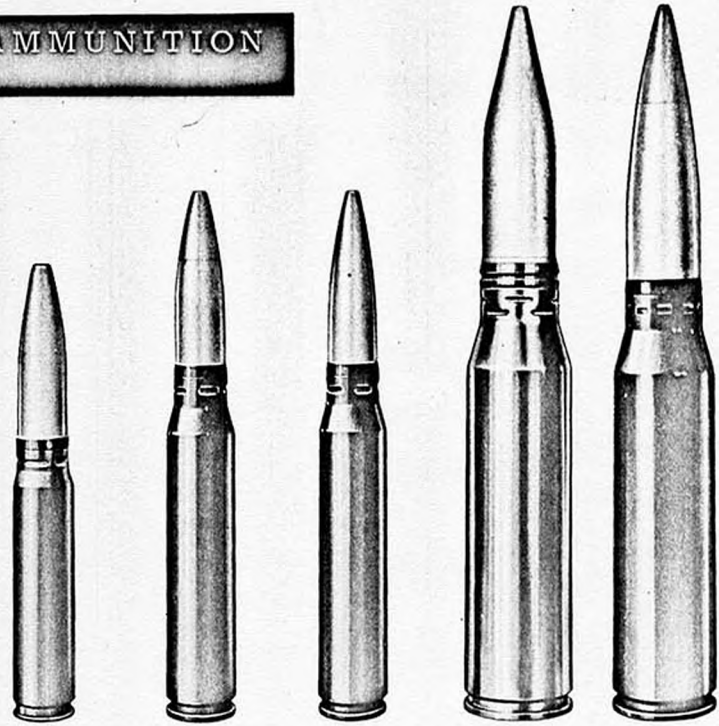

Available

	804 20mm	820 A 20mm	820 L 20mm	831A 30mm	831 L 30mm
For aircraft gun	Available	Available	Available	Available	Available
For AA/Infantry gun	Available	Available	Available	Available	Available

PRACTICE SHELLS

Type EP	Available	Available	Available	Available	Available
Type ET	Available	Available	Available	Available	Available

H.E. SHELLS

Type UIA	Available	Available	Available	Available	Available
Type UIAT	Available	Available	Available	Available	Available

ARMOUR-PIERCING SHELLS

Type RT	Available	Available	Available	Available	Available
Type RI	Available	Available	Available	Available	Available
Type RINT	Available	Available	Available	Available	Available
Type RIA	Available	Available	Available	Available	Available
Type RID	Available	Available	Available	Available	Available

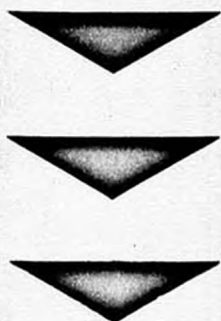

REMARKS : Shells : UIA, UIAT, RIA are filled with TRINALITE, a patented explosive made exclusively by HISPANO SUIZA.

TRINALITE has the H.E. effect of TNT, plus an incendiary and blast action due to its greater calorific power.

TRINALITE	compressed	=	1380 kcal/kg
TNT	compressed	=	950 kcal/kg

HISPANO SUIZA PRACTICE AMMUNITION
Construction

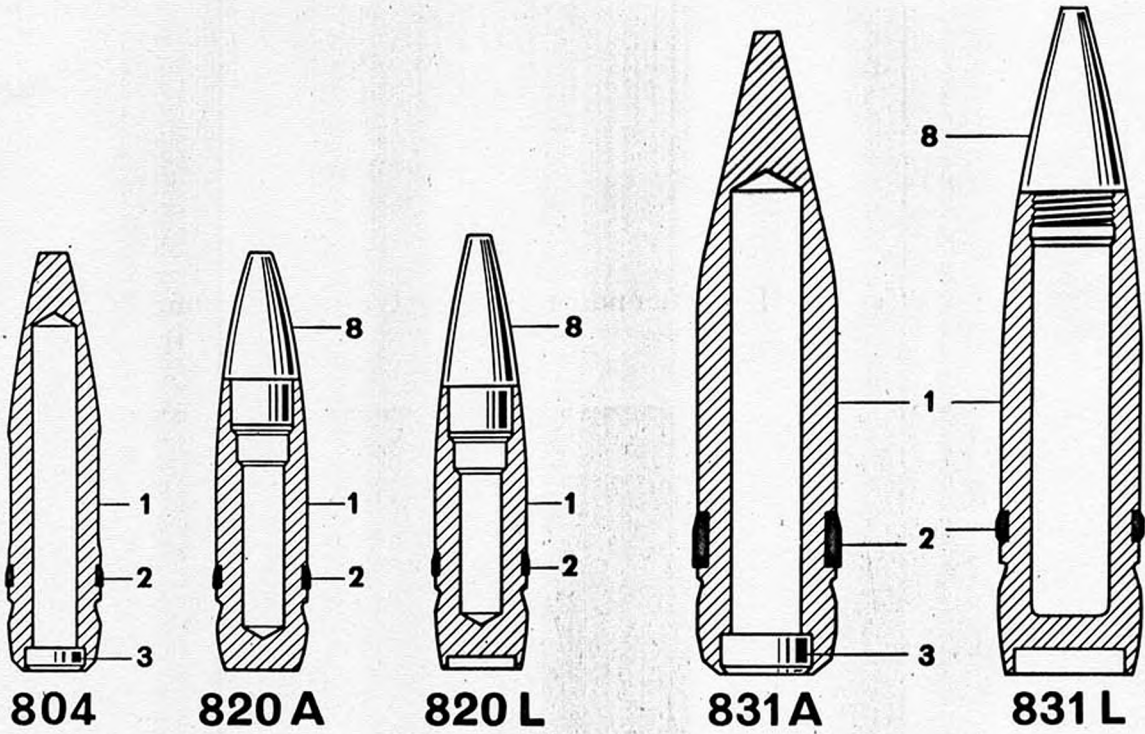

- | | |
|----------------------|-------------------|
| 1. Body | 5. Tracer |
| 2. Driving Band | 6. Ignition |
| 3. Detonator Bush | 7. Tracer stopper |
| 4. Intermediary disc | 8. Cap |

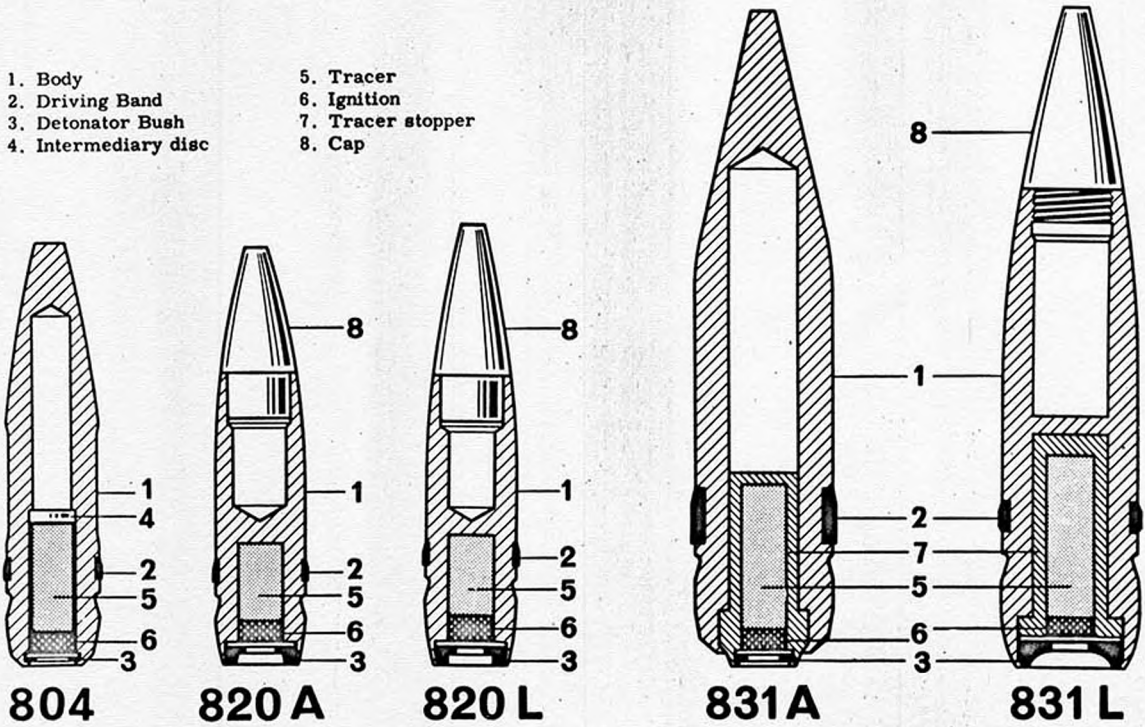

Practice shells have the same ballistic properties on a practical range as live shells.

This category comprises 2 types :

Type EP inert shell without tracer

Type ET inert shell with tracer (luminous track)

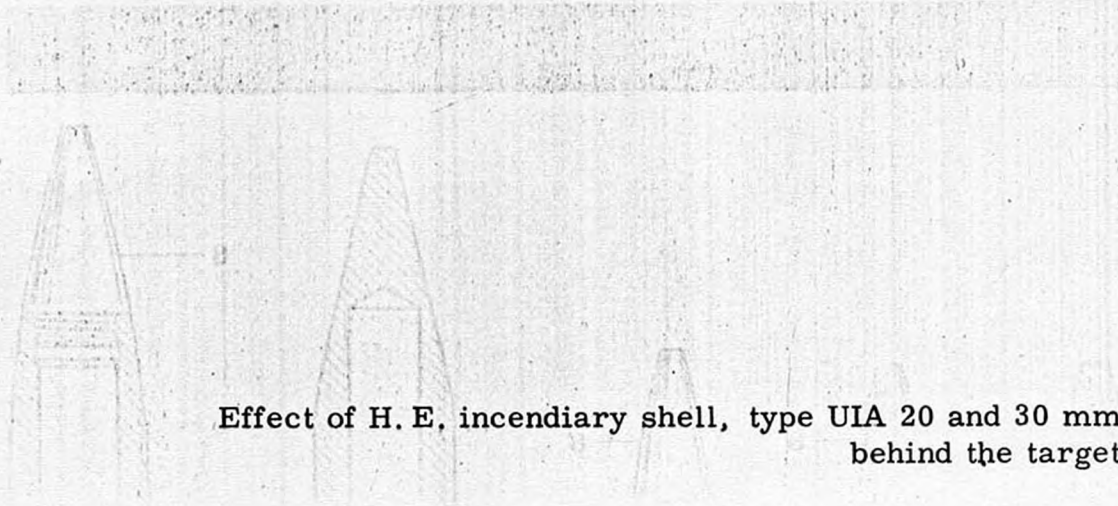

Effect of H. E. incendiary shell, type UIA 20 and 30 mm behind the target

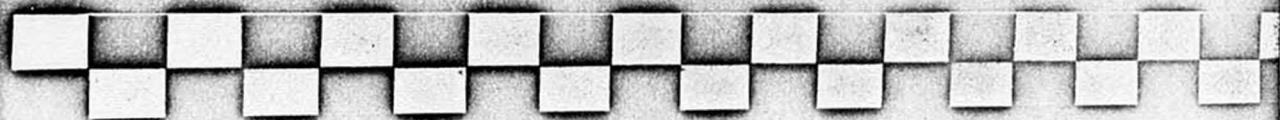
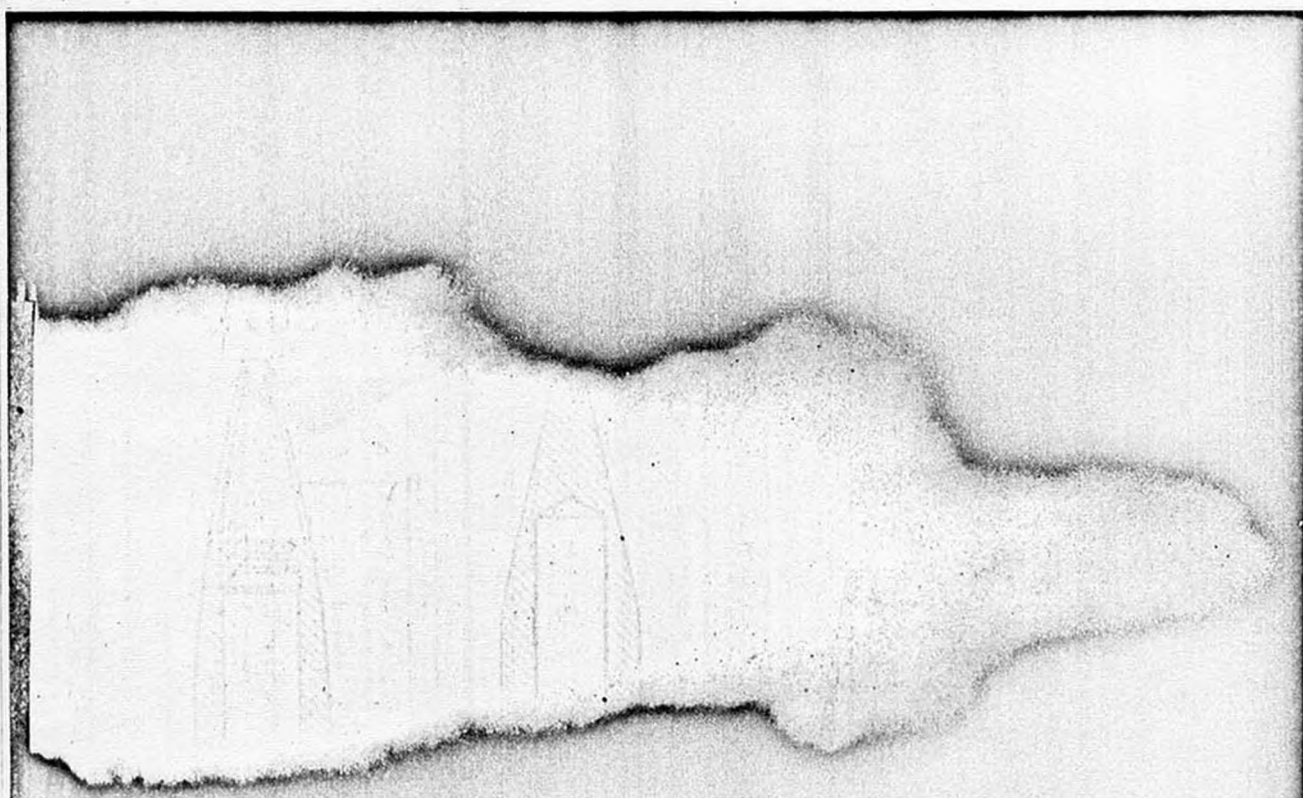

for 30 mm ammunition 10 cm
for 20 mm ammunition 7 cm

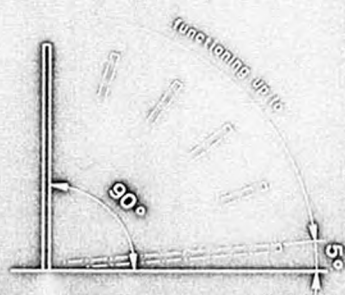

aluminium alloy target 1 mm

HISPANO SUIZA AMMUNITION
Construction

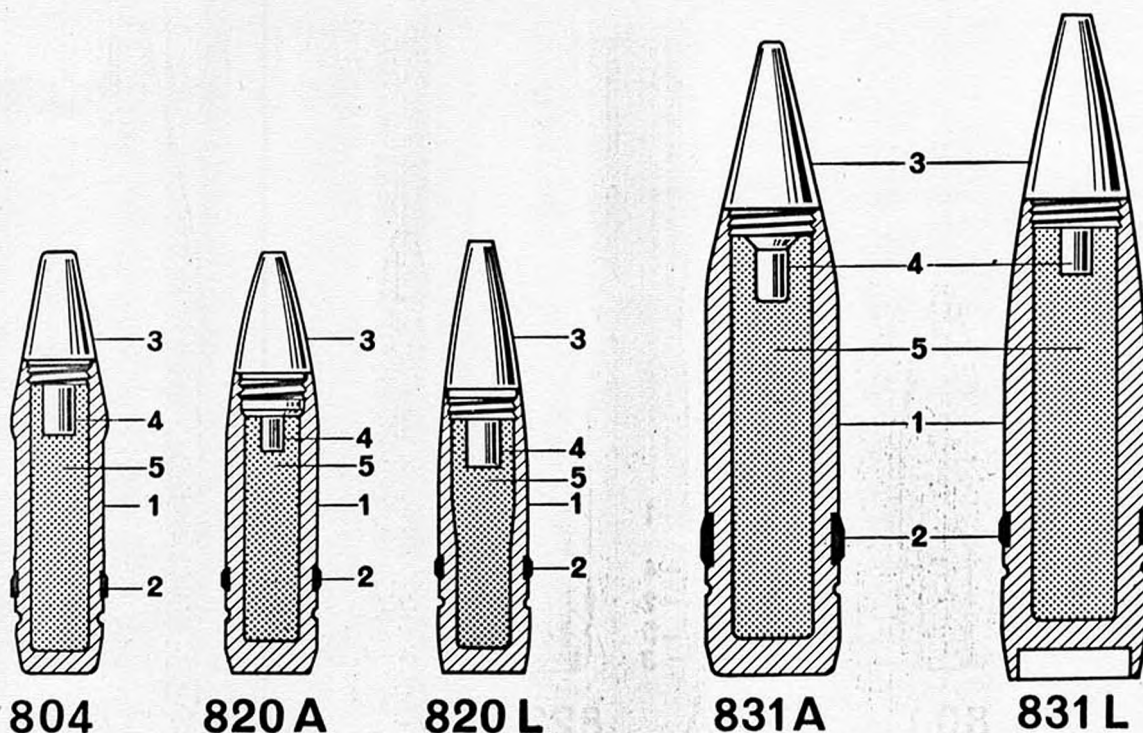

- | | |
|----------------------------|-------------------|
| 1. Body | 6. Tracer |
| 2. Driving Band | 7. Ignition |
| 3. Fuse | 8. Tracer stopper |
| 4. Detonator | 9. Plug |
| 5. H. E. Incendiary charge | |

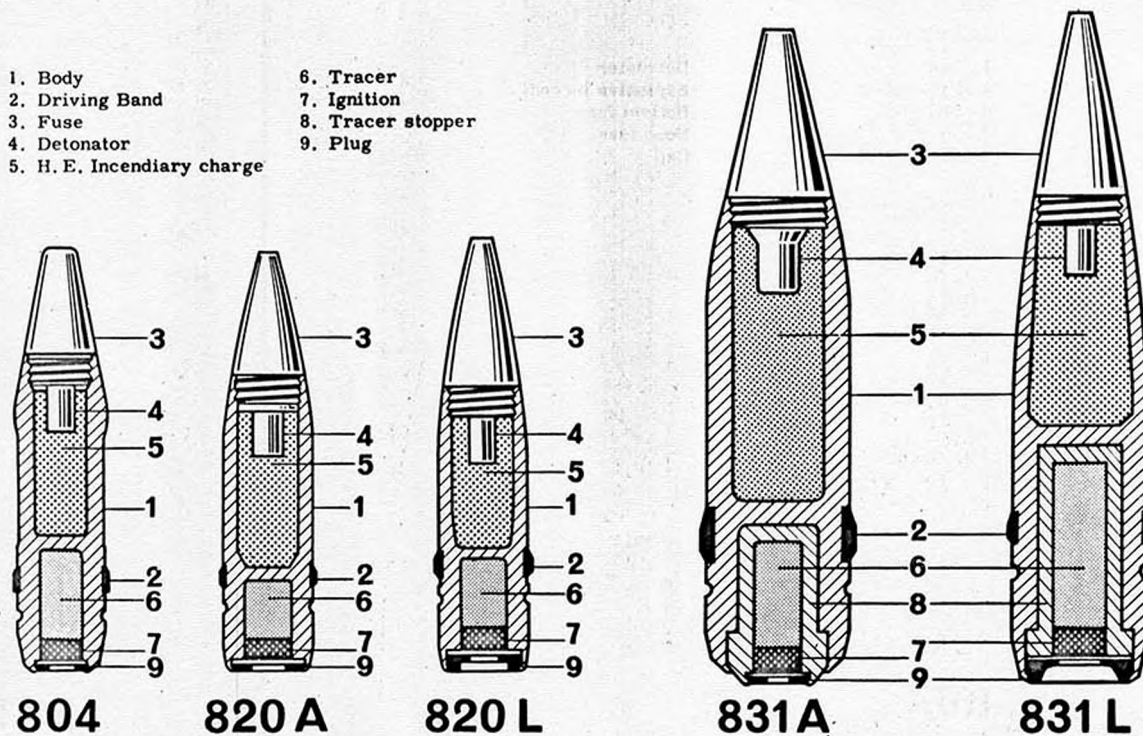

H. E. shells are provided with a mechanical fuse functioning on impact or ensuring the automatic destruction of the shell.

This category comprises 2 types :

Type UIA H. E. incendiary shell with high blast effect

Type UIAT H. E. incendiary shell with blast effect with tracer

HISPANO SUIZA ARMOUR PIERCING AMMUNITION
Construction

RT

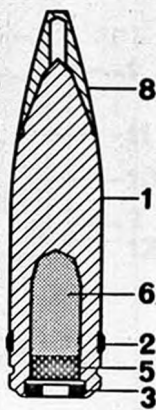

804

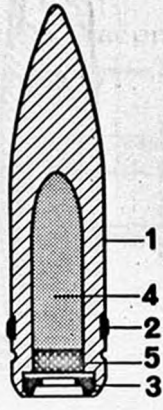

820 A

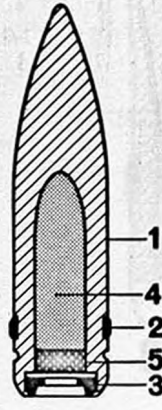

820 L

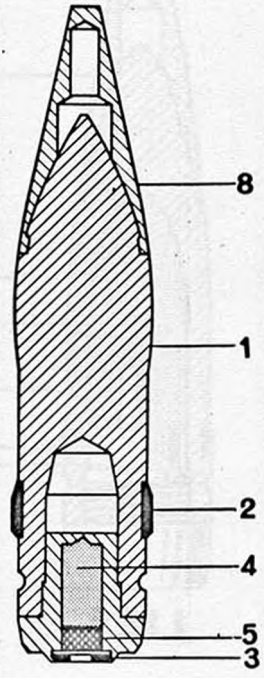

831 A

- | | |
|----------------------|---------------------------------|
| 1. Body | 10. Detonator |
| 2. Driving Band | 11. Explosive incendiary charge |
| 6. Incendiary charge | 12. Bottom fuse |
| 7. Stopper | 13. Nose fuse |
| 8. Percussion cap | 14. Cap |

RI

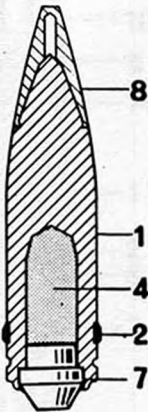

804

RINT

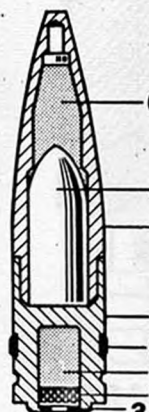

820 A

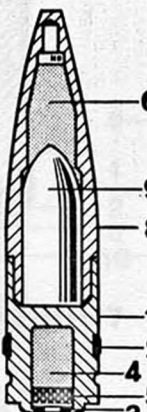

820 L

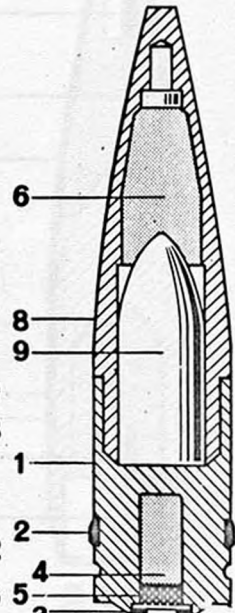

831 L

This category comprises 5 types :

- Type RT armour-piercing shell with tracer
- Type RI armour-piercing incendiary shell with ignition device
- Type RINT armour-piercing incendiary shell with hard metal core
- Type RIA armour-piercing incendiary shell with self-destruction bottom fuse

Effect behind the target and armour plating
of an armour-piercing incendiary double effect shell, type RID 20 and 30 mm

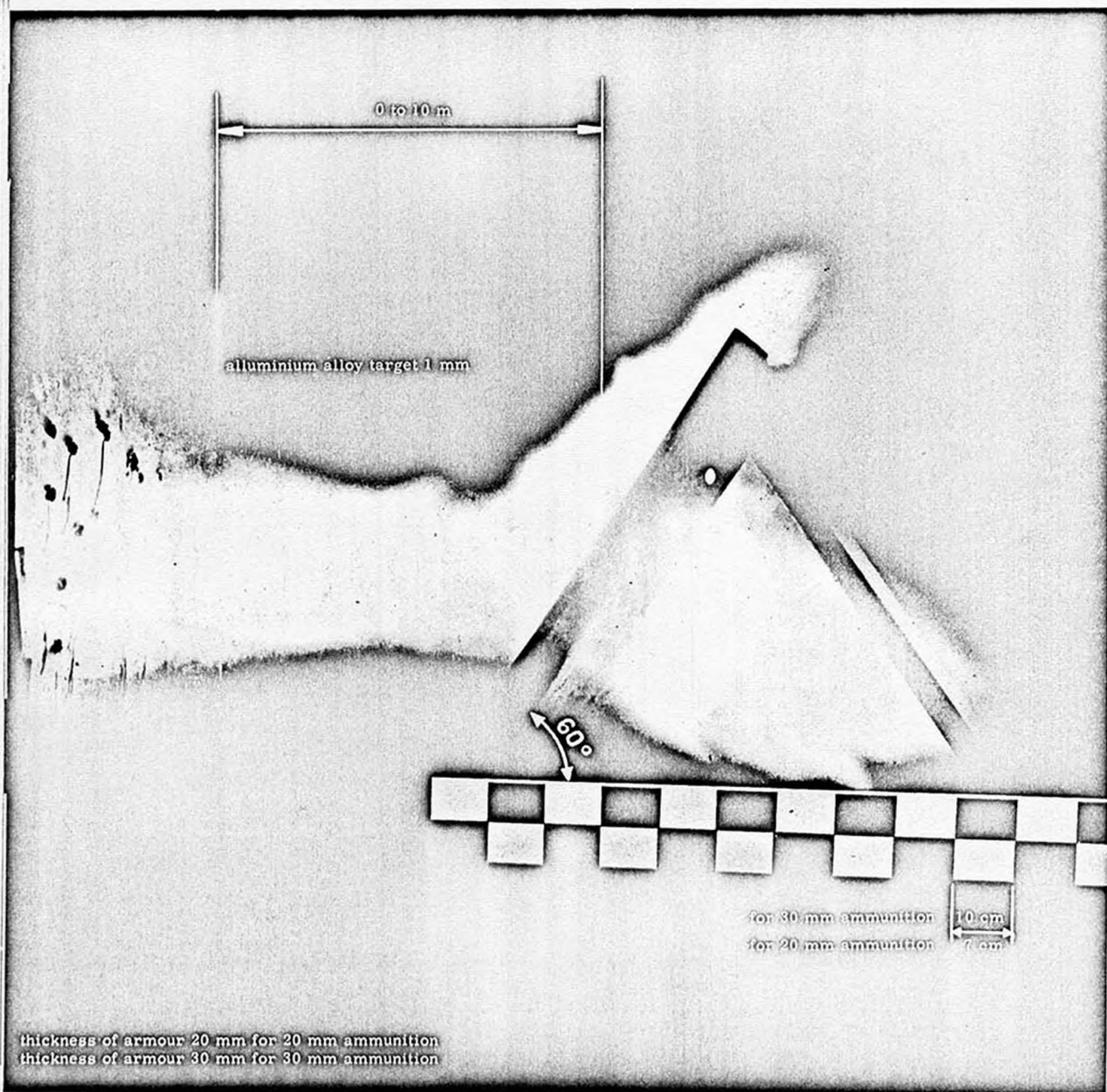

HISPANO SUIZA AMMUNITION
Standard markings can be altered to suit customer's requirements

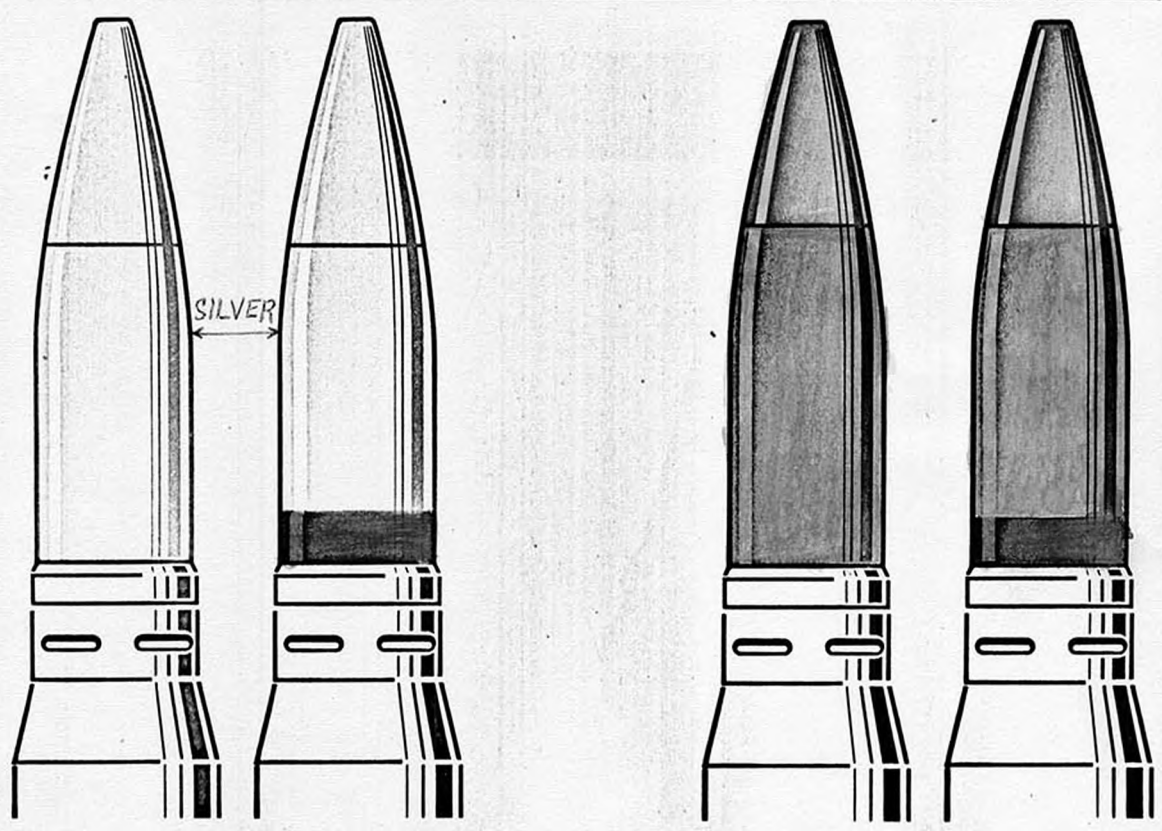

EP

ET

UIA

UIAT

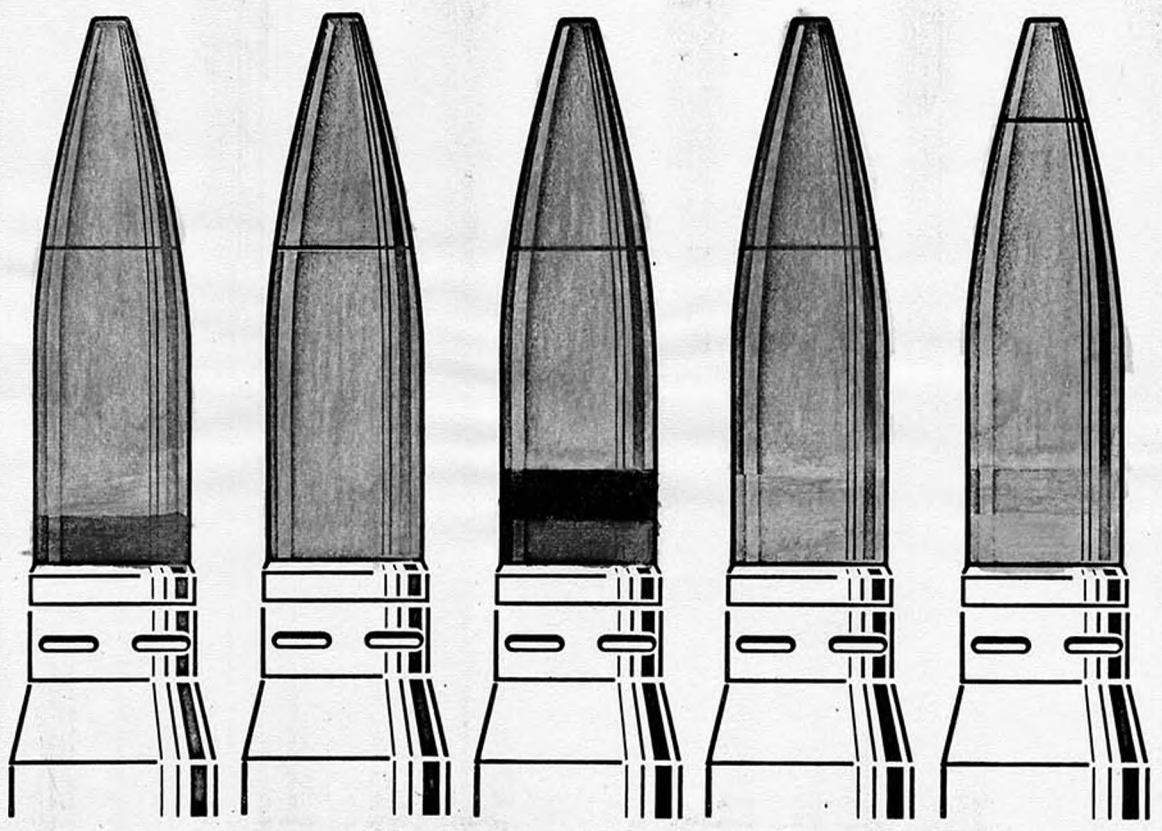

RT

RI

RINT

RIA

RID

HISPANO SUIZA AMMUNITION
Typical standard boxes

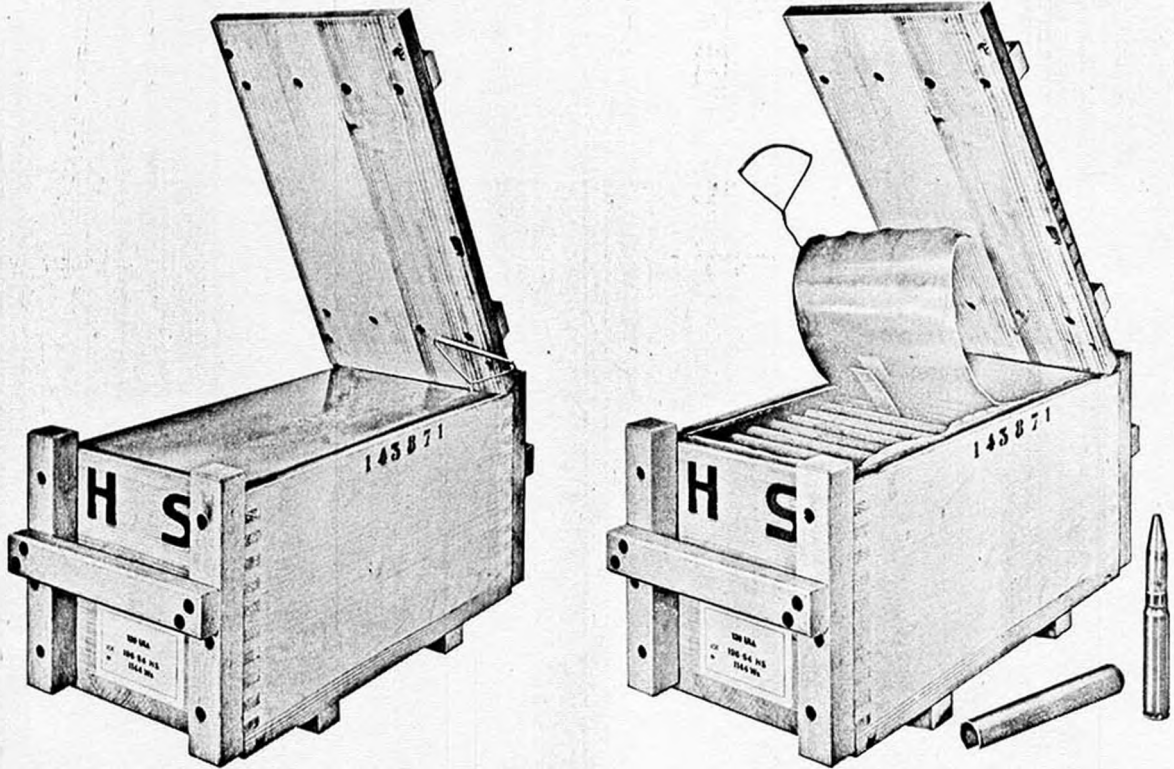

Designation	Types of ammunition				
	804	820 A	820 L	831 A	831 L
CHARACTERISTICS					
Capacity	120 cart.	100 cart.	100 cart.	20 cart.	20 cart.
<u>Weight</u> : cartridges	31 kg	32 kg	31 kg	20 kg	18 kg
packing	11 kg	14 kg	14 kg	8 kg	8 kg
total	42 kg	46 kg	45 kg	28 kg	26 kg
<u>Overall dimensions</u>					
Height of case	300 mm	230 mm	230 mm	270 mm	270 mm
Width of case	240 mm	260 mm	260 mm	240 mm	240 mm
Length of case	580 mm	780 mm	780 mm	450 mm	450 mm