

1/4 bd

U113
12
TM
1943

TM 3-375

~~U.S. Dept. of Army~~

WAR DEPARTMENT

TECHNICAL MANUAL

PORTABLE FLAME THROWERS
M1 AND M1A1

May —, 1943



Doc well
gift
non arc.

U.S. Navy Dept.

U113

TM 3-375
C 1

TM 3:375
1943

TECHNICAL MANUAL

PORTABLE FLAME THROWERS M1 AND M1A1

CHANGES }
No. 1 }

WAR DEPARTMENT,
WASHINGTON 25, D. C., 8 April 1944.

TM 3-375, — May 1943, is changed as follows:

2. GENERAL DESCRIPTION.

b. Design.

(1) Fuel unit.

(a) Two fuel tanks, joined together and holding 4 to 4.5 gallons of fuel, with a slight void above the fuel to allow for introduction of compressed air or compressed nitrogen.

g. Ratio of expended supplies (Superseded). For every 100 chargings of the M1 or M1A1 flame thrower, the following supplies may be expended:

Nitrogen contained in ten fully charged 220-cubic-foot commercial cylinders, or an equivalent amount of compressed air. 450 gallons of fuel (thickened or liquid).

Contents of two fully charged 220-cubic-foot commercial cylinders of compressed hydrogen.

(Three cylinders are required on the manifold, but only two will be completely expended in charging 100 flame thrower hydrogen cylinders).

135 pounds of gasoline thickener, if thickened gasoline is used.

3. FUEL SYSTEM.

a. Fuel tanks. Two steel fuel tanks comprise the principal parts of the fuel system. Cylindrical in shape and with rounded, closed ends, they have a combined capacity of 4½ gallons. A void of approximately ½ gallon is left in the tanks on top of the fuel to allow for expansion and to permit entry of the compressed air or compressed nitrogen. They are tested * * * of the fuel.

4. PRESSURE SYSTEM.

M574502

d. Pressure regulator assembly. This apparatus is * * * per square inch. It may be adjusted, however, to lower working pressures when desirable. The pressure regulator assembly includes:

* * * * *

12. PREPARING TO ASSAULT.

* * * * *

c. Open the hydrogen cylinder valve (Superseded). (Figure 15.) Turn the knurled handwheel until the valve is completely open. (Earlier model valves, however, should be opened only from 1/16th to 1/8th turn. Otherwise hydrogen will come out with sufficient force to extinguish the spark and prevent entry of enough air for combustion.)

13. FIRING POSITIONS.

* * * * *

d. (Added.) Fuel unit on ground. If circumstances require firing with the fuel unit on the ground, tops of the fuel tanks should be elevated at least 20° above the bottom. This elevation is similar to that shown in figure 18. If this precaution is neglected, part of the fuel will remain in the fuel tanks when the gun is fired.

16. AFTER FIRING. When the firer * * * do the following:

a. If another soldier * * * pressure cylinder valve. Close with moderate hand pressure, never with a wrench. Then point the * * * the carrier straps.

b. If the firer is alone he should first remove the fuel unit from his back, then close the pressure cylinder valve, using moderate hand pressure and not a wrench. He should then blow the fuel from the flame thrower, as in *a* above, with the fuel tanks supported in a vertical position.

* * * * *

24. EMERGENCY METHODS OF FILLING.

* * * * *

b. Filling by hand. If no other means are available for filling the flame thrower fuel tanks, they may be filled by pouring the mixture directly into the filling hole at the top of the tank, using a funnel, which may be improvised, without a screen. Stand the fuel unit on the ground or on a platform, with fuel tank plug up. Unscrew the fuel tank plug using a wrench and fill the tank to within 1 to 2 inches of the top of the plug opening. This

procedure allows sufficient void. Shake the tank unit while pouring to assure equalization of fuel in both tanks. After wiping the plug seat and threads with a clean, dry cloth, replace the plug and make it tight with the wrench.

* * * * *

28.1. (Added.) AIR COMPRESSORS. *a.* Flame thrower pressure cylinders or commercial cylinders may be charged (filled) by use of an air compressor, gasoline-engine driven, 7CFM, M1.

b. This is a skid-mounted, portable, self-contained apparatus, with a manifold capable of charging simultaneously as many as three flame thrower pressure cylinders.

c. Instructions on use of the air compressor will be found in the Technical Manual accompanying the compressor.

d. Empty, detached pressure cylinders will normally be sent to the air compressor. When the compressor is located where fuel filling is done, the flame throwers may be serviced as units direct from the compressor.

29. COMMERCIAL CYLINDERS. When air compressors (par. 28.1) are not readily available, the use of cylinders containing nitrogen or air will be necessary.

a. The pressure cylinder * * * procured if obtainable.

* * * * *

d. (Added.) Four fully charged commercial cylinders may charge 26 pressure cylinders; two may charge nine and one may charge three.

32. CHARGING PRESSURE CYLINDERS. This operation is as follows (closing valves hand tight, not using a wrench):

* * * * *

36. CHARGING HYDROGEN CYLINDERS. This operation is as follows (closing valves hand tight, not using a wrench):

* * * * *

52. PREPARATION OF EQUIPMENT FOR STORAGE. Equipment is prepared for storage in the following manner:

* * * * *

c. Remove the fuel * * * vent the tanks. Flush tanks with gasoline, drain tanks, and allow to dry before packing.

* * * * *

f. Remove the battery. Tie battery to gun.

* * * * *
[A. G. 300.7 (15 Mar 44).]

BY ORDER OF THE SECRETARY OF WAR:

G. C. MARSHALL,
Chief of Staff.

OFFICIAL:

J. A. ULIO,
Major General,
The Adjutant General.

DISTRIBUTION:

As prescribed in paragraph 9a, FM 21-6: RH (5); IC 3 (5);
2, 5, 7 (15).

IC 3: T/O & E 3-67, Cml Dep Co; 3-47, Cml Maint. Co; 3-500, Cml
Composite Co.

IC 2: T/O & E 2-27, Rem Trs in Inf Div.

IC 5: T/O & E 5-192, 1 Hqs Co, Engr Combat Gp; 5-225, Prcht AB Engr
Bn, 5-16 Hq Sv Co, Combat Bn; 5-215, Hqs Co, Armd Engr Bn.

IC 7: T/O & E 7-37 Prcht Co (Inf Riflt).

For explanation of symbols, see FM 21-6.

TECHNICAL MANUAL

PORTABLE FLAME THROWERS M1 AND M1A1

CHANGES
No. 2WAR DEPARTMENT
WASHINGTON 25, D. C., 23 February 1945

TM 3-375, May 1943, is changed as follows:

2. GENERAL DESCRIPTION.

* * * * *

f. Duration of fire (Superseded). The portable flame thrower maintains a flame for approximately 8 to 10 seconds, not including time between bursts. The weapon is usually fired in three to five short bursts of from 2 to 3 seconds each to avoid pressure drop and loss of range occurring when the M1A1 portable flame thrower is fired in a longer burst.

* * * * *

2.1. USING GUN OF M2-2 PORTABLE FLAME THROWER (Added). No individual parts of the M1A1 portable flame thrower are interchangeable with parts of the M2-2 portable flame thrower, because of the many differences in design. An M2-2 gun may be used with an M1A1 fuel unit, however, if the following procedure is carried out:

a. Unscrew fuel-hose assembly from M2-2 gun.

b. Screw a $\frac{3}{4}$ - by $\frac{1}{2}$ -inch pipe bushing (gun to hose adapter) into the side opening of the M2-2 gun fuel-valve body. This bushing is furnished in the spare parts kit which accompanies M2-2 portable flame throwers, and in portable flame thrower service kits.

c. Screw fuel-hose assembly of M1A1 portable flame thrower into the $\frac{1}{2}$ -inch opening of the bushing, using a wrench to make a tight connection.

8. PERIOD OF FIRE (Superseded). The limited total length of fire of 8 to 10 seconds for each load of fuel should be kept in mind. The weapon should, if possible, be fired in short bursts of 2 to 3 seconds each. Use of short bursts eliminates sudden pressure drop and loss of range which occur during firing of a long burst of an M1A1 portable flame thrower. Effective use of short bursts also permits engaging a series of targets.

9. RANGE, ELEVATION, AND WINDAGE. *a.* The effective range * * * the flaming fuel.

b. (Added.) Best results are obtained with following winds or very little wind. Strong head winds reduce range. Liquid fuel

AGO 440C—Feb. 622703°—45

should not be fired into head winds of more than 5 miles per hour because some fuel may be blown back toward the firer. Strong cross winds reduce accuracy and range, and tend to break up and disperse the flame from thickened fuels.

c. (Added.) The weapon may be fired at point-blank range (approximately 10 yards) so that almost all the flaming fuel can be accurately directed at great velocity through ports and openings into the target.

d. (Added.) In jungle or thick underbrush without cleared fields of fire, point-blank range is usually necessary in order to penetrate the foliage.

16. AFTER FIRING. When the firer * * * do the following:

a. If another soldier * * * the carrier straps. **Avoid dropping the equipment on the ground as this may damage the weapon.**

* * * * *

17. CLEANING AND REFILLING.

* * * * *

c. Disconnect the hydrogen * * * newly charged hydrogen and pressure cylinders. Do not attempt to use a charge of hydrogen or of compressed air or nitrogen for more than the 8 to 10 seconds' firing time. Not enough pressure * * * the weapon effectively.

* * * * *

17.1. USE OF PACKBOARDS (Added). After firing, it is not necessary to send flame throwers to rear echelons for filling and charging. Quartermaster issue or improvised packboards may be used to bring up supplies to flame throwers; each packboard supplies one flame thrower. The following items are lashed to the packboard: a 5-gallon can, containing 4 gallons of fuel; a charged pressure cylinder; a charged hydrogen cylinder; a wrench with 1-inch opening for the fuel tank plug assembly; and a small adjustable wrench or wrench with $\frac{7}{16}$ -inch opening for the cylinders. Loaded pack weighs approximately as much as a filled flame thrower. Pack permits quick recharging and filling of the flame thrower, without the need for large equipment close to the front line of combat. Manifold cylinders, compressor, and fuel drums are located at the rear filling and charging point to supply the packboards. Only pourable fuel can be supplied in this manner. The emptied pressure cylinder and hydrogen cylinder are lashed to the packboard and returned with the empty fuel can and wrenches to the rear filling and charging point.

18. PRECAUTIONS IN HANDLING.

* * * * *

i. Keep the gun * * * a half hour. In extreme conditions such as landings made through surf, use a rubber or other waterproof cover or bag to inclose either the end of gun (gas burner assembly) or entire gun. If suitable waterproofing material is available, it is very desirable to cover either the entire gun or the front half of the gun, including trigger and spark generator assembly.

* * * * *

21. FORCE PUMP AND FUEL HOSE. Rescinded.

22. ADJUSTMENT OF FORCE PUMP. Rescinded.

23. FILLING THE TANKS. Rescinded.

23.1 FILLING BY PRESSURE (Added). Flame thrower fuel filling kit E6 is used to fill flame throwers quickly with thickened fuel. Operation of this kit is described in TB CW 18.

24. EMERGENCY METHODS OF FILLING. Rescinded.

28. (Superseded.) LIQUID FUELS. a. *Choice of ingredients.* Thin fuels are easy to ignite, but they lack range and are largely burned in flight before reaching target. For this reason liquid fuels should contain the lowest proportion of gasoline and the highest proportion of heavier oils that permit easy ignition. In hot climates less gasoline is needed than in cold climates. Exactness of proportion is not of great importance. Suitable blends are as follows:

(1) By volume, 20 to 25 percent gasoline and 75 to 80 percent light fuel oil. The light fuel oil can be either No. 1 fuel oil, No. 2 fuel oil, Diesel fuel oil, or kerosene.

(2) One part gasoline to four parts of cleaned crankcase drainings. Unused motor lubricating oil can be employed in place of crankcase drainings, but usually it is unavailable for flame thrower use.

b. *Preparation of ingredients.* Before mixing blends, the following steps should be taken:

(1) *Gasoline, Diesel fuel oil, and fuel oils.* These fuels should be allowed to stand quietly for at least 30 minutes to permit any small quantity of water present to settle to bottom. When transferring fuel to another container, remove fuel carefully so that no water is remixed with it.

(2) *Crankcase drainings.* If possible, crankcase drainings should be allowed to stand quietly in a container for at least 1 day. When pouring, take care to prevent the transfer of any of the sludge which may have settled in bottom of container.

c. Equipment. An open-head 55-gallon or 42-gallon drum and an improvised wooden mixing paddle are used. The paddle should be approximately 5 feet long, 2 inches wide, and 1 inch thick. A metal paddle should not be provided because of the danger of striking a spark from the drum. Five-gallon cans may also be furnished for measuring and transferring ingredients. Clean, unrusted, steel storage drums should be at hand. They should be at least 16-gauge to have sufficient strength to withstand the internal vapor pressure of the fuel.

d. Stirring. All the ingredients should be stirred in the drum with the paddle until they appear to form a uniform mixture. This requires approximately 2 minutes.

e. Crankcase-draining blends. If crankcase drainings are used as an ingredient, it is preferable to allow the prepared mixture to settle for 24 hours after stirring, because gasoline in the mixture may cause additional sludge to be deposited. Even after this settling period, it is recommended that the mixture be poured through cheesecloth or some similar fabric before the flame thrower is filled. Crankcase-draining blends should be allowed to stay in the flame thrower only long enough to complete a mission.

f. Transferring. Mixture should be transferred either directly into flame thrower fuel tanks or into storage drums.

g. Emergency mixing in fuel tanks. In an emergency, mixing can be done in flame thrower fuel tanks by adding ingredients in correct proportions, and then shaking or stirring.

h. Testing fuel. Before fuel is used on a mission, it should be tested, if possible, by being fired from a flame thrower.

i. Storage. Fuels may be used immediately after preparation. If the blend contains crankcase oils, fuel should be fired as soon as practicable after filling. Other liquid blends may be stored indefinitely until required for use. For storage precautions see paragraph 45. Storage drums also should be kept tightly closed to prevent loss of gasoline through evaporation, and to prevent moisture from entering the fuel. If stored in the open, drums should be laid on their sides so unit tank contains approximately 4 gallons of fuel. A void of undamaged 16-gauge drum has sufficient strength to withstand the internal vapor pressure of the fuel.

j. Filling flame thrower with liquid fuel. (1) Stand fuel unit up, with fuel tank plug assembly uppermost.

(2) Release any remaining pressure in fuel tanks by opening fuel valve and fuel discharge valve until pressure is dissipated.

(3) Using wrench on plug body, unscrew fuel tank plug assembly.

(4) Using improvised funnel if available, pour fuel into fuel tanks until tanks contain approximately 4 gallons of fuel. Avoid of approximately 2 inches must be allowed above the fuel in the tanks to permit entrance of compressed air or nitrogen.

(5) Wipe threads of opening in fuel tank and threads of fuel tank plug assembly, using clean dry cloth.

(6) Screw fuel tank plug assembly in opening; if plug tends to freeze to seat apply grease general purpose No. 1 (No. 0 if below freezing temperature). Tighten with wrench.

28.1 AIR COMPRESSORS. (As added by C 1.)

* * * * *

c. Instructions on use of the air compressor will be found in TM 3-377.

* * * * *

37. GENERAL. Rescinded.

38. DETAILED DESCRIPTION. Rescinded.

39. PRELIMINARY PREPARATION. Rescinded.

40. BATCH SIZE. Rescinded.

41. MIXING THICKENER AND GASOLINE. Rescinded.

42. LOADING SHIPPING DRUM. Rescinded.

43. AGING. Rescinded.

Figure 32. Apparatus Used for Fuel Mixing. Rescinded.

Figure 33. Measuring Ordinary Gasoline into Mixing Drum. Rescinded.

Figure 34. Weighing NaPalm Thickener. Rescinded.

44. HYDROGEN, NITROGEN, AND COMPRESSED AIR.

* * * * *

n. (Added.) When charging pressure cylinders with compressed air, be certain that no traces of grease, oil, flame thrower fuel, gasoline, or other solvents are present in pressure cylinders, outlets of air compressor, manifold, connections, hose, or commercial cylinders.

o. (Added.) Hands and tools must be free of grease, oil, flame thrower fuel, gasoline, or other solvents when charging, replacing, or servicing flame thrower pressure cylinders or pressure systems.

p. (Added.) If compressed air is used, and if any flame thrower fuel, grease, or oil is detected by sense of sight or smell within pressure cylinders, valves, or accessories, return cylinders or accessories to third echelon for cleaning.

q. (Added.) Keep valve-protective caps on commercial cylinders when in storage and at all other times, except when being used to charge flame thrower cylinders.

r. (Added.) Additional important precautions and information on safe handling of compressed gases are given in TB ENG 39.

51. ADJUSTMENT OF PRESSURE REGULATOR. The pressure regulator * * * adjusted as follows:

a. **Unscrew the fuel tank plug assembly.**

b. (Superseded.) Add 4 gallons of water (or fuel) to the fuel tanks.

* * * * *

52.1. FUEL TANK PLUG ASSEMBLY (Added). *a. Description and functioning.* The fuel tank plug assembly (fig. 40.1) screws into the threaded opening at top of fuel tanks. It provides a safety device which protects the firer; it permits filling and cleaning of the tanks; and it seals the opening when tanks are not being filled or cleaned. Assembly includes—

(1) *Plug body.*

(2) *Lead gasket.*

(3) *Safety head.* This metal part screws into plug body. It prevents the building up of dangerous pressures in fuel tanks (which may be caused by failure of the pressure regulator assembly). Safety head screws into plug body. It includes a soft metal diaphragm which bursts when pressure in fuel tanks exceeds approximately 500 pounds per square inch.

(4) *Deflector tube.* This short, curved piece of 1/8-inch pipe screws into safety head. If safety head should burst and if deflector tube is installed at proper angle (*c* (2) below), tube deflects fuel and pressure away from firer.

(5) *Pipe locknut.* Locknut serves to hold deflector tube at correct angle (*c* (2) below).

(6) *Plug retainer assembly.* This assembly prevents removal and accidental loss of fuel tank plug assembly when filling, cleaning, or inspecting. It consists of a metal rod and chain which are held to the bottom of plug body by a machine screw.

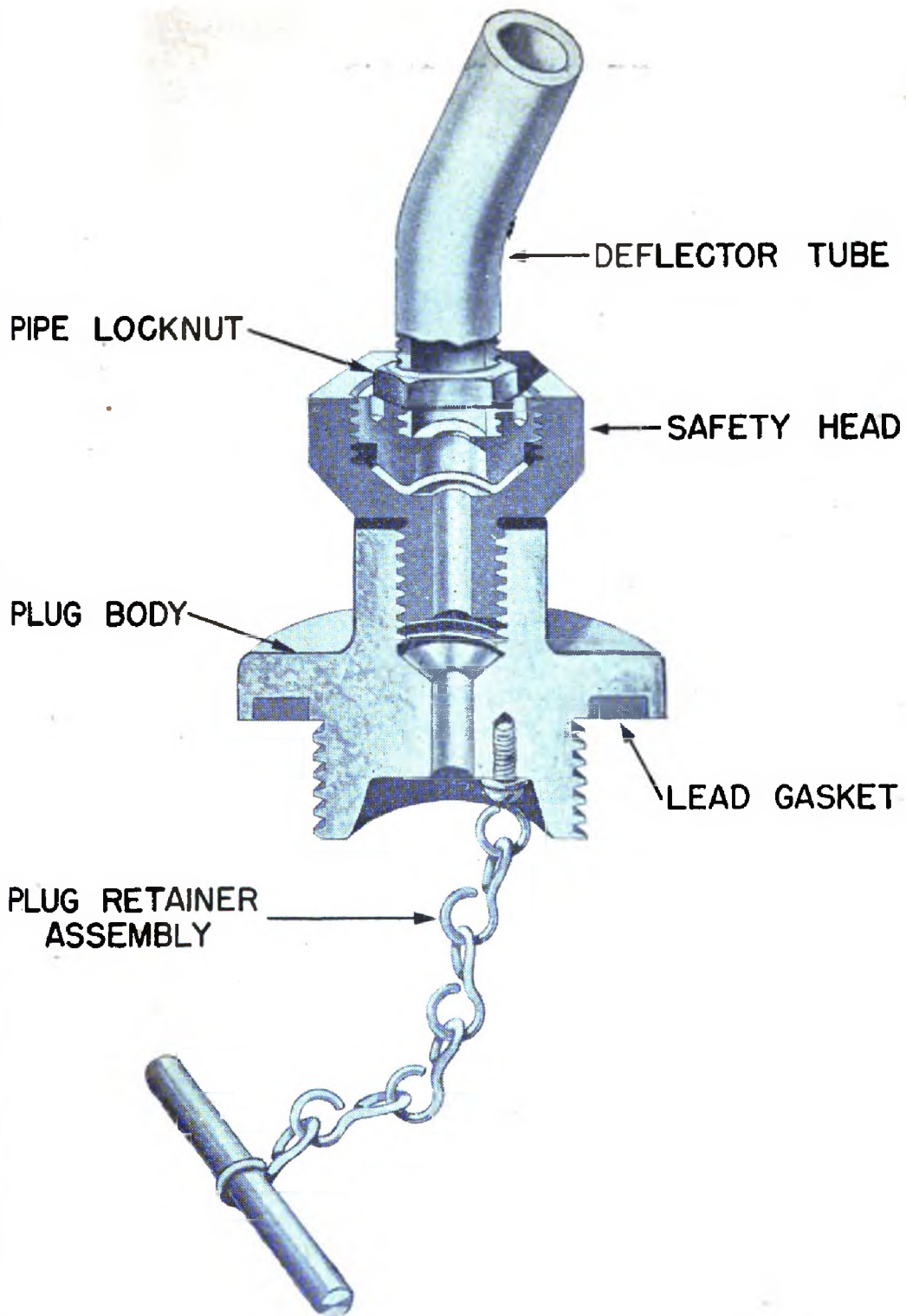

FIGURE 40.1 Fuel Tank Plug Assembly (cross section). Deflector tube must face to rear and at 45° angle to firer's left shoulder. Lock by tightening locknut with wrench.

b. Removal of fuel tank plug assembly. (1) *Precaution.* Before removing assembly or any part of it, operate fuel valve and fuel discharge valve to eliminate any pressure which may have accumulated in fuel tanks.

(2) *Plug body.* To remove plug body, apply wrench with 1-inch opening to square portion of plug body, and unscrew. If it is necessary to lift plug assembly clear of fuel tank, insert bent wire in plug opening and hook the rod of plug retainer assembly, hold rod in a perpendicular position, and lift out complete assembly. Be careful not to mislay lead gasket.

(3) *Safety head.* To remove burst or damaged safety head, do *not* follow procedure in *b* (2) above. Unscrew pipe locknut, using wrench. Unscrew deflector tube by hand. Using wrench, unscrew safety head from plug body. Never disassemble a safety head.

(4) *Plug retainer assembly.* If plug retainer assembly or rod falls into fuel tank, unscrew plug body by applying wrench to square portion. Upend tanks to permit removal of parts.

c. Installation of fuel tank plug assembly. (1) *Plug retainer assembly.* Place unconnected end of chain at screw hole in bottom of plug body. Insert machine screw and tighten with screw driver so chain is held tightly in place on plug body.

(2) *Safety head.* Clean threads with cloth and screw safety head in plug body. Tighten by applying wrench to hex of safety head. Be careful not to touch or strike diaphragm inside head. Never attempt to use a substitute for safety head, which is manufactured to burst at safe limit of pressure, thus preventing an explosion of tanks. Screw locknut on deflector tube by hand; screw deflector tube in safety head by hand. Outlet of deflector tube should face to the rear and at a 45° angle to firer's left shoulder. Tighten locknut with wrench so deflector tube is locked at correct angle. Do not apply wrench to deflector tube.

(3) *Plug body.* With clean cloth, wipe threads of plug body and opening in fuel tank. Place lead gasket over threads on plug body. Insert plug retainer assembly into fuel tank and screw plug body into opening. Tighten, using wrench on square portion of plug body.

d. Maintenance of fuel tank plug assembly. If assembly is damaged or defective, replace parts listed in *a* above, as units. Never attempt to repair safety head or to use an improvised head.

59. GENERAL (Superseded). Portable flame thrower M1A1 is serviced in the field by use of service kit for portable flame thrower M1A1 and E6 fuel filling kit. Contents of service kit are listed in paragraph 61. Contents and operation of E6 fuel filling kit (used to fill flame throwers with thickened fuel) are given in TB CW 18.

60. M1 SERVICE KIT. Rescinded.



HEAD, SAFETY
R81-1-561



UNION, ADAPTER, FEMALE
H98-7-2



BATTERY, IGNITION, 3-VOLT
3A164-9



PLUG, SPARK
A81-1-131



TERMINAL, SPARK
E81-1-86



PLUG, ASSEMBLY



VALVE, TRIGGER, ASSEMBLY
B81-1-15



CAP, FRONT, HOUSING
A81-1-71

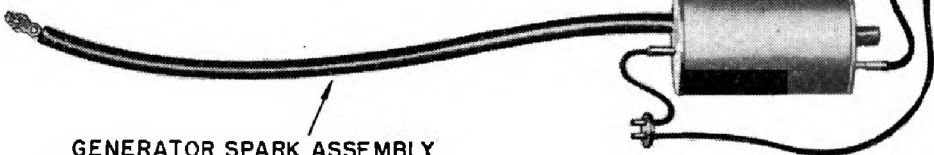

GENERATOR, SPARK, ASSEMBLY
B81-1-77

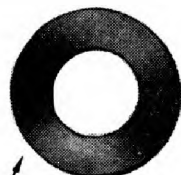

GASKET, LEAD
R81-1-380

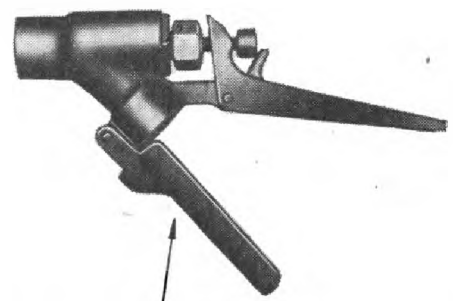

VALVE, FUEL DISCHARGE, ASSEMBLY
C81-1-268



CONDUIT, ELECTRICAL
E81-1-120



HOSE, OIL, ASSEMBLY
E81-1-119



REGULATOR, PRESSURE, ASSEMBLY
B81-1-97

FIGURE 45. Spare Parts Supplied in Kit, Service, for Portable Flame Thrower M1A1.

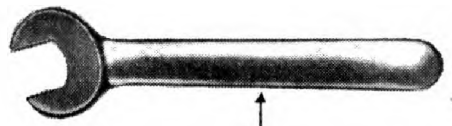

WRENCH, ENGINEERS, 5/16"
H22-49-7

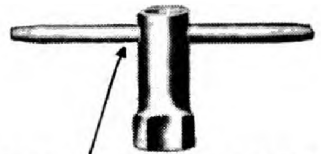

WRENCH, 3/8" SOCKET, ASSEMBLY
E81-6-47

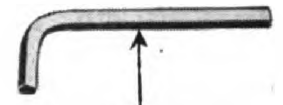

WRENCH, HEX., FOR
H22-49-10, #6 SOCKET HD. SET SCREW
H22-49-11, #10 SOCKET HD. SET SCREW
H22-49-12, #1/4 SOCKET HD. SET SCREW
H22-49-13, #5/16 SOCKET HD. SET SCREW



WRENCH, ENGINEERS, 3/8"
H22-49-8



WRENCH, ENGINEERS, 7/16"
H22-49-9



SCREWDRIVER, COMMON
H22-50-2

10

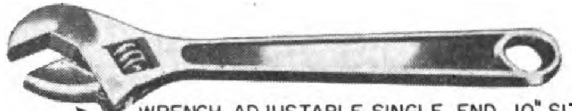

WRENCH, ADJUSTABLE, SINGLE END, 10" SIZE
H22-49-16

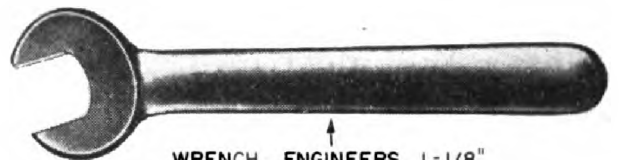

WRENCH, ENGINEERS, 1-1/8"
H22-49-31

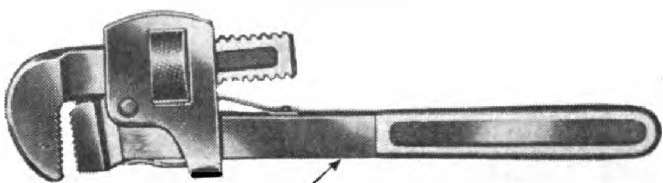

WRENCH, PIPE, ADJUSTABLE
H22-49-15



WRENCH, CONSTRUCTION, 1"
H22-49-14

FIGURE 46. Tools Supplied in Kit, Service, for Portable Flame Thrower M1A1.

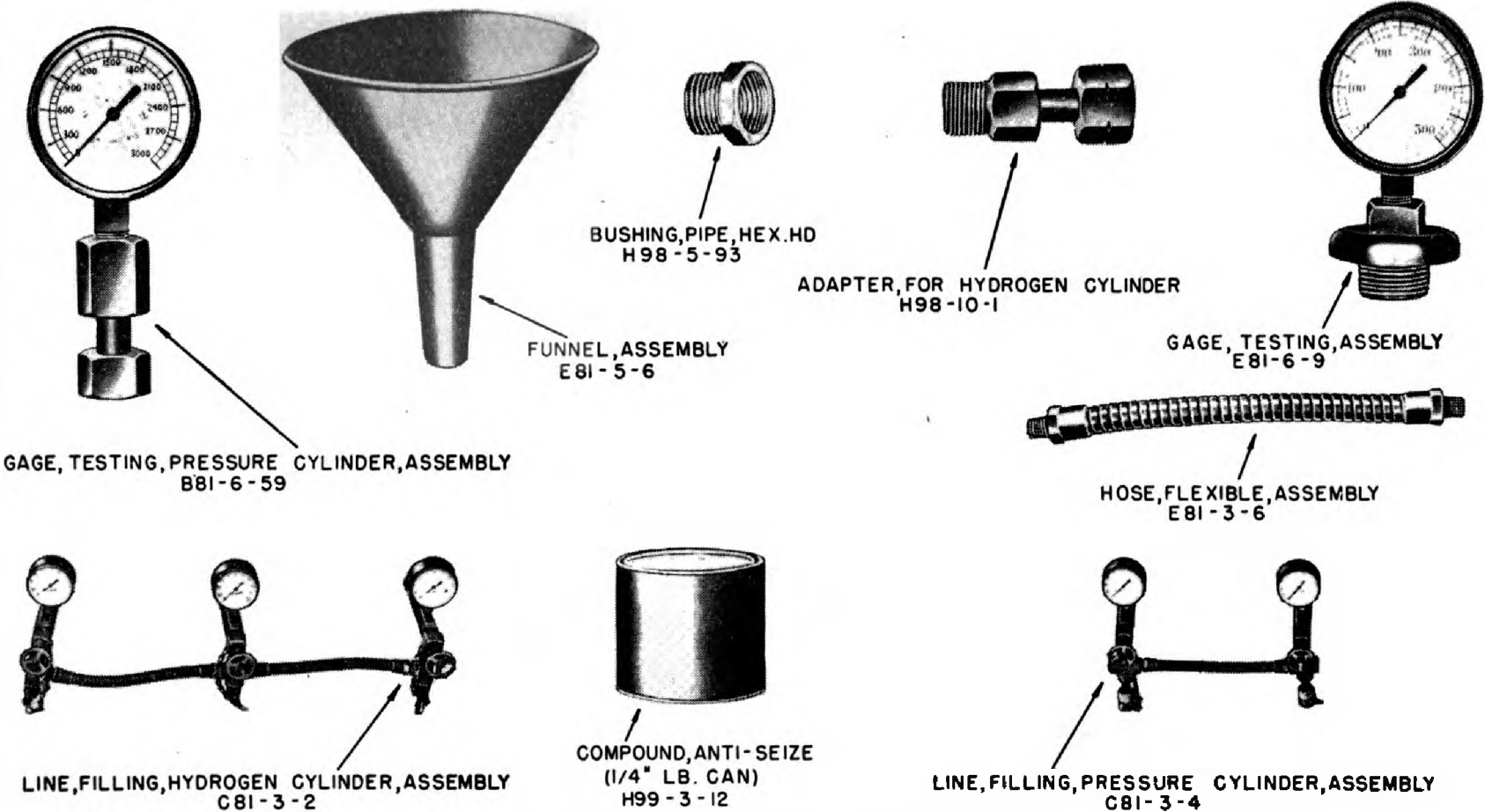

FIGURE 47. Accessories Supplied in Kit, Service, for Portable Flame Thrower M1A1.

Figure 48. Partial Contents of M1 Service Kit. Rescinded.

AGO 440C

11

61. (Superseded.) **KIT, SERVICE, FOR PORTABLE FLAME THROWER M1A1.** Contents of the service kit shown in figures 45 through 47 include the following items:

CWS stock No.	Nomenclature	Quantity per kit
*3A164-9	BATTERY, ignition, 3-volt, 1 $\frac{3}{16}$ " wide x 1 $\frac{3}{16}$ " deep x 2 $\frac{1}{2}$ " high over-all, type 2Z2PI, Burgess Battery Co.	12
A81-1-71	CAP, front, housing	1
E81-1-120	CONDUIT, electrical	1
R81-1-380	GASKET, lead	3
B81-1-77	GENERATOR, spark, assembly	1
R81-1-561	Head, safety (die 603, Black, Sivals & Bryson)	6
E81-1-119	HOSE, oil, assembly	1
A81-1-131	PLUG, spark	6
B81-1-97	REGULATOR, pressure, assembly	1
E81-1-86	TERMINAL, spark plug, assembly	2
H98-7-2	UNION, adapter, female, $\frac{1}{2}$ "-14 NPT x $\frac{1}{2}$ "-14 NPT.	1
C81-1-268	VALVE, fuel discharge, assembly	1
B81-1-15	VALVE, trigger, assembly	1
H22-50-2	SCREW DRIVER, common, normal duty, nominal size 3", width of blade $\frac{3}{16}$ ".	1
E81-6-47	WRENCH, $\frac{3}{8}$ " socket, assembly	1
H22-49-16	WRENCH, adjustable, single end, 10" size	1
H22-49-14	WRENCH, construction, 1" nominal opening x 14 $\frac{1}{2}$ " approx. length, 15° angle.	2
H22-49-7	WRENCH, engineers', $\frac{5}{16}$ " nominal opening, 3 $\frac{1}{2}$ " approx. length, 15° angle, single head.	2
H22-49-8	WRENCH, engineers', $\frac{3}{8}$ " nominal opening, 3 $\frac{1}{2}$ " approx. length, 15° angle, single head.	2
H22-49-9	WRENCH, engineers', $\frac{7}{16}$ " nominal opening, 4 $\frac{1}{2}$ " approx. length, 15° angle, single head.	2
H22-49-31	WRENCH, engineers', 1 $\frac{1}{8}$ " nominal opening x 10 $\frac{1}{2}$ " approx. length, 15° angle, single head.	2
H22-49-10	WRENCH, hex., for #6 socket hd. set screw	2
H22-49-11	WRENCH, hex., for #10 socket hd. set screw	2
H22-49-12	WRENCH, hex., for $\frac{1}{4}$ " socket hd. set screw	2
H22-49-13	WRENCH, hex., for $\frac{5}{16}$ " socket hd. set screw	2
H22-49-15	WRENCH, pipe, adjustable, normal duty, 14" over-all length.	1
H98-10-1	ADAPTER, for hydrogen cylinder	3
H98-5-93	BUSHING, pipe, hex. hd., $\frac{3}{4}$ " x $\frac{1}{2}$ "	6
H99-3-12	COMPOUND, anti-seize, white lead base ($\frac{1}{4}$ lb. can).	1
E81-5-6	FUNNEL, assembly	1
E81-6-9	GAUGE, testing, assembly	1
B81-6-59	GAUGE, testing, pressure cylinder, assembly	2
E81-3-6	HOSE, flexible, assembly	1
C81-3-2	LINE, filling, hydrogen cylinder, assembly	1
C81-3-4	LINE, filling, pressure cylinder, assembly	1
CW6-445103	CATALOG, CW6-445103, Army Service Forces; Kit, Service, for Portable Flame Thrower, M1A1.	2
CW7-440106	CATALOG, CW7-440106, Army Service Forces; Flame Thrower, Portable, M1A1.	2
C81-6-3	CHEST, packing, assembly	1
TM 3-375	MANUAL, technical, TM 3-375; Portable Flame Throwers M1 and M1A1.	2

*Signal Corps stock number.

Figure 49. M1A1 Service Kit, Showing Contents of Tray. Rescinded.

Figure 50. M1A1 Service Kit, With Tray Removed, Showing Filling Manifold Assemblies for Hydrogen and Pressure Cylinders. Rescinded.

Figure 51. Partial Contents of M1A1 Service Kit. Rescinded.

Figure 52. Partial Contents of M1A1 Service Kit. Rescinded.

Figure 53. Fuel Filling Kit, Showing Tray. Rescinded.

Figure 54. Fuel Filling Kit, with Tray Removed. Rescinded.

Figure 55. Partial Contents of Fuel Filling Kit. Rescinded.

Figure 56. Fuel Mixing Kit. Rescinded.

Figure 57. Partial Contents of Fuel Mixing Kit. Rescinded.

62. FUEL FILLING KIT. Rescinded.

63. FUEL MIXING KIT. Rescinded.

65.1. CLASS OF SUPPLY (Added). The portable flame thrower is a class IV supply item.

66. M1 PORTABLE FLAME THROWER. Rescinded.

68. M1 SERVICE KIT. Rescinded.

69. M1A1 SERVICE KIT. Rescinded.

70. FUEL FILLING KIT. Rescinded.

71. FUEL MIXING KIT. Rescinded.

The appendix, Technical Employment, is numbered Appendix I.

APPENDIX II (Added)

LIST OF REFERENCES

1. ARMY REGULATIONS:

AR 850-20, Precautions in Handling Gasoline.

AR 850-60, Compressed Gas Cylinders; Safe Handling, Storing, Shipping, Using.

2. MANUALS:

FM 100-5, Operations.

TM 3-376A, Portable Flame Thrower M2-2.

TM 3-377, Compressor, Air, Gasoline Engine Driven, 7CFM, M1 (For Charging Flame Throwers and Cylinders).

3. TECHNICAL BULLETINS:*

TB CW 18, Kit, Fuel Filling, Flame Thrower, E6.

*Technical Bulletins are to be superseded by appropriate War Department manuals or changes to manuals.

TB CW 20, Cleaning Interiors of Compressed Gas Cylinders, Tanks, and Accessories.

TB ENG 39, Safe Handling of Compressed Gases.

4. ARMY SERVICE FORCES CATALOGS :

CW 7-440106, Flame Thrower, Portable, M1A1.

CW 9-440106, Flame Thrower, Portable, M1A1.

CW 6-445103, Kit, Service, for Portable Flame Thrower M1A1.

CW 9-445103, Kit, Service, for Portable Flame Thrower M1A1.

CW 6-445901, Kit, Fuel Filling, Flame Thrower, E6.

CW 9-445901, Kit, Fuel Filling, Flame Thrower, E6.

CW 7-631110, Compressor, Air, Gasoline Engine Driven, 7CFM, M1.

CW 9-631110, Compressor, Air, Gasoline Engine Driven, 7CFM, M1.

5. FILM STRIPS :

FS 3-21

FS 3-22 } Portable Flame Thrower M1A1.

FS 3-23 }

[AG 300.7 (20 Jan 45)]

BY ORDER OF THE SECRETARY OF WAR :

OFFICIAL :

J. A. ULIO

Major General

The Adjutant General

G. C. MARSHALL

Chief of Staff

DISTRIBUTION :

AAF (Cml O) (4); AGF (Cml O) (10); ASF (2); T of Opns (Cml O) (10); Arm & Sv Bd (1); Def Comd (Cml O) (4); S Div ASF (1); Tech Sv (2) except CWS (45); Sv C (Cml O) (4); PE (Cml O) (2); Sub-PE (Cml O) (1); PG (1); ASF Dep (1); Dep 3 (2); Tech Sv C (1); Gen & Sp Sv Sch (CW Instructor) (2) except CW Sch (10); USMA (1); Tng C (1); A (Cml O) (2); CHQ (Cml O) (2); D (Cml O) (1); B (1); R 2, 7, 17 (2); Bn 2, 7, 17 (2); C 3 (1); two (2) copies to each of the following: T/O & E 3-47; 3-67; 3-117; 3-137S; 3-500. CW Sv Orgn, (AI), (AJ), (BA), (BC), (BD); 5-15; 5-16; 5-17; 5-35; 5-36; 5-37; 5-171; 5-175; 5-176; 5-192; 5-215; 5-216; 5-217

For explanation of symbols, see FM 21-6.

TECHNICAL MANUAL)
NO. 3-375)

PORTABLE FLAME THROWERS, M1 AND M1A1

Prepared under the direction of the
Chief of the Chemical Warfare Service.

	<u>Paragraphs</u>
SECTION I. General	1
II. Description and data	2 - 7
III. Operation	8 - 18
IV. Filling fuel tanks	19 - 28
V. Charging pressure cylinder	29 - 32
VI. Charging hydrogen cylinder	33 - 36
VII. Preparing thickened gasoline	37 - 43
VIII. Precautions in handling materials.	44 - 45
IX. Care and maintenance	46 - 58
X. Equipment and material	59 - 64
XI. Packing, marking, and shipping	65 - 71
XII. Destruction	72
APPENDIX. Technical employment	

*This manual supersedes Training
Circular No. 17, War Department, 1943.

SECTION I

GENERAL

1. PURPOSE AND SCOPE. This manual is intended for the using arms and services. It gives all necessary information regarding the construction, functioning, and identification of all standard materiel pertaining to the portable flame thrower, with directions for operating and servicing such materiel.

SECTION II

DESCRIPTION AND DATA

	<u>Paragraph</u>
General description	2
Fuel system	3
Pressure system	4
Hydrogen system	5
Electrical system.	6
Tank carrier	7

2. GENERAL DESCRIPTION. a. Uses. The portable flame thrower is an offensive weapon of limited use for special situations (see Appendix). Depending upon the tactical situation, it may be used advantageously for:

(1) Assault upon fortifications, such as concrete, steel, timber, and earth emplacements, along with casualty effect on enemy personnel. This is the primary use.

(2) Other uses including:

- (a) Incendiary effect upon buildings, supply dumps, and other inflammable structures.
- (b) Screening effect of smoke produced by liquid fuel.
- (c) Demoralizing effect upon enemy personnel.
- (d) Defense against tanks and in tank hunting.
- (e) Mopping up, forcing of entry, and other purposes.

b. Design. Essentially the portable flame thrower consists of two major sections. These are the fuel unit and the gun unit.

(1) Fuel unit. (See figure 1.) Carried upon the operator's back and supported by straps, the fuel unit consists principally of the following:

- (a) Two fuel tanks, joined together and holding gallons of fuel.
- (b) Pressure cylinder, charged with compressed air or compressed nitrogen to eject fuel from the tanks.
- (c) Pressure regulator, which controls the amount of pressure delivered to the fuel tanks and includes a relief valve.
- (d) Pressure cylinder valve, which releases pressure to the fuel tanks.
- (e) Fuel valve and connectors, which control flow of fuel to the gun.

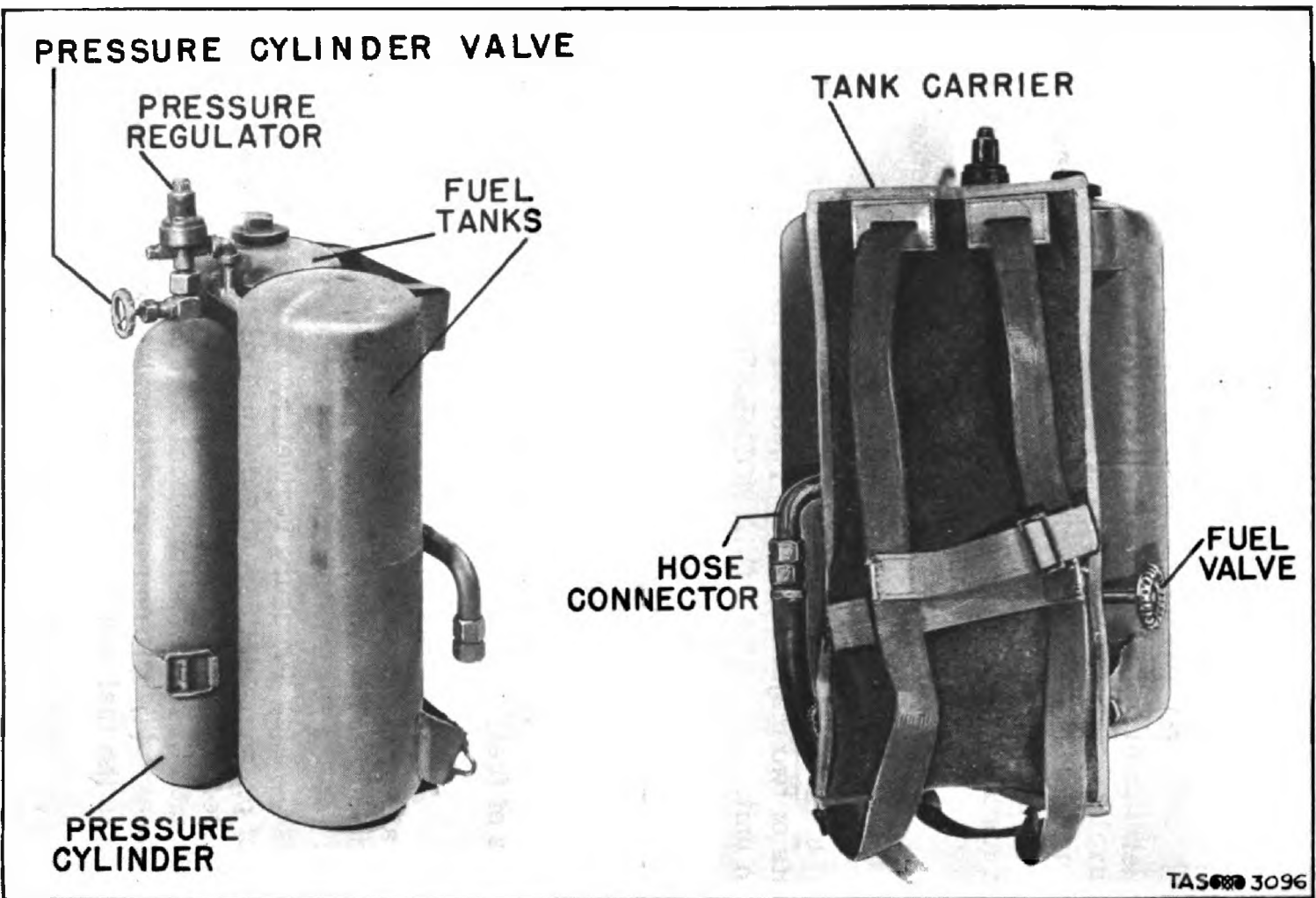

(f) Tank carrier, which supports and secures the unit to the operator's back and shoulders, and includes a pad and straps.

(2) Gun unit. (See figure 2.) Held in the operator's hands and directed by him, the gun unit ignites the fuel and projects it at and upon the target. It includes the following:

(a) A flexible fuel hose which conveys fuel from the fuel unit to the fuel discharge valve.

(b) Fuel discharge valve, which releases fuel to the fuel tube when the flame thrower is to go into action.

(c) Fuel tube, which conveys fuel to the nozzle, and which supports the hydrogen and electrical systems.

(d) Fuel nozzle, which projects the fuel through the gas burner.

(e) Gas burner, a chamber where the fuel is ignited as it passes through it from the nozzle.

(f) Hydrogen cylinder, valve, tubing, and burner lead, which together deliver hydrogen gas to the gas burner.

(g) Spark generator assembly, which supplies electric current to the spark plug.

(h) Spark plug, which ignites the hydrogen, which in turn ignites the fuel in the gas burner.

(i) Trigger assembly, which when pressed releases both electricity and hydrogen for igniting the fuel.

(3) Variations. Portable flame throwers, M1 and M1A1, are equipped with either the bent or the straight fuel

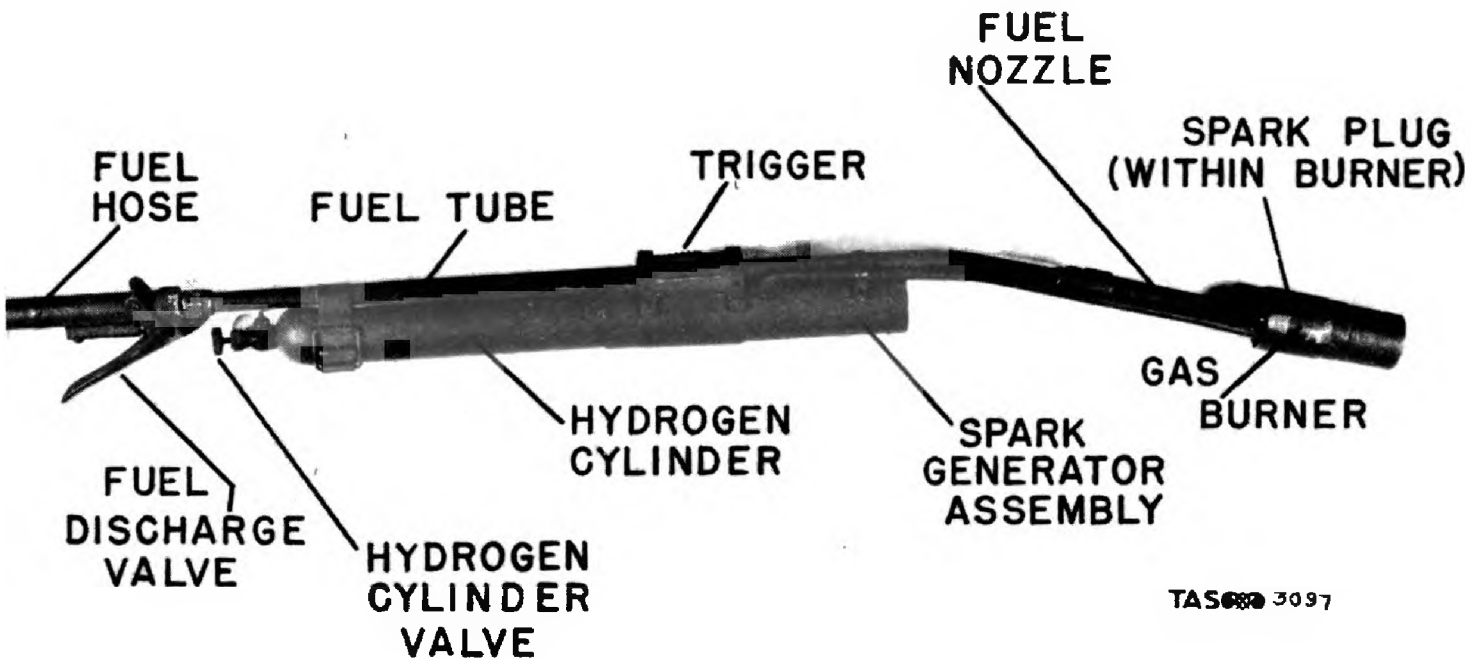

TAS 3097

tube. They originally differed only in the following particular: The M1 flame thrower was designed to use liquid fuels. The M1A1 flame thrower was designed to use any permissible fuel. The M1 type, however, has now been reequipped with the correct fuel discharge valves and pressure regulator parts to enable it to utilize thickened fuel. This reequipment will serve to explain the persistence of the "M1" nameplate upon certain units of materiel now in use.

c. Ranges. A simple adjustment permits the portable flame thrower to utilize either the thickened gasoline or various types of liquid oils and blends. Approximate ranges when using these fuels are as follows:

<u>Fuel</u>	<u>Range in Yds.</u>
Effective, with thickened gasoline	40 to 50
Maximum, with thickened gasoline.	60 to 80
Effective with fuel oil, Diesel oil, light lubricating oil, cleaned crankcase drainings . .	15 to 20

d. Weights. The weight of the flame thrower, both when filled and when empty, is as follows:

<u>State</u>	<u>Pounds</u>
Complete apparatus, empty	32
Complete apparatus, filled (approximate)	68
Fuel unit, complete, empty.	24
Fuel unit, complete, filled (approximate)	60
Gun unit, complete	8

e. Pressures. The following are the pressures recommended for the fuel tanks and the hydrogen and pressure cylinders:

<u>Container</u>	<u>Lbs. per Sq. In.</u>
Fuel tanks.	375
Hydrogen cylinder	1,500 - 2,100
Pressure cylinder	1,800 - 2,000

f. Duration of fire. When discharged, the portable flame thrower will maintain a continuous or intermittent fire for a period of approximately 10 seconds, not including time between bursts.

g. Ratio of expended supplies. For every 100 chargings of the flame thrower, the following supplies are expended:

- 10 - Commercial pressure cylinders (nitrogen or compressed air).
- 2 - Commercial hydrogen cylinders. (3, however, are required on the manifold, but only 2 will be completely expended in charging 100 cylinders.)
- 500 - Gallons of fuel (thickened or liquid).
- 265 - Pounds of NaPalm gasoline thickener, if thickened gasoline is used.

3. FUEL SYSTEM. (Figure 2 and 3) The fuel system stores, supplies, and controls the discharge of thickened gasoline or liquid fuel from the portable flame thrower.

a. Fuel tanks. Two steel fuel tanks comprise the principal parts of the fuel system. Cylindrical in shape and with rounded, closed ends, they have combined capacity of 5 gallons of fuel plus a combined void of 1 gallon. They are tested to withstand a pressure of 625 pounds per square inch. The dimensions of each tank are 19-1/8 inches in height and 6-1/2 inches in diameter. A 1-3/8-inch threaded opening at the top of one tank permits introduction of the fuel.

(1) Fuel tank plug. The 1-3/8-inch threaded open-

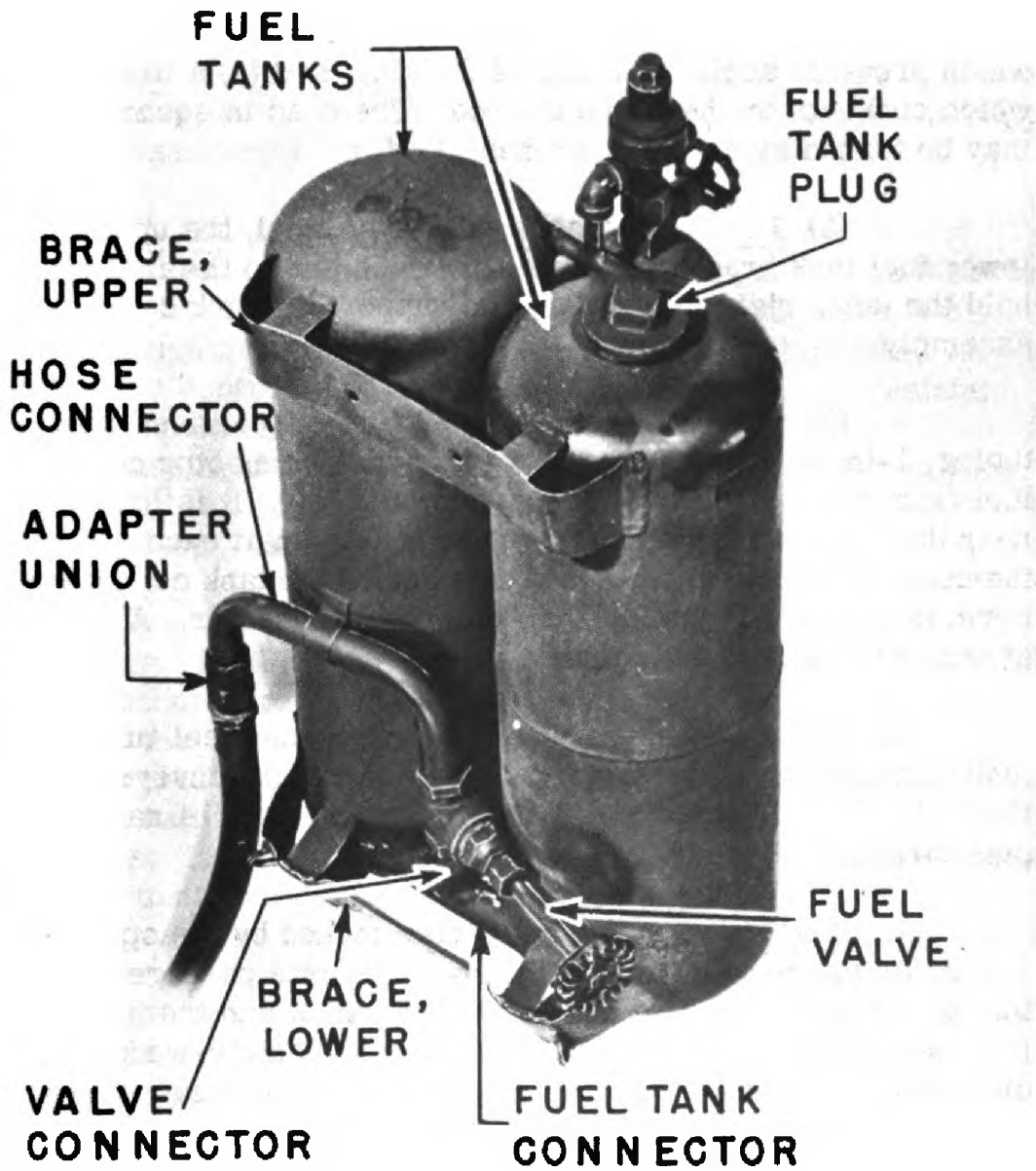

TAS 3098

Figure 3. Part of Fuel System.

ing at the top of one fuel tank is closed, when the unit is not in process of filling or cleaning, by a fuel tank plug. This consists of (1) the head, or plug proper, which screws into the fuel tank opening, (2) a metal rod, which hangs inside the tank and which prevents accidental loss of the plug, and (3) a metal chain which connects the head and the rod. The head is square and may be turned by a 1-inch wrench.

(2) Fuel tank braces. Made of steel, the upper and lower fuel tank braces are welded at each end to the fuel tanks, hold the tanks rigidly together, and support the tank carrier assembly.

(3) Fuel tank connector. Made of seamless steel tubing, 1-inch in outside diameter, the tank connector conveys fuel from the fuel tanks to the valve connector. It is located near the base of each tank and opens into them at each end of the connector. An opening at the center of the tank connector permits passage of the fuel into the valve connector. All joints, at ends and center, are brazed.

b. Valve connector. Made of seamless steel tubing, .840-inch outside diameter, the valve connector conveys fuel to the fuel valve, to which it is joined by a 1/2-inch, 14 national pipe thread.

c. Fuel valve. The fuel valve, opened by the operator just prior to use of the flame thrower, permits passage of the fuel to the fuel hose, the fuel discharge valve, and the fuel tube. It is operated by a hand-wheel, and is of the single-wedge, disk-gate, taper-seat, non-rising stem, inside-screw, screwed-bonnet type. It is joined to the valve connector and hose connector by 1/2-inch, 14 national pipe threads.

d. Hose connector. Made of seamless steel tubing, the hose connector is "C" shaped. It conveys fuel between the fuel valve and the fuel hose, and is supported on one of the fuel tanks

by the hose connector support. The latter is a steel strip, curved to fit around the hose connector, and brazed at each end to the fuel tank.

e. Adapter union. This part, joining the hose connector to the hose, has 1/2-inch, 14 national pipe threads, and permits ready disassembly of the hose from the fuel tank unit.

f. Fuel hose. (Oil hose) The fuel hose provides a flexible connection between the tank unit and the flame thrower gun. Approximately 37-1/4 inches in length, the hose is a flexible synthetic rubber tube and cover of the type used for hydraulic controls. It is gasoline-resistant and oil-resistant, and is capable of withstanding the stress of fuel, under pressure, passing through it. The hose is 1/2-inch in inside diameter and 1-inch in outside diameter. At each end are brass "pressed-on" male couplings with 1/2-inch 14 national pipe threads.

g. Fuel discharge valve. (Figure 4) When firing, this fuel discharge valve is clasped and compressed by the right hand of the operator to release fuel to the fuel tube and nozzle. It is located at the near end of the gun, between the fuel hose and the fuel tube, to both of which it is joined by threaded connections. It is a quick-opening, lever-operated type valve to permit instantaneous release of fuel when it is desired to fire. Two types of fuel discharge valves have been supplied on portable flame throwers. Known as the Y-valve and the "Beattie slide-ball valve," they provide an opening of full pipe diameter and reduce turbulence of the liquid, permitting the use of either thickened gasoline or liquid fuel. The Y-valve is of the plug type, with inlet at an angle of 45 degrees. The "Beattie" valve is of the straight-bodied, ball-type.

h. Fuel tube. (Oil tube) This seamless steel tubing, 5/8-inch in outside diameter, carries the fuel from the fuel discharge valve to the fuel nozzle. It also serves as a support

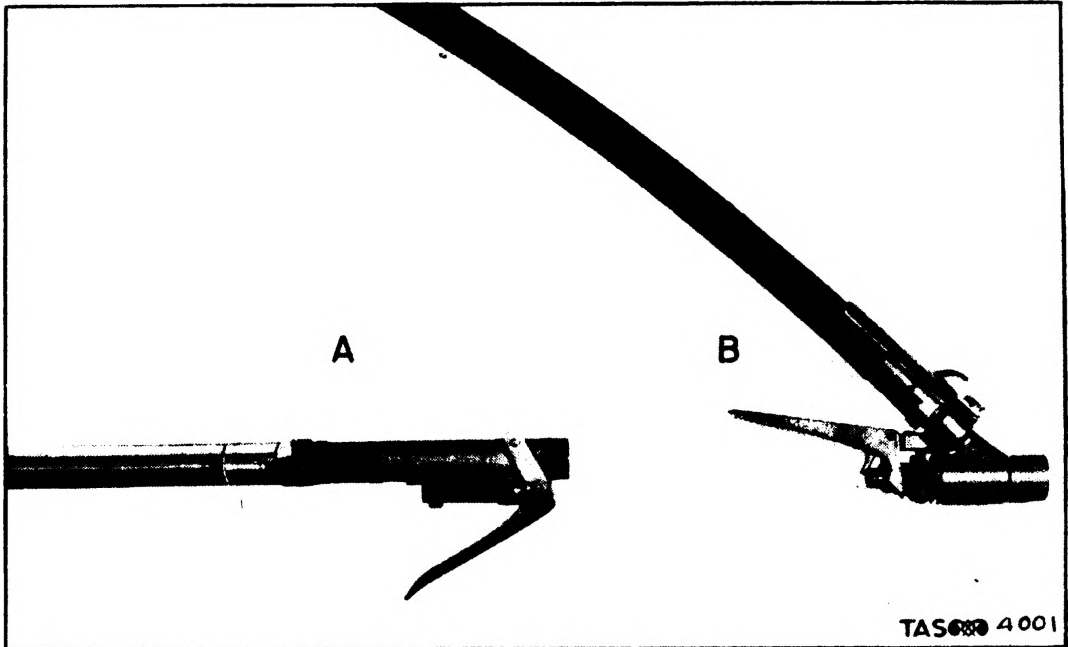

Figure 4. Fuel Discharge Valves. (A) Beattie Slide-Ball Type; (B) Y-Valve Type.

for these and other parts of the gun unit. Its length affords protection for the firer by keeping the flame away from his body. Threads on each end join the tube to the fuel discharge valve and to the fuel nozzle. Fuel tubes of the newer guns are straight; those of older flame throwers are bent downward at an angle of 17 degrees near the fuel nozzle to facilitate firing of fuels other than thickened gasoline.

i. Fuel nozzle. The fuel nozzle ejects fuel under pressure through the gas burner at the far end of the gun. The nozzle is tapered from the fuel tube end to the gas burner end. Inside surfaces of the nozzle are polished to reduce frictional disturbances.

4. **PRESSURE SYSTEM.** (Figure 5) The pressure system, mounted on the fuel tanks, supplies compressed air or nitrogen to the fuel system, making it possible for the fuel to be ejected

forceably from the gun. Before firing, air or nitrogen from the pressure cylinder is allowed to enter and occupy the voids in the fuel tanks. Air or nitrogen is used in preference to other gases because they are easily available and do not readily dissolve in flame thrower fuels. Oxygen must not be used, as a violent explosion may result (see paragraph 29 c). The principal parts of the pressure system are:

a. Pressure cylinder. (Nitrogen cylinder) Largest unit in the pressure system, this cylinder measures approximately 17 inches in length and 3-3/4 inches in diameter. It is made of steel, is tested to withstand 3,000 pounds pressure per square inch, and in use is charged to 1,800 to 2,000 pounds per square inch. It has a capacity of 157 cubic inches. The bottom end is rounded and without openings. The top end has a 1/2-inch 14 national pipe threaded outlet. Cylinders are easily replaced when empty.

b. Pressure cylinder clamp. This device holds the pressure cylinder in place on the fuel unit. It consists of interlocking hinges and permits quick change of cylinders.

c. Pressure cylinder valve. (Nitrogen cylinder valve) Mounted on top of the pressure cylinder and connected directly to the cylinder by a 1/2-inch, 14 national pipe thread, this valve releases and shuts off the flow of compressed air or nitrogen to the fuel tanks. It is tested to withstand at least 3,000 pounds pressure per square inch and is controlled by a malleable iron hand-wheel. The housing and body are of brass. A steel cap protects the outlet threads until the cylinder is ready for mounting on the flame thrower.

d. Pressure regulator assembly. (Figure 6) This apparatus is connected to the pressure cylinder valve by a threaded inlet adapter and nut. The regulator is mounted over the valve, and has the function of reducing the variable cylinder pressure (of 1,800 to 2,000 pounds per square inch) to a con-

PRESSURE REGULATOR



Figure 5. Pressure System.

stant working pressure of approximately 375 pounds per square inch. The pressure regulator assembly includes:

- (1) Body. This comprises the lower part of the housing.
- (2) Spring case. This is the upper part of the housing.
- (3) Inlet adapter nut. This nut has a 3/4-inch, 16 national fine thread on one end and an unthreaded opening at the other end. It is screwed on the pressure cylinder valve and serves to connect it with the inlet adapter.
- (4) Inlet adapter. This brass part houses the compensating spring and metal spider. It also provides a passage for the compressed air or nitrogen from the pressure cylinder valve to the regulator nozzle. The inlet adapter is threaded on the upper end and is attached to the pressure regulator body.
- (5) Inlet screen. To prevent foreign particles from entering the regulator, a wire cloth 150-mesh screen is located on the inner shoulder of the inlet adapter.
- (6) Compensating spring. A steel spring is housed in the inlet adapter, between the inlet screen and the spider. This spring keeps the spider and the operating pin up when the regulator assembly has released sufficient compressed air or nitrogen to the fuel tanks. Also it keeps the spider and operating pin securely seated, and it helps to damper chattering when the regulator is operating.
- (7) Spider. A metal spider is located between the compensating spring, below, and the operating pin, above. It transmits the thrust of the comparatively wide spring to the narrow flare or head of the pin.

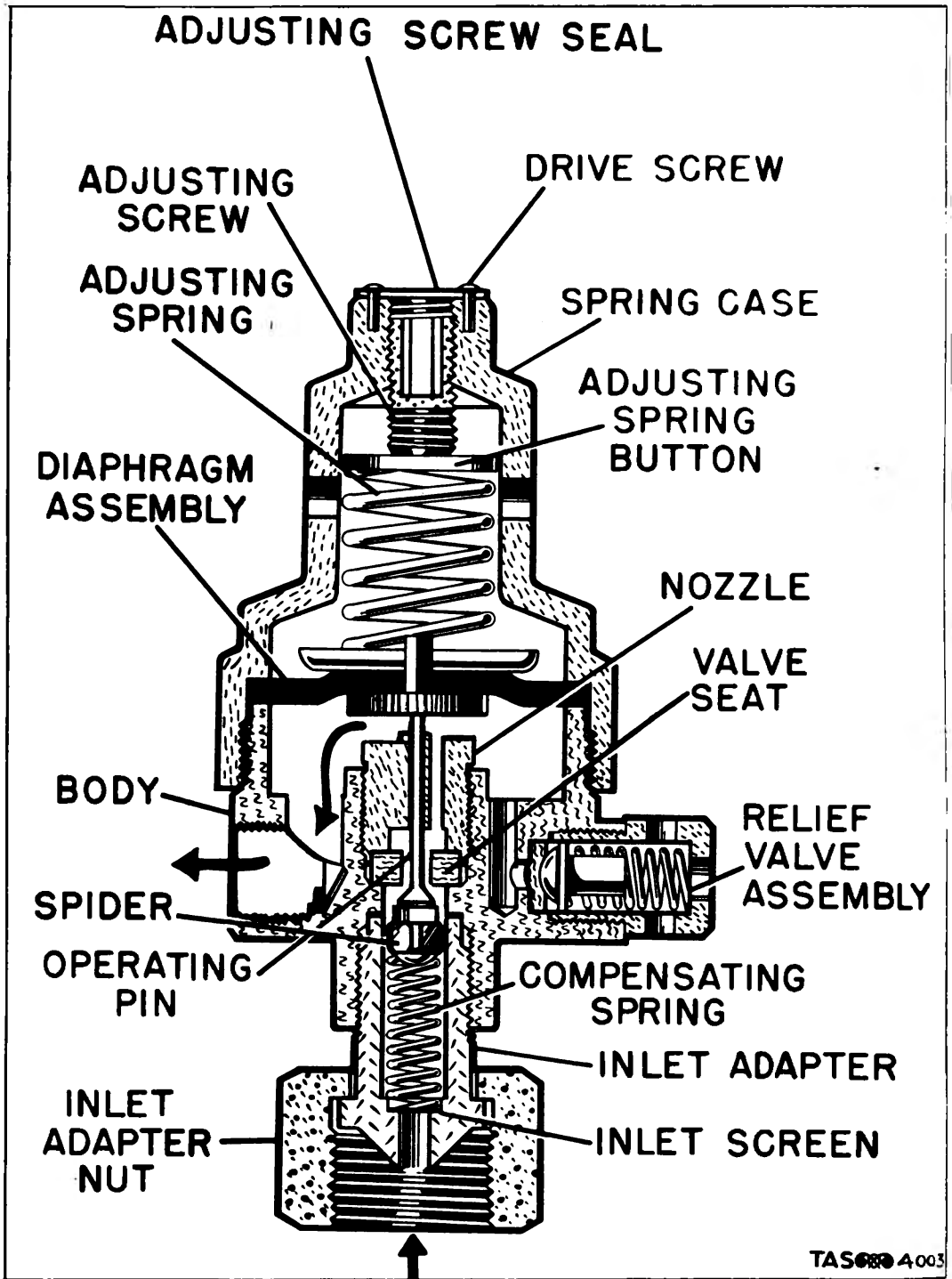

Figure 6. Pressure Regulator Assembly, in Cross Section.

(8) Valve seat. This hard rubber washer has a central hole which permits passage of both the compressed air or nitrogen and the operating pin stem. When the pin is forced up by the compensating spring and spider, this rubber disk forms a seat for the operating pin head, thereby preventing the passage beyond it of air or nitrogen.

(9) Operating pin. This steel pin is flared or headed at one end. The other end is flat and of the same diameter as the stem or body of the pin. This flat end bears against the nozzle plate at the bottom of the diaphragm assembly. The stem passes through the valve seat and the nozzle.

(10) Diaphragm assembly. When air or nitrogen pressure above the fuel in the fuel tanks reaches approximately 375 pounds per square inch, the diaphragm assembly is forced up. This permits the compensating spring, operating stem, and spider to rise and block the valve seat opening, preventing escape of additional air or nitrogen to the fuel tanks. The diaphragm assembly includes a synthetic rubber molding, steel diaphragm plate bonded to the top of the molding, and steel nozzle plate bonded to the bottom of the molding.

(11) Nozzle. This brass, plug-shaped part is threaded externally to fit into the regulator body above the rubber valve seat. The nozzle is drilled through its center to form a passage for the operating pin stem. This passage is not wide enough to permit passage of compressed air or nitrogen. The latter is by-passed through three other holes drilled through the nozzle vertically. Three additional holes, drilled horizontally into the hexagonal head of the nozzle, open into the three vertical holes and provide egress for the compressed air or nitrogen. The air or nitrogen passes into the chamber in the valve body and thence into the diffuse pipe assembly.

(12) Adjusting spring. This steel spring, the largest in the regulator assembly, is located in the spring case, be-

tween the diaphragm and the adjusting spring button. It rests over the projection on top of the steel diaphragm plate. The spring holds the diaphragm down. Its main function is to permit adjustment of the assembly so that the pressure of air or nitrogen released to the fuel tanks will be as close as possible to 375 pounds per square inch.

(13) Adjusting spring button. This steel disk permits the adjusting spring to be tightened by the adjusting screw.

(14) Adjusting screw. This is a 5/16-inch, 18 national coarse 3/4-inch, socket-head, cup-point, hardened-steel, set screw. It may be adjusted by means of the proper set screw wrench to give the desired fuel tank pressure, as described in paragraph 51.

(15) Adjusting screw seal. This brass disk is mounted over the adjusting screw at the top of the pressure regulator assembly. It is held to the spring case by two small No. 00 x 1/4-inch long, round head, drive screws. It prevents tampering with the adjusting screw.

(16) Relief valve. This assembly is built into the side of the pressure regulator. It is set to bleed if pressure in the valve body chamber and the fuel tanks reaches 450 pounds per square inch and to open fully if pressure reaches 500 pounds per square inch. It thus prevents the building up of excessive pressure in the fuel system.

e. Diffuse pipe assembly. This "T"-shaped assembly of seamless steel tubes is a passage for compressed air or nitrogen from the pressure regulator to the two fuel tanks. One tube has a 1/8-inch 27 national pipe thread at one end, whereby it is connected to an elbow and nipple leading from the pressure regulator body. At its other end this tube is welded to the two other seamless steel tubes, each of which leads into one of the two fuel tanks near their tops. Welds also seal the edges of the

penings into the tanks. The portions of the tubes inside the tanks are each perforated in a dozen places to permit ready escape of the compressed air or nitrogen into the fuel tank voids.

5. HYDROGEN SYSTEM. Hydrogen furnishes the flame thrower with a "pilot light," functionally like that of a domestic cooking range. However, the hydrogen does not burn continually. It burns only when the trigger safety key is pressed and pushed forward. This trigger assembly releases hydrogen to the gas burner and almost simultaneously actuates a spark plug which ignites the hydrogen in the gas burner at the far end of the gun. The hydrogen reacts instantly with the oxygen drawn in from the atmosphere, giving a hot, steady flame which in turn ignites the fuel as it emerges from the fuel nozzle. The principal parts of the hydrogen system, all located on the gun unit, are as follows:

a. Hydrogen cylinder. (Figure 2) This steel container, smaller than the pressure cylinder, is mounted on the fuel tube, on its under side, between the fuel discharge valve and the spark generator case. The dome end of the cylinder fits into the socket of the spark generator housing. The open end of the cylinder has a 1/4-inch 18 national pipe thread into which the hydrogen cylinder valve is screwed. For shipping purposes only, a 1/4-inch square-head steel pipe plug is screwed into this opening. The cylinder is tested before shipping at 3,000 pounds pressure per square inch. When the flame thrower is to be operated, the cylinder is charged at 1,500 to 2,100 pounds per square inch. Its capacity is 24 cubic inches.

b. Hydrogen cylinder clamp. This band device holds the cylinder in place on the fuel tube after the cylinder dome has been slid into the hollow of the spark generator housing. It consists of steel hinges, latch, and link, and permits a quick change of cylinders. It also secures the hydrogen tubing (from the hydrogen cylinder valve) in place adjacent to the fuel tube.

c. Hydrogen cylinder valve. This valve has male threads which screw directly into the cylinder opening (figure 2). Its knurled hand-wheel permits release of compressed hydrogen to the trigger valve. The hydrogen cylinder valve, except for steel spindle and hand-wheel nut, is made of brass. Leather packing is used. The male-threaded outlet is on the side of the valve body.

d. Hydrogen cylinder valve cap. This steel cap has a 3/8-inch, 24 national fine 2 thread. It protects the valve outlet when the cylinder is not in use.

e. Hydrogen tubing, steel. A length of 1/8-inch outside diameter, .022-inch wall thickness, seamless steel tubing conveys hydrogen from the hydrogen cylinder valve to the trigger valve. It is held to the side of the fuel tube by the hydrogen cylinder clamp.

f. Trigger assembly. (Figure 7) This assembly, by hand pressure, provides practically instantaneous release of both the stream of hydrogen and the spark to ignite it. Before releasing the hydrogen, however, the hydrogen cylinder valve must have been partly opened and left open to permit hydrogen to enter the trigger valve. (See paragraph 6 a for a description of the electrical portion of the trigger assembly.) By spring tension the trigger is kept in a locked position until the operator presses and slides the trigger safety key forward. This movement permits the key, a notched metal casting, to move off a boss and compress both the hydrogen trigger valve push button and the electrical push button switch. This pressure on the valve push button opens the trigger valve, permitting quick release of hydrogen to the burner. The trigger valve is a small, bronze, high-pressure push button type valve located in a sheet metal housing between the spark generator housing and the hydrogen cylinder valve. Compression-type fittings seal the incoming and outgoing hydrogen tubing that connect the trigger valve with the hydrogen cylinder valve and the gas burner

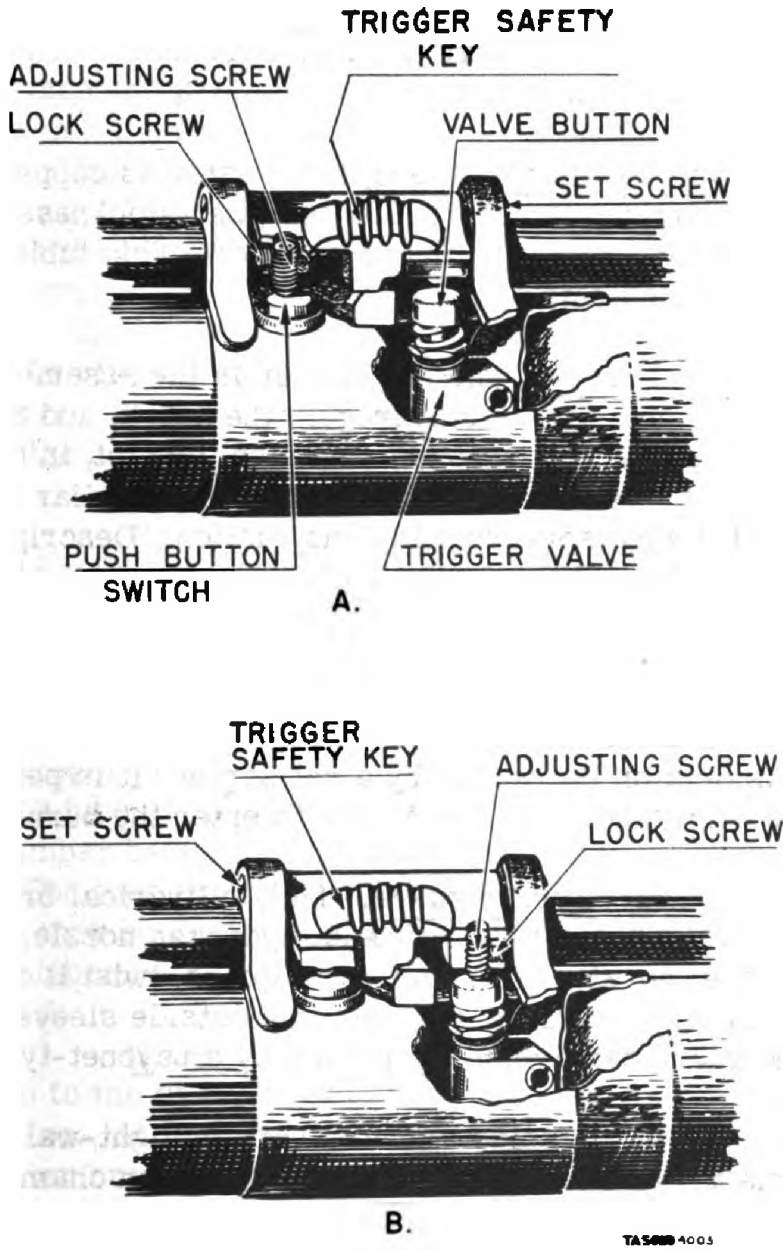

Figure 7. Trigger Assembly, Showing Trigger Safety Key in (A) The Normal Position and (B) The Forward and Depressed Firing Position.

assembly. The trigger valve and connections are made to withstand 3,000 pounds pressure per square inch.

g. Copper tubing. A length of seamless copper tubing, 1/8-inch in outside diameter, .035-inch wall thickness, connects the trigger valve outlet and the gas burner. This tubing is mounted on the outside of the fuel tube.

h. Gas burner. The gas burner is the assembly at the far end of the gun. In it the hydrogen, the spark, and the fuel unite, igniting first the hydrogen and then the fuel, in the presence of air. There are two types of burners, similar in principle, but differing somewhat in construction. Descriptions of each are as follows:

(1) Gas burner, older type. (Figure 8) (a) Guard cap. This brass piece forms the end closure for the burner assembly. The fuel nozzle goes through the center of the cap. The cap is held on the nozzle by a set screw. It is perforated with seven large holes to permit air to enter the burner.

(b) Burner guard. This cylindrical brass housing protects the spark plug and lead, hydrogen nozzle, burner head, and fuel nozzle. To remove the guard, twist it clockwise by hand and slide it off the gun over the outside sleeve. The guard and guard cap are held together by a bayonet-type lock.

(c) Outside sleeve. This straight-walled steel tube forms the outer wall of the fuel combustion chamber. It is brazed at its near end to the burner guard and the burner head, at its far end to the inside sleeve.

(d) Inside sleeve. This steel tubing forms the inner wall of the fuel combustion chamber. It is crimped inward at five regularly-spaced intervals. It is flared outward at its far end and brazed to the outside sleeve. It is brazed at its near end to the burner head. This provides an outer chamber

that surrounds the fuel combustion chamber. This outer chamber is brazed and sealed at both ends except for the aperture through which the length of copper tubing enters this outer chamber. This tubing passes through the outer chamber almost to its far end. There it opens into the outer chamber, releasing unignited hydrogen. The inside sleeve is perforated with 20 small orifices. Each of these orifices releases a jet of hydrogen into the fuel combustion chamber where it is at once ignited by the single flaming hydrogen jet from the burner head and hydrogen nozzle. These 20 flaming jets play on the fuel as it leaves the nozzle, causing the fuel to ignite.

(e) Compression tee and tubing. The compression tee is mounted in the gas burner, except that the inlet compression nut extends out from one of the holes in the guard cap. The tee divides the incoming hydrogen into two streams in fixed proportions. One outlet is a short 1/8-inch outside diameter, .035-inch wall thickness, seamless copper tube leading to the hydrogen nozzle. The other outlet, mentioned in (d) above, is a longer tube of the same characteristics that leads into the outer chamber between the outside and inside sleeves of the burner. The tube extends almost to the far end of this chamber. This tube may be flattened slightly to permit its introduction into the chamber.

(f) Hydrogen nozzle. This brass piece is brazed at one end to the short length of copper tubing from the compression tee. At its other end it is brazed to the burner head. At the latter braze it has the same outside diameter as the burner head. The line of separation of the two parts, therefore, may not be apparent. The projection at the tubing end of the nozzle is counter-sunk and the passage for the hydrogen narrows to a .03-inch passage. This narrow passage increases the velocity of the hydrogen jet and terminates in the burner head. Air is also drawn into the nozzle, from the chamber surrounding the nozzle, through eight holes drilled through the nozzle.

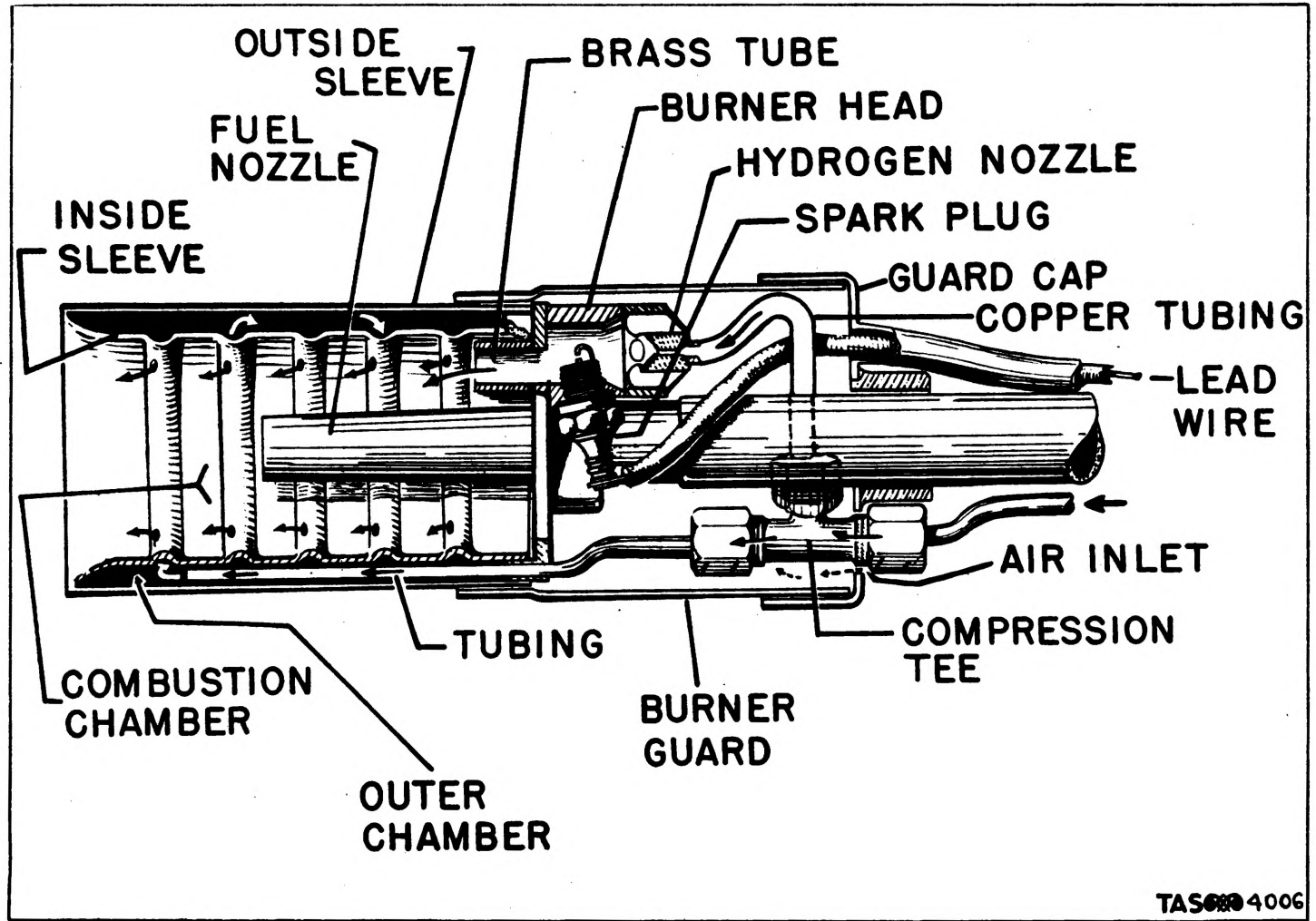

Figure 8. Gas Burner Assembly, Older Type, Cross Section.

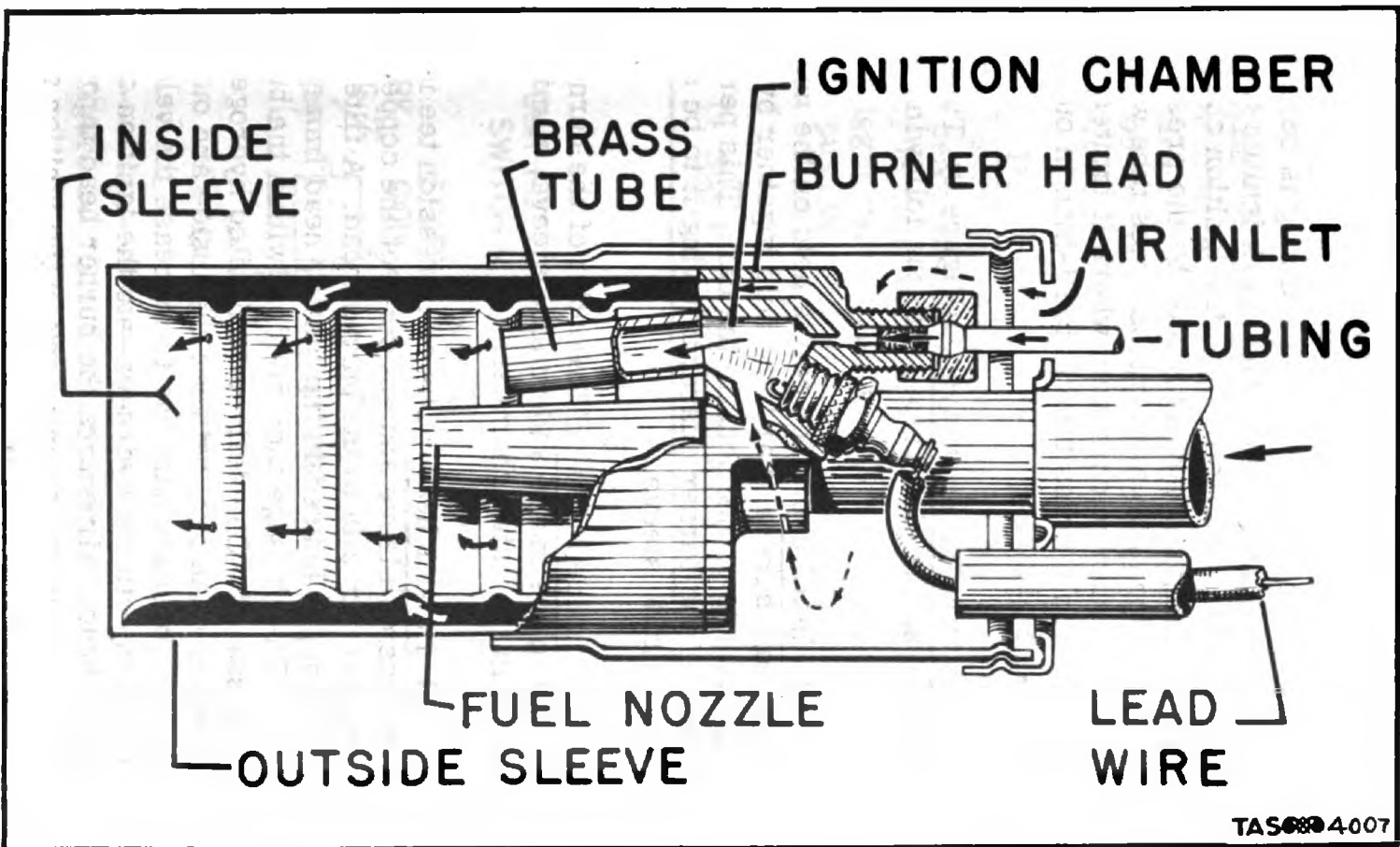

Figure 9. Gas Burner Assembly, Newer Type, Cross Section.

(g) Burner head. The hydrogen and air from the hydrogen nozzle meet in this brass casting, which is brazed to the outside and inside sleeve. The spark plug is screwed into an opening in the burner head. The spark ignites the hydrogen-air mixture as it passes through the ignition chamber in the head. The flaming mixture is forced by the pressure of the compressed hydrogen into a seamless brass tube which terminates in the combustion chamber, where it ignites the flame thrower fuel. This brass tube is 5/16-inch in outside diameter and 3/8-inch long.

(2) Gas burner, newer type. (Figure 9) This assembly is the same as the older type, with the following exceptions:

(a) Guard cap. The cap is held on the nozzle by brazing. The cap and burner guard are held together by a groove in the guard and projections in the cap. This permits quick disengaging of the burner guard, allowing it to be slid off the gun over the outside sleeve.

(b) Inside sleeve. The outlet of the burner head is brazed directly to the inside and outside sleeve, eliminating the copper tubing in the outer chamber.

(c) Burner head. The compression tee is eliminated. A compression sleeve and nut connect the copper tubing from the trigger directly to the burner head. A filter, of copper wire strands, is housed in the burner head immediately beyond the inlet. The passage then divides, within the burner head, into two passages. One delivers unignited hydrogen directly into the outer chamber, between the inside and outside sleeves. The other passage narrows to increase the velocity of the hydrogen, and injects the hydrogen into the ignition chamber, within the burner head. Air enters the burner head through holes drilled at an angle and terminating in the ignition chamber. Thus the burner head takes over the functions of the noz-

zle in the older type of burner. The brass tube exit of the ignition chamber is 1 inch long.

6. **ELECTRICAL SYSTEM.** The intermittent spark that ignites the hydrogen and fuel is furnished by the electrical system (figure 10). This system is part of the gun unit, and is mounted on the fuel tube and burner head. The electrical parts are as follows:

a. Push button switch. The switch that activates the electrical system, releasing the spark, is similar to the ordinary door bell push button. It is depressed when the trigger safety key is slid over and down upon it. The switch is located in the trigger valve housing, as shown in figure 10. Lead wires from the push button connect it to the battery and the spark coil.

b. Spark generator housing. This cylindrical metal

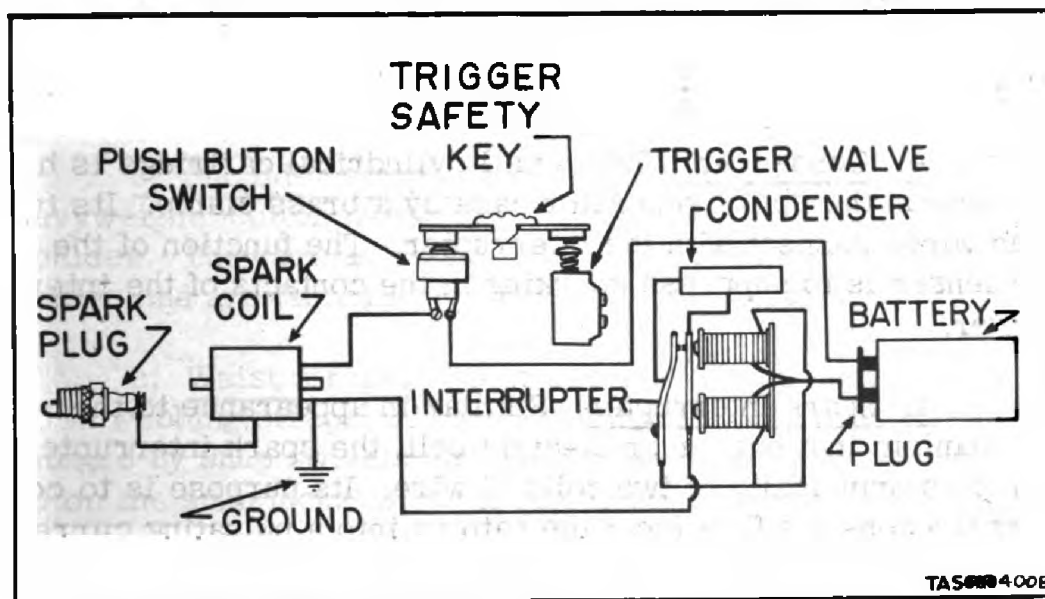

Figure 10. Electrical System, Diagrammatic View.

container with cap is supported under the fuel tube by metal brackets. The back end of the housing adjoins the trigger valve housing. It houses the battery and spark generator case.

c. Battery. The battery provided is a 3-volt dry cell type, with plug connection. The dimensions of the battery are 1-3/16 inches by 1-3/16 inches by 2-19/32 inches. Insulated lead wires connect it to the push button switch and the spark interrupter.

d. Spark generator case. The case is located within the spark generator housing. It holds the spark generator, which includes the interrupter, the condenser, the coil, and the wires that connect them. Two types have been supplied:

(1) Waterproofed cloth, which permits removal and replacement of any of the contents.

(2) A sealed cartridge, of phenol formaldehyde resin impregnated fibre. The cartridge is replaced as a unit, if any of its contents fail, by detaching at the jacks.

e. Condenser. This small cylindrical cartridge is held in place in the spark generator case by a brass clamp. Its two lead wires connect with the interrupter. The function of the condenser is to suppress sparking in the contacts of the interrupter.

f. Spark interrupter. Similar in appearance to the mechanism in a buzzer or electric bell, the spark interrupter consists principally of two coils of wire. Its purpose is to convert the constant flow from the battery into a pulsating current. Its lead wires connect it with the battery and the spark coil.

g. Spark coil. This device steps up the voltage from the incoming 3 volts to an outgoing 5,000 to 6,000 volts. In appearance it resembles a black plastic spool with projections at

each end. The 3-volt current enters through lead wires from the push button switch and the interrupter. One lead is grounded on the flame thrower gun. A high tension lead goes to the spark plug through a conduit of seamless brass tubing.

h. Spark plug. The spark plug resembles an automobile spark plug, but is much smaller, and is of the size and type used in model airplane engines. It is screwed into the burner head. Its size is 3/8-inch hexagonal, with 1/4-inch, 32 thread.

7. **TANK CARRIER.** (Figure 11) This assembly is part of the fuel unit. It supports the fuel tanks, pressure cylinder, pressure regulator, valves, and connectors on the operator's back, chest, and shoulders. The method of carrying is described in paragraph 10. The major parts include:

a. Carrier back. This is a horsehair-filled pad which cushions the load. It is covered with waterproofed, hard texture, cotton duck, or with woolen overcoating, and is fastened by bolts and leather straps to the upper and lower fuel tank braces.

b. Shoulder straps. These are made of 1-1/2-inch heavyweight cotton webbing. There are two, one for each shoulder. They are adjustable by means of tongueless bar buckles and are fastened by snap locks and clasps.

c. Waist straps. These are 1-1/2-inch heavyweight cotton webbing straps, adjusted by tongueless bar buckles and fastened by snap swivels and clasp. The snap swivels are snapped on the snap locks of the shoulder straps.

d. Chest straps. These are two 1-1/2-inch heavyweight cotton webbing straps. One is sewed to the left shoulder strap, the other to the right shoulder strap. They are fastened together by clasps and are adjustable by tongueless bar buckles.

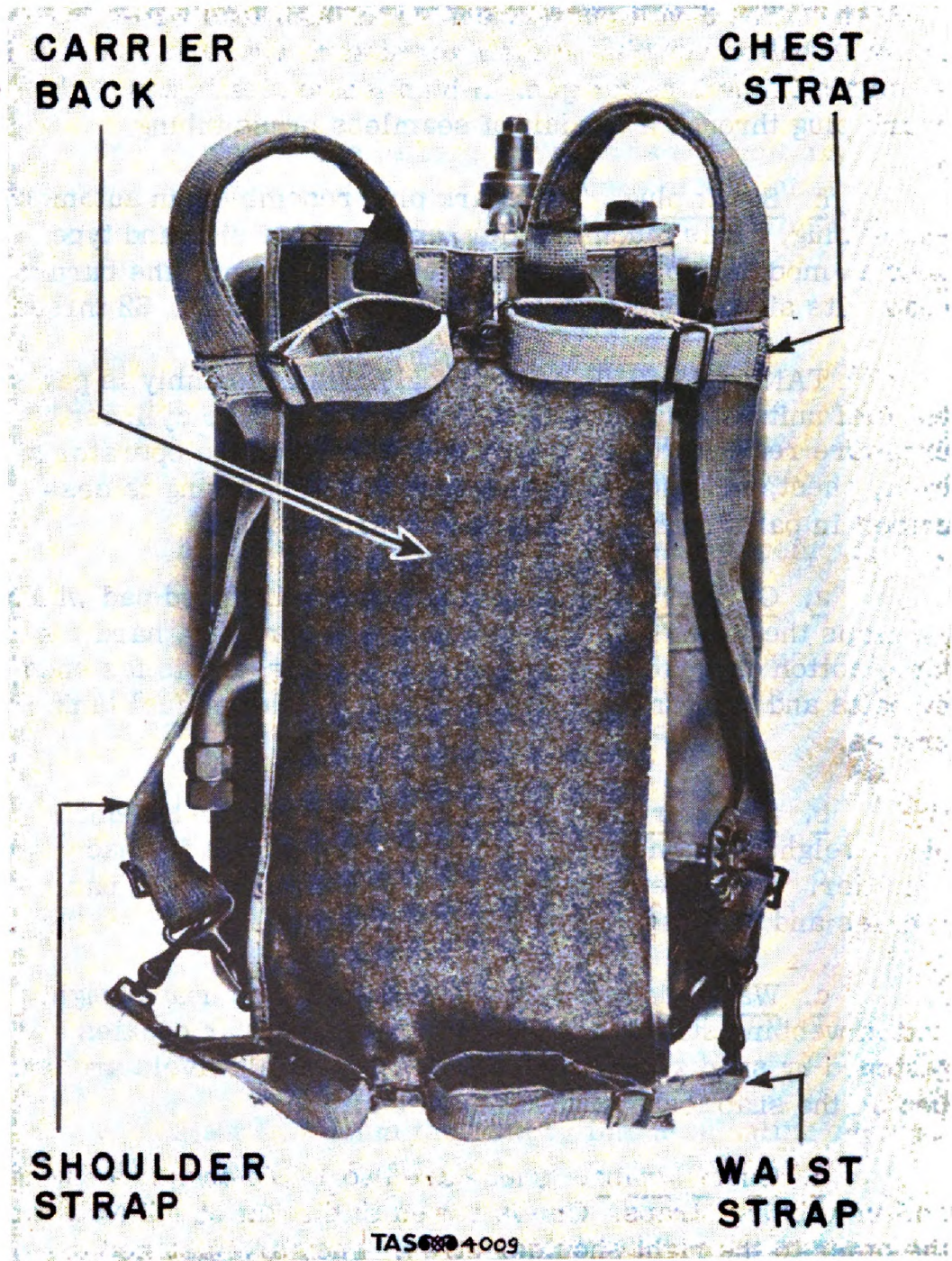

Figure 11. Tank Carrier Assembly.

SECTION III

OPERATION

	<u>Paragraph</u>
Period of fire	8
Range, elevation, and windage.	9
Carrying the fuel unit	10
Carrying the gun unit	11
Preparing to assault.	12
Firing positions.	13
Aiming	14
Firing	15
After firing	16
Cleaning and refilling	17
Precautions in handling	18

8. PERIOD OF FIRE. The limited total length of fire of 10 seconds for each load of fuel should be kept in mind. However, the weapon may be fired effectively in several short bursts that total 10 seconds or less. Short bursts are used when advancing on the target's openings after an initial burst has driven the enemy from the opening.

9. RANGE ELEVATION, AND WINDAGE. The effective range of the flame thrower is 40 to 50 yards under normal conditions, depending on wind direction and velocity, and using thickened gasoline as fuel. Using liquid fuels the range is 15 to 20 yards. The firer should learn to judge whether he is within these ranges before firing at the target. He should practice determining the distance under varying conditions of darkness and light. He should learn also to estimate the angle of elevation of the gun necessary to hit the target. He should be able to make allowances for windage. Wind is an important factor because of the low velocity of the flaming fuel.



Figure 12. Correct Method of Carrying Fuel Unit,
With Weight Distributed on the Straps.

10. CARRYING THE FUEL UNIT. (Figure 12) The fuel unit is supported on the back and secured to it by two shoulder straps, a chest strap, and a waist strap. The carrier back cushions the load. The straps may be adjusted to fit the operator by means of tongueless bar buckles. The shoulder straps pass over the shoulder and under the arm pits. The waist straps are clasped tightly in the front and center of the body. The chest straps, clasped across the chest, help prevent the shoulder straps from slipping and the fuel unit from rolling off the back. Adjustments in the various straps should be made until the unit is carried with the lower fuel tank brace at the small of the operator's back. The fuel unit should fit snugly so that it will not shift when the operator changes from standing to kneeling or prone positions.

11. CARRYING THE GUN UNIT. The firer carries the gun with fuel hose at his right side. He grasps the gun near the fuel

discharge valve with his right hand and near the trigger with his left hand.

12. **PREPARING TO ASSAULT.** When the operator is still afforded protection, the following steps are taken in sequence:

a. Open the pressure cylinder valve. (Figure 13) .This must be done by another soldier, or it must be done before the operator puts the tank unit on his back, because the valve cannot be reached by the firer once the tank unit is mounted upon his back. Be sure to open the valve all the way.



Figure 13. Assistant Opening the Pressure Cylinder Valve Before Operator Is in Position to Fire.



Figure 14. Operator Opening the Fuel Valve Preparatory to Firing.

b. Open the fuel valve. (Figure 14)

c. Open the hydrogen cylinder valve. (Figure 15).
Turn it only about one-eighth turn or slightly less.

d. Press the trigger safety key and slide it forward to find whether hydrogen ignites properly. (Figures 16 and 17)
The hydrogen flame is invisible, but a "pop" may be heard. Do not squeeze the fuel discharge valve until ready to fire and the gun is directed at the target.

13. FIRING POSITIONS. The flame thrower can be fired from any position that permits sufficient freedom to aim the weapon and sufficient stability to withstand the recoil from the gun.

a. Kneeling. Kneeling is the easiest position from which



Figure 15. Opening Hydrogen Cylinder Valve Prior to Firing.



Figure 16. Trigger Safety Key in Safe Position, Before Heel of Thumb Vigorously Strikes and Slides It Forward.



Figure 17. Trigger Safety Key Forced Down and Forward With Heel of Thumb, Actuating Electrical and Hydrogen Systems.

to fire. It is used when considerations of concealment and cover permit. The firer kneels, facing directly to the front, with the right knee on the ground. He should not sit on his right foot or heel, as with a rifle. The left knee is bent so that the left lower leg is nearly vertical. The left forearm rests on the left knee and the left hand supports the gun at the trigger. The right hand grasps the gun at the fuel discharge valve and presses against the firer's right thigh for stability.

b. Prone. (Figure 18) The prone position permits a maximum of concealment and cover under most circumstances. It should not be used however when the firer's head is much lower than his feet. The body should lie with the spine straight. The legs should be well apart, the inside of the feet flat on the ground or as nearly so as can be attained without strain. Elbow should be well under the body. The left hand supports the gun at the trigger. The right hand grasps the gun at the fuel discharge valve.



Figure 18. Prone Firing Position.

c. Standing. The firer leans into the gun when standing. This position is similar in many respects to kneeling, but the left arm is not supported.

14. AIMING. a. Technique. Because of the extremely short range at which it is fired, there are no sights on the flame thrower gun. The gun is not brought to the shoulder but rather held waist or chest high at the right side of the firer. Its angle will depend upon the range. Changes in elevation are made by raising and lowering the right hand. Changes in traverse are made with the left hand. Aim should be as low as is consistent with hitting the target.

b. Training. Precision in aiming is achieved only after much practice. Because of the short firing period there is little or no margin for trial shots, also known as "ranging shots" or "spotting the targets." Because of the low velocity of the burning fuel it may take several seconds for a burst to carry through the air to the target area when firing at or near maximum range. With liquid fuel, the greatest effect is obtained by rolling the flame along the ground up to the target. To do this, the center line of the nozzle should be only one or two degrees above the horizontal at the opening of the burst. With thickened fuel, however, the operator must learn to place the burning burst right on the target.

15. FIRING. (See Appendix.) The following instructions should be followed when firing:

a. Vigorously strike the trigger safety key with the heel of the left thumb, to slide the key forward, and hold it down. (See figs. 16, 17.)

b. When the ignition "pop" is heard and with the trigger safety key still depressed, squeeze the fuel discharge valve handle open with the right hand.

c. Direct the flame at the target, using both hands. Continue to squeeze the key and the fuel discharge valve through the burst.

d. To stop firing, release the key and the fuel discharge valve.

e. Using liquid fuel, it may be desirable at times to soak the target with fuel first and ignite it afterward. To do this, fire two or three bursts without pressing the trigger safety key. Then follow with an ignited burst.

16. AFTER FIRING. When the firer has returned to a relatively safe position, away from the enemy, he should do the following:

a. If another soldier is present, have him close the



Figure 19. After Firing and Returning to a Safe Position, Remaining Fuel Is Blown from Gun Toward Ground.

pressure cylinder valve. Then point the gun downward (figure 19) and blow the remaining fuel, if any, from the flame thrower by pressing the fuel discharge valve, but not the trigger safety key. Remove the fuel unit from the shoulders by unhooking the carrier straps.

b. If the firer is alone he should first remove the fuel unit from his back, then close the pressure cylinder valve and blow the fuel from the flame thrower, as in a above.

c. The hydrogen cylinder valve must next be closed.

17. CLEANING AND REFILLING. a. After use the fuel system must be cleaned, including the fuel tanks, connectors, valves, hose, and tube, by flushing with ordinary gasoline. Use



Figure 20. Cleaning Gas Burner With Cloth After Firing. Entire Inside Must Be Wiped.



Figure 21. Cleaning Each of 20 Orifices of Gas Burner with Sliver of Wood or Iron Wire After Firing.

gasoline, whether thickened gasoline or other fuels have been used. Then wipe any residue from the inside of the burner with a dry cloth. (Figure 20)

b. Clean the 20 burner orifices with a wire or pointed stick. (Figure 21)

c. Disconnect the hydrogen and pressure cylinders at the hydrogen and pressure cylinder connections and clamps. Remove the cylinders for recharging. Install newly charged hydrogen and pressure cylinders. Do not attempt to use a charge of hydrogen or of compressed air or nitrogen for more than the 10 seconds' firing time. Not enough pressure will remain in the hydrogen or pressure cylinder to operate the weapon effectively.

d. Refill the fuel tanks.

e. If the flame thrower is to be temporarily stored, disconnect the gun from the fuel unit (figure 22) by uncoupling the hose and the hose connector. This leaves the hose coupled to the gun but disconnected from the fuel unit. Be sure to clean,



Figure 22. Uncoupling Hose from Hose Connector.

as described in paragraphs 27 and 47.

18. PRECAUTIONS IN HANDLING. (See Appendix) The following precautions are advisable in handling and using the portable flame thrower:

a. Keep all valves closed except when on the alert or when the weapon is actually being fired.

b. Take precautions with regard to fuel, hydrogen, compressed air, or nitrogen, as detailed in Section VIII.

c. In selecting a field in which to fire the flame thrower for training, allow 125 yards for the travel of flames and 20 yards for spread. When firing for training in a field containing dry grass, brush, or near other inflammable material, have available a fire-fighting squad equipped with such materials as wet burlap, brooms, shovels, and other fire-fighting equipment.

d. During training, the operator should wear fatigue clothes.

e. Assistants and personnel observing the flame thrower in operation should stay behind or on the upwind side of the firer.

f. Allow no smoking in the vicinity.

g. When the flame thrower is slung on the back, the operator should keep the gas burner pointed upward and toward the front at all times.

h. Avoid damaging or getting earth into the burner, cylinders, fuel system, and other parts.

i. Keep the gun dry if possible. However, it may func-

tion if exposed to rain of approximately a half hour.

j. Avoid crushing the hydrogen tubing, fuel tube, trigger valves and other parts.

k. Do not fire into too strong a head-wind.

l. When testing, avoid facing the front of the gas burner. The invisible hydrogen flame can cause a severe burn as it emerges from the burner.

m. Empty the fuel tanks, hydrogen, and pressure cylinders before shipping.

SECTION IV

FILLING FUEL TANKS

	<u>Paragraph</u>
Choice of fuel	19
Inspection of thickened gasoline	20
Force pump and fuel hose	21
Adjustment of force pump	22
Filling the tanks.	23
Emergency methods of filling.	24
Care of thickener and thickened fuel	25
Cleaning the force pump	26
Cleaning the flame thrower	27
Other fuels	28

19. CHOICE OF FUEL. (See Appendix) a. Thickened gasoline, prepared as described in Section VII, is often preferred for use in the portable flame thrower. It gives more than twice the range of the liquid fuels, which are described in paragraph 28. In this respect, thickened gasoline affords the mission greater protection against enemy detection and increases the safety of the firer. Liquid fuels give a good smoke screen and a much more brilliant and demoralizing display, as shown in figures 23 and 24, but this means they are largely consumed in the flight to the target. Thickened gasoline, on the other hand, retains more of its effectiveness when it hits the target. The flaming mixture sticks to the target and the clothing and skin of personnel because of its glue-like consistency, and has little or no tendency to roll off. It continues to burn there for several minutes.

b. Before filling the fuel tanks, check whether the pressure regulator is adapted to the fuel.

(1) To burn thickened gasoline, the pressure regu-

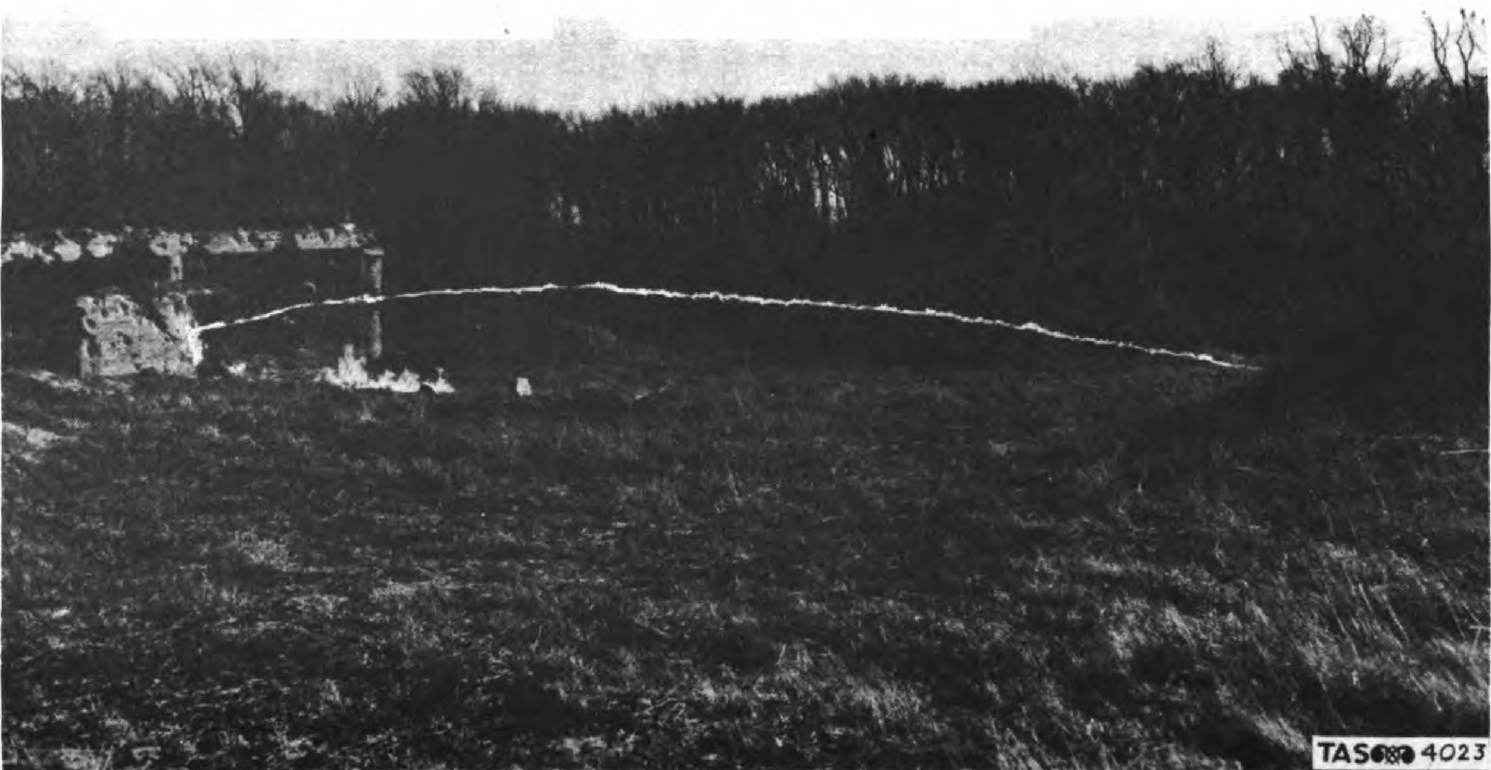

Figure 23. Firing with Thickened Gasoline. Range Is Long and Fuel Burns for Several Minutes on Target.



Figure 24. Firing with Liquid Fuel. Range Is Shorter and Fuel Is Largely Burned in Flight. Screening Effect Is Useful.

lator should be adjusted to 375 pounds per square inch, as described in paragraph 51.

(2) To burn Diesel oils, fuel oils, or blends, including those that contain crankcase drainings, the pressure regulator may be adjusted to 275 pounds per square inch, as described in paragraph 51, but this is not essential as there is very little loss of efficiency at 375 pounds per square inch.

20. INSPECTION OF THICKENED GASOLINE. (Figure 25) To determine when ready for use, the fuel should be inspected for freedom from small lumps. Once these lumps have disappeared they will not develop again. Trapped air bubbles should not be mistaken for lumps. Such bubbles are not harmful; they indicate a rather freshly prepared solution. Samples may be obtained for inspection by pouring from the drum hole or by withdrawing small quantities with a stick or similar device.



Figure 25. Contrasting Newly Mixed Thickened Fuel (Right) with "Aged" Fuel (Left).

21. FORCE PUMP AND FUEL HOSE. The force pump provided is a commercial plunger-type pump with valves and packing of leather or other oil-resistant material. The pump has two outlets: a spout (with screw cap), which is used only as a closure and for priming, and a 1-inch pipe outlet, opposite the spout. This outlet is bushed to 1/2-inch size to accommodate a flame thrower fuel hose (which is used for connecting the pump to the portable flame thrower fuel tanks).

22. ADJUSTMENT OF FORCE PUMP. a. Suction pipe. The force pump is supplied with two different lengths of 1-1/4-inch suction pipe (figure 55). The longer pipe is for use with shipping drums which have the 2-inch hole on the end of the drum; the shorter pipe is for side-opening drums. The appropriate suction pipe should be screwed into the suction hole at the bottom of the pump, a small amount of pipe fitting compound or heavy grease being used on the thread. Care should be taken to prevent pipe compound or grease from getting on the end or inside of the pipe. If available, white lead is used in preference to litharge or grease.

b. Pump rod packing nut. Fuel leaks at the point where the pump rod enters the pump are prevented by fiber packing around the rod. The packing is held in place by a hexagonal nut at the base of the rod. This nut should be screwed in tightly enough to prevent leaks past the rod, but not so tightly as to bind the rod. Occasional adjustment of the packing nut should be sufficient to prevent leaks.

c. Priming. (Figure 26) The pump must be primed with thickened fuel before sufficient suction will be developed to start pumping. It will be most convenient to prime through one of the large discharge openings, rather than through the small vent in the top of the pump. The pump will hold its priming material long enough to permit it to be placed on the shipping drum. To prime, place the pump on its side, remove the discharge spout and pour into it from the drum approximately



Figure 26. Priming the Pump.

a pint of thickened gasoline. Replace the spout and tighten the coupling before using the pump.

d. Discharge line. A 3-foot length of 1/2-inch inside diameter fuel hose (portable flame thrower fuel hose) is connected to the pipe-size discharge opening of the force pump by means of the bushing which is supplied.

e. Connections. The force pump is a pressure device. To prevent leaks and insure proper operation, all connections to it should be tight.

23. FILLING THE TANKS. (Figure 27) The following procedure is recommended when filling the fuel tanks:

a. Install the force pump through the 2-inch opening in the shipping drum of thickened fuel. Check the pump for priming, and prime if necessary.

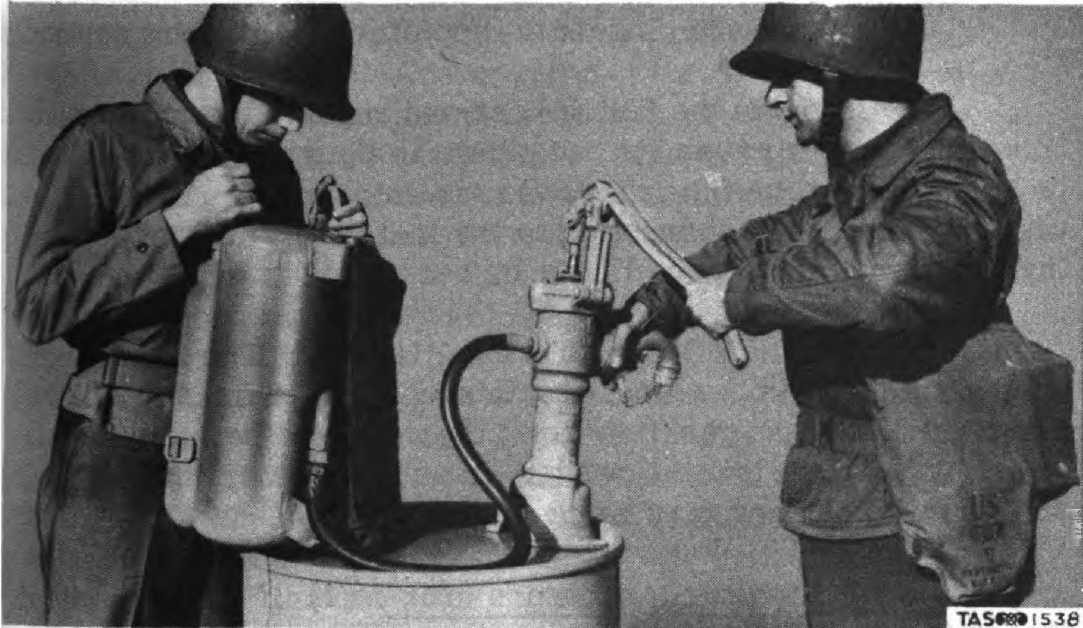

Figure 27. Transferring "Aged" Fuel to Flame Thrower from Shipping Drum.

b. Uncouple the fuel hose and flame thrower gun from the fuel tanks at the union connection between the hose and tanks.

c. Couple the fuel hose from the force pump to the union connection of the flame thrower tank.

d. Remove the fuel tank plug from the top of the flame thrower tank.

e. Open the fuel valve on the flame thrower tank.

f. Pump thickened gasoline into the flame thrower, filling the tank to a level 2 inches from the top.

g. Close the fuel valve on the flame thrower tanks.

- h. Replace the plug on the top of the flame thrower tank.
- i. Uncouple the filling hose and replace the original hose and flame thrower gun, as shown in figure 28. Care should be taken to hold the flame thrower gun in correct firing position while tightening the connection to the fuel tank so that when firing the flame thrower it will not be necessary to twist the hose.

24. EMERGENCY METHODS OF FILLING; The hand-operated force pump is the most practical method of field filling because the thickened gasoline flows too slowly to be readily conveyed by gravity alone. However, in an emergency, the following procedures of filling may be used:

- a. Filling from a pressure drum. (1) If the thickened fuel is in a shipping drum which will stand the required pressure, any available source of compressed air or inert gas may



Figure 28. Attaching Gun to Filled Flame Thrower.

be connected to the drum to force thickened fuel out through a flame thrower fuel line. One opening of the drum is connected through a gate valve to a flame thrower fuel hose. The hose is then attached to the union outlet of the flame thrower for the filling operation. Gas pressure is applied through the second opening of the drum. A pressure of about 40 pounds per square inch is required to force the thickened fuel through the flame thrower oil hose at a reasonable rate.

(2) Only 14-gage steel, or heavier, 55-gallon drums may be used for this purpose. The only drums of United States manufacture which meet these requirements will be stamped "ICC-5," or "ICC-5A," followed by three numbers in sequence. For example, "14-55-42." The number "14" indicates the gage of the metal; "55" indicates the capacity in gallons; and a number such as "42" indicates the year of manufacture (1942). Caution must be exercised to prevent pressure in the drum from exceeding 40 pounds per square inch, otherwise a serious explosion may result. Pressure on such drums should be released as soon as filling operations are completed. Drums should never be moved while under pressure.

b. Filling by hand. If no other means are available for filling the flame thrower fuel tanks, they may be filled by pouring the mixture directly into the filling hole at the top of the tank, using a funnel without a screen.

(1) If this is done with soft, freshly prepared gel, (as would ordinarily be used in filling the shipping drum), the transfer can be accomplished quickly, providing temperatures are below 50 degrees Fahrenheit. However, the fuel cannot be fired from the flame thrower until it has had time to "age." Furthermore, since the thickened gasoline gel will set quickly, this method of transfer requires either that the flame throwers be moved back to a preparing point, or that the fuel be prepared in an advanced position.

(2) If filling is done with the gel after it has set, transfer will require about 1 hour for each flame thrower.

25. CARE OF THICKENER AND THICKENED FUEL. Thickener and thickened fuel must not be allowed to come in contact with any of the following materials which cause partial or complete breakdown: Water, lime, caustic soda, soap, powdered or sheet zinc or lead, lead nitrate, rust preventatives, alcohols, and all acids. Particular care must be taken to keep completely dry both the thickener and all equipment used in handling it. Galvanized vessels must not be used for preparation, transfer, or storage of the thickened fuel.

26. CLEANING THE FORCE PUMP. At the end of each day's use, the force pump should be taken apart and the working parts wiped clean of thickened fuel. Particular care should be taken to clean the valves thoroughly. This will insure correct functioning the next time the pump is used.

27. CLEANING THE FLAME THROWER. a. Tanks. A flame thrower filled with thickened fuel should be placed with the diffuse pipe (which forms the inlet for the compressed air or compressed nitrogen to the tank) uppermost. This minimizes the danger of thickened fuel running into that line. After several fillings, the fuel tanks, connectors, and lines are likely to be coated with a toughened layer of thickened gasoline. This trouble can be detected by failure of the flame thrower to fire all of its charge before blowing gas through the gun. Such unconsumed fuel will soon settle to the bottom of the tanks, which can then be completely drained. The tanks are cleaned by filling them to the top with gasoline, closing loosely, and allowing them to stand in a vertical position in a warm place for several hours. They are then drained. This step should be repeated if necessary.

b. Fuel hose and fuel tube. The inside portions of the fuel hose and the fuel tube may be cleaned by blowing the pres-

sure gas through them, making use of the pressure cylinder and fuel tanks. Because the thickened fuel is thereby sprayed over the inside of the hydrogen burner head, the head must then be wiped thoroughly with a cloth. The small gas diffuser holes in the gas burner should be cleaned with a wire or a pointed match stick.

28. OTHER FUELS. a. When used. When screening effect is of great importance, and closer approach to the target is practicable, fuels other than thickened gasoline may be used. The range, however, is reduced to approximately only 15 to 20 yards, compared with 40 to 50 yards with thickened gasoline.

b. Types. (1) Diesel oils. Medium and heavier grades are preferable.

(2) Fuel oils. No. 1 fuel oil (which is the lightest grade used in domestic oil burners) will have approximately the same flame thrower characteristics as Diesel oil. No. 1 fuel oil is suitable for winter use. No. 2 and No. 3 fuel oils may also be used and are preferred to No. 1 in warm weather.

(3) Blends. Blends are best suited to use over wide temperature ranges. Equal parts by weight of gasoline, kerosene, and No. 6 fuel oil make up the recommended mixture. The gasoline and kerosene may be of any grade available. Another satisfactory blend may be prepared by mixing crank case drainings with sufficient gasoline to give the proper volatility and viscosity. As the used crank case oil will vary widely in characteristics, exact formulae for mixing cannot be given. Ten to 20 percent gasoline by volume often gives good results. Used crankcase oil should be strained through cheesecloth or a No. 30 wire mesh screen before its use in the flame thrower. Crank case oil should not be allowed to remain in the flame thrower long enough for any suspended solids to settle and clog the fuel system.

c. Filling of fuel tanks. (1) Stand the fuel unit up, with the fuel tank plug uppermost.

(2) Using a wrench, unscrew the plug.

(3) Pour in 5 gallons of fuel (approximately 36 pounds), using a funnel if available.

(4) Replace the plug and make tight with the wrench.

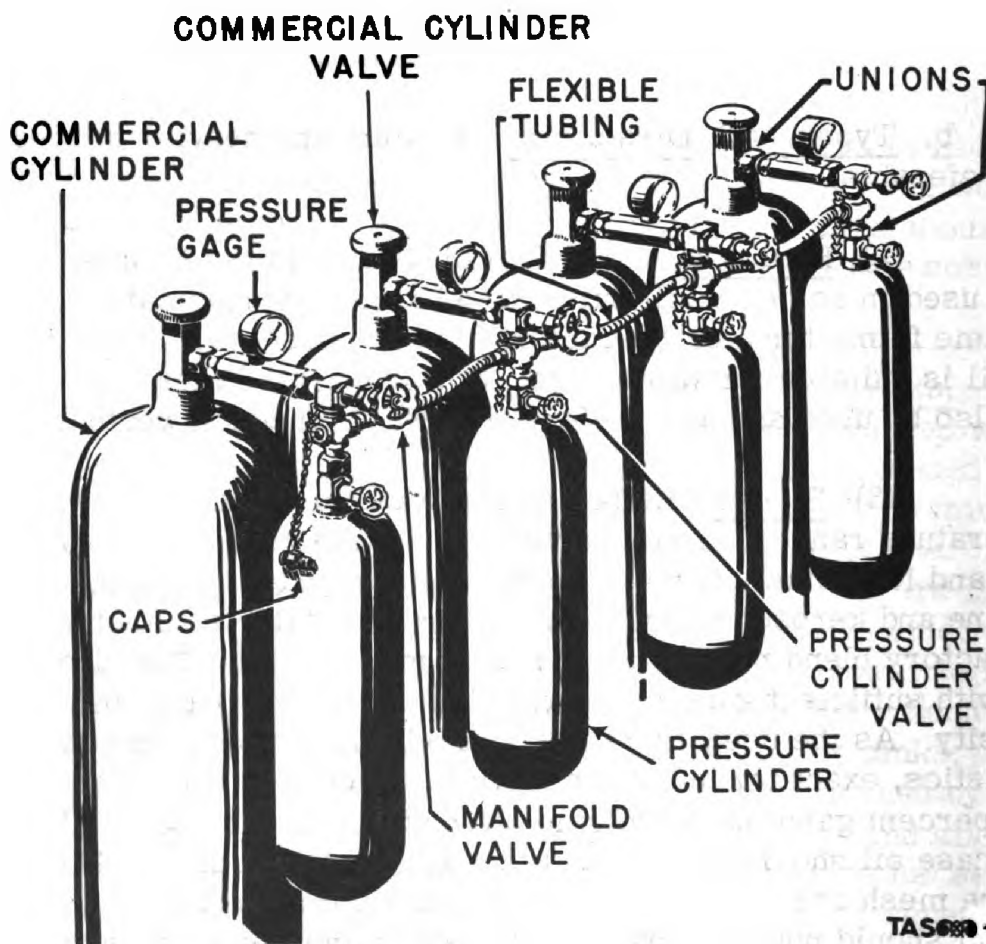

Figure 29. Commercial Cylinders, Pressure Manifold, And Pressure Cylinders, Mounted for Charging.

SECTION V

CHARGING PRESSURE CYLINDER

	<u>Paragraph</u>
General	29
Attaching manifold to commercial cylinder	30
Attaching pressure cylinders to manifold	31
Charging pressure cylinders	32

29. **GENERAL.** a. The pressure cylinder (or nitrogen cylinder) of the portable flame thrower may use either compressed air or nitrogen. Because it is to be filled to nearly the same pressure as that to which a commercial cylinder is charged, it is advisable to charge the pressure cylinder in steps. Commercial cylinders come charged with 200 to 220 cubic feet of air or free nitrogen. Since cylinders with 220 cubic feet of air or free nitrogen will have a higher initial pressure, it is recommended that they be procured if obtainable.

b. The apparatus for charging the pressure cylinder consists of a pressure manifold and commercial cylinders (figure 29). The four couplings are interconnected by flexible metal tubing. A pressure gage and valve are provided for each cylinder. Four unions are furnished for attaching and filling four pressure cylinders at a time. Each union has a cap attached to it by a short chain. These caps are to be used for plugging the outlets when less than four pressure cylinders are to be filled.

c. Warning. Oxygen is sometimes shipped in commercial cylinders having the same threads as commercial nitrogen cylinders. If oxygen not mixed with nitrogen, as in air, is introduced into the fuel tanks of the portable flame thrower, a violent explosion may result. Therefore the greatest care must be exercised to see that only air or nitrogen is used. Before

using a cylinder it should be tested to determine that it is not oxygen. This may be done by introducing a flame into a jet of the contents. Oxygen will cause the burning to take place much more rapidly, while nitrogen will extinguish the flame. To make the test, fasten a thin splint of wood to a wire at least a foot long. Ignite the splint. Hold it before the tank outlet and crack the valve very slightly to permit a small stream of gas to emerge. If the flame flares up, the gas is oxygen and MUST NOT be used. If the gas itself catches fire, it may be hydrogen, acetylene, or some other combustible gas.

30. ATTACHING MANIFOLD TO COMMERCIAL CYLINDER.
This procedure is as follows:

- a. Remove the caps from four commercial nitrogen or compressed air cylinders.
- b. Place the four commercial cylinders side by side with all outlets facing in the same direction. If the ground is not level enough to enable the cylinders to stand up side by side, they may be laid horizontally. In this case all outlets should face up.
- c. Attach a union to each commercial cylinder. Screw the unions down hand-tight. Then, using one wrench on the union body and a second wrench on the nut, tighten the union to make the joint pressure-tight. Do not kink or bend the flexible tubing. Cylinders must be close enough together to relieve the flexible tubing of all tension and strain.

31. ATTACHING PRESSURE CYLINDERS TO MANIFOLD.
The following steps are involved in this procedure:

- a. Remove caps from the pressure cylinders.
- b. Screw the pressure cylinders onto the pressure manifold unions hand-tight. From one to four pressure cylin-

ders may be attached at one time.

c. Using one wrench on the valve body on the pressure cylinder and a second wrench on the union nut, tighten the union to make the joint pressure-tight.

d. If less than four pressure cylinders are to be filled at one time, the unused unions must be plugged with the caps. These are screwed on and tightened in the same manner as the pressure cylinders as described in b and c.

32. CHARGING PRESSURE CYLINDERS. This operation is as follows:

a. Close all four manifold valves.

b. Open valves on the commercial cylinders.

c. Open valves on the pressure cylinders.

d. By means of the gages, determine which commercial cylinder has the lowest pressure. Open the valve on the gage showing the lowest pressure and fill the pressure cylinders to the pressure shown. Close the valve. Then open the valve on the gage showing the next highest pressure and fill the pressure cylinders. Repeat the above steps, ending the filling process with the commercial cylinder having the highest pressure (which must be over 1,800 pounds per square inch).

e. When the pressure cylinders have been filled, close the valves on the pressure cylinders and on the pressure manifold. Remove the pressure cylinders. Repeat steps stated above in a through e with another set of empty pressure cylinders.

f. When the highest pressure shown on the pressure manifold gages is less than 1,800 pounds per square inch, close the manifold valve and the cylinder valve on the commercial

cylinder having the lowest pressure. Remove and replace with a fully charged commercial cylinder. If the pressure on the commercial cylinder removed is less than 500 pounds per square inch, mark the cylinder "Empty" or with the letters "MT." (See figure 30.) If the pressure is more than 500 pounds per square inch, mark the pressure on the cylinder with chalk, so that the remaining gas can be used for some later filling.

g. When filling operations are completed, close the valves on the pressure cylinders and the pressure manifold. Remove the pressure cylinders. Note the pressure indicated on each gage and mark the pressure on each commercial cylinder. Close the valves on the commercial cylinders.



Figure 30. Marking Commercial Cylinder After Its Pressure Is Exhausted.

h. Remove the pressure manifold. Use two wrenches when loosening unions and take care not to twist or kink the flexible tubing. Back off all unions with wrenches to hand-tightness, then release the unions one at a time by hand, supporting the manifold during the operation so that the full weight of the manifold is not allowed to hang on the flexible tubing during removal.

SECTION VI

CHARGING HYDROGEN CYLINDER

	<u>Paragraph</u>
General	33
Attaching manifold to commercial hydrogen cy- linders	34
Attaching flame thrower hydrogen cylinders to the pressure manifold	35
Charging hydrogen cylinders	36

33. GENERAL. a. Flame thrower hydrogen cylinders are filled to nearly the same pressures as commercial hydrogen cylinders. It is advisable to charge the flame thrower cylinders in steps. That is, charge them first from the commercial hydrogen cylinder with the lowest pressure and then charge from a cylinder of higher pressure to bring the pressure up to the requirement.

b. The apparatus for charging flame thrower hydrogen cylinders consists of a pressure manifold and commercial hydrogen cylinders (figure 31). The pressure manifold consists of:

(1) Three unions for the commercial hydrogen cylinders.

(2) Three pressure gages to indicate the pressure in the commercial hydrogen cylinder and in the manifold.

(3) Three valves, one on each union, to admit the hydrogen from the commercial cylinders to the manifold.

(4) Attached to the manifold are three unions for attaching three cylinders to be filled.

(5) The unions are interconnected by flexible metal tubing.

(6) Caps are provided for each union and are to be used when less than three hydrogen cylinders are to be filled at one time.

c. Commercial hydrogen cylinders are supplied in two thread sizes, both left-hand. The manifold unions have a left-hand thread for the larger size. Adapters are provided for converting the manifold to use on commercial cylinders having the smaller size thread.

34. ATTACHING MANIFOLD TO COMMERCIAL HYDROGEN CYLINDERS. This procedure is as follows:

a. Remove the caps from three commercial hydrogen cylinders.

b. Stand the three commercial hydrogen cylinders side by side with all outlets facing in the same direction. If the ground is not level enough to enable the cylinders to stand steady and upright, side by side, they may be laid horizontally. If so, all outlets should face up.

c. Attach a commercial hydrogen cylinder to each commercial hydrogen cylinder union on the manifold. Screw unions down hand-tight. Then, using one wrench on the union body and a second wrench on the nut, tighten the union to make the joints pressure-tight. Keep in mind that threads are left-hand; to tighten, turn wrenches counter-clockwise. In making these connections care must be taken not to kink or unduly bend the flexible tubing. The commercial cylinders must be close enough together so that the manifold can be assembled without putting any stress on the flexible tubing. If threads on the manifold unions do not fit the commercial hydrogen cylinders, the filling operator should attach the adapters described in paragraph 33 c

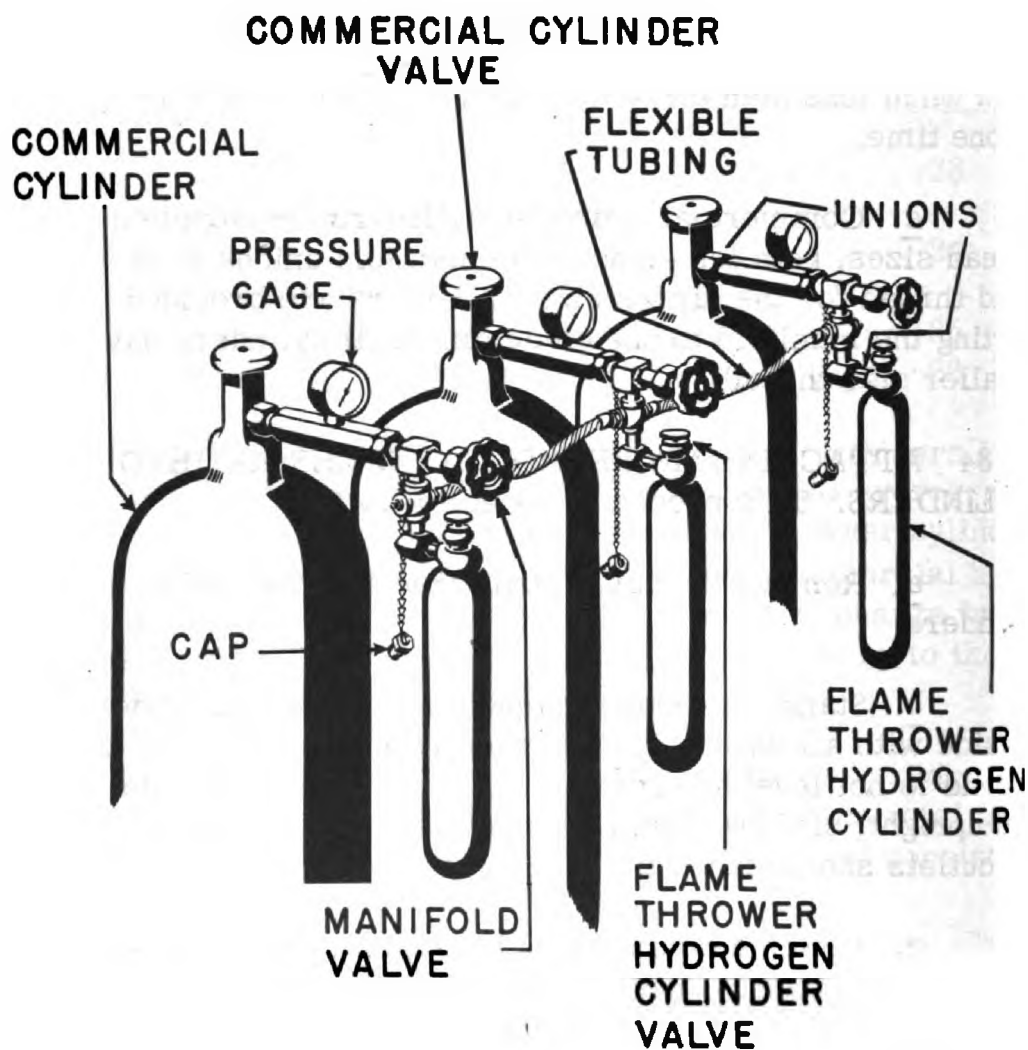

TAS 4025

Figure 31. Commercial Cylinders, Pressure Manifold, and Flame Thrower Hydrogen Cylinders, Mounted for Charging.

to the manifold and proceed as above.

35. ATTACHING FLAME THROWER HYDROGEN CYLINDERS TO THE PRESSURE MANIFOLD. This is accomplished as follows:

a. Remove caps from the flame thrower hydrogen cylinders. (The purpose of these caps is to protect the threads.)

b. Screw cylinders hand-tight onto the unions on the pressure manifold. From one to three cylinders may be attached at one time. If less than three are used, the unused unions must be capped with the cap described in 33 b (6), above.

c. Using one wrench on the body of the valve attached to the flame thrower hydrogen cylinder and a second wrench on the union nut, tighten the unions to make the joints pressure-tight.

36. CHARGING HYDROGEN CYLINDERS. This operation is as follows:

a. Close all three (3) manifold valves.

b. Open valves on flame thrower cylinders

c. Open valves on commercial cylinders.

d. By means of the gage readings, determine which commercial hydrogen cylinder has the lowest gas pressure. Open the manifold valve for this cylinder and fill the flame thrower cylinders to the pressure available from the cylinder having the lowest pressure. Close the manifold valve.

e. If the lowest pressure in the commercial cylinders was over 1,600 pounds per square inch and the pressure after admitting gas to the flame thrower cylinder is over 1,500 pounds

per square inch and up to 2,100 pounds per square inch, close the valves on the flame thrower cylinders, remove the flame thrower cylinders and replace the thread-protecting caps. The equipment is now ready to fill another set of empty flame thrower hydrogen cylinders.

f. If the lowest pressure in one of the commercial cylinders is less than 1,500 pounds, open the manifold valve controlling the cylinder having the next higher pressure. Fill the cylinder and then close the valve. If the pressure in the flame thrower cylinders is still under 1,500 pounds per square inch, repeat, using the third commercial cylinder which must have sufficient pressure to fill the flame thrower cylinders to 1,500 to 2,100 pounds per square inch.

g. When the flame thrower cylinders have been filled to from 1,500 to 2,100 pounds per square inch, close the manifold valves and the valves on the flame thrower cylinders. Remove the latter cylinders and replace the thread protecting caps.

h. When the highest pressure in the three commercial hydrogen cylinders falls below 1,500 pounds per square inch, the cylinder having the lowest pressure should be removed and replaced with a fully charged commercial hydrogen cylinder. Close the valve on the cylinder to be removed, close the manifold valve serving this cylinder, loosen the union connection, remove the cylinder, and replace with a fully charged cylinder. If the pressure in the cylinder being removed is less than 600 pounds per square inch, mark the cylinder "Empty." If the pressure is over 600 pounds per square inch, mark the pressure on the cylinder so that the remaining gas can be used in later filling operations.

i. When filling operations are complete, close the valves on the commercial cylinders and the pressure manifold. Mark the pressure in each commercial cylinder in chalk on the outside of each cylinder.

j. Remove the pressure manifold from the commercial hydrogen cylinders. Use two wrenches to loosen the three unions. Do not kink or bend the flexible tubing. Unscrew the unions by hand, one at a time, supporting the manifold so that the full weight of the manifold is not allowed to hang on the flexible tubing.

SECTION VII

PREPARING THICKENED GASOLINE

	<u>Paragraph</u>
General	37
Detailed description.	38
Preliminary preparation.	39
Batch size	40
Mixing thickener and gasoline	41
Loading shipping drum	42
Aging.	43

37. GENERAL. The process of preparing thickened gasoline consists of mixing NaPalm gasoline thickener with automotive gasoline in an open-head drum and transferring that mixture to a shipping drum before it gels. The apparatus (see figure 32) consists essentially of:

- a. Open-head drum, 55-gallon capacity (not galvanized).
- b. Shipping drum, 55-gallon capacity, with a 2-inch opening (not galvanized).
- c. Portable flame thrower fuel hose, 1/2-inch inside diameter, 3 feet long.
- d. Spring scale, 0 to 30 pounds, graduated in tenths of a pound.
- e. Mixing apparatus, consisting of:
 - (1) Pail, 10-gallon capacity (not galvanized).
 - (2) Two (2) pails, 5-gallon capacity (not galvanized).

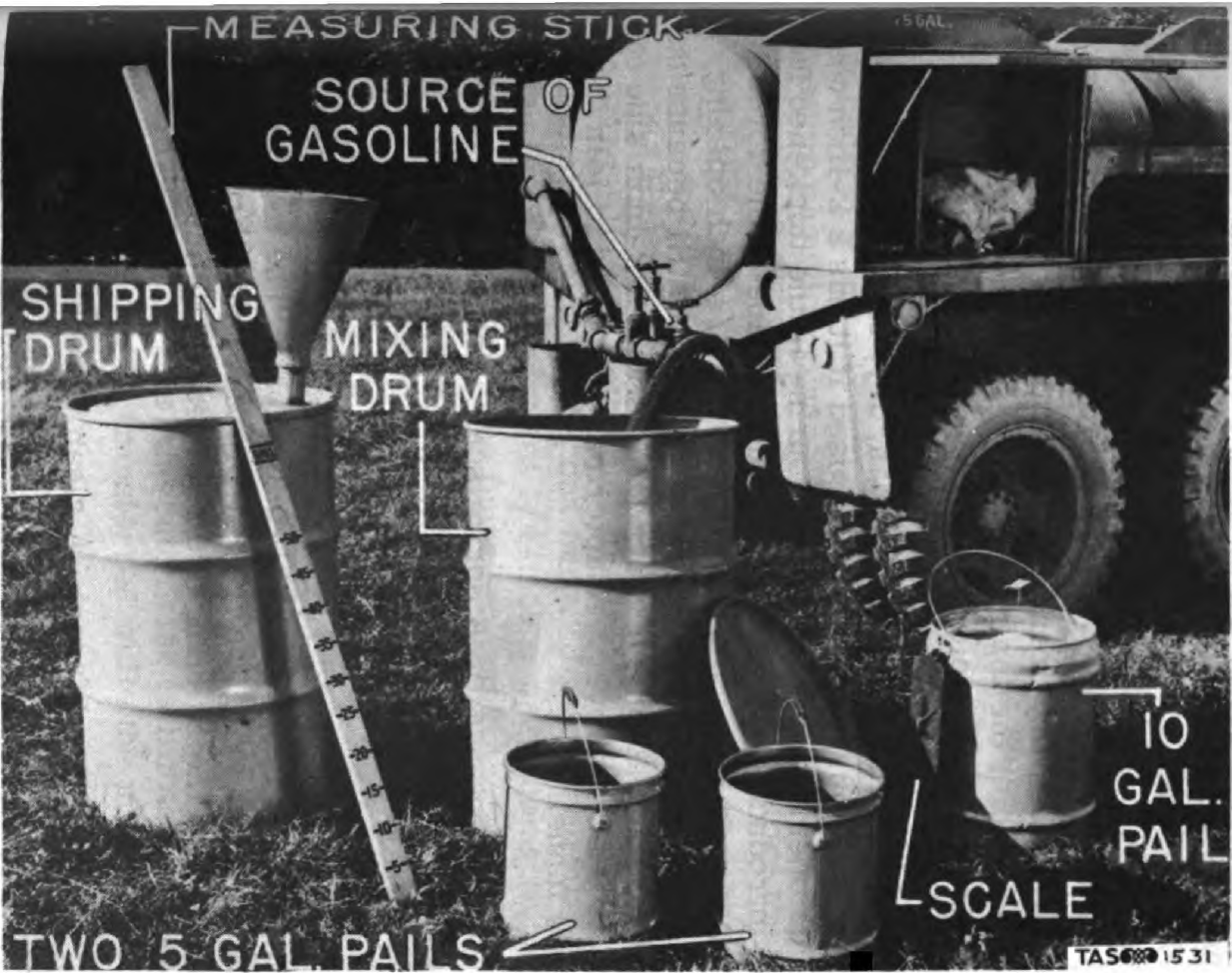

Figure 32. Apparatus Used for Fuel Mixing.

(3) Stirring paddle.

(4) Funnel with 2-inch pipe connection.

f. Vent tube.

38. DETAILED DESCRIPTION. a. Open-head drum. This may be any clean, dry drum that is not galvanized. If no such drum is available, the top may be cut off an empty steel oil drum to provide a suitable receptacle.

b. Shipping drum. Any clean, dry, 55-gallon closed drum of ungalvanized steel may be used if it has a 2-inch opening. This opening is required for pouring in the thickened fuel and for introducing the 1-1/4-inch suction pipe of the force pump. Drums with a 2-inch opening and a 3/4-inch opening, both on one end, will be the most convenient to fill because the 3/4-inch opening acts as a vent. Drums with a 2-inch side opening can be used, however. Adapters are supplied to join the drum and funnel.

c. Spring scale. A spring scale, graduated in tenths of a pound, and capable of measuring up to 30 pounds, is used to weigh out the gasoline thickener.

d. Pails, 5 and 10 gallons. The granulated gasoline thickener is weighed into the 10-gallon pail. The 5-gallon pails are used for conveying the freshly prepared mix through the 2-inch funnel into the shipping drum. These pails must not be galvanized.

e. Paddle and funnel. A clean wooden paddle, approximately 6 feet long, 2 inches wide, and 1 inch thick, is used to keep the mixture of thickener and gasoline agitated during preparation until the thickener no longer tends to settle to the bottom. The funnel is used in the 2-inch opening of the shipping drum to expedite transfer of the freshly prepared solution.

39. PRELIMINARY PREPARATION. a. Precautions in preparation of thickened gasoline. It is of the greatest importance that no water come in contact with the raw gasoline, thickener, or the finished mix. Water will break down the gel and thereby reduce the range of the flame thrower. All equipment therefore must be kept dry. The container of thickener should not be opened until immediately before use.

b. Arrangement of equipment. The shipping drum should be placed in position for filling with mix. The funnel should then be inserted in the 2-inch bung hole. The air vent in the drum should be open, and the 5-gallon pails dry and ready for use in bucketing the mix into the drum. The mixing and shipping drums should be placed so that the mix may be conveyed from one to the other conveniently and quickly before the fresh mix has set.

c. Venting the shipping drum. The drum must be vented while being filled. If both holes are located at one end, it can be vented by opening the second bung. If the 2-inch filling opening is on the side, a length of 1/4-inch copper tubing (funnel vent) is inserted through the funnel so that both ends of the tubing are free of thickened gasoline. Vented gas passes through the tubing when thickened fuel is poured through the funnel.

40. BATCH SIZE. a. Effect of temperature. (1) The temperature of the gasoline will determine the speed at which the mixture sets when thickener is added. Because all of a given batch must be transferred from the mixing drum to the shipping drum before the mix sets, the batch size is limited by the amount of material which can be transferred while the mix is sufficiently fluid to flow readily.

(2) The stiffening rate of mix may be estimated from the following table:

- At 90 degrees Fahrenheit, mix stiffens in 30 seconds.
- At 73 degrees Fahrenheit, mix stiffens in 1 minute.
- At 52 degrees Fahrenheit, mix stiffens in 5 minutes.
- At 31 degrees Fahrenheit, mix stiffens in 50 minutes.

(3) At 95 to 100 degrees Fahrenheit the mix will stiffen extremely rapidly, but it still may be possible, by rapid movements, to transfer it to the shipping drum before it sets. The setting time varies from batch to batch. A trial should be made to determine the size of batch which can be handled at these elevated temperatures. If the gasoline is above 100 degrees, however, transference is no longer possible, as the mix gels almost instantly. After the mix has set, it will still flow through the funnel but at a very slow rate.

(4) Experience will indicate what size batch can best be mixed at a given prevailing temperature, but as a preliminary guide the following table is suggested:

<u>Gasoline temperature</u> (degrees Fahrenheit)	<u>Maximum size of batch</u> (gallons)
90 - 100	10
73	20
52	50
31	50

b. Proportions. Thickened fuel is 8 percent by weight NaPalm gasoline thickener and 92 percent automotive gasoline. The following table shows the weight of gasoline thickener to be used with various quantities of automotive gasoline in preparing such a mixture:

<u>Gasoline</u> (gallons)	<u>Gasoline thickener</u> (pounds)
50	26.3
45	23.6
40	21.0
35	18.4
30	15.8
25	13.2
20	10.5
15	8.0
10	5.3

Allowance of 1/10-pound plus or minus is permissible in weight of gasoline thickener used in the above mixtures. The gasoline thickener is sometimes supplied in packages of 5 pounds, 4 ounces, which is the correct amount to be added to 10 gallons of gasoline. When this packaging is available no weighing of thickener is necessary. One package of thickener is added to each 10 gallons of gasoline.

c. Rough measurement of gasoline. (Figure 33) The mixing paddle may be calibrated to serve as a measuring stick for the gasoline. The following table shows the capacity in gallons, in terms of inches-depth of liquid, for a standard 55-gallon steel drum standing on one end. It is based on a drum internal diameter of 22-7/16 inches, which corresponds to a capacity of 1.7 gallons per inch of height.

<u>Gallons</u>	<u>Inches</u>
50	29-3/8
45	26-7/16
40	23-1/2
35	20-9/16
30	17-5/8
25	14-11/16
20	11-3/4
15	8-13/16
10	5-7/8
5	2-15/16



Figure 33. Measuring Ordinary Gasoline into Mixing Drum.



Figure 34. Weighing NaPalm Thickener.

41. MIXING THICKENER AND GASOLINE. a. The correct quantity of NaPalm gasoline thickener, as indicated above, is weighed into the 10-gallon pail. (See figure 34.) The spring scale as used indicates the nearest one-tenth pound. Then gasoline is poured into the open-end drum, using a pail to measure, or using the stirring paddle calibrated on the basis of 1.7 gallons per inch. The thickener may be used with any automotive gasoline. However, before thickening large quantities of new lots of gasoline, it is desirable, if time permits, to prepare a small test batch of thickened fuel from each new source of gasoline. This test batch, when properly aged, may be tried in the portable flame thrower to ascertain whether the fuel fires properly. One 5-gallon batch is sufficient for this purpose. If one source of gasoline does not give satisfactory results, another source should be used. Some gasolines fail because water is present in either the gasoline or the thickener. Also, in some countries

alcohols and other combustible fluids are mixed with gasoline. Gasoline mixed with water or alcohols will not permit formation of a satisfactory gel.

b. One man stirs the gasoline vigorously with the wooden paddle while the other pours thickener into it at a uniform rate. This should be done as rapidly as possible without permitting large lumps to form. A 20-gallon batch can be mixed in 20 seconds. Large lumps of dry thickener should be broken up by hand before being added to the gasoline.

c. The fumes from the mixing drum are highly inflammable. Every precaution, therefore, must be taken to prevent ignition. Mixing should be done in the open whenever possible. No smoking or open flame of any kind should be permitted within a 50-foot radius of the mixing drum.

d. In cold weather, especially when temperatures are below 40° Fahrenheit, the mix sets much more slowly than at summer temperatures. A heated shed or building housing the apparatus will speed setting of the mix. Great care should be taken to avoid igniting the gasoline fumes, liquid mix, or gel.

42. **LOADING SHIPPING DRUM.** Stirring should be continued to keep the mix uniform until it has thickened sufficiently to prevent rapid settling of thickener particles. The mix is then bucketed immediately (figure 35) with 5-gallon pails, through the funnel into the shipping drum. Two men take care of this operation, each handling one pail so that the funnel may be kept loaded with mix and the shipping drum filled as rapidly as possible. Finally the open-end drum should be picked up and its contents poured into the funnel. Not more than 50 gallons of thickened fuel should be loaded into a 55-gallon drum. The funnel should then be removed and replaced by a plug. The vent opening, if separate, should be closed or plugged.

43. **AGING.** Thickened gasoline develops strength for sev-

eral hours after it is formed. Whenever possible, therefore, the fuel should be prepared at least 24 hours before using. It must, in addition, be allowed to "age" before being transferred to the flame thrower. During this period the small lumps, which were granulated thickener in the pre-mixed state, gradually disappear and the gel acquires uniform consistency (figure 25). The duration of the aging period as well as the stiffening time depends upon temperature, except that the aging period is a matter of hours rather than minutes. The thickened fuel should therefore be stored for aging in a warm place. A place indoors during cold weather is suitable. The thickened fuel may be stored in the shipping drums for weeks and months.



Figure 35. Transferring Newly Mixed Fuel from Mixing Drum to Shipping Drum, Where It Will "Age."

SECTION VIII

PRECAUTIONS IN HANDLING MATERIALS

	<u>Paragraph</u>
Hydrogen, nitrogen, and compressed air	44
Gasoline, thickened gasoline, and other fuels.	45

44. HYDROGEN, NITROGEN, AND COMPRESSED AIR. Personnel will familiarize themselves with the following precautions necessary in the handling of materials incident to the servicing of portable flame throwers.

a. All cylinders must be handled carefully, never dropped, and never subjected to shocks or blows. Valve caps must always be on when cylinders are being handled, unless such handling is incident to the use of the gas.

b. Cylinders may be stored in open or closed storage, but must be protected from dampness and must be protected against excessive rise in temperature from the direct rays of the sun or other source of heat. They will not be stored near highly inflammable substances, or in places where they may be struck by moving objects. Hydrogen cylinders must be kept in separate buildings or separate open storage from compressed air or other cylinders. Empty cylinders should be segregated to avoid confusion. Good ventilation should be provided to carry off leakage of hydrogen.

c. Only trained personnel will attempt to use compressed gases, and then only for the purposes for which they are intended.

d. Do not tamper with safety devices in cylinder valves. If available, use the proper replacement parts when safety devices are in need of repair. If such parts are not available, do

not attempt to use make-shifts or non-standard parts.

e. Valves must be opened slowly and fully each time hydrogen, nitrogen, or compressed air is transferred from a commercial cylinder. When a wrench is used, be sure it is one that fits properly, and that it is kept ready for instant use when a compressed gas is being released from a commercial cylinder.

f. See that threads match before making connections. Some valves are provided with special threads which must be matched by the threads in the equipment being connected.

g. Use gages, regulators, hose, pipe, and tubing of the type manufactured or specified for the particular type of apparatus or compressed gas.

h. Never attempt to alter or repair a cylinder unless such operations are covered and required by specific directions from the proper authorities.

i. Do not permit flames, sparks, or ignition from the flame thrower or other source to come in contact with the hose.

j. Immediately before coupling an attachment to the cylinder valve, open it for an instant in order to blow out any dust or dirt. Never stand where gas or dirt will be blown into the eyes or face. If the valve is difficult to open, apply more force gradually.

k. Do not attempt to use any special connections or equipment without the approval of a qualified expert.

l. Keep the valve of each cylinder closed when its contents are not being actually released from or admitted to the cylinder. This applies alike to all cylinders, whether they contain a compressed gas or are empty.

m. Hydrogen, when mixed in certain proportions with air, is explosive. Exercise particular care to prevent hydrogen leaks and to prevent its ignition in any manner except in the flame thrower burner when firing.

45. GASOLINE, THICKENED GASOLINE, AND OTHER FUELS.

a. All fuels used in flame throwers obviously are highly inflammable and must be handled, stored, and used with extreme care. Thickened gasoline gel and other fuels, such as Diesel oil and fuel oil, require the same care as does gasoline.

b. When it becomes necessary to handle gasoline in a room or building, the windows, doors, or other openings should be opened and care taken to see that no unprotected flame, which might ignite the fumes, is in the vicinity. The doors and windows should remain open for a sufficient length of time afterward to allow any vaporized gasoline to escape.

c. The presence of open flames, heated stoves, or electrical tools and apparatus, and other equipment likely to cause sparks must not be permitted. Even nails and metal cleats in shoes are a potential hazard in the presence of combustible fumes.

d. "No Smoking" signs must be posted in prominent places about the premises and the rule against smoking strictly enforced.

e. The buildings in which gasoline is stored or used must be well ventilated and thoroughly cleaned every day. No rubbish or other inflammable material must be permitted to remain in or near such buildings.

f. Care should be taken that gasoline is not spilled.

g. Safety cans should be used if possible when storing small quantities of gasoline as they have covers that must be

forcibly held open to remove or add gasoline.

h. Metal receptacles with metal lids should be provided for discarded oily or gasoline soaked rags. These rags must be disposed of daily.

i. Use vaporproof incandescent electric lamps, switches, etc., of approved type. Open switches, relays, and similar apparatus, or motors with commutators, must not be used where gasoline fumes may be encountered.

j. Flexible metal, rubber, and rubber-metal hose should be inspected regularly (at least four times a year) and discarded when noticeably deteriorated.

k. Gasoline fumes are somewhat toxic and should not be inhaled.

l. Leaks must never be neglected, and the fact that gasoline is a dangerous liquid must always be kept in mind. Inspections for leaks should be made frequently, particularly at pipe and hose joints.

m. Fire extinguishers, of carbon tetrachloride, carbon dioxide, or foam types, will be provided in a location which will be accessible in the event of fire. Sand, not water, should be thrown on the fire if suitable extinguishers are not available.

SECTION IX

CARE AND MAINTENANCE

	<u>Paragraph</u>
General	46
Cleaning	47
Inspection	48
Replacements	49
Trigger assembly	50
Adjustment of pressure regulator	51
Preparation of equipment for storage	52
Failure of burner to ignite	53
Failure of fuel discharge valve to close	54
Leak around stem of fuel discharge valve	55
Failure to obtain proper pressure	56
Leaking pressure or hydrogen cylinders	57
Leakage from hydrogen trigger valve	58

46. GENERAL. The portable flame thrower has many parts that will not stand up under abusive treatment. Reasonable care must be taken in its use. Precautions must be taken to avoid getting dirt or any foreign substance into the fuel, the pressure, and the hydrogen systems.

47. CLEANING. a. After the portable flame thrower has been used, the fuel remaining in the unit should be removed. Gasoline is a good solvent for cleaning. (See paragraph 27.)

b. Drain all fuel from the fuel hose and flush it with gasoline.

c. Remove all gummy residue from the inside surface of the gas burner with a cloth. Clean the 20 hydrogen orifices in the burner with a wire or pointed stick. (See figures 20 and 21.)

d. In severe cases clean spark plug as directed in paragraph 53 a (2).

48. INSPECTION. The following parts should be given a periodic inspection, as described:

a. All joints, especially threaded joints, should be examined for possible leaks that may be caused during use of the equipment. Paint with thick soap solution, apply pressure, and look for bubbles indicating leakage.

b. The fuel nozzle should be examined. If damaged or badly out of round, it should be replaced.

c. Other parts, such as the valves, trigger, and electrical system, should be checked to insure that they are in good working order.

49. REPLACEMENTS. a. The dry cell battery should function for the firing of about 12 loads of fuel. The battery then may be replaced.

b. The spark plug will not have to be replaced often. Generally after a spark plug is cleaned it will perform satisfactorily.

c. The pressure regulator can be removed by disconnecting it from the pressure cylinder and unscrewing it from the diffuse pipe assembly. When replacing a pressure regulator, use white lead, or litharge and glycerine, in making up the threaded pipe joints.

d. The pressure valve, hydrogen cylinder valve, and fuel discharge valve all have threaded pipe joints. When put together, white lead, or litharge and glycerine, should be used to make a pressure-tight joint (figure 36). Two end wrenches or pipe wrenches should be used (figure 37).

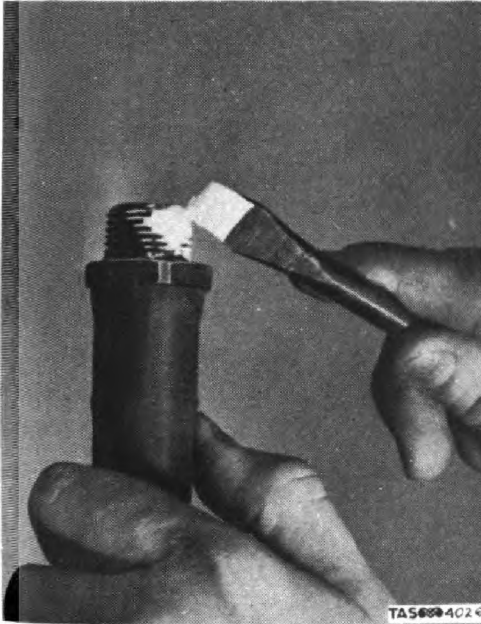

Figure 36. Applying White Lead, or Litharge and Glycerine, to Threaded Joint before Connecting.

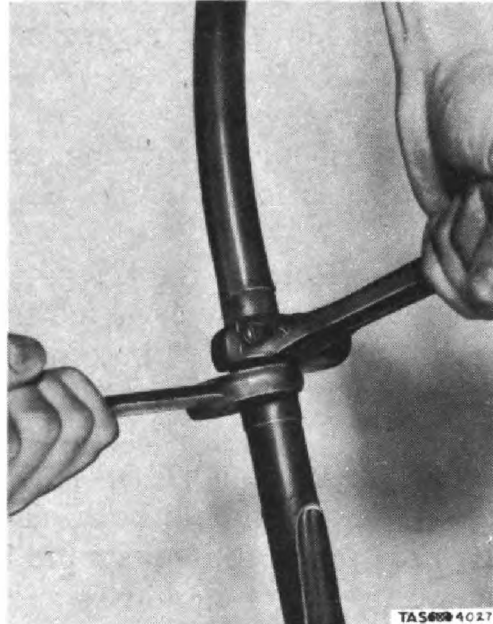

Figure 37. Use of Two End Wrenches to Tighten Joint between Fuel Hose and Fuel Discharge Valve.

e. The spark generator unit can be removed as described in paragraph 53 a (5).

50. TRIGGER ASSEMBLY. When the trigger safety key is in the operating position and depressed, the push button switch should have been depressed before the trigger valve was opened (figure 7). Proper operation can be obtained by adjusting the trigger assembly in the following manner:

a. With the trigger safety key in the safe position, release the lock screws.

b. Back off the adjusting screw over the push button switch. Then turn down until it just makes contact with the button. Lock in place by tightening the lock screw.

- c. Move the trigger safety key forward to the operating position.
- d. Depress the trigger safety key slowly until the system starts to function.
- e. Holding the trigger safety key in this position, turn the adjusting screw over the trigger valve until it just makes contact with the valve button. Then lock it in place with the lock screw.

51. ADJUSTMENT OF PRESSURE REGULATOR. The pressure regulator should be adjusted only when it is evident that the pressure is too low or too high. When it is adjusted the regulated pressure should be checked with a pressure gage. (Fig. 51, No. 17.) The pressure regulator may be adjusted as follows:

- a. Remove the fuel tank plug.
- b. Fill the fuel tanks with 5 gallons of water (or fuel).
- c. With the proper size of bushing, connect the pressure gage to the fuel tank plug hole.
- d. Connect a pressure cylinder charged to 1,800 pounds per square inch pressure. Attach it to the pressure regulator in the usual manner.
- e. Remove the two small drive screws holding the adjusting screw seal on the top of the pressure regulator, by prying (figure 38) with a strong knife blade or screwdriver.
- f. Open the pressure valve.
- g. Read the pressure and adjust the pressure regulator with the proper wrench (figure 39). To increase the pressure, turn the wrench clockwise.



Figure 38. Unprying Adjusting Screw Seal and Two Drive Screws on Pressure Regulator by Using Knife Blade.

h. To decrease the pressure, turn the wrench counter-clockwise more than is considered sufficient to effect the desired reduction. Turn the pressure cylinder valve off. Relieve pressure by compressing the fuel discharge valve until the pressure is below that desired. Then release the fuel discharge valve. Open the pressure cylinder valve and allow the system to reach a state of equilibrium, which occurs when the hissing sound ceases. Then repeat steps described above in 51 f and 51 g.

i. Press the fuel discharge valve and observe the pressure with the unit in operation.

j. After final adjustment, attach the seal (figure 40) over the adjusting screw of the pressure regulator, driving the two small drive screws into position by tapping lightly with a hammer or other tool. Replace the pressure gage with the plug in the fuel tank plug hole.



Figure 39. Adjusting Pressure Regulator, Using Hollow Set-Screw Hexagonal Wrench on the Adjusting Screw. Seal Has Been Removed.

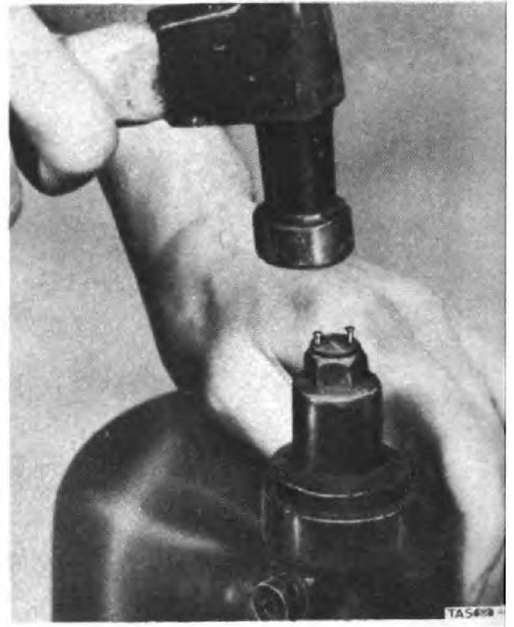

Figure 40. Replacing Adjusting Screw Seal and Two Drive Screws on Pressure Regulator by Light Hammer Taps.

52. PREPARATION OF EQUIPMENT FOR STORAGE. Equipment is prepared for storage in the following manner:

- a. Disconnect the gun from the fuel unit.
- b. Release the pressure from the fuel tanks by slowly unscrewing the fuel tank plug.
- c. Remove the fuel from the fuel tanks through the plug hole and open the fuel valve to vent the tanks.
- d. Disconnect the pressure cylinder and release the pressure.

e. Release the pressure from the hydrogen cylinder.

CAUTION: THIS OPERATION SHOULD BE DONE OUT OF DOORS. NO SMOKING.

f. Remove the battery.

g. Clean the unit as directed in paragraph 47.

53. FAILURE OF BURNER TO IGNITE. Reasons for the failure of the burner to ignite fall under two general headings:

a. Failure of the electrical system. Before testing the electrical system, assurance should be had that the hydrogen cylinder valve is tightly closed. Then open the trigger valve once or twice to empty the line of hydrogen. Press the push button switch. If the buzz of the interrupter is heard, look into the open end of the gun (if possible in a fairly dark place), and

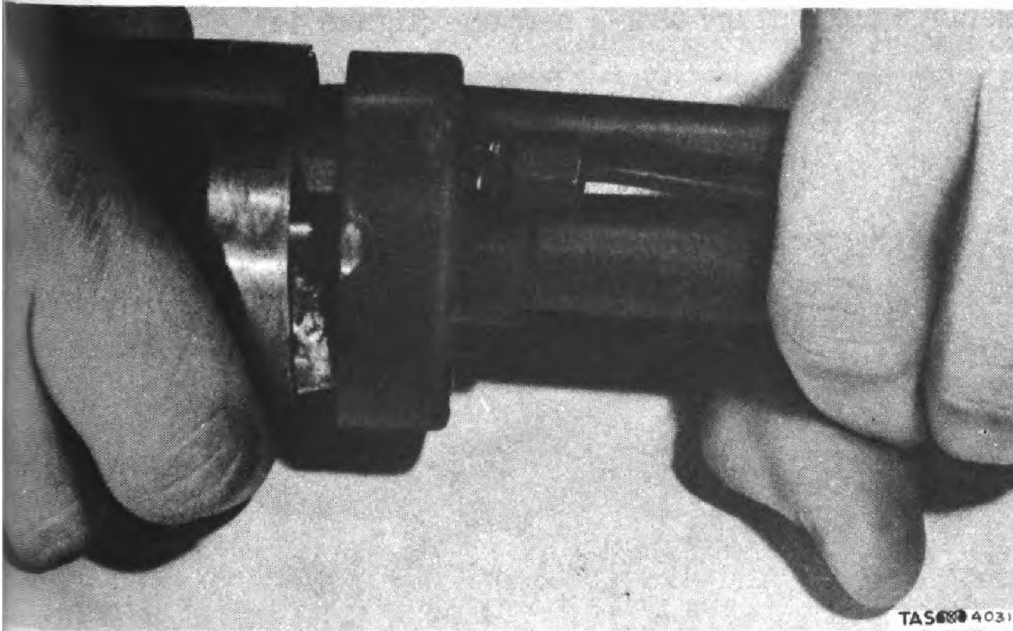

Figure 41.. Burner Guard Twisted by Hand from Guard Cap and over Outer Sleeve.

see if a spark is visible.

(1) If there is no spark, remove the burner guard (figure 41) as described in paragraph 5 h. Remove lead wire from the spark plug, bring the metal terminal clip close to some clean metal surface on the gun (figure 42), and depress the switch.

(2) If a spark is obtained, the defect is in the spark plug. Remove the plug, clean it of any foreign matter, wash it in gasoline, check the gap between electrodes, which should be approximately .010-inch, and replace (figure 43).

(3) If the "buzz" of the interrupter can be heard, but no spark obtained from the terminal clip, there is probably a short circuit through the insulation of the ignition cable.

(4) If no "buzz" is heard when the switch is pressed, replace the battery with a new one (figure 44).



Figure 42. Touching Spark Plug Lead Wire Clip to Gun to Test for Spark.

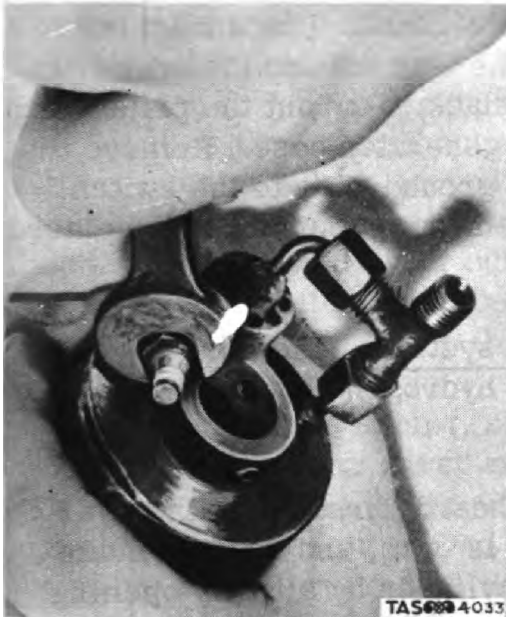

Figure 43. Tightening Spark Plug after Cleaning or Replacing.



Figure 44. Battery Removed from Spark Generator Housing with Plug Pulled from Battery. Housing Cap Is in Foreground.

(5) If there is still no "buzz," there is probably a defect in the spark coil or interrupter. In this case, or in the event of a breakdown of its insulation, replace the spark generator. To do this, remove the lead wire from the spark plug. Remove the cap from the spark generator housing. Remove the battery. Slide the conduit up into the burner as far as it will go. Pull out the spark generator case by pulling on the ignition cable. Remove the two plugs from the jacks at the ends of the spark generator case, and remove the spark generator by pulling the ignition cable through the conduit. Insert a new spark generator by threading the ignition cable through the conduit and retracing the above steps. An earlier type of electrical system requires the following procedure for replacing the spark generator: Remove the hydrogen cylinder. Remove the screws which hold

the spark generator housing to the fuel tube. Disconnect the lead from the spark plug and pull the lead toward the spark generator housing to give 6 inches of slack. Pry out the plate which is found at the bottom of the spark generator case. Remove the lock nut push button switch and the ground wire to the switch. The spark generator can then be removed. Usually the replaced spark generator can be salvaged.

b. Failure of the hydrogen system. When the trigger valve is pressed, the escape of the hydrogen should cause a hissing sound.

(1) If this "hiss" is not heard, first check the hydrogen cylinder valve to insure that it is open, and second, make sure that there is hydrogen in the cylinder by slightly opening the cylinder connection.

(2) If hydrogen issues through the holes in the burner and if the spark plug is working, the hydrogen nozzle or burner head may be blocked. To get at this nozzle, or head, remove the burner guard. Disconnect the hydrogen line at the burner. Disconnect the ignition cable at the spark plug, and remove the burner (if it is not brazed to the nozzle) by loosening the set screws holding it to the fuel nozzle. Disconnect the hydrogen line at the hydrogen nozzle, or burner head. Any foreign substance may be blown out. Do not enlarge the hole in this tube. If the burner is brazed on the fuel nozzle, a wire or pointed stick may be inserted into the burner head to clean it out. The burner assembly may also be dipped in gasoline. Foreign substances may be blown out by compressed gases.

54. FAILURE OF FUEL DISCHARGE VALVE TO CLOSE.

a. This causes leakage from the fuel nozzle. The instructions in b and c apply to the Y-valve. The Beattie valve should be replaced if it fails to close. (Fig. 4)

b. The packing nut on the valve stem may be too tight.

Loosen the packing nut, but not enough to cause it to leak around the valve stem.

c. If the packing nut cannot be loosened sufficiently without causing a leak around the stem, proceed as follows: Close the fuel valve. Remove the operating lever of the fuel discharge valve by driving out the pivot pin. Remove the nut on the valve stem, after first loosening the lock screw in the nut. Unscrew the hexagonal cap through which the valve stem passes. This will enable the valve stem spring and valve plug to be withdrawn. Remove the spring, stretch it to increase its tension, and replace the parts, first examining the valve plug and the valve seat to see if they require regrinding. If the valve seat and plug are pitted or scored so as to prevent proper seating, the valve may be reground. If regrinding facilities are not available, the valve may be replaced.

55. LEAK AROUND STEM OF FUEL DISCHARGE VALVE. Tighten the packing nut on the valve stem. If this causes the valve stem to bind, proceed as in paragraph 54.

56. FAILURE TO OBTAIN PROPER PRESSURE. If, in firing the flame thrower, the proper range is not obtained, check the unit as follows:

a. Determine whether the pressure cylinder valve and the fuel valve are fully open.

b. Replace the pressure cylinder with another cylinder that is known to be fully charged.

c. When fuel has been released through the fuel discharge valve, the compressed air or nitrogen should be heard, for a short time, flowing into the fuel tanks to replace the volume of fuel used. If the air or nitrogen fails to replace the fuel used, the pressure regulator is at fault. It may either "stick" or be out of adjustment. To adjust the pressure regu-

lator, see paragraph 51.

57. LEAKING PRESSURE OR HYDROGEN CYLINDERS. a. To test for leaks, change the cylinders. Immerse in water or paint with a thick soap solution. Look for bubbles, which indicate a leak.

b. To repair a leak at the joint between the cylinder and valve, first release all pressure. Then unscrew the valve from the cylinder. Clean the threads, removing all old joint compound with a knife or stiff brush, taking care not to permit particles to fall into the cylinder or valve. Put new compound on the threads, as shown in figure 36. Screw valve on tightly and retest, as in a, above.

c. Leaks in the valve proper can usually be corrected by tightening the packing nut.

58. LEAKAGE FROM HYDROGEN TRIGGER VALVE. If the trigger valve leaks, it should be discarded and replaced.

SECTION X

EQUIPMENT AND MATERIAL

	<u>Paragraph</u>
General	59
M1 service kit	60
M1A1 service kit	61
Fuel filling kit	62
Fuel mixing kit	63
Locally obtained equipment	64

59. GENERAL. The portable flame thrower is serviced in the field by a service kit, a fuel filling kit, and a fuel mixing kit. In addition, a few items incident to mixing operations must be obtained locally. Because of its prior design and issue, the M1 flame thrower is serviced by a service kit differing somewhat in its component parts from that issued with M1A1 flame throwers. These differences are set forth in subsequent paragraphs and illustrations.

60. M1 SERVICE KIT. The tools, replacement parts, materials, and accessories packed in the M1 service kit comprise the following in respective quantities (see figures 45, 46, 47, and 48):

- 1 - Chest, packing. (Figs. 45 and 46)
- 1 - Hydrogen cylinder filling manifold assembly. (Fig. 46)
- 1 - Pressure (or nitrogen) cylinder filling manifold assembly. (Fig. 46)
- 2 - Fuel hose assemblies. (Fig. 47, No. 1)
- 6 - Cable, ignition, insulated, 16-gage, 22 inches long. (Fig. 47, No. 2)
- 1 - Blow torch, gasoline, with soldering point. (Fig. 47, Nos. 3, 8)

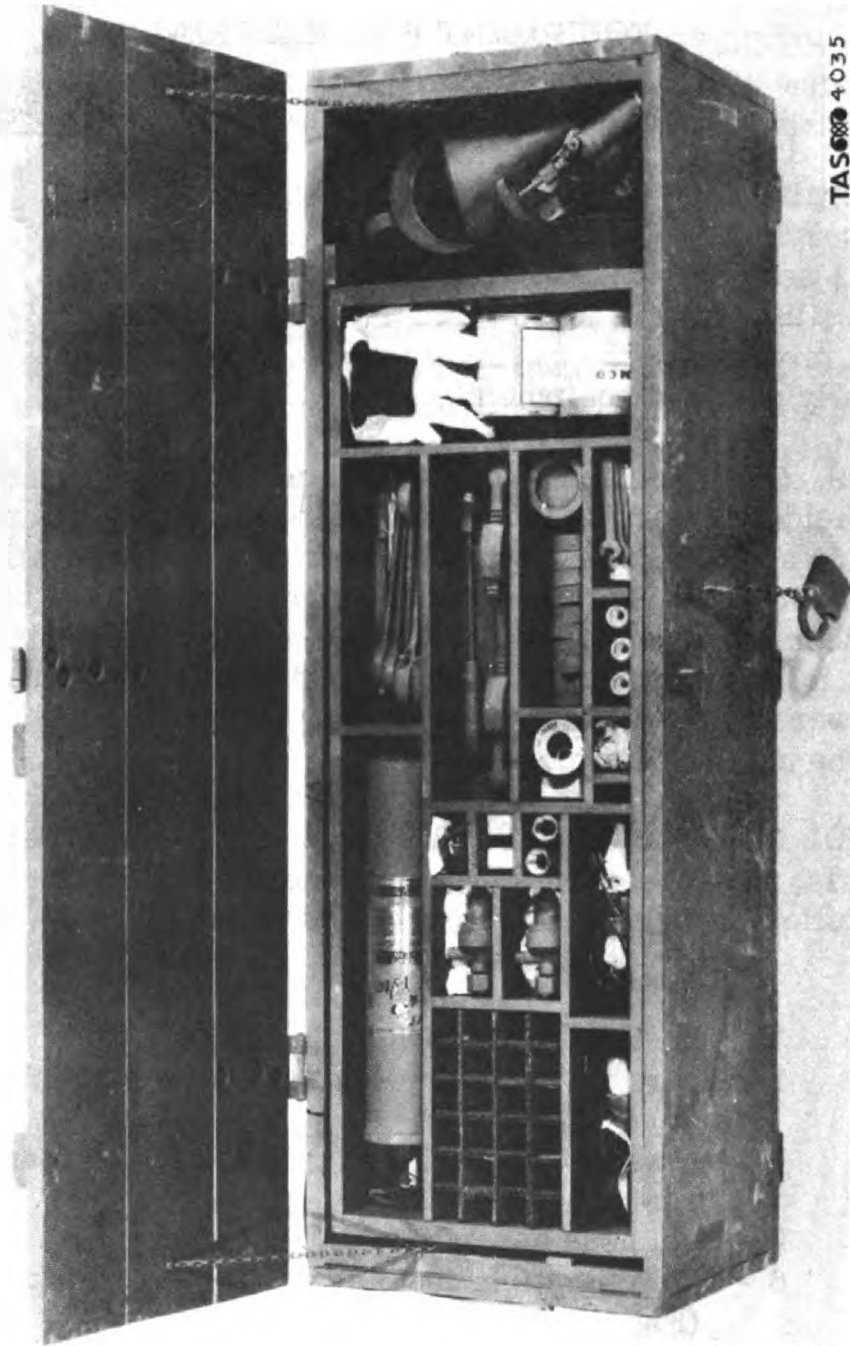
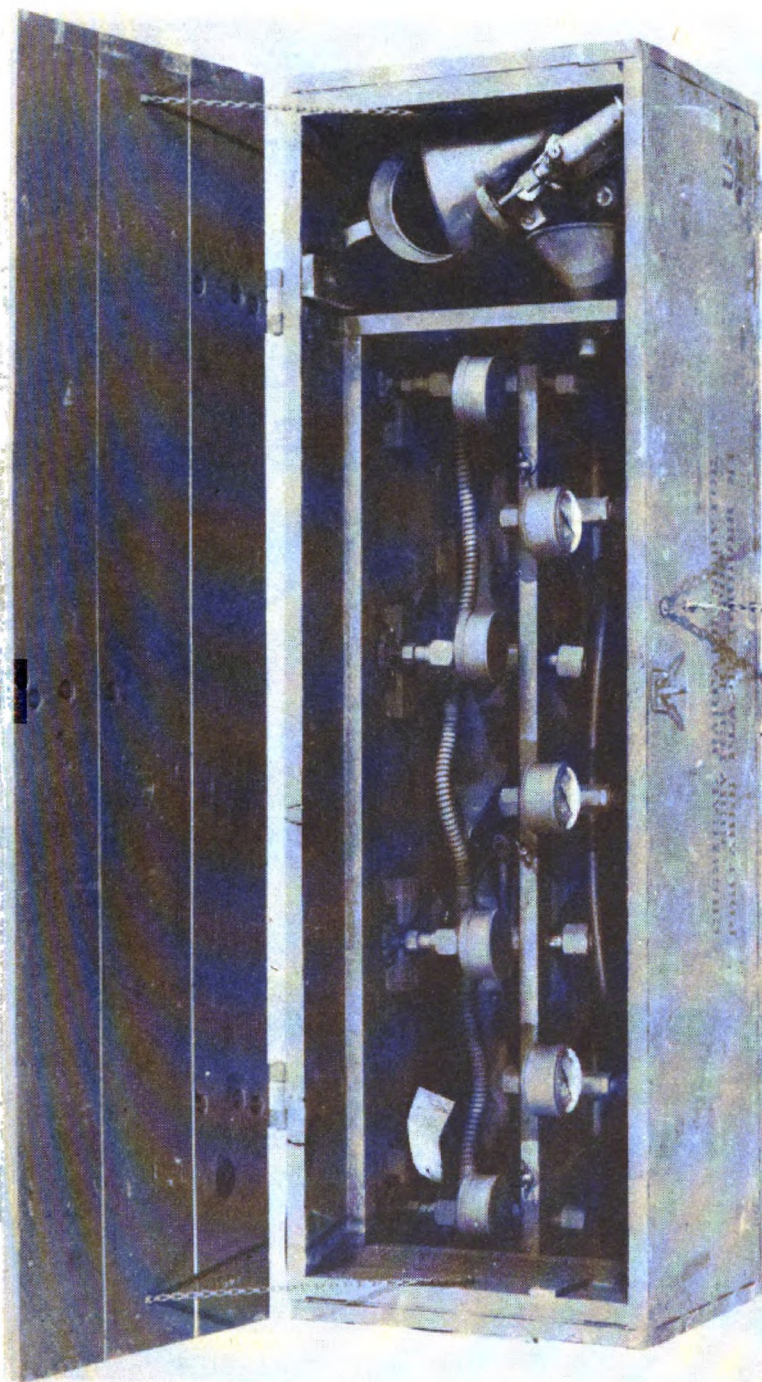

Figure 45. Kit, Service, M1, Showing Contents of Lift-Out Tray. (See Paragraph 60.)



TAS 4-036

Figure 46. Kit, Service, M1, Showing Filling Manifold Assemblies for Hydrogen and Pressure Cylinders. (See Paragraph 60.)

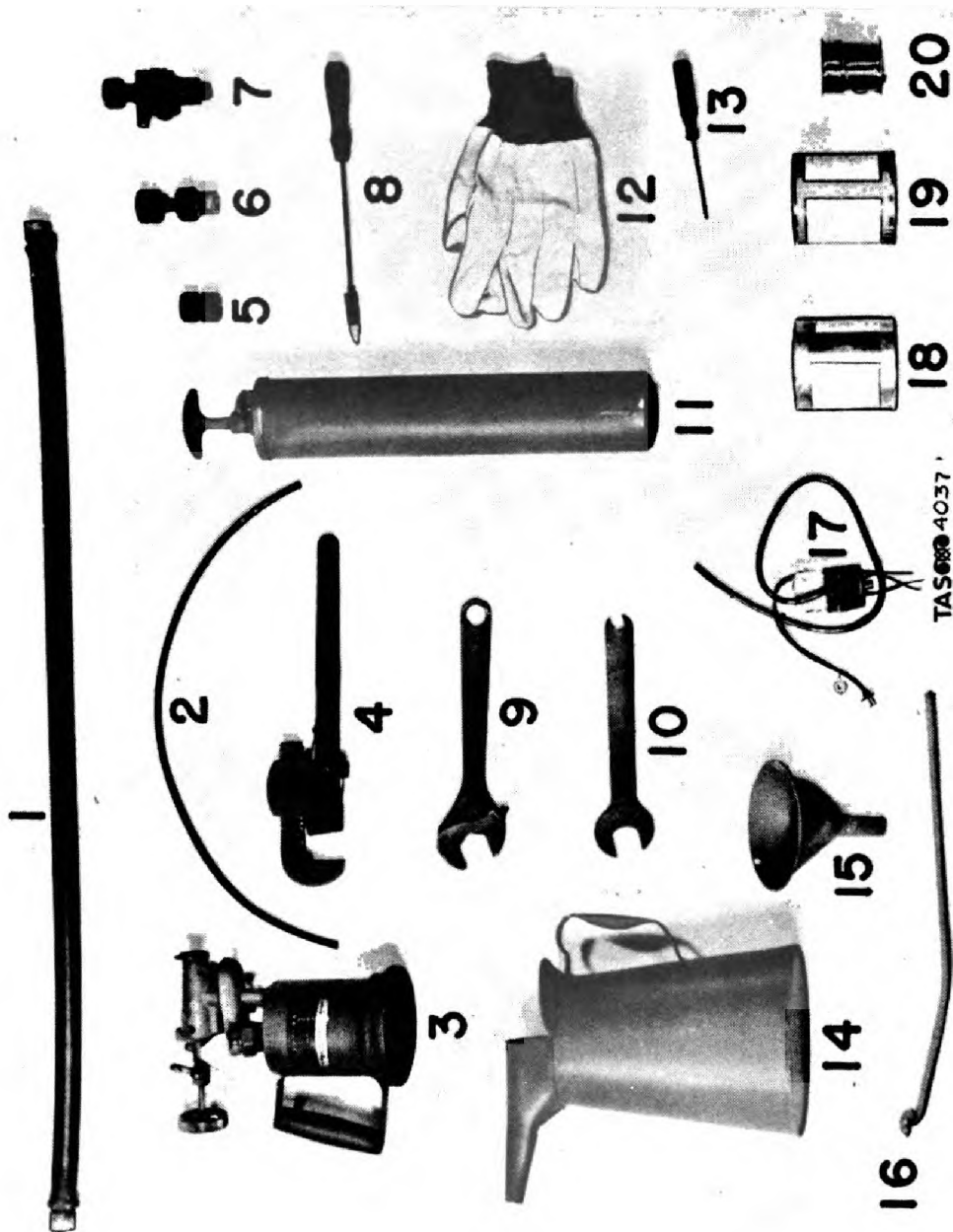
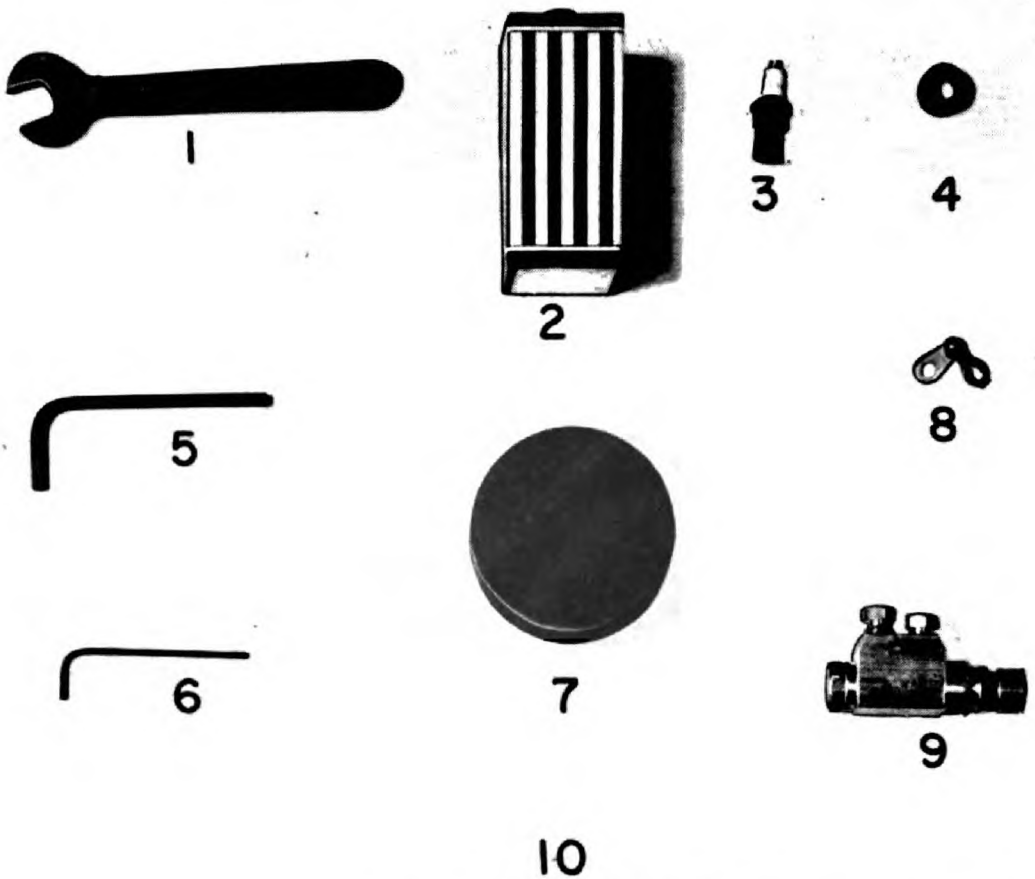

Figure 47. Partial Contents of M1 Service Kit. (See Paragraph 60.)



TAS 4038

Figure 48. Partial Contents of M1 Service Kit. (See Paragraph 60.)

- 2 - Wrenches, pipe, 14-inch. (Fig. 47, No. 4)
- 2 - Unions, adapter, 1/2-inch. (Fig. 47, No. 5)
- 3 - Adapters, for hydrogen cylinders. (Fig. 47, No. 6)
- 2 - Pressure regulator assemblies. (Fig. 47, No. 7)
- 2 - Wrenches, adjustable, 10-inch. (Fig. 47, No. 9)
- 5 - Wrenches, special. (Fig. 47, No. 10)
- 1 - Fire extinguisher, 1-1/2-qt., with wall bracket.
(Fig. 47, No. 11)
- 5 - Pairs, gloves, canvas. (Fig. 47, No. 12)
- 1 - Screwdriver, common, 3/16-inch blade. (Fig. 47,
No. 13)
- 1 - Measure, utility, funneled, 4-qt. (Fig. 47, No. 14)
- 2 - Funnel assemblies. (Fig. 47, No. 15)
- 6 - Electrical conduit assemblies. (Fig. 47, No. 16)
- 2 - Spark generator assemblies. (Fig. 47, No. 17)
- 1 - Glycerin, 1-qt. can (Fig. 47, No. 18)
- 1 - Lead oxide (litharge), 1-lb. (Fig. 47, No. 19)
- 1 - Solder, resin core, 1-lb. spool. (Fig. 47, No. 20)
- 1 - Wrench, engineers, 3/8-inch, 15 degree angle. (Fig.
48, No. 1)
- 24 - Batteries, 3-volt, less adapter plug, 1-3/16 x 1-3/16
x 2-19/32 inches. (Fig. 48, No. 2)
- 6 - Spark plugs. (Fig. 48, No. 3)
- 1 - Box, valve seats. (Fig. 48, No. 4)
- 1 - Wrench, hexagonal, for hollow set-screw, 1/4-inch.
(Fig. 48, No. 5)
- 1 - Wrench, hexagonal, for hollow set-screw. (Fig. 48,
No. 6)
- 5 - Caps, front, housing. (Fig. 48, No. 7)
- 1 - Box, spark plug terminal clips. (Fig. 48, No. 8)
- 2 - Trigger valve assemblies. (Fig. 48, No. 9)
- 24 - Wires, iron, .032-inch diameter, 8 inches long. (Fig.
48, No. 10)

61. M1A1 SERVICE KIT. The tools, replacement parts, materials, and accessories packed in the M1A1 service kit comprise the following in respective quantities (see figures 49, 50,

51, and 52):

- 1 - Chest, packing. (Figs. 49, 50)
- 1 - Hydrogen cylinder filling manifold assembly. (Fig. 50)
- 1 - Pressure (or nitrogen) cylinder filling manifold assembly. (Fig. 50)
- 5 - Wrenches, construction, 1-inch opening, 14-1/2 inches long. (Fig. 51, No. 1)
- 2 - Wrenches, pipe, 14-inch. (Fig. 51, No. 2)
- 2 - Wrenches, adjustable, 10-inch. (Fig. 51, No. 3)
- 1 - Lead oxide (litharge), 1-lb. container. (Fig. 51, No. 4)
- 1 - Solder, resin core, 1-lb. spool. (Fig. 51, No. 5)
- 2 - Fuel hose assemblies. (Fig. 51, No. 6)
- 1 - Blow torch, gasoline, with 3/8-inch soldering point. (Fig. 51, No. 7)
- 1 - Screwdriver, common, 3/16-inch blade. (Fig. 51, No. 8)
- 6 - Cables, ignition, insulated, 16-gage, 22 inches long. (Fig. 51, No. 9)
- 6 - Conduits, electrical, seamless brass tubing. (Fig. 51, No. 10)
- 1 - Measure, utility, funneled, 4-qt. (Fig. 51, No. 11)
- 2 - Unions, adapter, 1/2-inch. (Fig. 51, No. 12)
- 5 - Pairs, gloves, canvas. (Fig. 51, No. 13)
- 3 - Adapters for hydrogen cylinders. (Fig. 51, No. 14)
- 2 - Pressure regulator assemblies. (Fig. 51, No. 15)
- 2 - Spark generator assemblies. (Fig. 51, No. 16)
- 1 - Testing gage assembly. (Fig. 51, No. 17)
- 1 - Glycerin, 1-qt. can. (Fig. 51, No. 18)
- 1 - Fire extinguisher, 1-1/2-qt., with wall bracket. (Fig. 51, No. 19)
- 1 - Box, spark plug terminal clips. (Fig. 52, No. 1)
- 5 - Caps, front, housing. (Fig. 52, No. 2)
- 3 - Wrenches, hexagonal, for No. 6 hollow set-screw. (Fig. 52, No. 3)

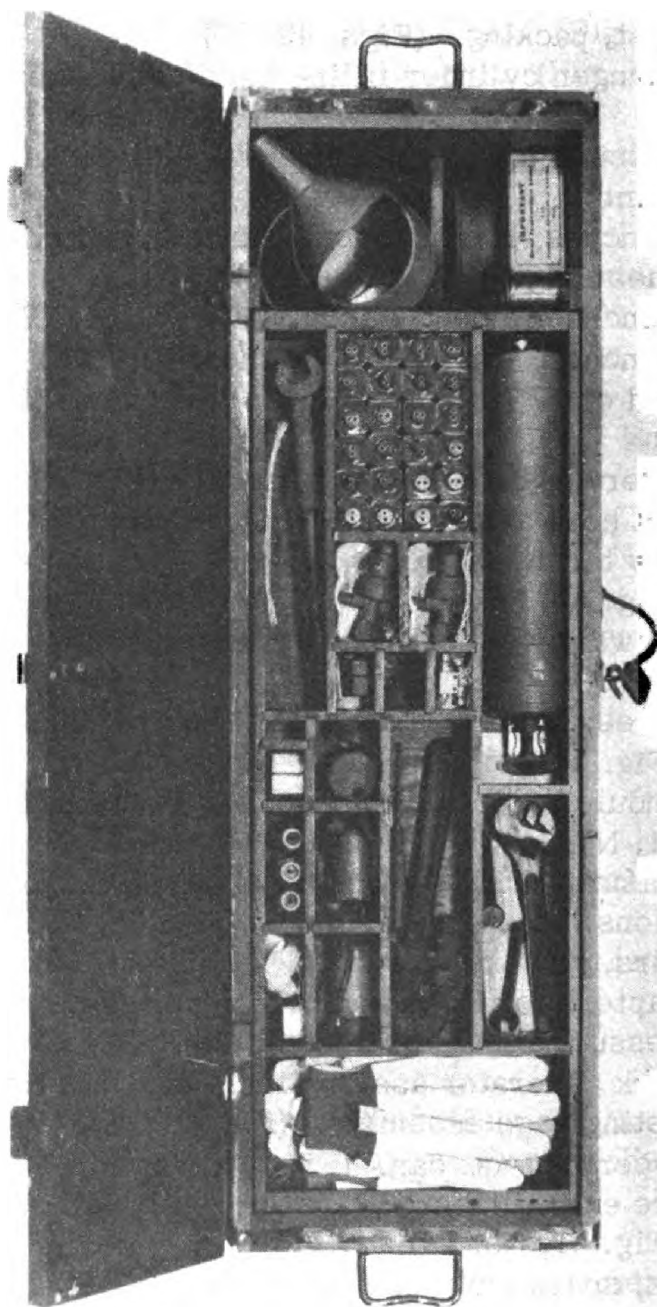

TAS 4039

Figure 49. M1A1 Service Kit, Showing Contents of Tray. (See Paragraph 61)

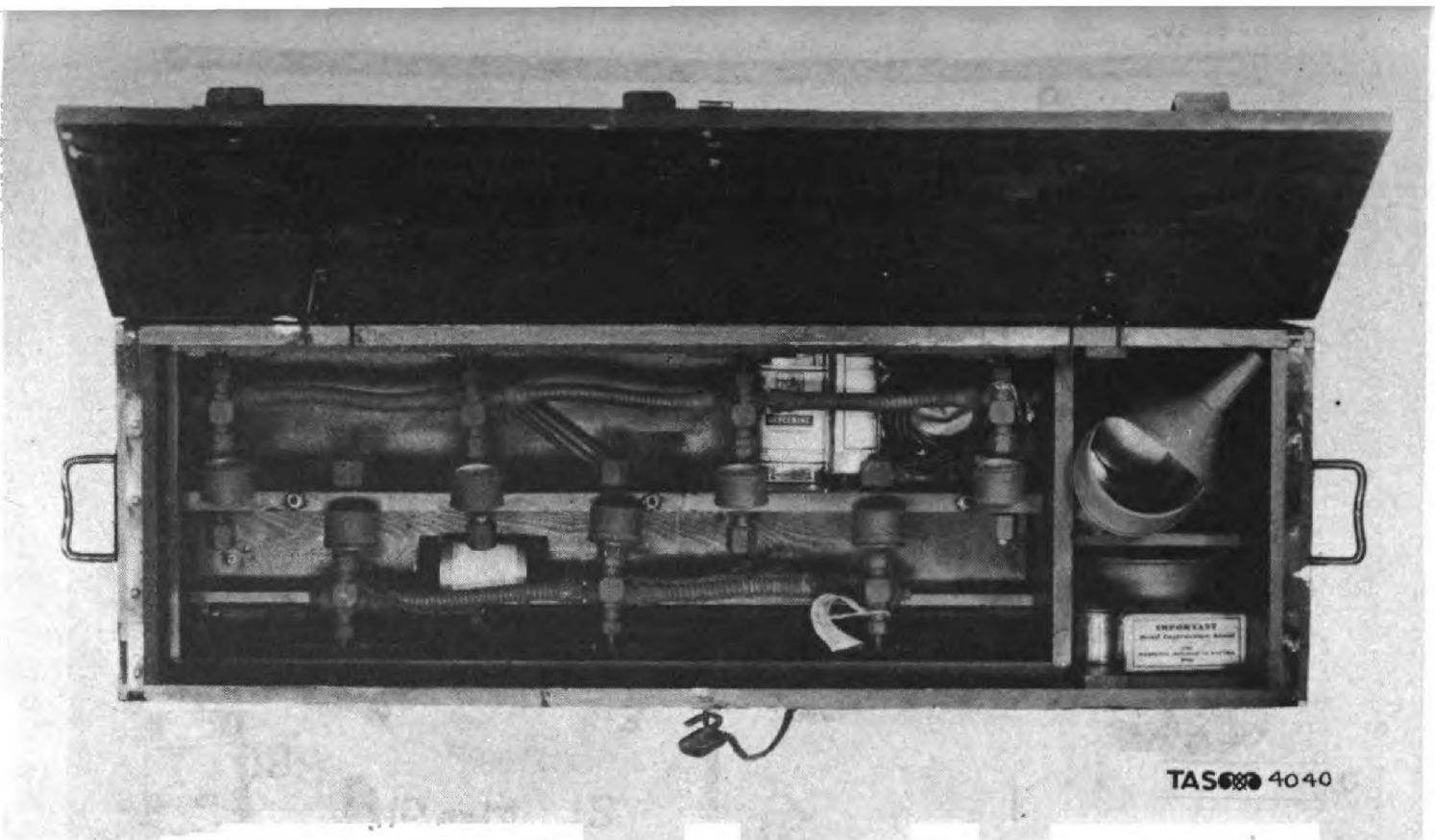
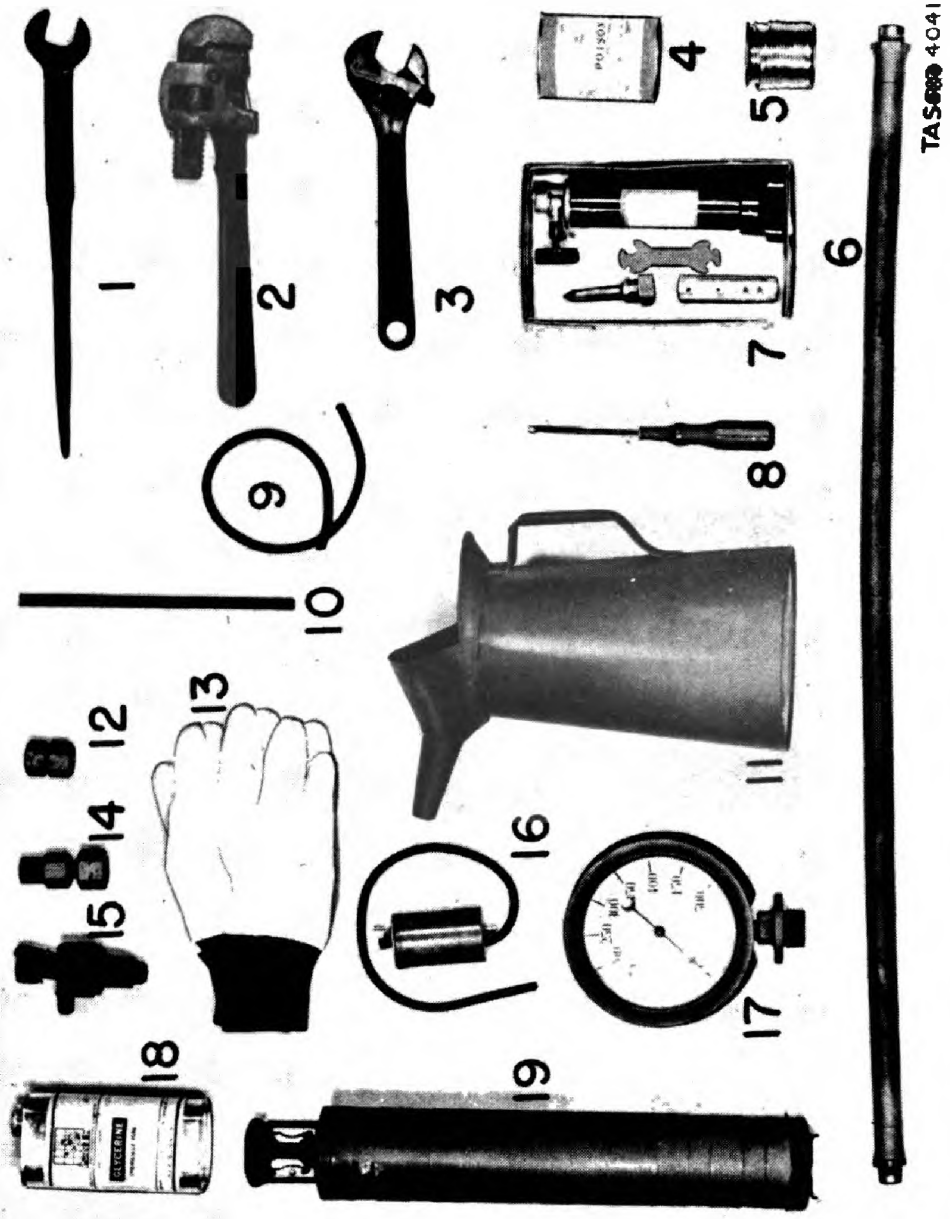

Figure 50. M1A1 Service Kit, with Tray Removed, Showing Filling Manifold Assemblies for Hydrogen and Pressure Cylinders. (See Paragraph 61.)



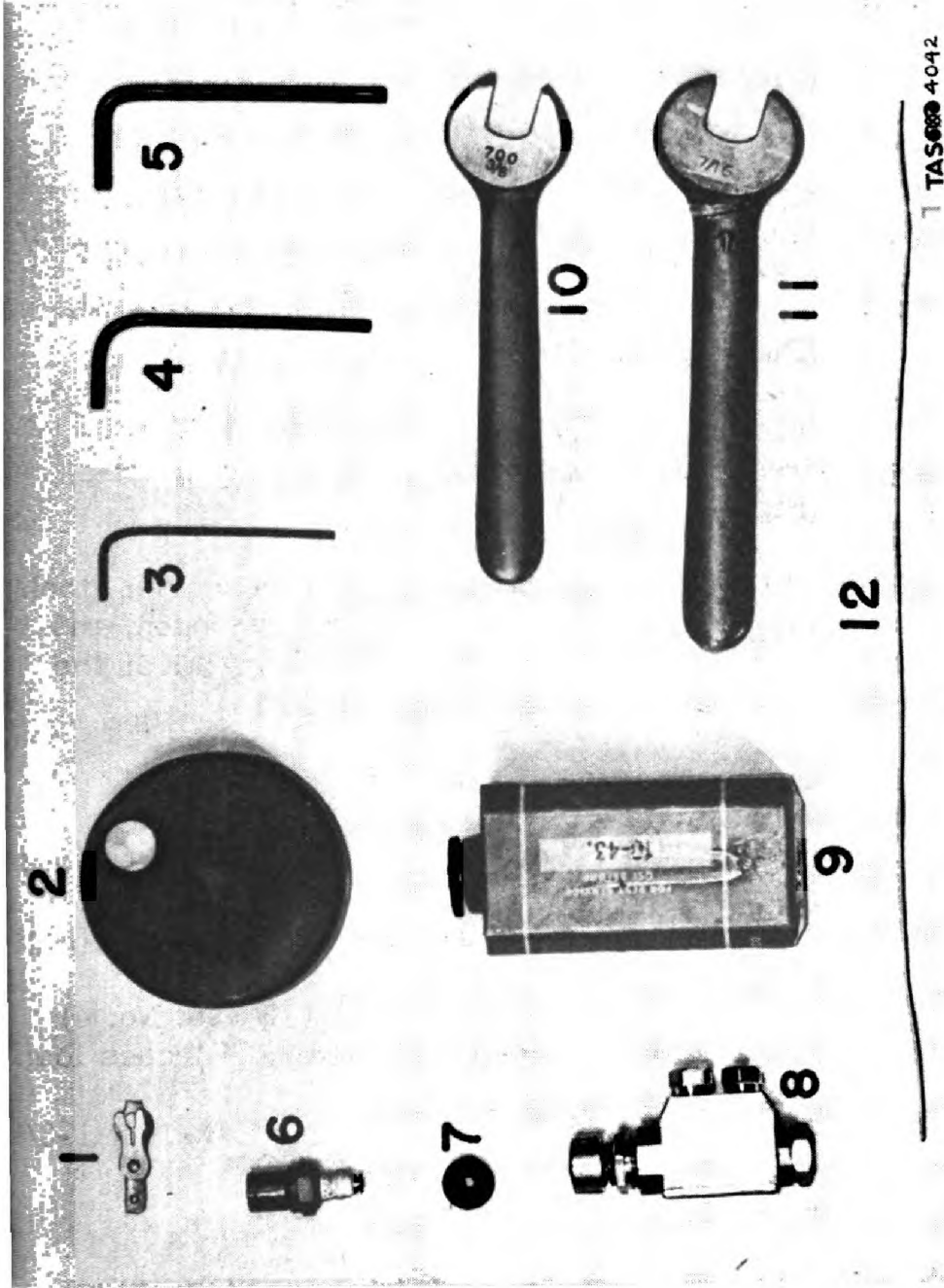

Figure 52. Partial Contents of M1A1 Service Kit. (See Paragraph 61.)

- 3 - Wrenches, hexagonal for 1/4-inch hollow set-screw (Fig. 52, No. 4)
- 3 - Wrenches, hexagonal, for 5/16-inch hollow set-screw (Fig. 52, No. 5)
- 6 - Spark plugs. (Fig. 52, No. 6)
- 1 - Box, valve seats. (Fig. 52, No. 7)
- 2 - Trigger valve assemblies. (Fig. 52, No. 8)
- 24 - Batteries, 3-volt, less adapter plug, 1-3/16 x 1-3/16 x 2-19/32 inches. (Fig. 52, No. 9)
- 3 - Wrenches, engineers, 3/8-inch, 15 degree angle. (Fig. 52, No. 10)
- 3 - Wrenches, engineers, 7/16-inch, 15 degree angle. (Fig. 52, No. 11)
- 24 - Wires, iron, .032-inch diameter, 8 inches long. (Fig. 52, No. 12)

62. FUEL FILLING KIT. The following accessories, tools, and replacement parts for the fuel, pressure, hydrogen, and electrical systems are contained in the fuel filling kit in the respective quantities (see figures 53, 54, and 55):

- 1 - Packing chest. (Figs. 53, 54)
- 1 - Fuel hose (oil hose). (Fig. 55, No. 1)
- 1 - Pipe, suction, 1-1/4-inch diameter, 35 inches long. (Fig. 55, No. 2)
- 15 - Pressure (or nitrogen) cylinders and valves. (Fig. 55, No. 3)
- 15 - Hydrogen cylinders and valves. (Fig. 55, No. 4)
- 1 - Pipe, suction, 1-1/4-inch diameter, 24 inches long. (Fig. 55, No. 5)
- 6 - Batteries, 3-volt, less adapter plug, 1-3/16 x 1-3/16 x 2-19/32 inches. (Fig. 55, No. 6)
- 6 - Spark plugs. (Fig. 55, No. 7)
- 1 - Pump, force, hand. (Fig. 55, No. 8)
- 2 - Wrenches, construction, 1-inch, 14-1/2 inches long. (Fig. 55, No. 9)
- 2 - Wrenches, adjustable, 10-inch. (Fig. 55, No. 10)

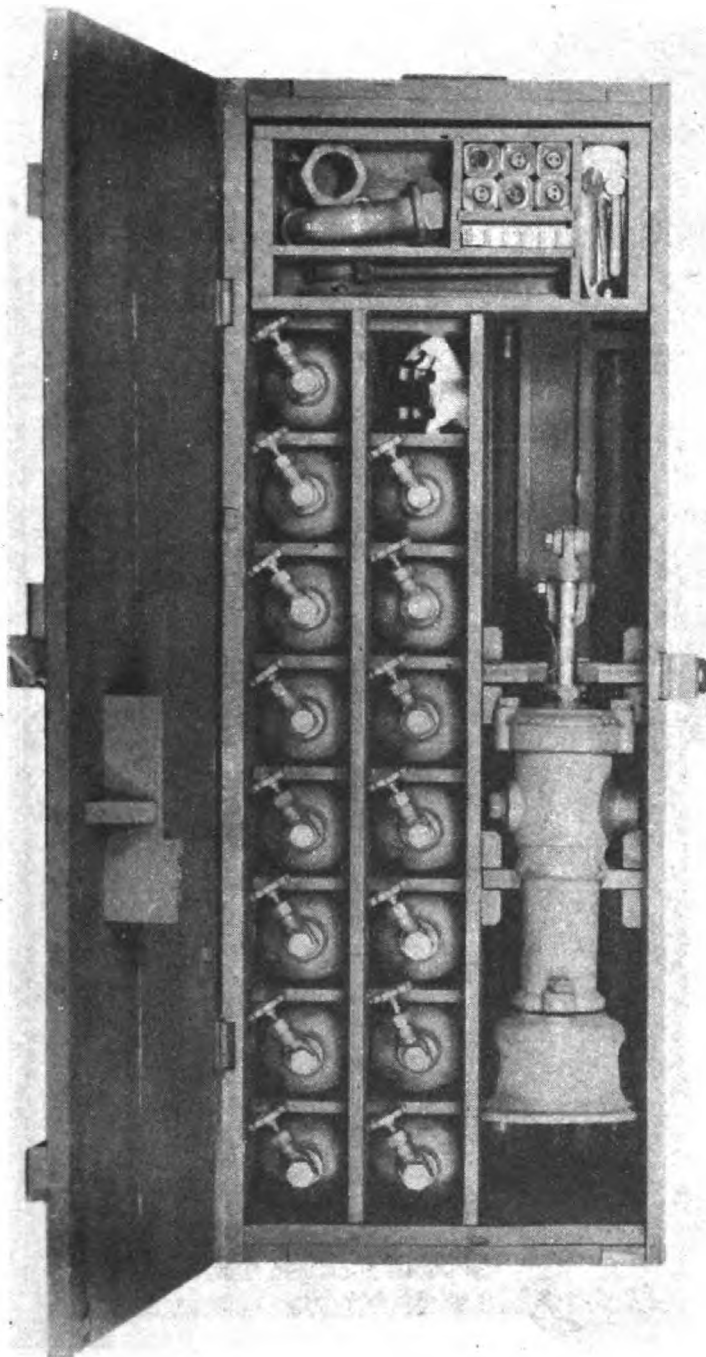
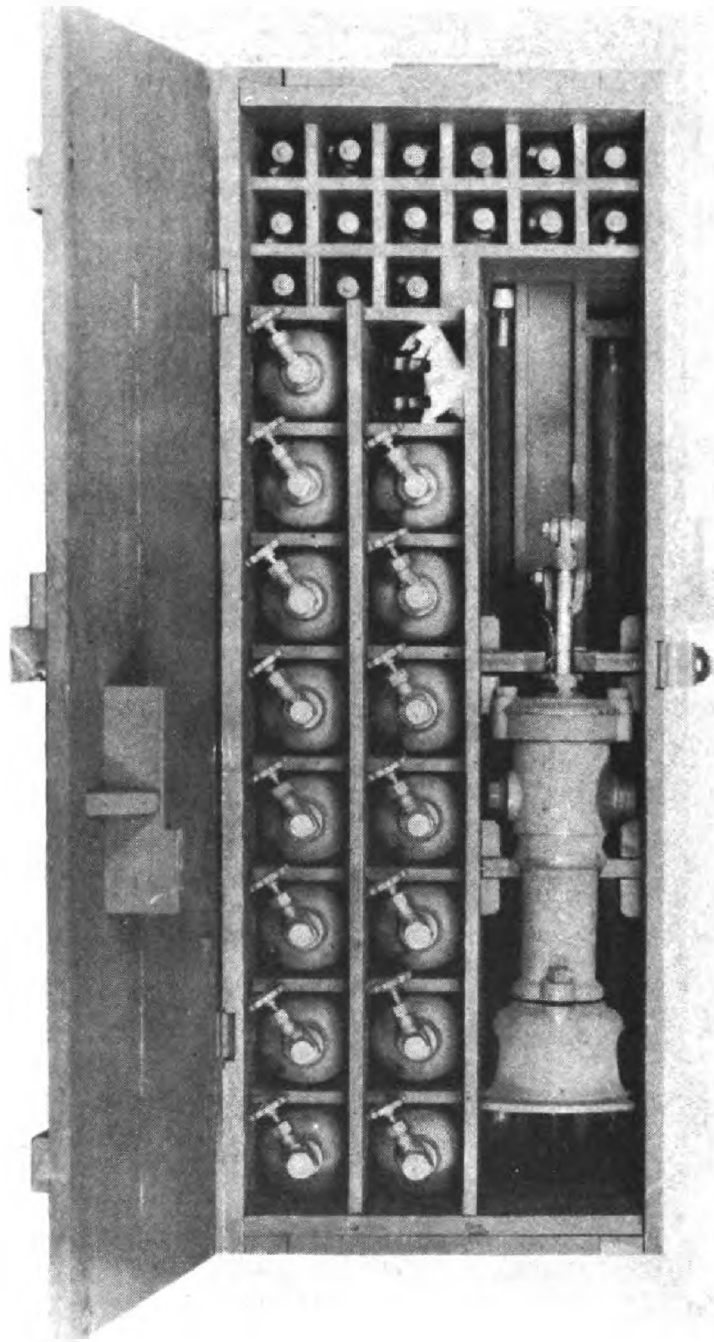

Figure 53. Fuel Filling Kit, Showing Tray. (See Paragraph 62.)



TAS 680 4044

Figure 54. Fuel Filling Kit, with Tray Removed. (See Paragraph 62.)

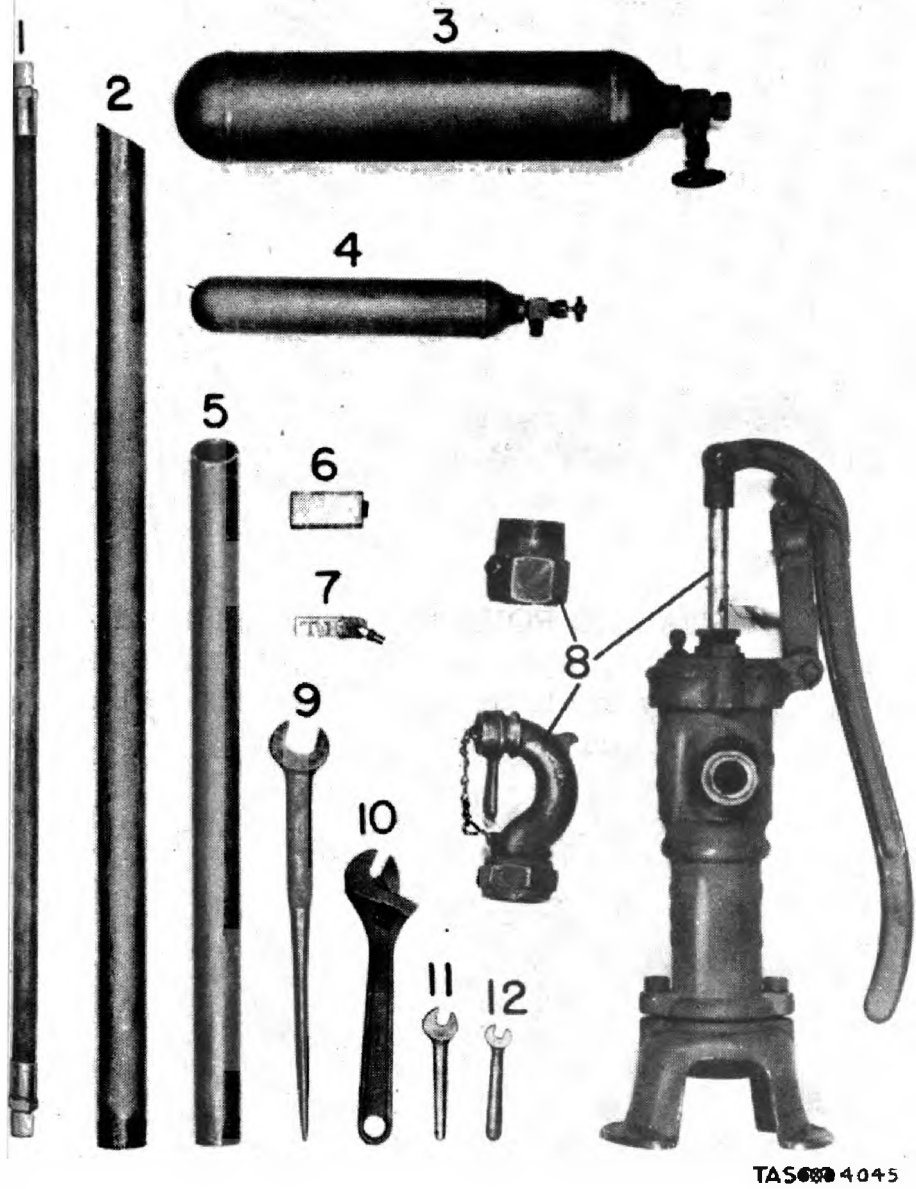

Figure 55. Partial Contents of Fuel Filling Kit.
(See Paragraph 62.)

- 2 - Wrenches, engineers, 7/16-inch, 15 degree angle.
(Fig. 55, No. 11)
- 2 - Wrenches, engineers, 3/8-inch, 15 degree angle.
(Fig. 55, No. 12)

63. FUEL MIXING KIT. This kit contains the following equipment in the respective quantities for preparing thickened gasoline (see figures 56 and 57):

- 1 - Chest, packing.
- 2 - Pails, 5-gallon.
- 1 - Pail, 10-gallon.
- 1 - Scale, 30 pounds capacity, measured in 1/10 pounds.
- 1 - Funnel vent. (Seamless copper tubing.)
- 1 - Funnel.
- 2 - Funnel adapters.

64. LOCALLY OBTAINED EQUIPMENT. The following containers and paddle, used in preparing thickened gasoline, are not supplied in kits. They are to be procured or improvised from locally available materials (see figure 32):

- 1 - Drum, open-end, not galvanized, 55-gallon.
- 2 - Drums, closed-end, not galvanized, 55-gallon.
- 1 - Mixing paddle and measuring stick.

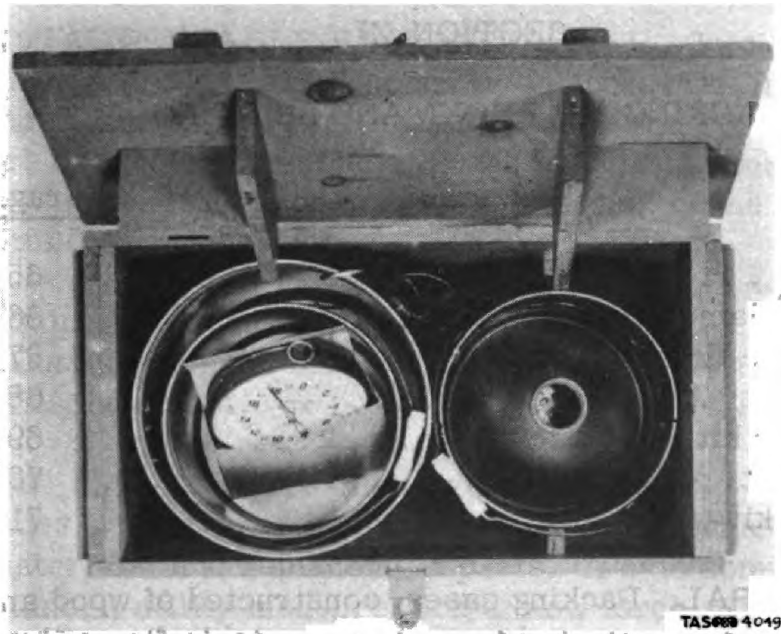

Figure 56. Fuel Mixing Kit.

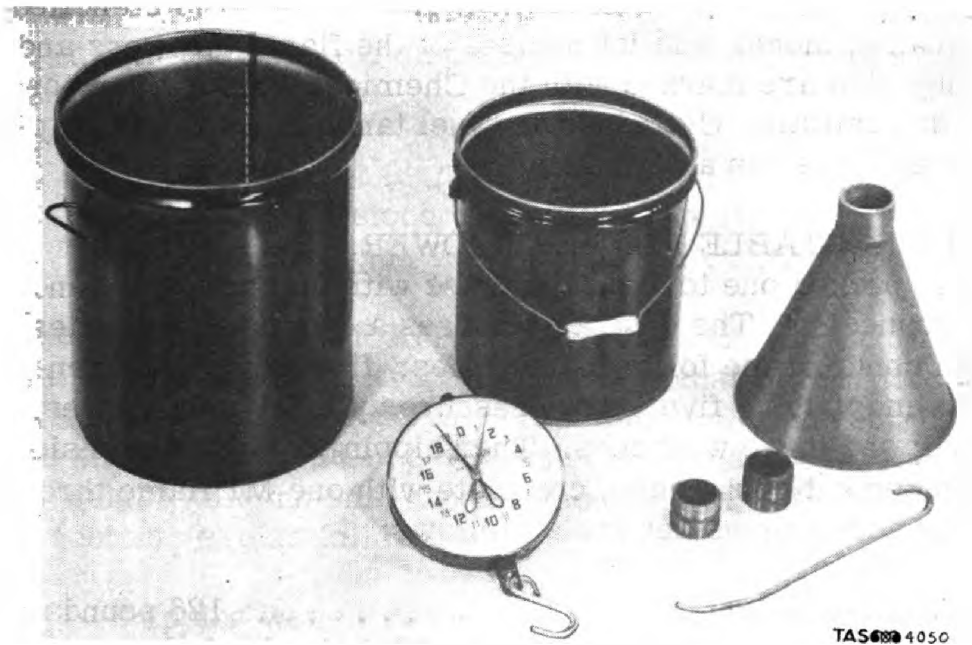

Figure 57. Partial Contents of Fuel Mixing Kit.

SECTION XI

PACKING, MARKING, AND SHIPPING

	<u>Paragraph</u>
General	65
M1 portable flame thrower.	66
M1A1 portable flame thrower.	67
M1 service kit.	68
M1A1 service kit	69
Fuel filling kit.	70
Fuel mixing kit	71

65. GENERAL. Packing cases, constructed of wood and painted olive drab, are used to ship the portable flame throwers and the parts and materials found in the service, filling, and mixing kits. The various cases have steel strap-hinged wooden covers, with hinge hasps to keep them closed. Each is stenciled with the name, model, and lot number of the flame throwers and kits. They also are marked with the Chemical Warfare Service insignia and initials. Cylinders and fuel tanks are shipped empty unless early use is anticipated.

66. M1 PORTABLE FLAME THROWER. The M1 flame thrower is packed one to a packing case with fuel unit, gun, and hose disconnected. The case also houses a canvas accessories set which contains the following supplies: five extra hydrogen cylinders and valves; five extra pressure cylinders and valves; one funnel; and three wrenches. The shipping weight, dimensions, and displacement of the case, complete with one M1 flame thrower and one accessories set, are as follows:

Shipping weight 126 pounds
 Outside dimensions 48 x 16-1/4 x 15-1/2 inches
 Displacement 7.0 cubic feet

67. M1A1 PORTABLE FLAME THROWER. Two portable flame throwers, M1A1, are packed in one box. The fuel units are shipped disconnected from the fuel hose and guns, which latter are held in compartments in the base of the box. The shipping weight, dimensions, and displacement of the packed box are as follows:

Shipping weight 130 pounds
Outside dimensions 47-1/4 x 17-3/4 x 16 inches
Displacement 7.7 cubic feet

68. M1 SERVICE KIT. (See figures 45, 46, 47, 48.) This kit includes a plywood and wood partitioned tray which holds tools, materials, and replacement parts. A side compartment holds a funnel, utility measure, and a blow torch. The space beneath the tray holds the pressure and hydrogen cylinder filling manifolds in place rigidly by means of wood spacers, cradles, and clamping strips, and by steel hanger bolts, washers, and wing nuts. A padlock and chain are provided. The shipping weight, dimensions, and displacement of the complete kit and contents are as follows:

Shipping weight 124 pounds
Outside dimensions 48-1/4 x 16-1/2 x 16 inches
Displacement 7.3 cubic feet

69. M1A1 SERVICE KIT. (See figures 49, 50, 51, 52.) The chest of this kit is constructed much like that of the M1 service kit (see preceding paragraph). The contents, however, differ somewhat, as outlined in paragraphs 59, 60, and 61. The shipping weight, dimensions, and displacement of the complete kit and contents are as follows:

Shipping weight 140 pounds
Outside dimensions 48-1/4 x 16-1/2 x 16 inches
Displacement 7.3 cubic feet

70. FUEL FILLING KIT. (See figures 53, 54, 55.) This kit includes plywood and wood partitions and a tray. The shipping weight, dimensions, and displacement of the filling kit, including contents, are as follows:

Shipping weight 250 pounds
Outside dimensions 47 x 17 x 22-1/2 inches
Displacement 10.4 cubic feet

71. FUEL MIXING KIT. The items in this kit are nested within the packing case. The shipping weight, dimensions, and displacement of this kit, including contents, are as follows:

Shipping weight 65 pounds
Outside dimensions . . 31-1/2 x 20-1/2 x 17-3/4 inches
Displacement 6.5 cubic feet

SECTION XII

DESTRUCTION

72. PROCEDURE. When circumstances force the abandonment of chemical warfare materiel in the field, it is destroyed or rendered useless to prevent its use or study by the enemy. The following methods are recommended for the destruction of the portable flame thrower, its accessories and fuels.

a. Fuel unit and gun unit. One or more small arms bullets through the fuel tanks will prevent any immediate use of the flame thrower. Additional rounds may be put through the pressure and hydrogen cylinders, valves, and electrical system. If the cylinders are charged, the valves should be opened for a few seconds, thus permitting the contents to dissipate. This is necessary if rounds are to be fired point blank. If time permits, the gun may be rendered useless by bending or breaking it over a rock or other large, hard object. A fragmentation grenade, if available, will also achieve demolition.

b. Pressure and hydrogen filling apparatus. (1) The flexible tubing, gages, and valves may be destroyed by blows with an ax, sledge or other heavy instrument.

(2) The pressure and hydrogen cylinders are rendered useless by releasing the pressures and then destroying the valves by blows with an ax, sledge or similar instrument. Although the cylinders proper are made with heavy steel walls, they nevertheless can be destroyed by being stacked like cord-wood and each group of four demolished by the detonation of two 1/2-pound blocks of TNT in their midst.

c. Fuel, and fuel filling and mixing apparatus. (1) Gasoline and other fuels are destroyed by burning. Containers, pumps, and filling lines may be rendered useless by ax or sledge blows, or by small arms fire.

(2) NaPalm gasoline thickener is simply saturated with water.

APPENDIX

TECHNICAL EMPLOYMENT

1. SUPPORT. The flame thrower should not be used unsupported by other weapons. Sufficient flame throwers should be assigned to an operation to allow for casualties and possible malfunction of the weapon.

2. WHEN USED. The flame thrower is primarily an offensive weapon. Situations involving its use call for prior rehearsals. The shortness of firing time of the weapon requires that coordination be carried out to the split second. The flame thrower is not a weapon of opportunity.

3. REPLACEMENTS. No attempt to refill the flame thrower in the midst of combat should be made. Reserve operators should be available when needed to use other filled flame throwers. They will be used to replace operators who have become casualties or who have exhausted the contents of their flame throwers. Under some circumstances operators may be ordered to abandon their weapons when these have become exhausted.

4. OPERATING PERSONNEL. a. Definite individuals should be selected as flame thrower operators, should be thoroughly trained in its functioning, care and use, and each should be held personally responsible for his particular flame thrower. A flame thrower should not be issued to a soldier untrained in its operation with the idea of his using it immediately in combat. Such procedure will cause the failure of any operation centered around its use.

b. To provide assistance in handling the flame thrower and to provide protection for the operator, a two-man team is necessary for each weapon. The assistant operator should be as well trained as the operator.

5. **ATTACK OF A FORTIFIED POSITION.** The flame thrower has its principal tactical use in the attack of fortified localities, particularly in the reduction of permanent or semi-permanent emplacements. The flame thrower is used to provide last-minute, close-in protection for soldiers placing demolition charges or otherwise reducing the emplacement. One principal advantage of this weapon is the fact that the flame and smoke spread when they hit, fill the embrasure, and pour into ports and other apertures, while the operator can stand at an angle from which he cannot be seen from within the emplacement. Immediately before the operation starts, a last minute check of the flame thrower should be made by cracking the hydrogen valve, pressing the trigger safety key, and noting if the hydrogen burns. If possible, the trigger safety key should be pressed again just before the final assault of the pillbox.

6. **CHOICE OF FUELS.** (See paragraph 19.) a. The use of liquid fuel gives large volumes of smoke and flame, thus affording protection for the assault detachment. The large brilliant flame exercises a powerful demoralizing effect on the enemy, blinds them, and drives them away from their weapons with the heat. The flames and smoke roll and billow which in effect enables the flame thrower to "shoot around corners" from the blind angle. Liquid fuel is more easily transferred into the flame thrower tanks than is the thickened fuel. However, due to the shorter range the operator must approach closer to the target before opening fire. Final choice of fuel depends on the situation, such as the range and the angle at which the embrasure may be approached.

b. In the case of thickened gasoline the range is approximately two to three times as great and the operator can open fire at a greater distance. In addition more flaming fuel can be placed on the target than is possible with liquid fuel. The reason for this is that the liquid fuel is largely consumed in flight and is dispersed over a wider area, while thickened fuel issues in a narrow stream, can be spotted at any point on the target,

d will burn for several minutes. The burning thickened gaso-
 é sticks to clothing, skin, and weapons because of its glue-
 e consistency. However, little or no smoke is developed by
 e thickened fuel. Because of the decreased dispersion of the
 ckened fuel more skill is required to hit a small target, such
 an embrasure.

7. MOPPING UP. The flame thrower can be used well in
 opping up operations to smoke and burn enemy personnel out
 emplacements, dugouts, buildings, and other structures. The
 me thrower, using liquid fuel, fires a flame which rolls and
 flows into all cracks and corners. No corner of a dugout,
 om, or emplacement will provide protection from it. It is
 perior to hand grenades in this respect. Also, it can be fired
 to open doors, windows, or ports without getting into the angle
 fire from these openings because of its rolling effect. It is
 est to use liquid fuel for mopping up.

8. ANTI-MECHANIZED DEFENSE. The flame thrower is
 t particularly well adapted to anti-mechanized defense because
 the difficulty of having a limited number of flame throwers
 ere they are needed. If flame throwers should happen to be
 ere they are needed, they can be used to burn the rubber parts
 f of treads and wheels, they can be used to set engines on fire,
 ey will blind a tank (liquid fuel leaves a smudge on glass-cov-
 ed slits), and in some instances they will burn the men inside
 the tank.

9. INCENDIARY. The flame thrower can be used as an
 endiary against inflammable objects (airplanes, motors,
 mmunition), but it is not effective against objects with high
 ndling points.

10. DEMORALIZATION. Flame throwers used in large
 mbers in one locality are very demoralizing upon enemy troops
 th in the attack and in the defense.

11. **SIMULATING BURNING.** Using liquid fuel, flame throwers may be used upon decoys and dummies to deceive the enemy.

12. **TANK HUNTING.** The flame thrower may be used in tank hunting for the same purposes as mentioned in paragraph above.

13. **DEFENSE.** For the purposes described in paragraphs 8 and 10, the flame thrower may be valuable in the defense.

INDEX

	<u>Paragraphs</u>
adapter union	3 e
adjusting screw	4 <u>d</u>
adjusting screw seal	4 <u>d</u>
adjusting spring	4 <u>d</u>
adjusting spring button	4 <u>d</u>
aging of thickened gasoline	4 <u>3</u>
aiming	14
applications of flame thrower	2 a, 19, Appendix
battery, description of	6 c
battery, when to replace	49 a
"beattie" slide-ball valve	3 <u>g</u>
bends, fuel	28
body, pressure regulator	4 <u>d</u>
braces, fuel tank	3 a
burner, gas, cleaning of	47 c
burner, gas, description of	5 <u>h</u>
burner, gas, failure to ignite	5 <u>3</u>
burner guard	5 h
burner head	5 <u>h</u>
burner head, clogging of	53 <u>b</u>
carrier back	7 a
carrier, tank	2 b, 7
carrying the fuel unit	10
carrying the gun unit	11, 18 <u>g</u>
charging hydrogen cylinders	17 c, 33 - 36
charging pressure cylinders	17 c, 29 - 32
chest straps	7 d
cleaning of fuel system	17, 27, 47
clogging of hydrogen system	53 b
combustion chamber, fuel	5 <u>h</u>
compensating spring	4 <u>d</u>

	<u>Paragraphs</u>
Compressed air cylinders, precautions	44
Compression tee and tubing	5 <u>h</u>
Condenser	6 <u>e</u>
Connectors, fuel, valve, and hose	3
Cylinders, precautions	44
Demolition	72
Diaphragm assembly	4 <u>d</u>
Diesel oils	28
Diffuse pipe assembly	4 <u>e</u>
Dimensions, outside	66 - 71
Displacements	66 - 71
Drums, fuel mixing and shipping	24 <u>a</u> , 38, 42
Duration of fire	2 <u>f</u> , 8, Appendix
Electrical system, description of	6
Electrical system, failure of	53 <u>a</u>
Elevations	9, 14
Failure to ignite	53
Filling, fuel tanks	19 - 28
Filling kit, fuel	62, 70
Firing procedure	12, 15, 16, Appendix
Fuel, choice of	19, Appendix
Fuel combustion chamber	5 <u>h</u>
Fuel discharge valve, description of	2 <u>b</u> , 3 <u>g</u>
Fuel discharge valve, failure of	54, 55
Fuel filling	19 - 28
Fuel filling kit	62, 70
Fuel hose	2 <u>b</u> , 3 <u>f</u>
Fuel mixing apparatus, procured locally	64
Fuel mixing kit	63, 71
Fuel nozzle, description of	2 <u>b</u> , 3 <u>i</u>
Fuel oils	28, Appendix
Fuel system	3

	<u>Paragraphs</u>
Fuel tank braces	3 <u>a</u>
Fuel tank connector	3 <u>a</u>
Fuel tank plug	3 <u>a</u>
Fuel tanks, cleaning	27
Fuel tanks, description	3 <u>a</u>
Fuel tube	2 <u>b</u> , 3 <u>h</u>
Fuel unit, description	2 <u>b</u>
Fuel valve	2 <u>b</u> , 3 <u>c</u>
Funnel, fuel mixing	38 <u>c</u>
Funnel vent	39 <u>c</u>
Gas burner	5 <u>h</u> , 47 <u>c</u> , 53
Gasoline and thickened gasoline precautions	45
Gasoline, choice of	41 <u>a</u>
Guard cap, burner	5 <u>h</u>
Gun unit, description	2 <u>b</u>
Hose connector	3 <u>d</u>
Hose, fuel, cleaning	27 <u>b</u>
Hose, fuel, description	2 <u>b</u> , 3 <u>f</u>
Hydrogen cylinders, charging	33 - 36, 60 - 62
Hydrogen cylinder clamp	5 <u>b</u> , 5 <u>e</u>
Hydrogen cylinder, description	5 <u>a</u>
Hydrogen cylinders, precautions	44
Hydrogen cylinder valve	5 <u>c</u>
Hydrogen nozzle, blocking of	53 <u>b</u>
Hydrogen nozzle, description of	5 <u>h</u>
Hydrogen system, description of	5
Hydrogen system, failure of	53 <u>b</u>
Hydrogen trigger valve	5 <u>f</u>
Hydrogen tubing, steel	5 <u>e</u>
Hydrogen valve cap	5 <u>d</u>
Ignition chamber	5 <u>h</u>
Ignition failure	53
Inlet adapter and nut	4 <u>d</u>
Inlet screen, pressure regulator	4 <u>d</u>

	<u>Paragraphs</u>
Inside sleeve	5 <u>h</u>
Kerosene	28 <u>b</u>
Kneeling position	13 <u>a</u>
Leakage from fuel discharge valve	54, 55
Leaking cylinders	57
Leaking hydrogen trigger valve	58
Leaks, testing for	48 <u>a</u> , 57
Liquid fuel, filling	28 <u>c</u>
Liquid fuel, types	28 <u>b</u>
Liquid fuel, uses	19, 28, Appendix
Lumpy fuel	43
Manifold, pressure, hydrogen	33 - 36
Manifold, pressure, nitrogen or compressed air	29 - 32
Mixing apparatus, fuel, procured locally	64
Mixing kit, fuel	63, 71
M1, how differs from M1A1	2 <u>b</u>
M1A1, how differs from M1	2 <u>b</u>
NaPalm gasoline thickener, how used	39, 40, 41
Nitrogen cylinder and valve	4 <u>a</u> , <u>b</u> , <u>c</u> , 60 - 62
Nitrogen cylinders, precautions	44
Nozzle, fuel, damage to	48 <u>c</u>
Nozzle, fuel, description of	2 <u>b</u> , 3 <u>i</u>
Nozzle, hydrogen	5 <u>h</u>
Nozzle, pressure regulator	4 <u>d</u>
Oil hose (fuel hose)	3 <u>f</u>
Oil tube (fuel tube)	3 <u>h</u>
Oils, fuel and Diesel	28
Operating pin, pressure regulator	4 <u>d</u>
Outer chamber	5 <u>h</u>

	<u>Paragraphs</u>
Outside dimensions	66 - 71
Outside sleeve	5 <u>h</u>
Oxygen, how to recognize	29 <u>c</u>
Paddle, fuel mixing	38 <u>e</u>
Pails, fuel mixing	38 <u>d</u>
Period of fire	2 <u>f</u> , 8
Pipe, suction	22 <u>a</u>
Positions, firing	13
Precautions	18, 44, 45, Appendix
Preparing thickened gasoline	37 - 43
Pressure cylinder clamp	4 <u>b</u>
Pressure cylinder valve	4 <u>c</u>
Pressure cylinders, description	2 <u>b</u> , 4 <u>a</u>
Pressure cylinders, precautions	44
Pressure, insufficient	56
Pressure manifold for filling cylinders	29 - 32, 60 - 62
Pressures, recommended, for cylinders, fuel tanks	4 <u>e</u>
Pressure regulator, adjustment of	51
Pressure regulator, adjustment	19 <u>b</u> , 51
Pressure regulator, description of	4 <u>d</u>
Pressure regulator, replacement of	49 <u>c</u>
Pressure system	4
Prone position	13 <u>b</u>
Push button switch	6 <u>a</u>
Pump, force	21, 22, 23, 27
Range, failure to obtain sufficient	56
Ranges, effective and maximum	2 <u>c</u> , 9
Relief valve	4 <u>d</u>
Scale, spring	38 <u>c</u>
Service kit, M1	60, 68
Service kit, M1A1	61, 69
Shipping weights	66 - 71

	<u>Paragraphs</u>
Shoulder straps	7 <u>b</u>
Spark coil	6 <u>g</u>
Spark generator, description of	6
Spark generator, replacement of	53 <u>a</u>
Spark generator case	6 <u>d</u>
Spark generator housing	6 <u>b</u>
Spark interrupter	6 <u>f</u>
Spark, lack of	53 <u>a</u>
Spark plug, cleaning of	53 <u>a</u>
Spark plug, description of	6 <u>h</u>
Spark plug, replacement of	49 <u>b</u> , 53 <u>a</u>
Spider	4 <u>d</u>
Spring case, pressure regulator	4 <u>d</u>
Standing position	13 <u>c</u>
Storage	17 <u>e</u> , 52
Tank carrier	2 <u>b</u> , 7
Temperature, effect on mixing fuel	40 <u>a</u> , 41 <u>d</u>
Thickened gasoline, care of	39 <u>a</u>
Thickened gasoline, inspection of	19
Thickened gasoline, preparation of	37 - 43
Thickened gasoline, uses of	19, Appendix
Trigger assembly	2 <u>b</u> , 5 <u>f</u> , 6 <u>c</u> , 50
Trigger safety key	5 <u>f</u> , 50
Trigger valve	5 <u>f</u>
Tubing, copper, for fuel filling	39 <u>c</u>
Tubing, hydrogen	5 <u>e</u> , 5 <u>g</u> , 5 <u>h</u>
Uses of flame thrower	2 <u>a</u> , 19, Appendix
Valve connector	3 <u>b</u>
Valve seat, pressure regulator	4 <u>d</u>
Waist straps	7 <u>c</u>
Weight, gun unit	2 <u>d</u>

PORTABLE FLAME THROWERS, M1 AND M1A1 TM 3-375

Paragraphs

Weights, flame thrower, empty and filled	2 <u>d</u>
Weights, fuel unit, empty and filled	2 <u>d̄</u>
Weights, shipping	66 - 71
Windage	9, 18 <u>k</u>
Y-valve	3 <u>g</u>

[A. G. 062.11 (2-15-43).]

BY ORDER OF THE SECRETARY OF WAR:

G. C. MARSHALL,
Chief of Staff.

OFFICIAL:

J. A. ULIO,
Major General,
The Adjutant General.

DISTRIBUTION:

R and H (5) ; IC 3 (5) ; IC 2, 5, 7 (15).
(For explanation of symbols see FM 21-6.)

U. S. GOVERNMENT PRINTING OFFICE: 1943 O - 524664

