

TM 9-1900

WAR DEPARTMENT

TECHNICAL MANUAL



AMMUNITION, GENERAL

July 3, 1942

## AMMUNITION, GENERAL

	Paragraphs
CHAPTER 1. General.	
SECTION I. Introduction-----	1-3
II. General discussion-----	4-12
III. Propellants-----	13-23
IV. High explosives-----	24-34
V. Chemical agents-----	35-39
CHAPTER 2. Basic types of ammunition.	
SECTION I. Small-arms ammunition-----	40-57
II. Grenades-----	58-64
III. Antitank mines-----	65-70
IV. Mortar ammunition-----	71-75
V. Artillery ammunition-----	76-87
VI. Bombs-----	88-98
VII. Pyrotechnics-----	99-110
CHAPTER 3. Care, handling, and preservation.	
SECTION I. General safety precautions-----	111-113
II. Storage-----	114-118
III. Inspection and surveillance-----	119-132
IV. Packing and marking-----	133-139
V. Shipping-----	140-144
VI. Precautions for practice firing-----	145-153
VII. Ammunition in harbor defenses-----	154
VIII. Ammunition at supply points-----	155-157
CHAPTER 4. Destruction of unserviceable ammunition-----	158-173
	Page
APPENDIX I. Glossary-----	182
II. Abbreviations-----	194
III. List of references-----	197
INDEX-----	200

\*This manual supersedes TM 9-1900, September 8, 1941, including Training Circulars Nos. 11 and 12, War Department, 1942.

## CHAPTER 1

## GENERAL

	Paragraphs
SECTION I. Introduction.....	1-3
II. General discussion.....	4-12
III. Propellants.....	13-23
IV. High explosives.....	24-34
V. Chemical agents.....	35-39

## SECTION I

## INTRODUCTION

	Paragraph
Purpose.....	1
Scope.....	2
References.....	3

1. **Purpose.**—*a.* This manual is published for the information and guidance of all Army personnel having to do with ammunition. Those responsible for the handling of ammunition should become thoroughly familiar with its provisions.

*b.* The requirements of this manual are applicable to all Army posts, camps, and other stations, except ordnance establishments under the direct control of the Chief of Ordnance, where the requirements of the Ordnance Safety Manual (O. O. Form 7224) will govern.

2. **Scope.**—The information contained herein is of a general technical nature. It concerns the several types of ammunition, their general characteristics, means of identification, care in handling and use, storage and maintenance, surveillance and grading, packing and marking, shipping, and the destruction of duds and unserviceable ammunition. Further information concerning specific types of ammunition is contained in Technical Manuals and Field Manuals dealing with the weapon in which the ammunition is used, or, in the case of ammunition such as bombs and grenades which do not require a weapon, this information is contained in Technical Manuals pertaining to these types.

3. **References.**—Publications containing additional information, referred to in the text, and other pertinent references are included in appendix III.

## SECTION II

## GENERAL DISCUSSION

	Paragraph
General.....	4
Nomenclature.....	5
Classification.....	6
Identification.....	7
Painting and marking.....	8
Grading.....	9
Priority of issue.....	10
Care and preservation.....	11
Packing and marking for shipment.....	12

4. **General.**—*a.* The term “ammunition” as used herein, unless otherwise limited, will be understood to include all military ammunition and components thereof. It applies to missiles dropped or thrown by hand, and pyrotechnics, as well as projectiles propelled by a charge of powder.

*b.* Depending upon its general characteristics and methods of use, ammunition is grouped into the following basic types:

(1) Small-arms ammunition—cartridges and shotgun shells used in small-arms weapons.

(2) Grenades—explosive and chemical missiles thrown by hand or projected by rifles, guns, or special projectors.

(3) Antitank mines—explosive mines usually laid in advance positions as protection against mechanized attack.

(4) Mortar ammunition—explosive and chemical ammunition used in mortars commonly known as trench mortars.

(5) Artillery ammunition—explosive and chemical ammunition used in cannon of all calibers.

(6) Bombs—explosive and chemical missiles designed for release from aircraft.

(7) Pyrotechnics—ammunition designed to produce brilliant or colored lights for illumination or signaling.

5. **Nomenclature.**—Standard nomenclature is established in order that each of many items supplied by the Ordnance Department may be specifically indentified by name. These names are published in Standard Nomenclature Lists (SNL's). The nomenclature for ammunition items is published in SNL groups P, R, S, and T. For all purposes of record, the use of this nomenclature is mandatory. Standard nomenclature is used herein in all references to specific items of issue. Examples of representative nomenclature are—

Cartridge, ball, caliber .30, M2.

Shell, fixed, HE, M41, with fuze, PD, M48, 75-mm gun.

Shell, semifixed, HE. M41, with fuze, PD, M48, 75-mm pack howitzer M1 and M1A1.

Shell, HE, M102, unfuzed, 155-mm howitzer (adapted for fuze, PD, M51 or M55, with booster M21).

Charge, propelling, M1 (green bag), 155-mm howitzer M1917-18.

Bomb, demolition, 100-pound, M30, unfuzed (adapted for nose fuze M103 and tail fuze M100 or M106).

**6. Classification.**—*a.* Ammunition is classified according to use as service, practice, blank, or drill. Ammunition may also be classified according to the kind of filler, as explosive, chemical, or inert.

*b.* Service ammunition is that which is used for effect. Such ammunition (except small-arms ammunition) usually has a high explosive or chemical filler.

*c.* Practice ammunition is provided for training in marksmanship. This type may have a small quantity of low explosive filler to serve as a spotting charge, or the filler may be inert.

*d.* Blank ammunition is provided for saluting purposes and for simulated fire. It has no projectile.

*e.* Drill or dummy ammunition is used for training in handling and loading (service of the piece), and similar purposes. It is completely inert.

**7. Identification.**—*a. General.*—Every item of ammunition is completely indentified by the painting, marking (which includes the ammunition lot number), and accompanying data cards or tags. For purposes of record the standard nomenclature of the item, together with its lot number, completely identifies the ammunition. Included in both the marking and the standard nomenclature are—

(1) A brief description of the type or suitable abbreviation thereof.

(2) Caliber, weight, or size.

(3) Model designation.

(4) Where required, such additional information as the model and type of fuze, the model of the cannon in which the item is fired, the weight of projectile for which a separate loading propelling charge is suited, etc.

(5) The lot number is marked on the ammunition but is not a part of the nomenclature. However, when referring to specific ammunition, it is necessary to mention the lot number as well as the standard nomenclature.

*b. Model.*—To distinguish a particular design, a model designation is assigned at the time the model is classified as an adopted

type. This model designation becomes an essential part of the standard nomenclature and is included in the marking on the item. Prior to the World War, the year in which the design was adopted, preceded by an M, was used as the model designation, for example, M1906. From the World War until July 1, 1925, it was the practice to assign mark numbers. The word "Mark," abbreviated "Mk.," was followed by a roman numeral, for example, shell, HE, Mk. III. The first modification of a model was indicated by the addition of MI to the mark number, the second by MII, etc. The present system of model designation consists of the letter M followed by an arabic numeral. Modifications are indicated by adding the letter A and appropriate arabic numerals. Thus M2A1 indicates the first modification of an item for which the original model designation was M2. Certain items standardized for use by both Army and Navy are designated by the letters AN preceding the model designation, for example, AN-M100A1, AN-Mk. 19.

*c. Ammunition lot number.*—When ammunition is manufactured an ammunition lot number, which becomes an essential part of the marking, is assigned in accordance with pertinent specifications. This lot number is stamped or marked on every item of ammunition unless the item is too small, on all packing containers, and on the accompanying ammunition data card or tag. It is required for all purposes of record, including reports on condition, functioning, and accidents in which the ammunition is involved. To provide for the most uniform functioning, all of the components in any one lot are manufactured under as nearly identical conditions as practicable. For example, in the case of fixed ammunition, all of the rounds in any one lot consist of—

- (1) Projectiles of one lot number (one type and one weight zone).
- (2) Fuzes of one lot number.
- (3) Primers of one lot number.
- (4) Propellant powder of one lot number.

*d. Ammunition data card.*—A 5- by 8-inch card printed with pertinent information and data concerning the item and its components, known as an ammunition data card, is packed in each packing box with the ammunition or, in the case of bundle packing, in each fiber container. When required, assembling and firing instructions are printed on the reverse side of the card. On recent shipments, the data cards are not packed with the ammunition and only a limited quantity are forwarded with the shipping tickets.

**8. Painting and marking.**—*a. Painting.*—Ammunition is painted to prevent rust and to provide, by means of color, a ready means of identification as to type. The color scheme is as follows:

(1) For other than bombs and small-arms ammunition:

<i>Type</i>	<i>Base color</i>	<i>Marking</i>
High explosive	Yellow	Black
Low explosive	Red	Black
Chemical	Gray	Green, red, yellow, or purple, according to kind of filler
Practice	Blue	White
Dummy (inert)	Black	White

(2) For bombs, the color scheme has been the same as above. A new color scheme has been adopted and bombs of recent manufacture and those to be stored in the open (except chemical bombs) will be painted olive drab, lusterless, with 1-inch colored bands appearing at the nose and tail ends of the body and a  $\frac{1}{4}$ -inch interrupted band at the center of gravity. The color of the bands will be as follows:

Bombs containing a high-explosive filler (demolition, general purpose, fragmentation)	Yellow
Practice	Blue
Drill or inert	Black

Chemical bombs will be painted gray and marked in accordance with the old color scheme.

(3) For small-arms ammunition, cartridges do not require painting. The packing boxes, however, are painted brown with marking in yellow, and have a distinctive color band, as follows:

<i>Type</i>	<i>Band</i>
Ball	Red
Blank	Blue
Dummy	Green
Guard	Orange
Gallery practice	Brown
High-pressure test	Yellow
Tracer	Green on yellow
Armor-piercing	Blue on yellow
Ball and tracer	Yellow, red, green (3 stripe band)

*b. Marking.*—The marking stenciled or stamped on the ammunition and on its packing containers includes all information necessary for complete identification. Further information concerning painting and marking will be found under the specific type in chapter 2 and in section IV, chapter 3.

9. Grading.—*a.* Ammunition is manufactured to rigorous specifications and thoroughly inspected and tested before acceptance.

In accordance with the results of these tests, each lot of ammunition is assigned a grade. Ammunition in storage is periodically retested to insure that its characteristics have not changed. If changes have occurred, the ammunition is regraded.

*b.* Each lot of small-arms ammunition is graded primarily on the qualities which make that lot especially suitable for use in a particular class of small-arms weapons. See Ordnance Field Service Bulletin No. 3-5.

*c.* Each lot of ammunition other than small-arms is graded as a result of surveillance tests. See Ordnance Field Service Bulletin No. 3-1.

**10. Priority of issue.**—*a.* Subject to special instructions from the Chief of Ordnance, ammunition of appropriate type and model will be used in the following order: limited standard, substitute standard, standard. Within this rule, ammunition which has had the longest or least favorable storage will be used first. Among lots of equal age, priority will be given to the smallest lot.

*b.* To prevent the building up of excess stocks in the field, transfers may be arranged within the corps area if no stock of appropriate grade for immediate use is on hand.

*c.* Priority of issue for lots of small-arms ammunition is established by the Chief of Ordnance and published in Ordnance Field Service Bulletin No. 3-5, or in special instructions.

*d.* Further details will be found in the Ordnance Field Service Bulletins, Series 3, and in AR 775-10.

**11. Care and preservation.**—*a.* In order to keep ammunition in a serviceable condition, ready for immediate issue and use, due consideration should be given to the following:

*b.* Ammunition should be stored in the original containers, in a dry, well-ventilated place, protected against the direct rays of the sun and other sources of excessive heat.

*c.* Ammunition and its containers should be kept clean and dry and protected from damage.

*d.* Components of ammunition should not be disassembled without specific authorization.

*e.* Sealed containers should not be opened nor protective or safety devices removed until just before use.

*f.* Ammunition prepared for firing but not fired should be returned to its original packing and appropriately marked. Such ammunition should be used first in subsequent firings in order that stocks of opened packings may be kept at a minimum.

**12. Packing and marking for shipment.**—*a.* Ammunition is packed and marked in accordance with pertinent specifications and drawings.



*b.* Packings for ammunition are designed to withstand all conditions ordinarily encountered in handling, storage, and transportation and to comply with Interstate Commerce Commission regulations.

*c.* Marking includes all information required—

(1) For complete identification of contents.

(2) By the Interstate Commerce Commission for shipping, including addresses of consignor and consignee and shipping designation of the contents.

*d.* Further information concerning packing and marking is contained in section IV, chapter 2.

### SECTION III

## PROPELLANTS

	Paragraph
General .....	13
Explosive train .....	14
Classification .....	15
Smokeless powder .....	16
Pyro powder .....	17
Double-base powder .....	18
FNH and NH powder .....	19
Guncotton .....	20
E. C. smokeless powder .....	21
Small-arms propellants .....	22
Black powder .....	23

**13. General.**—Explosives of one kind or another are a fundamental part of all ammunition. For military purposes, explosives are divided into two basic groups, propellants and high explosives. One of the chief differences between these groups is the rapidity with which the explosion occurs. Propellants explode at a relatively slower rate than high explosives. High explosives detonate almost instantaneously. Propellants comprise those explosives which are used principally for propelling projectiles from guns. They are described in this section. High explosives comprise those used principally as filler or bursting charge for explosive components such as projectiles, bombs, and grenades, and also those used as initiators. They are described in section IV. Further information concerning properties, methods of manufacture, etc., will be found in TM 9-2900.

**14. Explosive train.**—A series of explosives beginning with a small amount of sensitive explosive and terminating with a large amount of comparatively insensitive explosive is termed an explosive train. In general there are two such trains, the propelling charge explosive train and the bursting charge explosive train. The propelling charge explosive train usually consists of primer, igniter or

igniting charge, and propelling charge. Thus a spit of fire from a small quantity of sensitive explosive (the primer) is transmitted and intensified (by igniter) to the end that a large quantity of relatively insensitive explosive (the propelling charge) burns in the manner required to project the projectile properly. In some instances, such as small-arms cartridges, where the propelling charge is relatively small, the igniter is not required. The bursting charge explosive train is described in section IV.

**15. Classification.**—All explosives currently used as propellants have a nitrocellulose base and are commonly known as smokeless powders. Various organic or inorganic substances are added to the nitrocellulose base during manufacture to give improved qualities for special purposes. These powders are distinguished by such terms as double-base powder; flashless-nonhygroscopic, FNH; and nonhygroscopic, NH; as well as commercial trade names or symbols. A straight nitrocellulose powder is known as pyro powder. Black powder as a propellant has been almost completely superseded by smokeless powder.

**16. Smokeless powder.**—*a. Characteristics.*—Smokeless powder is not entirely smokeless and it is not a powder. It is manufactured in the form of flakes, strips, pellets, or perforated cylindrical grains. The cylindrical grains are made with varying diameters and lengths. The critical dimension is the web size, that is, the average thickness of the powder between the perforations. In color, the grains vary from a light amber to a deep brown or black. Figure 1 illustrates typical grains. Strip powder may be used as a satisfactory substitute for perforated cylindrical grains in time of emergency.

*b. Burning action.*—Unconfined smokeless powder burns like celluloid with little ash or smoke, but when confined its rate of burning increases with temperature and pressure. Figure 2 shows the manner in which the grains burn.

*c. Solvent.*—Smokeless powder is manufactured to contain in the finished grains a definite amount of solvent (an ether and alcohol mixture). If there is a marked change in the amount of solvent, a change in ballistic properties will result. Powder must be carefully protected against high temperatures, moisture, and changes in temperature. To guard against changes due to such conditions, smokeless powder is always packed in airtight containers.

*d. Use.*—Nitrocellulose smokeless powder is used as the propellant for small-arms and larger caliber ammunition. The perforated form of grain is the one most commonly used in United States military powders. Single perforated grains are used for small arms, minor caliber cannon, and certain howitzers. Powders with seven

perforations are used for larger caliber weapons. See figure 3 for examples.

17. **Pyro powder** (straight nitrocellulose powder).—For many years the standard powders in service were of the straight nitrocellulose type. Commonly referred to as pyro powder or pyrocellulose, it is now largely used as a substitute standard for the FNH and NH powders. A disadvantage is the production of muzzle flash in firing. It is also hygroscopic and has relatively low potential.

18. **Double-base powder**.—The term double-base powder has been applied to powders containing both nitrocellulose and nitroglycerin, the nitroglycerin serving to increase the potential. Small percentages of inorganic salts are often added, serving to reduce flash and make the powder more ignitable. Ballistite is a typical nitroglycerin powder and is used in 12-gage shotgun shell and in 3-inch mortar ammunition.

19. **FNH and NH powder**.—Flashless-nonhygroscopic (FNH) powders are mixtures of nitrocellulose and other materials which are added in order to cool the products of combustion, thereby reducing the flash. These added materials also reduce hygroscopicity, that is, tendency to absorb moisture. They are used in propellants for most guns and howitzers of 37-mm and larger caliber. FNH powder may be flashless in one weapon and yet not completely flashless in another. When FNH powder is designated to be used with weapons in which flash occurs, it is termed NH powder. Nitroglycerin is used in certain FNH powders for small cannon, in trench mortar propellants where especially rapid burning is required, and in certain high velocity ammunition.

20. **Guncotton**.—Guncotton, a nitrocellulose of high nitration, is used in the manufacture of FNH powders. Small wisps of dry guncotton are used as flame carriers in the central tube of shrapnel to connect the fuze with the base charge. It is also used in electric primers.

21. **E. C. smokeless powder**.—E. C. smokeless powder, or E. C. blank fire, consists of nitrocellulose with inorganic nitrates. It is usually orange or pink in color and resembles coarse sand, though it is soft and light. It is sensitive to friction, shock, or heat. It absorbs moisture readily and so must be protected from the atmosphere. It is usually exploded by flame from a primer or fuze. It burns extremely rapidly in the open, but explodes if confined. It is used as a bursting charge in fragmentation hand grenades. It is also used in caliber .30 and caliber .50 blank cartridges.

22. **Small-arms propellants**.—Smokeless powder for small arms differs from that used for cannon in that it is usually glazed with

graphite to facilitate machine loading and thus presents a black polished appearance. Since the powder grains are small, they ignite more readily and burn more freely than cannon powder; and when moisture is present or abnormal temperature prevails, they are subject to more rapid deterioration than the larger grains. Small-arms powders, like cannon powders, are packed in airtight containers. Many small-arms powders are nearly as sensitive as black powder to friction. Therefore, all precautions used in handling black powder should be observed for small-arms powders. In general, there are two types of small-arms propellants, the single-base pyrocellulose type and the double-base type.

**23. Black powder.**—*a. General characteristics.*—Black powder is an intimate mechanical mixture of finely pulverized potassium or sodium nitrate, charcoal, and sulfur. The commercial blasting powder with sodium nitrate is now used for saluting charges. Potassium nitrate is used in the powders for all other military purposes. Black powder is usually in the form of small black grains which are polished by glazing with graphite. It is subject to rapid deterioration in the presence of moisture, but if kept dry retains its explosive properties indefinitely. It is one of the most dangerous explosives to handle because it is so easily ignited by heat, friction, or spark.

*b. Uses.*—As a propellant, black powder has been superseded almost entirely by smokeless powder. Its present military use, in its several grades, is practically confined to—

- (1) Ignition charges.
- (2) Base charges, or expelling charges, for shrapnel.
- (3) Pellets for primers and fuzes.
- (4) Blank ammunition charges.
- (5) Smoke-puff charges.
- (6) Bursting charges for practice bombs, shell, and subcaliber shell.
- (7) Time-train rings and combination fuzes.

*c. Precautions.*—Black powder is particularly sensitive to flame or spark. When handling black powder in cans or bags or when it is not absolutely protected against sparks, the precautions described in section I, chapter 3, will be strictly observed.

## SECTION IV

### HIGH EXPLOSIVES

	Paragraph
General .....	24
Explosive train.....	25
Trinitrotoluene (TNT).....	26
Amatol.....	27

AMMUNITION, GENERAL

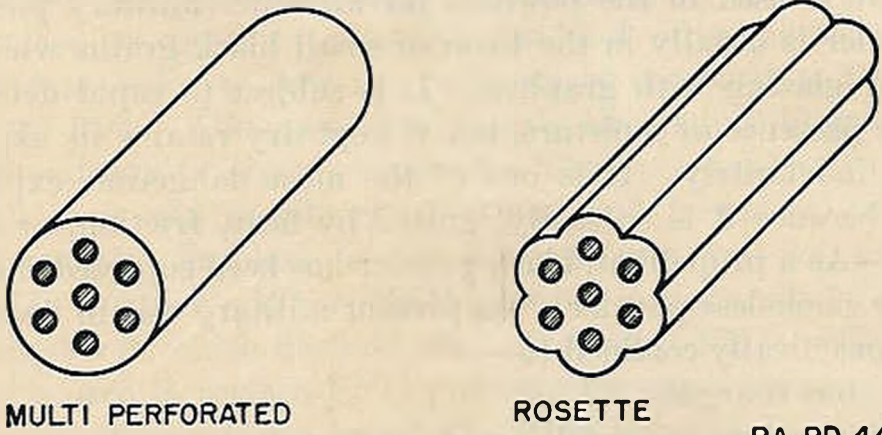
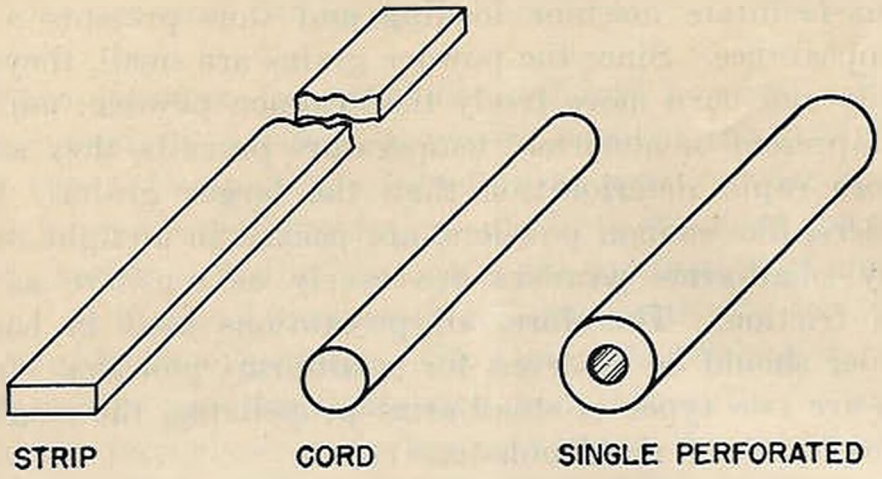

RA PD 4442

FIGURE 1.—Types of powder grains.

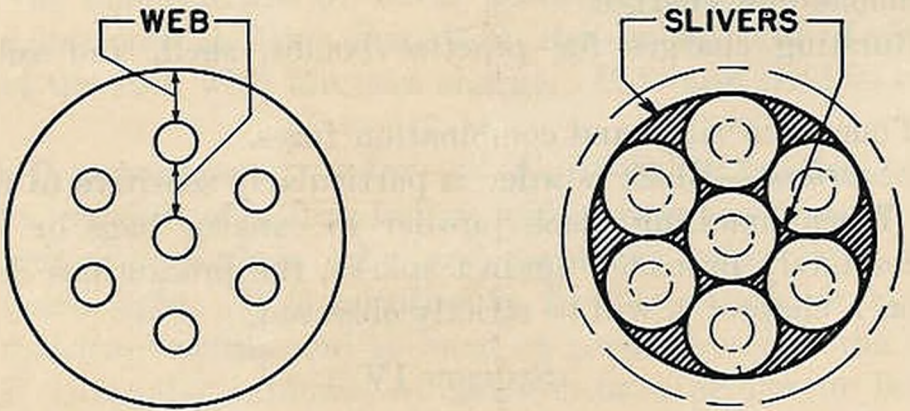

RA PD 4319

FIGURE 2.—Burning of powder grains.

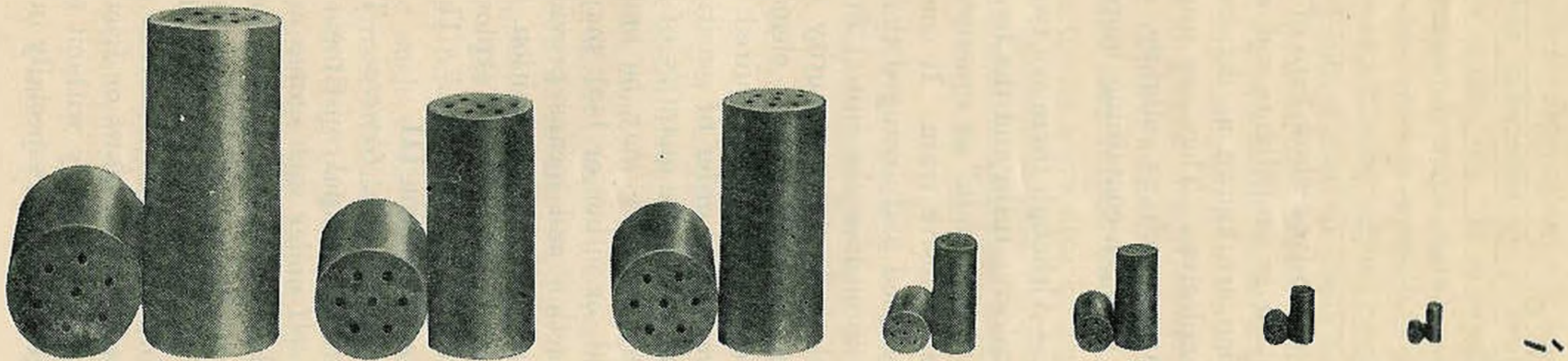

FIGURE 3.—Side and end views of typical powder grains (approximately half size).

RA PD 4443

	Paragraph
Ammonium picrate (explosive D)-----	28
Picric acid (trinitrophenol)-----	29
Nitrostarch explosives-----	30
Tetryl-----	31
Mercury fulminate-----	32
Lead azide-----	33
Miscellaneous explosives-----	34

**24. General.**—Those explosives whose rate of decomposition is so high as to preclude their use as propellants and which bring about a powerful disruptive action are known as detonating explosives or, more commonly, high explosives. They are usually nitration products of organic substances such as cellulose, starch, or coal tar derivatives but may be nitrogen-containing inorganic substances or mixtures of both.

**25. Explosive train.**—Although there are two explosive trains—the propelling-charge explosive train and the bursting-charge explosive train—the term “explosive train” as commonly used is intended to mean bursting-charge explosive train. It consists of a series of explosive elements so designed and arranged that each element successively transmits and intensifies the initial fire from the primer to the end that the relatively large quantity of bursting charge detonates in the desired manner. These elements are usually a primer, time or delay element where required, detonator, booster, and bursting charge, arranged in order of sensitivity—a small quantity of sensitive explosive to a large quantity of less sensitive explosive. The time or delay elements may be omitted when “superquick” action is required, or either or both may be combined in a fuze, with superquick action and means provided for setting the fuze just before use. In chemical ammunition, the bursting charge is replaced by a chemical agent, and the explosive element (which resembles a booster) is called the “burster.” The propelling-charge explosive train is described in section III.

**26. Trinitrotoluene (TNT).**—*a. General.*—Trinitrotoluene, commonly known as TNT, is the principal constituent of many explosives, and has been used by itself under such names as triton, trotyl, tolite, trilit, trinol, tritolo. It is the Army’s most important high explosive.

*b. Characteristics.*—TNT is one of the most stable of high explosives, and can be stored over long periods of time when properly purified. It is relatively insensitive to blows or friction. When ignited by flame in the open it burns rapidly without explosion. Burning or rapid heating of large quantities, especially in closed vessels, may,

however, cause violent detonation. It has powerful brisant properties. It is readily detonated by mercury fulminate, tetryl, and other similar high explosives. It is nonhygroscopic and does not form sensitive compounds with metal. It usually resembles light brown sugar but when pure is crystalline and has a very pale straw color. It is a very satisfactory military explosive because it is easily melted and poured into a shell or bomb to form a solid crystalline explosive charge. Ammunition loaded with TNT can be stored, handled, and shipped with comparative safety.

*c. Exudation.*—Some ammunition loaded with TNT when stored in warm climates or during warm summer months may exude an oily brown liquid. This exudate oozes out around the threads at the nose of the shell, and may form a pool on the floor. Exuding shell should be reported to the corps area or department ordnance officer, who will give the necessary instruction for their use or disposition. The exudate is inflammable and may carry small particles of TNT. Pools of exudate should be removed by scrubbing the floor with hot water.

*d. Detonation.*—TNT in crystalline form detonates readily under the influence of a No. 6 detonator and, when highly compressed, of a No. 8 detonator. When cast, it is necessary to use a booster charge of pressed tetryl, or an explosive of equal brisance, to insure complete detonation.

*e. Use.*—(1) *Bursting charge.*—TNT is used as a bursting charge for high explosive shell, alone or mixed with ammonium nitrate to form 50/50 or 80/20 amatol. Flake TNT is used in 37-mm shell. Other military uses of TNT are as a bursting charge for bombs, anti-tank mines, for parts of certain shell and bomb boosters, and as a constituent of propellant powder.

(2) *Demolition.*—TNT is used to demolish bridges, railroads, and other structures and for land mines placed under enemy trenches or fortifications. For such work TNT is made up in the form of a small, highly compressed block enclosed in a fiber container which protects it from crumbling in handling and renders it waterproof. The triton blocks used by the Corps of Engineers are blocks of pressed TNT, enclosed in a cardboard container.

(3) *Blasting.*—It is suitable for all types of blasting where 40 percent dynamite is used.

(4) *Detonating fuze.*—Primacord Bickford is the trade name for a detonating fuze which consists of a flexible fabric tube filled with high explosive.

**27. Amatol.**—*a. General characteristics.*—Amatol, a mechanical



mixture of ammonium nitrate and TNT, has approximately the same general characteristics as TNT. It is crystalline and yellow or brownish, moisture-absorbing, insensitive to friction, but may be detonated by severe impact. It is readily detonated by mercury fulminate and other high explosives. It has no tendency to form dangerous compounds with metals, except copper and tin, and is less likely to exude than is TNT. It absorbs moisture and corrodes booster casings and threads when moist. Amatol, 50/50, has approximately the same rate of detonation and brisance as TNT. Amatol, 80/20, produces a white smoke on detonation; and amatol, 50/50, a smoke less black than straight TNT.

*b. Composition and form.*—Amatol, 50/50, consists of 50 percent, by weight, ammonium nitrate and 50 percent TNT; it is sufficiently fluid when hot to be poured or cast like TNT. Amatol, 80/20, consists of 80 percent ammonium nitrate and 20 percent TNT. It resembles wet brown sugar and when hot is a plastic material and is so pressed into shells and bombs.

*c. Use.*—Amatol is a substitute for TNT. Amatol, 50/50, is used for shell of 3-inch caliber and larger and 80/20 amatol for shell of 155-mm and larger. Amatol is also used in large bombs.

**28. Ammonium picrate (explosive D).**—*a. Characteristics.*—Ammonium picrate is the least sensitive of military explosives to shock and friction, which makes it well suited for use as a bursting charge in armor-piercing projectiles. It is slightly inferior in explosive strength to TNT. It does not melt but decomposes when heated and explodes. It reacts with metals slowly and when wet it can form sensitive and dangerous picrates with copper and lead. It is difficult to detonate but burns readily like tar or resin.

*b. Special precautions.*—(1) Ammonium picrate which has been pressed at a shell-loading plant and removed from a shell is very much more sensitive to shock or a blow than new material. It should be protected against shock or fire, and it should preferably be stored in a building by itself.

(2) Although less sensitive than TNT, it can be exploded by severe shock or friction, is highly inflammable, and when heated to a high temperature may detonate.

*c. Use.*—Explosive D is used as a bursting charge for all armor-piercing shell, in projectiles for seacoast cannon, and in other types of projectiles which must withstand severe shocks and stresses before detonating.

**29. Picric acid (trinitrophenol).**—*a. Characteristics.*—Picric acid is a lemon-yellow crystalline solid. It is entirely stable, but

the presence of any trace of explosives which detonate more readily, such as metallic picrates, may cause sudden detonation of burning picric acid. It has about the same sensitivity to shock as TNT and is somewhat more readily detonated by means of a detonator. It is one of the most powerful military explosives.

*b. Use.*—Introduction of TNT as a military explosive has resulted in a gradual abandonment of the use of picric acid. It is used for conversion into ammonium picrate, as a booster explosive, and even as a substitute for part of the mercury fulminate charge in detonators. Picric acid has been used extensively in the form of mixtures with other nitro compounds.

**30. Nitrostarch explosives.**—*a. General.*—(1) Nitrostarch is a white, finely divided material similar in appearance to ordinary powdered starch. It is more sensitive to impact than TNT but less sensitive than dry guncotton or nitroglycerin. It is highly inflammable, being readily ignited by the slightest spark such as may result from friction, and it burns with explosive violence.

(2) Nitrostarch explosives are readily detonated by mercury fulminate detonators, a No. 6 detonator producing complete detonation unless the explosive has been rendered unduly insensitive by excessive absorption of moisture or by other cause.

(3) A nitrostarch demolition explosive has recently been adopted as a substitute for TNT. It is consolidated into 1/2-pound and 1-pound (four 1/4-pound) blocks and in comparison tests it has been found that the TNT formulas for computing small charges are directly applicable to the nitrostarch demolition explosive. Nitrostarch blocks must not be broken into fragments as this may cause detonation.

*b. Use.*—Nitrostarch may be considered as a substitute for TNT in emergencies when there is a shortage of toluene for making TNT. During the World War, nitrostarch was used in the following form:

- (1) Trojan grenade explosive.
- (2) Trojan trench mortar shell explosive.
- (3) Grenite.

**31. Tetryl.**—*a. General.*—Tetryl is the standard booster explosive. It is a yellow crystalline solid. When heated it first melts and then decomposes and explodes. It burns readily and is more easily detonated than TNT or ammonium picrate, being about as sensitive as picric acid. It is detonated by friction, shock, or spark. It is practically nonhygroscopic. It is stable at all temperatures which may be encountered in storage.

*b. Detonation.*—Brisance tests show tetryl to have greater shatter-

ing ability than any other military high explosive. Picric acid and TNT come second and third in brisance, respectively.

*c. Use.*—(1) *Charges.*—Tetryl is sufficiently insensitive when compressed into a booster to be safely used as a booster explosive. The violence of its detonation insures a high order of detonation of the bursting charge. It is used in the form of pressed pellets. Tetryl has been approved as the standard bursting charge for small-caliber projectiles. It gives appreciably better fragmentation to these shell than TNT. It is also more readily detonated and yet, in small-caliber shell, withstands the force of set-back.

(2) *Detonator.*—Tetryl is also used in detonators as a base charge, the tetryl being pressed into the bottom of the detonator shell and then covered with a small priming charge of mercury fulminate, lead azide, or other initiator.

**32. Mercury fulminate.**—*a. General.*—Mercury fulminate is a heavy crystalline solid, white when pure but ordinarily a faint brownish yellow or grayish tint. It is extremely sensitive to heat, friction, spark, flame, or shock, detonating completely in nearly every instance. Its sensitivity varies with temperature.

*b. Use.*—Mercury fulminate is used only for the purpose of bringing about the detonation of the less sensitive high explosives or the ignition of propellant explosives. It may be used alone or mixed with potassium chlorate.

**33. Lead azide.**—Lead azide is an initiating compound used for bringing about detonation of high explosives. It is a fine cream-colored compound. It is sensitive to flame but is too insensitive to be used alone where initiation is by impact of a firing pin. It is not easily decomposed by heat. It flashes at a much higher temperature than mercury fulminate. Less weight of lead azide than of mercury fulminate is required to detonate an equal amount of TNT, tetryl, etc. Lead azide has been introduced to supersede mercury fulminate.

**34. Miscellaneous explosives.**—*a. Trimonite.*—Trimonite is a mixture of picric acid and mononitronaphthalene. It may be used as a substitute for TNT in shell wherever amatol may also be used as a substitute.

*b. Ammonal.*—Ammonal is a high-explosive filler for shell. It is composed of TNT, ammonium nitrate, and flaked aluminum. The term ammonal refers generally to explosive mixtures containing TNT and powdered aluminum. As a rule, ammonal explosives are insensitive and, because of the aluminum content, detonate with resultant higher temperature and brighter flash than other high explosives. They are used in proving ground tests for better observation.

## SECTION V

## CHEMICAL AGENTS

	Paragraph
General .....	35
Classification .....	36
Painting and marking .....	37
Description .....	38
Decontamination .....	39

**35. General.**—*a. Definition.*—A chemical agent is a substance which, by its ordinary and direct chemical action and in concentrations attainable in the field, produces a toxic or an irritating (harassing) physiological effect, a screening smoke, an incendiary action, or any combination of these. An agent that produces more than one of these effects is classed according to its principal use.

*b. Gas mask and protective clothing.*—The service gas mask will give full protection against war gases in concentrations likely to be encountered in the field. It will not protect against carbon monoxide, illuminating gas, ammonia, or cyanide gas. It is therefore not suitable for use in case of industrial accidents or fires. For special operations in extremely heavy concentrations, protective clothing may be necessary. For operations where vesicant gases are present, protective clothing should be worn.

*c. References.*—There is included in this section only a general treatment of the character and uses of chemical agents, the protection required, first-aid treatment, and decontamination measures. Further information will be found in TM 3-215, TM 9-850, FM 21-10, and FM 21-40.

**36. Classification.**—Chemical agents are classified according to—

*a. Tactical use.*—(1) *Casualty agents.*—Used directly against enemy personnel to produce casualties.

(2) *Harassing agents (irritants).*—Used to reduce military efficiency by forcing enemy personnel to mask.

(3) *Screening agents.*—Used to produce an obscuring smoke or fog.

(4) *Incendiary agents.*—Used to cause the ignition of combustible materials.

(5) *Simulated agents.*—Used for testing equipment or training personnel. They are harmless substances whose physical properties are similar to those of the agent represented.

*b. Physiological effect.*—(1) (a) *Lung irritants.*—Incapacitate by damaging lung or bronchial tissue.

(b) *Vesicants.*—Cause inflammation, burns, and destruction of tissue both internally and externally.

(c) *Lacrimators (tear producers)*.—Cause a copious flow of tears and intense, though temporary, irritation of the eyes.

(d) *Sternutators (irritant smokes)*.—Cause violent headache, nausea, and sneezing, and temporary physical debility.

(2) Any of the above physiological effects may be incidentally produced by an agent having some other primary classification such as incendiary or screening smoke.

c. *Purpose*.—(1) *Gas*.—An agent which produces either a toxic or irritating physiological effect. Such an agent may be in solid, liquid, or gaseous state before dispersion. Gases are further classified as persistent—those remaining effective at the point of release for more than 10 minutes; and nonpersistent—those which become ineffective within 10 minutes.

(2) *Smoke*.—An agent which produces an obscuring screen.

(3) *Incendiary*.—An agent which produces heat sufficient to ignite combustible materials.

37. **Painting and marking**.—a. *Painting*.—In general, ammunition is painted to prevent rust and to provide, by means of the color, a ready means of identification as to type. Chemical ammunition is identified by the base color, gray.

b. *Marking*.—The particular agent used as chemical filler is indicated in the marking on the ammunition by one or two bands and the type of filler and its symbol, all in a distinctive color in accordance with the table in paragraph 38.

38. **Description**.—a. *General*.—The type, common name, and symbol of the principal chemical agents are included in the table below.

b. *Vesicant gases*.—The principal persistent casualty agents are mustard gas and lewisite.

(1) Mustard gas (HS) is a dark brown liquid which slowly evaporates to a colorless gas having the odor of garlic. Its principal physiological effect is that of a vesicant although the blistering does not ordinarily appear for several hours. If inhaled, the vapors have a lung-irritant effect. For complete protection against HS, both gas mask and protective clothing are necessary. First-aid measures consist in washing with copious amounts of soap and water or wiping off with organic solvents such as solvent, dry-cleaning, and neutralizing with a thin paste of chloride of lime. Clothing contaminated by HS should be removed at once and decontaminated by airing or steaming. The tactical use of HS is to neutralize areas, contaminate matériel, cause casualties, and harass enemy personnel. It is projected by artillery and mortar in shell, from airplanes by bombs and sprays, and left by retreating troops in land mines. HS renders food and water unfit for use.

(2) Lewisite (M1) is a dark brown liquid evaporating to a colorless gas which has the odor of geraniums. In addition to being vesicant and lung-irritant, lewisite is an arsenical poison. Gas mask and protective clothing are necessary for protection against M1. First-aid measures consist of washing with soap and water, or a 5-percent solution of sodium hydroxide followed by alcohol. Tactical use of M1 and methods of projection are the same as those for HS. It renders food and water permanently unfit for use.

*c. Nonpersistent gases.*—The principal nonpersistent casualty agents are chlorine, phosgene, and chlorpicrin.

*Typical chemical agents*

Type	Tactical use	Common name	Symbol	Marking
Persistent gas	Casualty ---	Mustard gas ----- Lewisite -----	HS M1	XX* GAS and 2 bands (all in green).
Nonpersistent gas.	Casualty ---	Chlorine ----- Phosgene ----- Chlorpicrin -----	Cl CG PS	XX* GAS and 1 band (all in green).
Irritant gas ---	Harassing ---	Tear gas ----- Tear gas solution --- Tear gas-chlorpicrin. Adamsite ----- Snceze gas -----	CN CNB CNS CM DA	XX* GAS and 1 band (all in red).
Smoke -----	Screening ---	HC-Smoke ----- FS-Smoke ----- FM-Smoke ----- White phosphorus	HC FS FM WP	XX* SMOKE and 1 band (all in yellow).
Incendiary ---	Incendiary ---	Thermit ----- Barium mixture --- Thermate -----	TH F8	XX* INCENDIARY and 1 band (all in purple).
Simulated agents.	Training ---	Asbestine suspension. Molasses residuum	AS MR	Symbol of agent; type band, and color of agent represented.

\*Symbol of the filler such as CN, WP, HS, etc.

(1) Chlorine (Cl) is a greenish-yellow gas with a pungent odor. Its physiological action is that of lung irritant. For protection the service gas mask is sufficient. First aid consists in removing the casualty to pure air, keeping him warm and quiet, giving mild non-alcoholic stimulants such as coffee or tea, and evacuating as an absolute litter case. Tactical use is as a casualty agent. It is used alone, and with others of this group, in gas cloud attack from cylinders and Livens projector shell. It has a vigorous corrosive action on wet or

moist metals. Food and water contaminated with Cl can be made fit for use under the direction of a medical officer.

(2) Phosgene (CG) appears on projection as a whitish cloud changing to colorless gas. It has the odor of silage or new-mown hay. Physiological action, protection required, first aid, tactical use, action on metals, and action on food and water are the same as for Cl.

(3) Chlorpicrin (PS) is an oily liquid changing slowly in the open to a colorless gas with the odor of flypaper. Physiological action is irritation of eyes, nose, and throat, and, as concentration increases, PS causes nausea and lung irritation. Gas mask is required for protection. First aid is the same as for Cl, for exposure to the vapor. In addition, any splashes of liquid agent on the skin should be washed off, preferably with an alcoholic solution of sodium sulfite. Tactically, it is used in heavy concentrations as a casualty agent and in lighter concentrations as a harassing agent. PS is used with tear gas in artillery and mortar shell, airplane bombs and sprays, with phosgene and chlorine in Livens projector shell, and from cylinders. It has slight action on metals. Contaminated food and water may be rendered fit for use under the direction of a medical officer.

*d. Irritant gases.*—The harassing agents (irritants) are the lacrimators and the irritant smokes.

(1) Chloracetophenone (CN), commonly known as tear gas, is typical of the lacrimators. It is a solid with a faint fragrant odor which resembles that of apple or locust blossoms. Its physiological action is extreme irritation of the eyes. A gas mask is sufficient for protection. First-aid treatment other than removal to pure air is rarely necessary but in aggravated cases washing out the eyes with boric acid solution will help. CN is used alone in grenades and mortar shell. It is used in solution alone (CNB) and with chlorpicrin (CNS) in artillery and mortar shell, and from airplanes in bombs and sprays. CN has slight action on metals. It imparts only a disagreeable taste to food and water.

(2) The irritant smokes are typified by adamsite (DM). DM is a solid which is dispersed by burning type munitions and appears as a yellow smoke with an odor somewhat resembling coal smoke. Its physiological action is to cause lacrimation, violent sneezing, intense headache, nausea, and temporary physical debility. For protection, the service gas mask, which is equipped with an efficient smoke filter, is required. Treatment other than removal to pure air is seldom necessary although breathing light concentrations of chlorine, as from a bleaching powder bottle, will give relief. Tactical use is as a harassing agent and it can only be used from burning type munitions

such as candles and grenades. DM has slight action on metal but renders food and water permanently unfit for use.

*e. Screening smokes.*—These are produced by the dispersion of particles in the atmosphere by the burning of solids and by spraying liquids. They are used to screen movements and activity, to blanket the enemy and thus obtain fire superiority, to inactivate observers, to spot artillery fire and bombing, and to disguise cloud gas.

(1) Sulfur trioxide-chlorosulfonic acid mixture (FS) is a liquid which when dispersed into a humid atmosphere produces a dense white smoke. It is projected in shell, by airplane spray, and from portable cylinders. FS liquid is very corrosive and rubber gloves should be worn in handling it. No mask is necessary for the smoke. First aid for FS liquid burns consists of washing with large amounts of water, then with bicarbonate of soda solution, and then treating as for ordinary burns. The smoke is harmless to personnel except in very heavy concentrations. Liquid FS renders food and water unfit for use; the smoke merely imparts an unpleasant taste. On account of its corrosive nature, certain restrictions are in force on the use of FS. (See AR 750-10.)

(2) Titanium tetrachloride (FM) is similar to FS in appearance, properties, and use.

(3) Hexachlorethane-zinc mixture (HC) can be used only from burning type ammunition such as grenades and candles. No protection of personnel or matériel is required. Food and water are not spoiled but acquire a disagreeable odor.

(4) White phosphorus (WP) is a yellow waxy substance which takes fire spontaneously and produces a dense white smoke. Its principal use is to produce smoke although it is an incendiary and casualty agent as well. WP is used only in explosive type projectiles, artillery and mortar shell, and airplane bombs. When the projectile explodes it scatters small pieces of phosphorus which ignite spontaneously. These particles continue to burn even when embedded in the flesh. Phosphorus burns should be kept under water or well packed with moist earth until the particles are removed. Phosphorus smoke is uncomfortable to breathe but harmless; however, the particles will poison food and water.

*f. Incendiaries.*—Various types of incendiary agents are used. An aluminum-barium nitrate mixture (F8), thermite, or thermate are used in magnesium or steel containers. Thermate, a mixture of thermite with other substances which accelerate the burning, is used in incendiary bombs and grenades. Combustible oils have been used, sometimes with particles of metallic sodium, which re-ignite the



oil when water is used to quench the fire. Phosphorus is used, especially against light and inflammable construction. Gasoline and mixtures of gasoline with rubber, alcohol and other substances is used in bombs and grenades. Gasoline-filled bombs have a black powder burster and igniter. The gasoline-filled grenades are glass bottles provided with a pull-wire fuze lighter or other type of igniting fuze.

**39. Decontamination.**—*a.* Ammunition should be kept in sealed containers. If exposed to mustard gas, however, it must be thoroughly decontaminated before it can be fired. Contaminated ammunition will be cleaned with agent, decontaminating, noncorrosive, or if this is not available, strong soap and cool water. Corroded ammunition will either be cleaned thoroughly or discarded. Agent, decontaminating (chloride of lime), which is used in decontaminating other matériel, will never be used on or near ammunition supplies, particularly in its dry powdered form, as flaming occurs through the use of chloride of lime on mustard. Matériel other than ammunition will be decontaminated according to instructions in TM 9-850, FM 21-40, or TC 38, 1941.

*b.* The vesicant properties of lewisite can be destroyed through use of the same procedure used for mustard. The products resulting from such decontamination, when washed on the ground, are extremely poisonous because of their arsenic content and will permanently poison drinking water in the vicinity of the contaminated area.

*c.* Smokes and nonpersistent gases are corrosive to metal, especially in the presence of moisture. The agent must be removed or neutralized to prevent damage to the equipment. Metallic matériel exposed to any of these agents should be cleaned of old oil with a solvent such as gasoline, washed with a solution of sodium carbonate or other alkali, and reoiled. Fabrics and leather exposed to FS must be immediately washed as prescribed in paragraph 13, AR 750-10.

## CHAPTER 2

### BASIC TYPES OF AMMUNITION

	Paragraphs
SECTION I. Small-arms ammunition.....	40-57
II. Grenades .....	58-64
III. Antitank mines .....	65-70
IV. Mortar ammunition.....	71-75
V. Artillery ammunition.....	76-87
VI. Bombs.....	88-98
VII. Pyrotechnics .....	99-110

#### SECTION I

#### SMALL-ARMS AMMUNITION

	Paragraph
General .....	40
Cartridges.....	41
Types.....	42
Ball.....	43
Armor-piercing.....	44
Tracer and incendiary.....	45
Blank.....	46
Gallery practice.....	47
Guard.....	48
Subcaliber.....	49
High-pressure test.....	50
National Match.....	51
Dummy.....	52
Shotgun shells.....	53
Grades.....	54
Care and precautions in handling.....	55
Precautions in firing.....	56
Packing and marking.....	57

**40. General.**—*a.* The information in this section is limited to a general description of the several types of small-arms ammunition used for military purposes. Many types are manufactured to the same profile, consequently cartridges of the same caliber although of different model may be very similar in appearance. Each type has a characteristic marking which is described in this section. Different models of the same type may be identified by the marking on the packing boxes and cartons. A detailed description of each type and model, including characteristics, means of identification.

care and handling, packing, and marking will be found in TM 9-1990.

*b. Small-arms ammunition* comprises the ammunition used in small-arm weapons—rifles, pistols, revolvers, and machine guns in calibers .22, .30, .45, and .50, and shotguns of 12-gage.

41. *Cartridges.*—*a. General.*—A round of small-arms ammunition is known as a cartridge. In general, it consists of a bullet, a propelling charge, a primer, and a cartridge case, made into a unit assembly. Figure 5 shows a typical cartridge in section with the various parts named.

*b. Bullet.*—Bullets for service use have a metal core which is covered with a gilding metal jacket. A cannelure is generally rolled or cut into the jacket to provide a recess into which the cartridge case is crimped.

*c. Propelling charge.*—There are two types of small-arms propellants generally used, the single-base nitrocellulose type and the double-base type. The double-base type is a mixture of nitrocellulose and nitroglycerin which burns more rapidly than the single-base type. The weight of the charge and granulation of the powder is in accordance with specification requirements for velocity and pressure. The charge is assembled loosely in the cartridge case.

*d. Primer.*—The primer consists of a brass or gilding metal cup which contains a primer composition pellet of sensitive explosive, a paper disk, and a brass anvil.

*e. Cartridge case.*—The cartridge case is of drawn brass. It serves as a means whereby the other components, the primer, the propelling charge and the bullet, are assembled into a unit, the cartridge. Another of its functions is to seal the chamber against the escape of gases to the rear when the cartridge is fired. This action is known as obturation. To make the cartridge waterproof, the primer is sealed in the primer seat and the bullet is sealed in the neck of the cartridge case by a thin film of lacquer or varnish at the time of manufacture.

42. *Types.*—Small-arms cartridges are classified according to type as follows:

*a. Ball.*

*b. Armor-piercing.*

*c. Tracer.*

*d. Incendiary.*

*e. Blank.*

*f. Gallery practice.*

(1) Caliber .22 (present standard).

(2) Caliber .30 (now used for guard purposes only).

*g. Guard.*

- h. Subcaliber.
- i. High-pressure test.
- j. National Match.
- k. Dummy.
- l. Shotgun shells.

**43. Ball.**—This type of cartridge, intended for use against personnel and light matériel targets, is the most widely used of the service types. The term “ball,” although no longer accurately describing the shape of the modern bullet, has been continued in use to designate that type of bullet and ammunition used for the same purposes as ammunition of very early design, the bullet of which was actually a ball. Typical ball cartridges of different calibers are shown in figure 4.

**44. Armor-piercing.**—This type of cartridge, intended for use against armored aircraft, armored vehicles, concrete shelters, and similar bullet-resisting targets, is characterized by the bullet, which has an armor-piercing core. It is distinguished from other types of ammunition by the nose of the bullet, which is painted black. A typical armor-piercing cartridge is shown in figure 6.

**45. Tracer and incendiary.**—*a. Tracer.*—This type of cartridge is intended for use with other types to show the gunner, by its trace, the path of the bullets. It is also used for incendiary purposes. The nose of the bullet is painted red to correspond to the color of the trace to distinguish it from other types. Figures 8 and 9 show typical rounds of tracer ammunition.

*b. Incendiary.*—This ammunition in calibers .30 and .50 resembles the ball or armor-piercing ammunition in outward appearance. It may be identified by the light blue paint on the tip of the bullet.

**46. Blank.**—This type of cartridge is distinguished by the absence of bullets. It is used for simulated fire, training cavalry mounts, signaling, and firing salutes; also in machine guns equipped with blank firing attachments, in order to operate these weapons for instructional purposes. For precautions in firing blank ammunition, see TM 9-1990. Although other blank cartridges may be found in service, only those authorized in TM 9-1990 will be fired. Typical blank cartridges are shown in figures 7 and 10.

**47. Gallery practice.**—*a.* The present standard ammunition for gallery practice is the cartridge, ball, caliber .22, long rifle (fig. 4)—a rim fire cartridge of commercial manufacture.

*b.* The former standard gallery-practice ammunition, cartridge, gallery practice, caliber .30, M1919, is now reserved for guard purposes. It is shown in figure 4.

**48. Guard.**—This type of cartridge, the bullet of which has a much lower velocity than that of service ammunition, is provided for

guard purposes. The cartridge, guard, caliber .30, M1906, as currently issued is identified by six short corrugations just below the shoulder of the cartridge case. It is no longer standard. Therefore when stocks are exhausted, this model will be superseded by the cartridge, guard, caliber .30, M1.

**49. Subcaliber.**—This type of cartridge is designed for use in conjunction with subcaliber tubes in cannon for training personnel in conduct of fire. It is identified by the extracting rim on the head of the case instead of the usual groove.

**50. High-pressure test.**—This type of cartridge is manufactured for use in the proof firing of small-arms weapons. Since the propelling charge of this ammunition is designed to develop excessive pressure, these cartridges should never be used for any other purpose, and when used for the purpose intended, all personnel should be protected by adequate cover. This ammunition is distinguished from other types by the tin coating of the cartridge case. In some models the word "TEST" is stamped on the heads of the cartridge cases.

**51. National Match.**—These are manufactured each year for the National Matches of that year. The following year they may be used in preliminary firing for such matches. The second year, and thereafter, they are considered standard service ammunition. National Match ammunition is packed in blue boxes in contrast to the usual brown and the head of each cartridge is stamped "N. M." and with the year of manufacture.

**52. Dummy.**—Dummy cartridges are provided for training and practice in loading and in simulated fire. Such ammunition is inert. For identification, the cartridge case is tinned and the primer omitted. Earlier designs containing an inert primer are identified by holes in the body of the cartridge case.

**53. Shotgun shells.**—Shotgun shells (shot shells) of appropriate loads in 12-gage are provided for the following purposes:

- a. For guard and combat use.
- b. For trapshooting.
- c. For hunting.

**54. Grades.**—Current grades of existing lots of small-arms ammunition are established by the Chief of Ordnance and are published in OFSB 3-5. No lots other than those of current grade appropriate for the weapon will be fired. Grade 3 indicates unserviceable ammunition which will not be fired.

**55. Care and precautions in handling.**—*a.* Small-arms ammunition is comparatively safe to handle. However, care must be taken to prevent ammunition boxes from becoming broken or damaged. All broken boxes will be immediately repaired and careful attention

given to the transfer of all markings to the new parts of the box. The metal liners should be air tested and sealed if equipment for the work is available.

*b.* Ammunition boxes should not be opened until the ammunition is required for use. Ammunition removed from airtight containers, particularly in damp climates, is apt to corrode, thereby causing it to become unserviceable.

*c.* When cartridges are taken from their original packings for loading into clips or machine-gun belts, the clips or belts should be so tagged or marked as to preserve the ammunition lot number, thereby preventing the ammunition from falling into grade 3 through loss of lot number.

*d.* Ammunition should be carefully protected from mud, sand, dirt, and water. If it gets wet or dirty, it should be wiped off at once. Should light corrosion or verdigris form on cartridges, it should be wiped off. However, cartridges should not be polished to make them look brighter or better.

*e.* The use of oil or grease on cartridges is dangerous and is prohibited.

*f.* Cartridges that are dented, those that have loose bullets, and those otherwise defective should not be fired.

*g.* For further information, see sections I and VI and TM 9-1990.

**56. Precautions in firing.**—*a.* Because a misfire cannot immediately be distinguished from a hangfire, it is unsafe to open the bolt of a rifle immediately when a misfire occurs. When the rifle M1, caliber .30, fails to fire, it should be recocked by operating the trigger guard and refired before opening the bolt.

*b.* For other rifles, in the event of misfire, the rifle should be recocked by drawing back the cocking piece and refired before opening the bolt.

*c.* Before firing, the firer should be sure that the bore of the weapon is free of any foreign matter such as cleaning patches, mud, sand, snow, and the like. To fire a weapon with any obstruction in the bore will damage the weapon and may result in injury to the firer.

*d.* Ammunition should not be exposed to the direct rays of the sun for any considerable length of time. This is likely to affect its firing qualities seriously.

*e.* No small-arms ammunition will be fired until it has been identified positively by ammunition lot number and grade as published in the latest revision of OFSB 3-5.

*f.* Any serious malfunction of ammunition must be reported promptly to the ordnance officer under whose supervision the mate-

rial is maintained and issued. The ordnance officer will report such malfunction to the Chief of Ordnance as provided in AR 45-30. It is important, therefore, that all evidence be preserved. This includes the cartridge case, the other cartridges from the same box, the weapon concerned, all recoverable pieces—in short, everything that might throw light on the cause of the malfunction.

57. **Packing and marking.**—Detailed packing and marking regulations are given in TM 9-1990. The following table shows the method of packing and the identifying color band on the packing boxes for the various types of small-arms ammunition. Typical packing boxes are shown in figure 11.

Type	Primary band <sup>1</sup>	Superimposed band <sup>1</sup>	Packing
Ball, cal. .30	Red	None	Cartons, 5- and 8-round clips in cartons or bandoleers, web or link belts.
Ball, cal. .45	Red	None	Cartons.
Ball, cal. .50	Red	None	Cartons, link belts.
Blank, cal. .30	Blue	None	Cartons.
Blank, cal. .45	Blue	None	Cartons.
Dummy, cal. .30	Green	None	Cartons, 5-round clips in cartons.
Dummy, cal. .45	Green	None	Cartons.
Dummy, cal. .50	Green	None	Cartons.
Guard, cal. .30	Orange	None	Cartons, 5-round clips in cartons.
Armor-piercing, cal. .30.	Yellow	Blue	Cartons.
Armor-piercing, cal. .50.	Yellow	Blue	Cartons.
Tracer, cal. .30	Yellow	Green	Cartons.
Tracer, cal. .45	Yellow	Green	Cartons.
Tracer, cal. .50	Yellow	Green	Cartons.
Gallery practice, cal. .30.	Brown	None	Cartons.
Cartridge, carbine, cal. .30, M1.	Red	None	Cartons.
Subcaliber, cal. .30	None	None	Cartons.
High - pressure test, cal. .30.	Yellow	None	Cartons.
High - pressure test, cal. .45.	Yellow	None	Cartons.
High - pressure test, cal. .50.	Yellow	None	Cartons.
Blank, cal. .50	Blue	None	Cartons.
Ball and tracer, cal. .30.	Yellow, red, green (3-stripe band).		Link belts

## AMMUNITION, GENERAL

Type	Primary band <sup>1</sup>	Superimposed band <sup>1</sup>	Packing
Ball and tracer, cal. .50.	Yellow, red, green (3-stripe band).	-----	Link belts.
Incendiary, cal. .30	Yellow-----	Red-----	Cartons.
Incendiary, cal. .50	Yellow-----	Red-----	Cartons.
Cartridge, rifle, grenade, cal. .30, M3.	Two blue bands separated by band width.	None-----	

<sup>1</sup> Bands on the face of boxes for caliber .30 and caliber .45 ammunition are vertical; bands on the ends are horizontal. Bands on boxes for caliber .50 ammunition are diagonal on all sides. Markings on caliber .50 boxes include color oblongs.



AMMUNITION, GENERAL

- A — CARTRIDGE, BALL, CAL. .22, LONG RIFLE
- B — CARTRIDGE, BALL, CAL. .45, M1911
- C — CARTRIDGE, CARBINE, CAL. .30, M1
- D — CARTRIDGE, BALL, CAL. .50, M2
- E — CARTRIDGE, BALL, CAL. .30, M2
- F — CARTRIDGE, GUARD, CAL. .30, M1

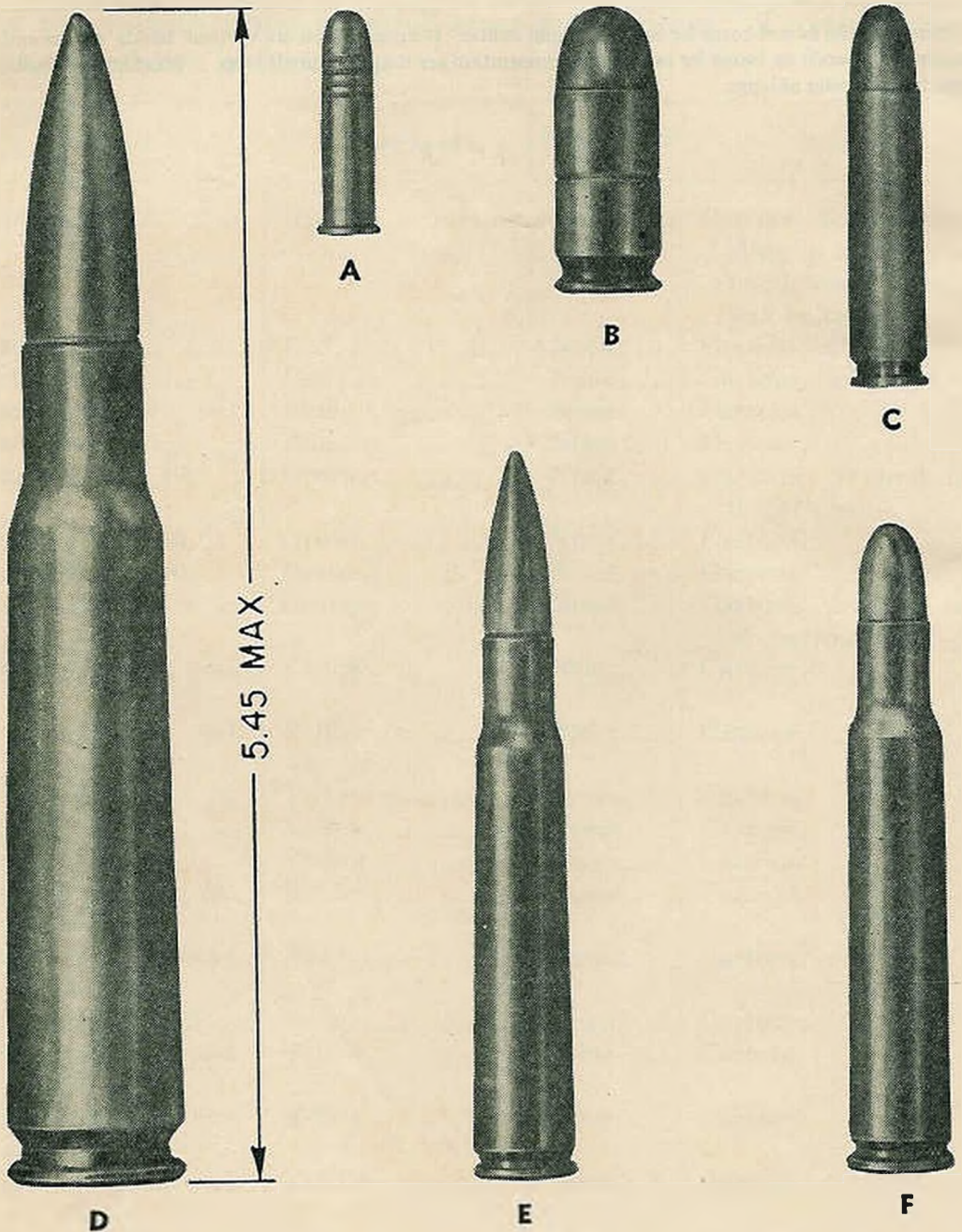

FIGURE 4.—Typical ball cartridges.

RA PD 4040A

AMMUNITION, GENERAL

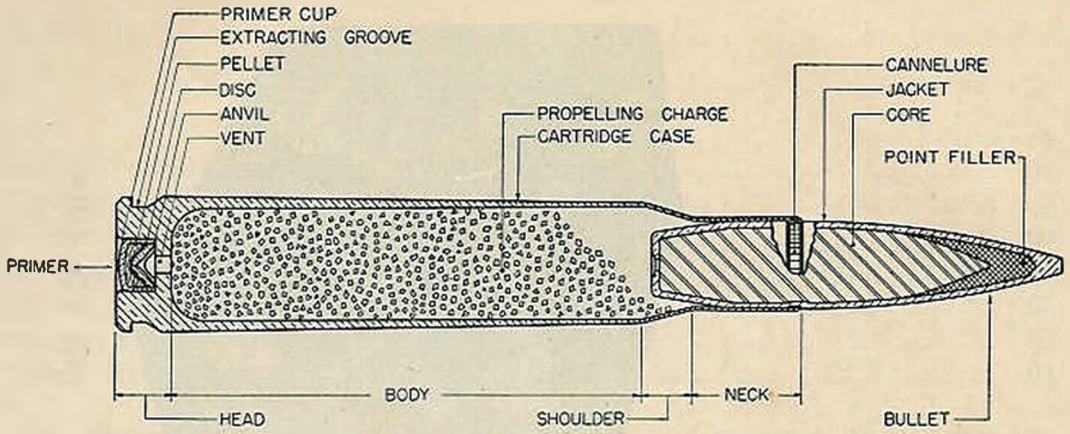

FIGURE 5.—Section of ball cartridge, caliber .50.

RA PD 4033

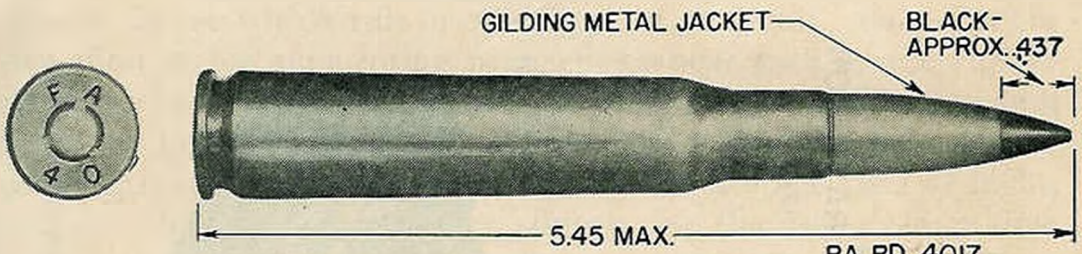

FIGURE 6.—Cartridge, armor-piercing, caliber .50.

RA PD 4017

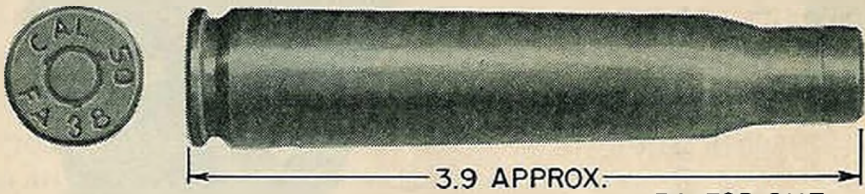

FIGURE 7.—Cartridge, blank, caliber .50.

RA FSD 2113



FIGURE 8.—Cartridge, tracer, caliber .50.

RA FSD 2112A

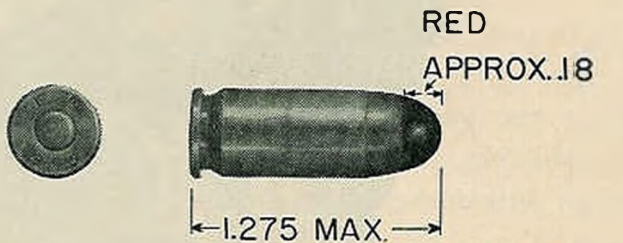
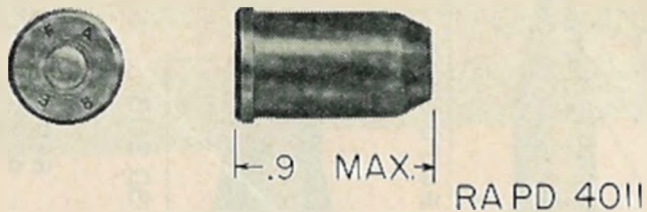

FIGURE 9.—Cartridge, tracer, caliber .45.

RA PD 4019



RAPD 4011

FIGURE 10.—Cartridge, blank, caliber .45.



RA PD 4014

FIGURE 11.—Small-arms ammunition packing boxes.

## SECTION II

## GRENADES

	Paragraph
Description and classification-----	58
Fragmentation and offensive grenades-----	59
Chemical grenades-----	60
Rifle grenades-----	61
Training grenades-----	62
Care and precautions in handling-----	63
Packing and marking-----	64

**58. Description and classification.**—*a. General.*—Grenades are explosive or chemical missiles, intended for use at relatively short range. Although usually designed to be thrown by hand, they may be made for use with a rifle or other type of projector. Grenades are very effective for augmenting primary weapons such as the rifle in trench warfare, for dispersing mobs, quelling riots, etc. The grenades thrown by hand are fitted with a delay action fuze, the delay for explosive grenades being slightly more than the average time of flight, 5 seconds; for chemical grenades, slightly less than the average time of flight, 2 seconds.

*b. Types.*—There are two basic types of grenades: those designed to be thrown by hand, and those designed to be projected by rifles or other launchers, generally termed rifle grenades. Hand grenades are classified into four general types: fragmentation grenades, offensive grenades, chemical grenades, and practice or training grenades. Rifle grenades are classified as antitank and practice.

**59. Fragmentation and offensive grenades.**—*a. Fragmentation grenades.*—Fragmentation grenades contain an explosive charge provided to break the body of the grenade and project fragments at high velocity. To assist in the formation of uniform fragments the body is serrated, horizontally and vertically. It is made of cast iron in the shape of a large lemon, approximately 2¼ inches in diameter by 4½ inches long (fig. 12). The standard bursting charge is E. C. firing powder, which is exploded by an igniting fuze. Fuzes for all types of fragmentation and practice grenades are designed to function after 5 seconds' delay.

*b. Offensive grenades.*—Offensive grenades are made of paper or fiber container and a high explosive filler. They are used for demolition of matériel and emplacements. They are equipped with a detonating fuze with 5 seconds' delay. The grenade, hand, offensive, Mk. IIIA1, representative of this type, contains approximately ½ pound of pressed TNT.

**60. Chemical grenades.**—Chemical grenades contain a "burning

mixture" which, when ignited by its fuze, produces an irritant gas or an obscuring smoke. These are known as gas grenades or smoke grenades. The body of the chemical grenade is a short cylinder approximately  $2\frac{1}{2}$  inches in diameter by  $5\frac{1}{2}$  inches long (fig. 12). Fuzes for chemical grenades are designed to function with 2 seconds' delay.

61. Rifle grenades.—*a.* The present standard rifle grenades are specialized grenades for use against armored targets. They are designated grenade, AT, M9 and M9A1. They have a steel body containing the high explosive and a fuze assembly and a tail assembly, consisting of a hollow tube and a wheel-shaped fin. The fuze functions upon impact. A safety pin located on the body of the grenade must be removed to arm the fuze. The fuze in the grenade, AT, M9, will normally detonate only upon impact with a hard resistant body. The fuze of the M9A1 grenade is more sensitive and will function upon impact with soft earth. These grenades are to be fired only from the rifle, caliber .30, M1903 or M1917. They are projected by use of a launcher which fits on the muzzle of the rifle. A special cartridge, designated cartridge, rifle grenade, M3, must be used for projecting these grenades. The grenades are packed in kits containing 10 grenades, a launcher for either the M1917 or M1903 rifle, sights, and recoil pad. A cartridge is packed with each grenade in a cellophane wrapper in the tube of the grenade.

*b.* The grenade, AT, M10, is similar in shape and function to the grenade for use with the caliber .30 rifle. It is larger and is projected by use of a special projector.

62. Training grenades.—*a.* A grenade of the same size, shape, and weight as the fuzed fragmentation grenade, but inert, is provided for training in throwing. The grenade formerly used for such purposes was made of cast iron and was known as grenade, hand, dummy, Mk. I. This design has recently been modified by adding a pull ring and safety pin (cotter pin), thereby more closely simulating the fragmentation grenade. This modified grenade is known as grenade, hand, training, Mk. IA1, and is shown in figure 12.

*b.* A practice grenade, known as grenade, hand, practice, Mk. II, with hand grenade igniting fuze M10A1, was formerly standard for practice purposes. It contains a small charge of black powder and a live fuze, and is painted blue to distinguish it from the training grenade.

*c.* The practice grenades designated grenade, AT, practice, M11 and M13, are of the same size and appearance as the explosive types M9A1 and M10 respectively. They are provided for training and practice in aiming and firing. These grenades are inert and may be fired a

AMMUNITION, GENERAL

- A—GRENADE, HAND, FRAGMENTATION, MKII
- B—GRENADE, HAND, TRAINING, MKIAI
- C—GRENADE, RIFLE, H.E., M9
- D—GRENADE, RIFLE, PRACTICE, M11
- E—GRENADE, HAND, OFFENSIVE, MKIII
- F—GRENADE, HAND, GAS, IRRITANT, CN-DM, M6
- G—GRENADE, HAND, GAS, IRRITANT, CN, M7
- H—GRENADE, HAND, SMOKE, HC, M8

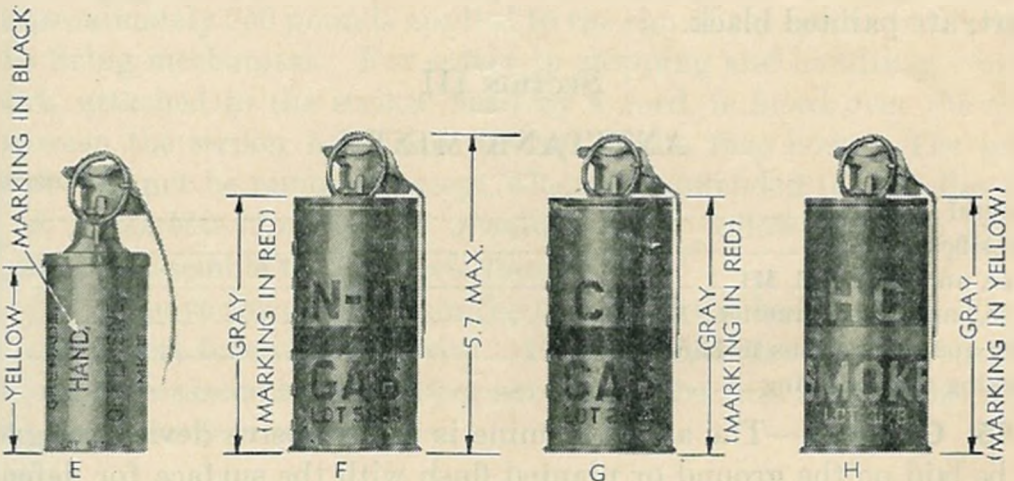
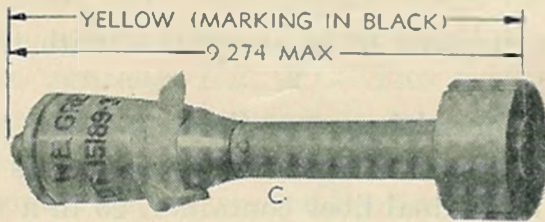
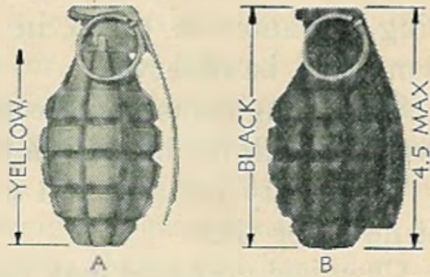

RA PD 4318A

FIGURE 12.—Typical grenades.

number of times if they are not damaged. Replacement fin assemblies and extra cartridges are provided separately. The cartridge used for launching is the same as that used for the corresponding explosive type.

**63. Care and precautions in handling.**—*a. Care.*—Information concerning the care to be exercised in handling grenades will be found in chapters 1 and 3 of this manual and in FM 23-30.

*b. Precautions.*—In addition to the general safety precautions in handling ammunition given in sections I and VI, chapter 3, the following will be observed:

(1) Since fragments may be projected over 200 yards, fragmentation grenades will not be used in training without adequate cover.

(2) The safety (cotter) pin will be removed just before throwing and at no other time.

(3) Chemical grenades may occasionally flash, hence, when used in maneuvers, they will be so thrown as to function not less than 20 feet from personnel.

(4) Duds will be disposed of in accordance with the provisions in chapter 4.

**64. Packing and marking.**—*a. Packing.*—The present practice is to pack fragmentation and chemical grenades, as fuzed complete rounds, each in an individual fiber container, 25 in a wooden packing box. Some packings on hand, packed under older standards, contain 10 grenades to the metal-lined box. Others contain unfuzed grenades, 25 per box.

*b. Marking.*—Fragmentation grenades and those containing high explosives are painted yellow. Chemical-filled grenades are painted gray with band and symbol of filler stenciled on the side. (See table in par. 38.) Practice grenades are painted blue. Training grenades, inert, are painted black.

### SECTION III

#### ANTITANK MINES

	Paragraph
General .....	65
Classification .....	66
Mine, antitank, HE, M1 .....	67
Mine, antitank, practice, M1 .....	68
Care and precautions in handling .....	69
Packing and marking .....	70

**65. General.**—The antitank mine is an explosive device designed to be laid on the ground or planted flush with the surface for defense against armored cars and tanks.

**66. Classification.**—At the present time there is one model each of service and practice antitank mines, the mine, antitank, HE, M1, and the mine, antitank, practice, M1, figures 13 and 14, respectively.

**67. Mine, antitank, HE, M1.**—*a. General.*—This mine with principal data and markings is shown as a complete round assembly in

figure 13. The complete round consists of two components, the loaded mine body and the fuze. The disassembled components are shown in figure 15. A separable part of the body which fits over the fuze to increase the effective size of its head is known as the spider.

*b. Description.*—The steel body is cylindrical, approximately  $2\frac{3}{4}$  inches high and  $7\frac{1}{2}$  inches in diameter. The flanged rim around the top is notched in two places for assembling the spider. In the center of the top is the fuze cavity, approximately 2 inches in diameter and  $2\frac{5}{16}$  inches deep. A carrying ring is attached to the side of the mine. The complete round, mine and fuze, weighs approximately 10.4 pounds; the high explosive filler, 6 pounds. The spider consists of a ring and two cross members with a hook on each end, riveted together as shown in figure 15. These hooks engage the flange on the mine body and the center of the spider rests on the striker head of the fuze.

*c. Fuze, mine, antitank, HE, M1.*—This fuze (fig. 15), which contains the booster as an integral part, is used only in the high explosive mine. It consists essentially of a striker assembly and a body which contains the primer, detonator, and booster. The striker assembly, on the outer end of which is a 2-inch diameter head, protrudes approximately  $\frac{3}{8}$  inch beyond the body of the fuze. The firing mechanism, contained within the striker assembly, is restrained from firing when in the armed condition (safety fork withdrawn) by the collar just below the head and two shear pins. A force of approximately 500 pounds on the striker head is required to actuate the firing mechanism. When assembled to the mine with the spider in place, a force of approximately 250 pounds applied to the rim of the spider will actuate the firing mechanism. For safety in shipping and handling, a safety fork, attached to the striker head by a cord, is fitted over the collar between the striker head and the top of the fuze body. The safety fork will not be removed except when it is intended to arm the fuze.

*d. Assembly (fuzing and arming).*—The following steps are required to assemble the complete round:

(1) Remove the spider from the bottom of the body.

(2) Insert fuze in fuze cavity. Push the fuze down until it latches. When thus assembled the upper surface of the fuze body is flush with the upper surface of the mine.

**NOTE.**—Before inserting fuze, be sure that the fuze cavity is clear—no foreign matter present.

(3) Assemble spider. To assemble the spider, aline, but do not engage, two of the hooks with the two notches in the flange of the body. Engage the other two hooks over the flange on the body. Next press the first two hooks through the notches, then rotate the spider



approximately  $\frac{1}{8}$  turn in either direction to secure the spider to the body.

(4) Plant mine, recording its location.

(5) Withdraw safety fork, thereby arming the fuze. The safety fork should be left beside the mine, attached to its cord—never between the body and spider.

*e. Disassembly (unfuzing and disarming).*—Mines may be disarmed and taken up by reversing the steps in *d* above.

**68. Mine, antitank, practice, M1.**—*a. General.*—This mine with principal data and markings is shown as a complete round assembly in figure 14. The complete round consists of two components, an empty mine body (which includes the spider), and a fuze.

*b. Description.*—These parts are similar in appearance to the corresponding parts of the high explosive mine except that the body has five 1-inch holes equally spaced around the side. There are differences in color and marking which are described in paragraph 70.

(1) Fuze, mine, antitank, practice, M1, is similar in form and operation to the fuze for the high explosive mine described above, except that it contains a smoke-puff charge in place of the booster element.

(2) Fuze, dummy (antitank mine), is completely inert. It is made of metal or plastic to simulate the service fuze and has a removable safety fork.

(3) These fuzes are used with the practice mine body for training and practice.

(4) Differences in painting and marking are described in paragraph 70.

*c. Assembly (fuzing and arming).*—The practice mine is assembled in the same manner as the mine, antitank, HE, M1, described in paragraph 67.

*d. Disassembly unfuzing and disarming.*—See paragraph 67*e*.

**69. Care and precautions in handling.**—In addition to the general provisions of chapters 1 and 3, the following will be observed:

*a. Safety fork.*—The safety fork will not be removed except when it is intended to arm the fuze. The fork is not removed until after the mine has been planted. Should the mine be taken up, the safety fork will first be replaced.

**Caution:** Care will be exercised that no undue load is accidentally brought to bear on the spider, especially the rim, after the safety fork has been removed. A load of approximately 250 pounds on the rim of the spider will actuate the firing mechanism.

*b. Mines laid singly.*—To prevent sympathetic detonation of part or all of a mine field, mines laid singly on the ground should be 3 feet or more apart; if planted flush, 2 feet or more apart.

*c. Mines laid in multiple.*—Should it be required to lay mines in multiple to give a more powerful blast, the mines may be buried one on top of another, or side by side, planted flush, or laid on the surface. If planted flush, adjacent mines should be in contact; if laid on the surface, they may be as much as 18 inches apart. Such planting will insure that all mines in the group will detonate when any one detonates. To prevent sympathetic detonation of part or all of the groups in a mine field, the distances given in *b* above should be correspondingly increased.

**70. Packing and marking.**—*a. Packing.*—Antitank mines are packed in a wooden box which contains five mines and five fuzes (fig. 16). Two data cards are inclosed, one loose and one attached to the inside of the cover so that the instructions are visible. The box is made up with a set of plywood separators and two sets of grooves. As shipped, the fuzes are placed in a fuze container which occupies one compartment of the box; the five mines, with spiders nested to the bottoms, are packed, carrying ring up, one in each of the other five compartments. For convenience in carrying fuzed mines in the field, the same box, but with the partitions moved to the second set of grooves, may be used. The box with five high explosive mines and fuzes weighs approximately 67 pounds. The box with five practice mines and fuzes weighs approximately 62 pounds.

*b. Marking.*—(1) The mine, antitank, HE, M1, is painted yellow with marking in black. The mine, antitank, practice, M1, is painted blue with marking in white. The marking on the head of both types includes—

- (a) Type and model of mine.
- (b) Lot number.
- (c) Manufacturer's initials or symbol.
- (d) Date loaded.

(2) The striker head of the fuze, mine, antitank, HE, M1, is painted yellow, that of the fuze, antitank, practice, M1, red. Both are marked in black on the side with—

- (a) Designation of fuze.
- (b) Loader's lot number.
- (c) Loader's initials.
- (d) Date loaded.

(3) The end cleats of boxes containing practice mines are painted blue and in addition there is a 3-inch blue band around the middle. Boxes for high explosive mines are unpainted. Representative markings on the box are shown in figure 16. For further information see chapters 1 and 3.

TM 9-1900

AMMUNITION, GENERAL

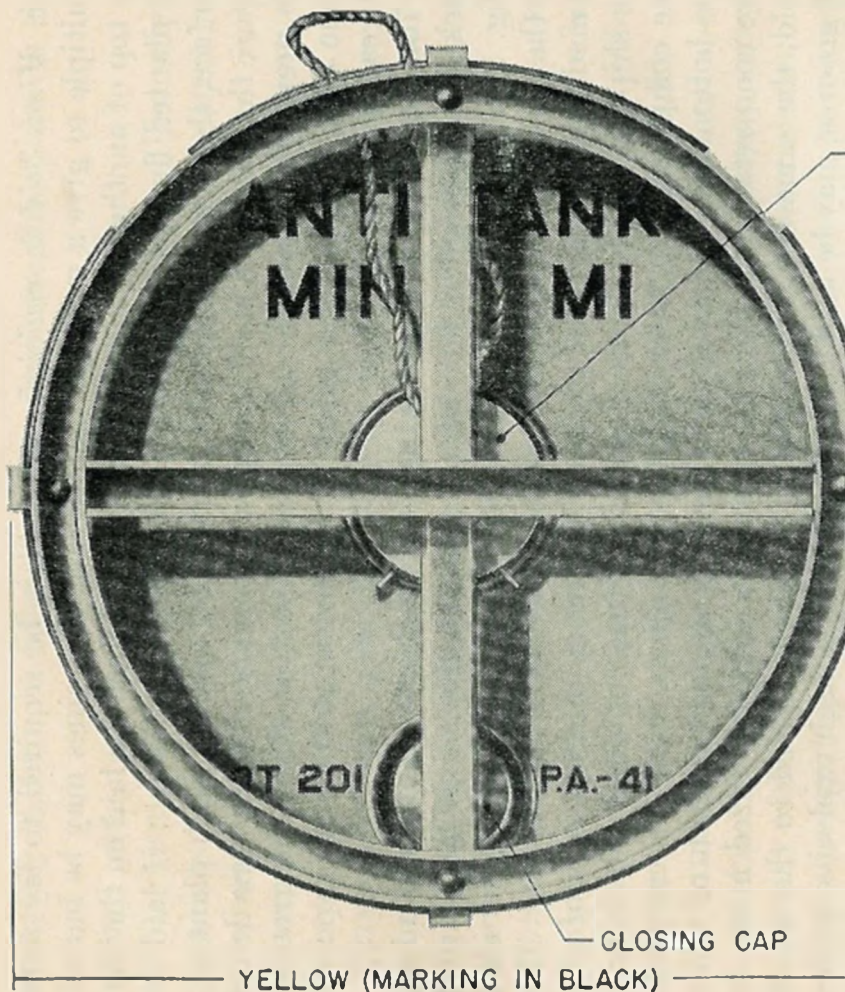

YELLOW (MARKING IN BLACK)

- TOP OF STRIKER-  
YELLOW

SAFETY FORK —  
CADMIUM PLATED

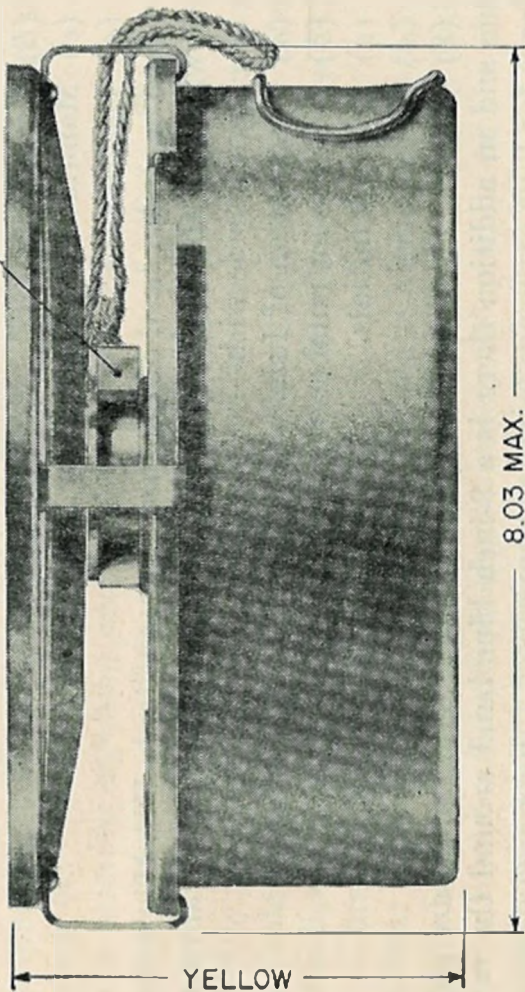

8.03 MAX.

YELLOW

FIGURE 13.—Mine, antitank, high explosive, M1.

RA PD 4036

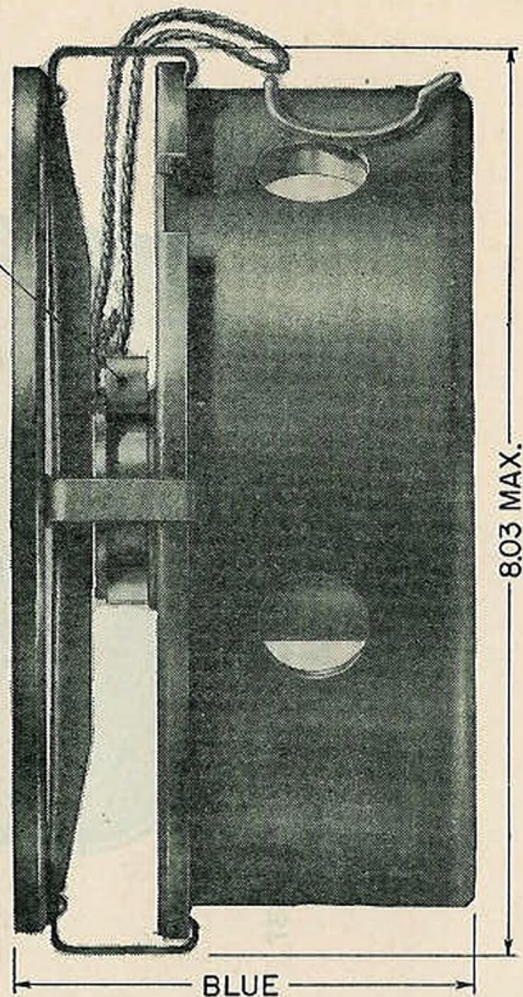
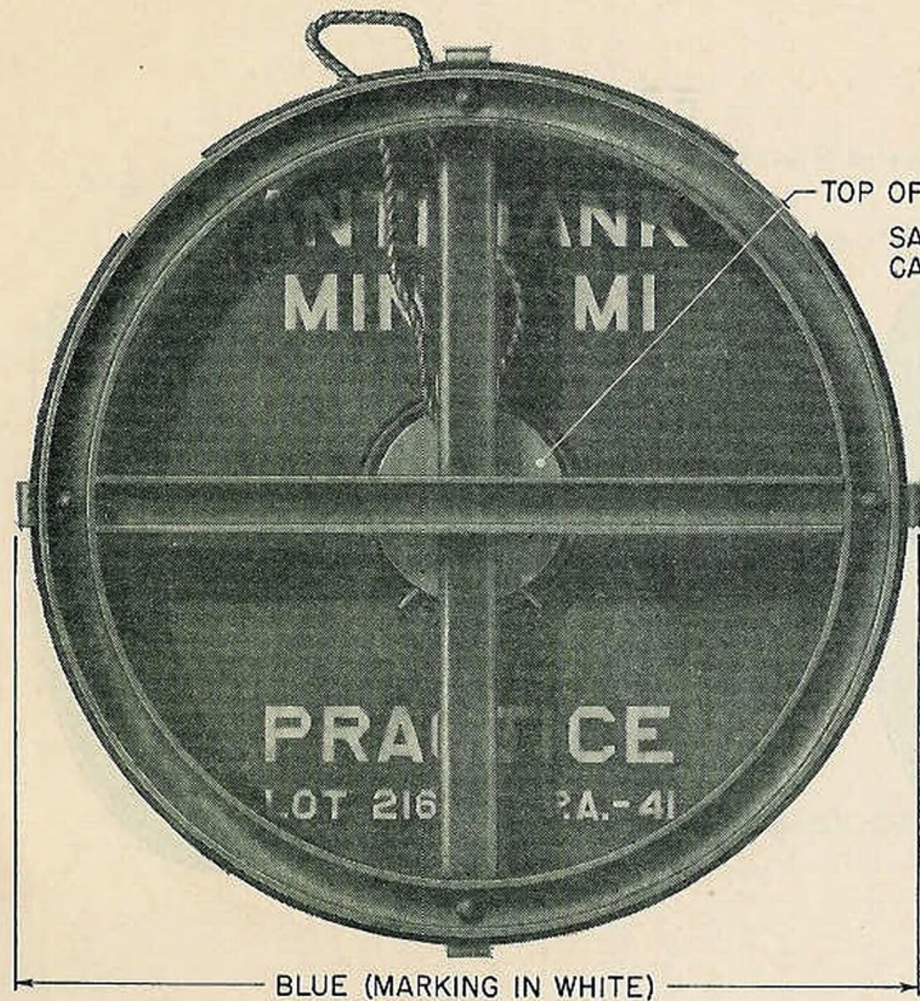

RA PD 4032

FIGURE 14.—Mine, antitank, practice, M1.



FIGURE 15.—Mine, antitank, components.

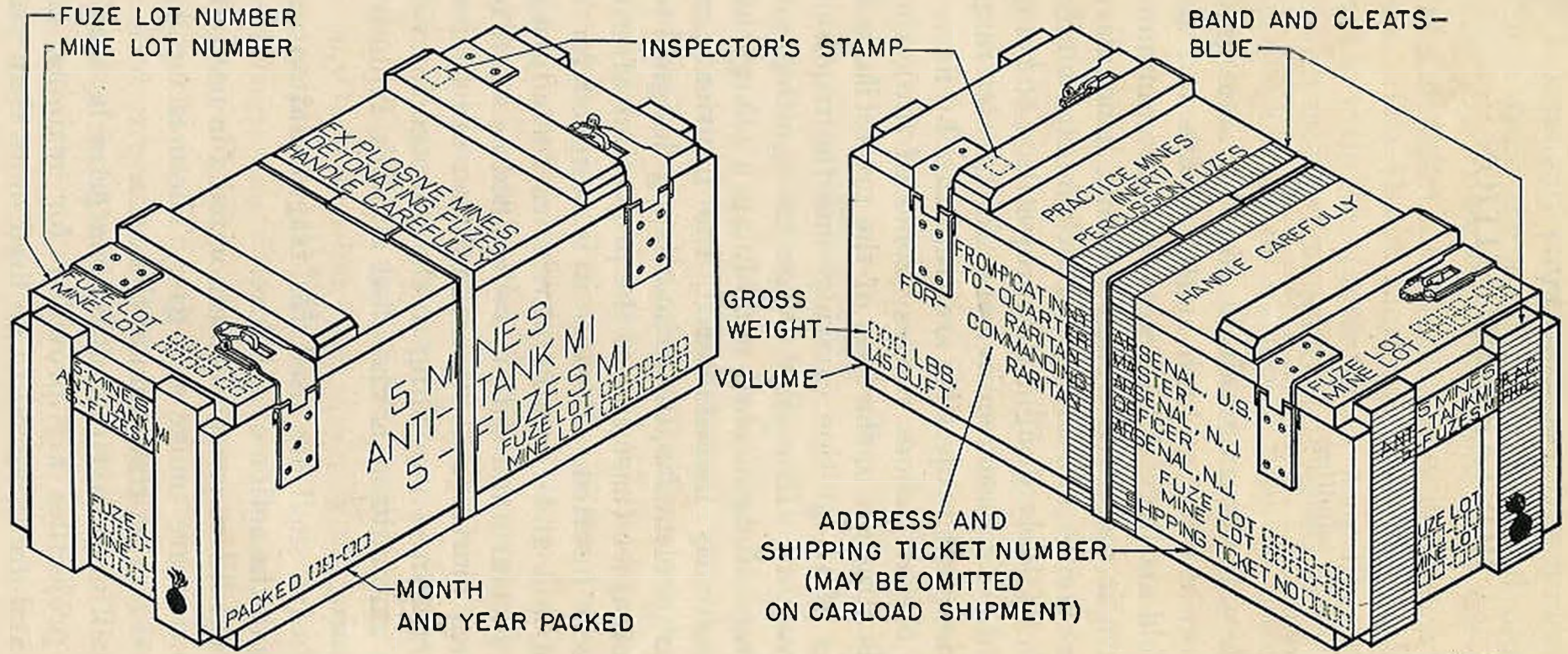

AMMUNITION, GENERAL

FIGURE 16.—Packings for antitank mines.

RA PD 4030

## SECTION IV

## MORTAR AMMUNITION

	Paragraph
General-----	71
Classification-----	72
Description-----	73
Care and precautions in handling-----	74
Packing and marking-----	75

**71. General.**—Mortar ammunition (fig. 17) is designed for firing from smooth-bore cannon at high angles of fire and at ranges less than those of field artillery. Such weapons and ammunition are particularly effective in stabilized trench warfare, hence have been commonly known as trench mortars and trench mortar ammunition. In the ammunition of early design, the projectile, not being stabilized, tumbled in flight. To meet requirements for greater range and accuracy, recently designed projectiles are stabilized by fins. To provide for high angle fire at various ranges (zones of fire), the propelling charge, which is attached to the base of the projectile, is divided into parts, consisting of an ignition cartridge and the required number of propellant increments. In earlier design the ignition cartridge consisted of a primed shotgun shell containing a charge of propelling powder. As currently manufactured, the ignition cartridge and primer are separate elements, the primer being designed to screw into the cartridge container (base end of the projectile) after the ignition cartridge has been inserted. Because it is designed for loading into the mortar as a unit and contains provisions for adjusting the propelling charge, mortar ammunition is classified as semifixed ammunition. The 3-inch mortar and its ammunition are limited standard.

**72. Classification.**—According to the purpose for which it is intended, mortar ammunition is classified as high explosive, chemical, practice, or training.

*a.* High explosive shell are used for fragmentation or demolition effect according to the action of the fuze.

*b.* The chemical fillers currently authorized for use only in 81-mm mortar ammunition are smoke and gas. There is no chemical filler authorized for 60-mm mortar ammunition.

*c.* Practice shell may have a spotting charge or be inert.

*d.* Training projectiles are provided for training and practice. They are inert and are designed to be fired more than once. Several propelling charges are supplied with each projectile.

**73. Description.**—*a. General.*—Two general types of ammunition are authorized for use in the 81-mm mortar and 3-inch trench mortar. That originally designed for the 3-inch trench mortar is limited



standard and is commonly known as 3-inch trench mortar ammunition to distinguish it from the ammunition designed originally for the 81-mm mortar. Under certain restrictions as to use of the full propelling charge (see below), both types of ammunition may be used in either weapon. The 81-mm mortar ammunition is issued as fuzed complete rounds with full (outer zone) propelling charge, whereas the 3-inch trench mortar ammunition is issued as unassembled complete rounds which must be assembled prior to firing. The 60-mm mortar ammunition is issued as fuzed complete rounds, similar to the 81-mm mortar ammunition.

*b. 81-mm mortar ammunition.*—Because of its stabilizing fins, this ammunition (fig. 17), even though fired from a smooth-bore mortar, is stable in flight and strikes nose first. A point-detonating type of fuze is fitted to the nose of the shell. The propelling charge, consisting of an ignition cartridge and propellant increments, is attached to the base end of the projectile. The increments are removable to provide for zone firing. When fired in the mortar, trench, 3-inch, Mk. IA2, the full (outer zone) propelling charge will be reduced as prescribed in the firing table.

*c. 3-inch trench mortar ammunition.*—This ammunition, which is limited standard (fig. 17), has no stabilizing fins, and because it is fired in a smooth-bore mortar which imparts no rotation to the projectile, is unstable in flight and may strike the target in any position—nose first, base first, or on its side. Hence it requires a fuze which will function regardless of the position of the projectile at the instant of impact. Such a fuze, known as the “Always,” is provided for assembly to the nose of the shell. The propelling charge, consisting of an ignition cartridge and propellant increments in the form of powder rings, must be attached to the base of the projectile prior to firing. The full (outer zone) propelling charge of this ammunition may be used when fired either in the mortar, 81-mm, M1, or mortar, trench, 3-inch, Mk. IA2.

*d. 60-mm mortar ammunition.*—Except for size, this ammunition is of the same general design as the 81-mm mortar ammunition. A typical round is shown in figure 17.

**74. Care and precautions in handling.**—General precautions given in chapters 1 and 3 will be observed. In addition the following will be complied with:

*a.* Complete rounds, being fuzed, will be handled with due care at all times. The explosive elements in primers and fuzes are particularly sensitive to shock and high temperature.

*b.* Just before firing and at no other time, the safety (cotter) pin will be withdrawn from the fuze.

AMMUNITION, GENERAL

A-CALIBER OF MORTAR  
 B-TYPE OF FILLER  
 C-MODEL OF SHELL  
 D-AMMUNITION LOT NUMBER

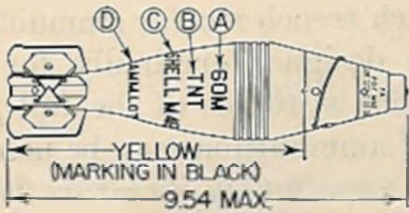

RA PD 3991

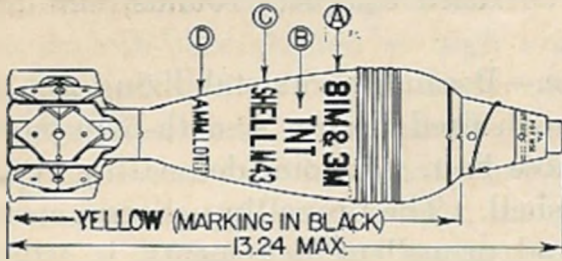

RA PD 3992

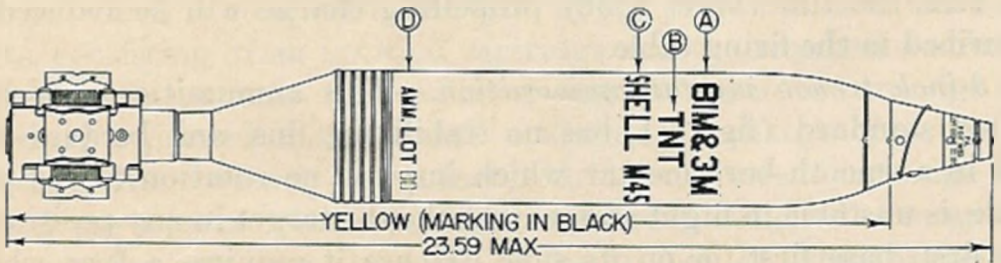

RA PD 3993

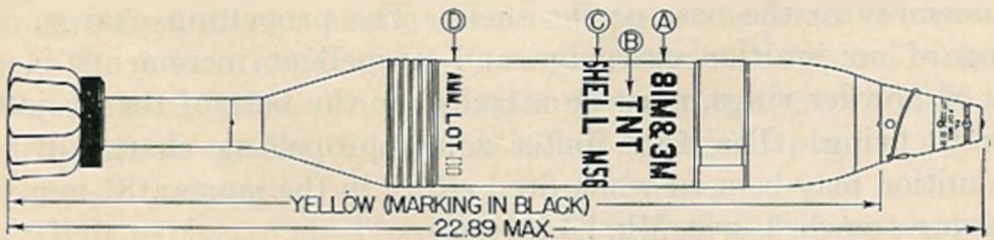

RA PD 3994

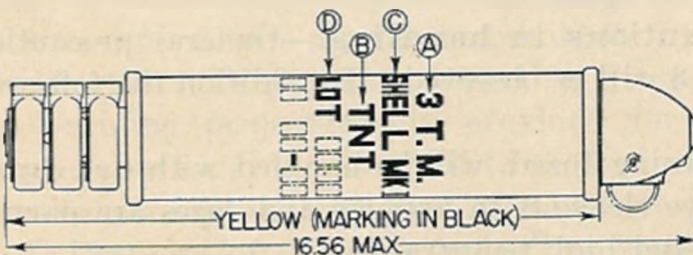

RA FSD 448

FIGURE 17.—Types of mortar shell.

c. When firing, the round is inserted into the mortar, cartridge end first. When the shell is released to slide down the barrel, the hands should be promptly removed from the muzzle.

d. Duds should not be handled or moved. They should be destroyed as described in chapter 4.

**75. Packing and marking.**—*a. Packing.*—Ammunition of current design for 60-mm and 81-mm mortars is packed as assembled complete rounds, each in an individual fiber container and these, in turn, in bundle packings; 18 rounds of 60-mm shell per bundle, and 3 or 6 rounds of 81-mm shell, depending upon the weight. Ammunition of earlier design for 3-inch trench mortars is packed as unassembled complete rounds, 3 per box, with one extra propelling charge.

*b. Marking.*—In addition to the painting which identifies the ammunition as to type, the following information is stenciled on the projectiles:

- (1) Caliber and type of mortar in which fired.
- (2) Kind of filler.
- (3) Model of shell.
- (4) Ammunition lot number.

c. Further information will be found in chapters 1 and 3 and in FM 23-85 and 23-90.

## SECTION V

### ARTILLERY AMMUNITION

	Paragraph
General.....	76
Classification.....	77
Identification.....	78
Projectiles.....	79
Fuzes.....	80
Adapters and boosters.....	81
Propelling charges.....	82
Cannon primers.....	83
Igniters.....	84
Blank ammunition.....	85
Care and precautions in handling.....	86
Packing and marking.....	87

**76. General.**—*a. Complete round.*—The term “artillery ammunition” includes ammunition used in cannon of all calibers. It includes complete rounds and components thereof. The complete round comprises all of the components necessary to fire the cannon once. These components are, in general, the fuzed projectile, the propelling charge, and the primer. Depending upon both the type of propelling charge and the method of loading into the cannon, complete rounds of artillery ammunition are known as fixed, semifixed, or separate loading.

*b. Fixed ammunition.*—Complete rounds in which the propelling charge is fixed, that is, not adjustable, and which are loaded into the cannon as a unit, are known as “fixed” ammunition (fig. 18). As usually designed, the propelling charge is assembled loosely in the cartridge case, which is crimped rigidly to the projectile. The primer is fitted in the base of the cartridge case.

*c. Semifixed ammunition.*—Complete rounds in which provision is made for adjusting the propelling charge to the zone to be fired and which, like fixed ammunition, are loaded into the cannon as a unit, are known as semifixed ammunition (fig. 18). In the usual design of this type of ammunition, the propelling charge is divided into parts known as increments. Each such part of the charge is assembled in a bag. The full charge is assembled in the cartridge case in the base of which is the primer. The neck of the cartridge case is a free fit over the base of the projectile, hence, when it is necessary to adjust the propelling charge, the projectile is readily lifted from the cartridge case. After the unnecessary increments have been removed, the projectile is reassembled to the cartridge case and the round is loaded into the cannon as in the case of fixed ammunition.

*d. Separate loading ammunition.*—Complete rounds in which the separate components—projectile, propelling charge, and primer—are loaded into the cannon separately are known as “separate loading” ammunition (fig. 18). Although the propelling charge may be in one section, it is usually divided into parts with each part assembled in a bag. While rather uncommon in our service, the propelling charge may be contained in a cartridge case instead of bag, but in such instance the cartridge case is not fitted to the projectile, but is loaded into the cannon separately.

**77. Classification.**—Artillery ammunition is classified according to use as service, practice, blank, or drill. It is also classified according to filler as explosive, chemical, or inert.

*a. Service ammunition* is that which is fired for effect. It may be high explosive or armor-piercing (shell), low explosive (shrapnel), chemical (gas or smoke), or inert (canister and smaller caliber of armor-piercing shot).

*b. Practice ammunition* has a propelling charge but the projectile may contain a low explosive spotting charge or may be inert.

*c. Blank ammunition* is provided in small and medium calibers for such purposes as saluting and simulated fire. It contains no projectile.

*d. Drill ammunition* is provided for practice in loading and handling. It is inert.

**78. Identification.**—In common with other types, artillery am-

munition is identified by painting, marking, and the accompanying ammunition data card. Further information will be found in paragraphs 7 and 87.

**79. Projectiles.**—*a. General.*—Although differing in characteristic details, all artillery projectiles are of the same general shape, that is, they have a cylindrical body and an ogival head. The principal characteristic differences are—

- (1) Location of fuzes—point or base.
- (2) Radius of ogive—smaller for low, larger for high velocity projectiles.
- (3) Rotating band—narrow for low, wide for high velocity.
- (4) Base—"boat-tailed" or "square base."
- (5) Armor-piercing cap—used only with armor-piercing projectiles.
- (6) Windshield or false ogive—where required for improved ballistics.

*b. Components.*—A projectile with principal parts named is shown in figure 20. These parts are described below.

(1) *Ogive.*—The curved portion of the projectile from the bourrelet to the point is called the ogive. The radius of the ogive is generally expressed in calibers, a caliber being the diameter of the bore of the gun. The radius of the ogive influences the flight of the projectile and in present designs generally varies from 6 to 11 calibers radius.

(2) *Bourrelet.*—The bourrelet is the accurately machined part, of slightly larger diameter, at the forward end of the body, which bears on the lands of the bore. The clearance between the diameter of the bourrelet and the bore diameter of a new cannon varies with the caliber from 0.005 inch for a 37-mm projectile to 0.020 inch for a 16-inch projectile.

(3) *Body.*—While applicable to the entire projectile, the term body is used to designate the cylindrical portion of the projectile between the bourrelet and the rotating band. It is machined to a smaller diameter than the bourrelet to reduce the surface in contact with the lands of the bore. Only the bourrelet and rotating band bear on the lands.

(4) *Rotating band.*—The rotating band is a cylindrical ring of copper or gilding metal, pressed into a groove near the base of the projectile. As the projectile moves forward in the bore, the rotating band is engraved by the rifling, and causes the rotation of the projectile necessary to maintain stability in flight. In addition, by completely filling the grooves, the band prevents the escape of gases past the projectile.

(5) "*Square base*" and "*boat-tailed.*"—When the surface to the rear

of the rotating band is cylindrical, the projectile is described as having a "square base"; when tapered or conical, it is known as "boat-tailed."

(6) *Base plug*.—To facilitate manufacture, armor-piercing projectiles are designed to be closed at the base end with a heavy steel plug. The base plug also provides a seat for the fuze and fuze plug.

(7) *Base cover*.—Projectiles containing a high explosive filler are provided with a base cover (fig. 22)—a thin metal disk covering the base of the shell—to prevent the hot gases of the propelling charge from coming in contact with the explosive filler through joints or possible flaws in the metal of the base.

(8) *Armor-piercing cap*.—The armor-piercing cap is of forged alloy steel, heat-treated to have a hard face and relatively soft core. On impact, the hardened face of the cap destroys the hardened surface of the armor plate while the softer core of the cap protects the hardened point of the projectile by distributing the impact stresses over a large area of the head.

(9) *Windshield*.—The windshield, made of steel or aluminum, is secured to the cap or head of the projectile to give improved ballistics.

(10) *Location of fuze*.—High explosive shell, designed for blast, fragmentation, or mining effect against unprotected targets, require a point-detonating fuze either of superquick or delay action. Armor-piercing shell, designed for use against protected targets, must first penetrate the protective armor, then explode, hence require base-detonating fuzes either of delay or nondelay action.

(11) *Tracer*.—For observation of fire, some shell are equipped with a tracer. In some models, the tracer is used to ignite the filler and destroy the shell in case the shell misses the target.

*c. Types of projectiles*.—Classified according to type, projectiles are known as high explosive, armor-piercing, chemical, shrapnel, canister, target practice (including subcaliber), and drill.

(1) *High explosive shell (HE)*.—These projectiles (fig. 21), are made of steel and contain a relatively large charge of high explosive filler. They are fitted with a base cover and usually designed for a point-detonating fuze.

(2) *Armor-piercing projectile (AP)*.—This type of projectile is designed to penetrate armor plate and may or may not have an explosive filler. An armor-piercing cap is fitted over the ogive and a windshield over the cap. Those AP projectiles containing an explosive charge have thick walls and a relatively small amount of explosive filler. The base of explosive projectiles is closed by a base plug into which the fuze is fitted and the whole covered by a base cover.

(3) *Chemical shell*.—Chemical shell, in general, are similar to high explosive shell, differing principally in the manner of assembling the

adapter and burster-well, which must be gastight to prevent leakage of the chemical filler. In some designs this was accomplished by tapered pipe threads, while in other designs these parts are assembled with straight threads or force-fit, and welded. A typical chemical shell is shown in figure 23.

(4) *Shrapnel*.—Shrapnel (this type is shown in section in fig. 24) is designed to function in flight and is therefore equipped with a time fuze. The functioning of the fuze at a predetermined point along the trajectory ignites a black powder charge in the base. This charge projects the filler of metallic balls forward in a cone of dispersion, without rupturing the case. Although some shrapnel are still in service, they are almost entirely superseded by high explosive shell.

(5) *Canister*.—A canister consists of a light metal case, filled with steel balls, containing no explosive charge. It breaks upon leaving the muzzle of the cannon, allowing the balls to scatter.

(6) *Target-practice projectiles*.—(a) Cast-iron shot and sand-loaded shell, of the same size, shape, and weight as service shell, are provided for target practice. Some models contain a smoke-puff charge and others are inert. (See fig. 25.)

(b) Subcaliber ammunition is fixed ammunition with special projectiles provided for training in elevating, traversing, and sighting the piece to which the subcaliber equipment pertains. Its advantage lies in the fact that it is more economical and may be used in relatively congested areas.

(7) *Drill projectiles*.—Inert projectiles and complete rounds for training are known as dummy or drill ammunition. They are used for training and practice in handling shell and in the service of the piece. A typical drill projectile is illustrated in figure 26.

80. *Fuzes*.—a. *General*.—A fuze is a mechanical device used with a projectile to explode it at the time and under the circumstances desired. (See figs. 27, 28, 29, and 30.)

b. *Types*.—(1) Fuzes are classified according to position on the projectile as “point” or “base.”

(2) Fuzes are further classified as time, impact, or a combination of both. Time fuzes contain a graduated time element in the form of a compressed black powder train or a mechanism similar to a watch, which may be set to a predetermined time, prior to firing. Impact fuzes function on impact with the target. If the fuze is designed to function on impact with a very light matériel target, such as an airplane wing, it is called “supersensitive.”

(3) Impact fuzes are further classified as superquick and delay, depending upon their quickness of action.

NOTE.—The terms “superquick” and “delay” are used in reference to the action at the instant of impact, whereas “time” refers to time after the instant of firing.

(4) Depending upon the mechanism of arming, certain fuzes are considered "bore-safe," that is, the explosive train is so interrupted that, even if the more sensitive elements should function prematurely, the projectile cannot explode until after it leaves the muzzle of the cannon.

*c. Arming.*—In general, all artillery fuzes are in an unarmed condition prior to firing although in a strict sense time fuzes are always armed despite the mechanical restraint which prevents initiation of time action. Fuzes of the impact type are usually armed by centrifugal force acting on parts of the fuze after the projectile leaves the muzzle. The time element of time fuzes is initiated at the instant of firing by "set-back" (see app. I). To prevent accidental arming during handling and shipping, safety devices such as a safety wire or cotter pin are used when required. Such safety devices are to be removed prior to firing.

**81. Adapters and boosters.**—*a. Adapters.*—An adapter is a steel bushing fitted to the nose of a shell and threaded to receive the fuze.

*b. Boosters.*—The term "booster" is applied to one of the explosive elements in the bursting charge explosive train. It consists essentially of the booster explosive in a metal case. In some designs the booster is a part of the shell loading assembly, in others it is assembled to the fuze as shipped. Tetryl is the most commonly used booster explosive. The corresponding explosive element in chemical shell which opens the shell and disperses the chemical agent is called a "burster."

*c. Adapter-boosters.*—When a booster is assembled to an adapter, the combination is known as an adapter-booster. In general, adapters and boosters are components assembled to the shell or fuze at the time of manufacture and are not shipped separately for assembly in the field.

**82. Propelling charges.**—*a. General.*—In general, propelling charges (figs. 18 and 32) consist of a charge of smokeless (NH or FNH) powder, with an igniter charge of black powder, assembled in a suitable container. The powders used as propellants are described in section III, chapter I. The nature of the container depends upon the design of the ammunition. In the case of small-arms and fixed ammunition, the cartridge case, crimped rigidly to the bullet or projectile, serves as the container for the charge, which is assembled loosely therein. In semifixed artillery ammunition, the charge, being divided into parts or increments for zone firing, is assembled with each increment in a cloth bag. The full charge, with all increments in proper order, is assembled in the cartridge case which, for this kind of ammunition, is a free fit over the end of the projectile. In semifixed mortar ammunition, the increments, consisting of bundles of sheet powder, are nested between the blades of the fins. The ignition



cartridge contains the igniter charge. In small-arms ammunition, the fire from the primer is adequate to ignite properly the small grains of the propellant, hence an igniter is not required. In fixed and semi-fixed ammunition, the igniter charge of black powder is contained in the outer end of the artillery primer which is fitted into the base of the cartridge case. In separate loading ammunition the propellant and the igniter are assembled in cloth bags. Depending upon the design of such charges, they are known as single section or multisection charges (fig. 32). Multisection charges are subdivided into "base and increment," "equal section," and "unequal section" types. Separate loading propelling charges, which are shipped and stored in cartridge storage cases (fig. 39), are further described below.

*b. Single section charge.*—In this type of charge (fig. 32), the propellant powder is contained in a single bag, tightly laced to give the charge rigidity. The igniting charge is divided into three parts, each in its own bag—two end pads and a core which extends axially through the center of the charge and connects the igniter pads sewed to each end.

*c. Base and increment charge.*—Charges of this type (fig. 32) have a base section and one or more increments. The increments may be of equal or unequal weights, but usually weigh less than the base section. With some types, one igniter pad is attached to the base end of the base section only, while other types have a core igniter running through the center of the base and each increment, with an igniter pad at the base end of the base section. Others have, in the base section only, a core igniter connecting an igniter pad on each end.

*d. Equal section charge.*—This type of charge (fig. 32) is also known as an "aliquot part charge." As the name implies, these charges are divided into a given number of equal sections. In those designs in which the igniter pad is separate, tying straps are provided for attaching the igniter to the propellant charge. In other designs the igniting charge is divided into parts, having an igniter pad at the base end of each section. In other types there is a longitudinal core igniter connecting with an igniter pad on each end of each section.

*e. Dummy charge.*—Dummy charges, simulating service charges, are provided for use with drill projectiles for the purpose of training personnel in the service of the piece.

*f. Cartridge bags.*—Silk has been found to be the most satisfactory material for cartridge bags, although wool, mohair, or cotton may serve as a substitute for lower grades of silk.

*g. Color.*—(1) In cases where two types of propelling charges are designed for one cannon—one for inner, the other for outer zones of fire—the cloth of the bags for the inner zone is dyed green to distin-

guish that charge from the other type which is assembled in undyed (white) bags.

(2) Bags of current manufacture used for the igniter charge are dyed red to indicate the presence of the black powder igniter. Those of earlier manufacture (undyed) are marked "IGNITER."

**83. Cannon primers.**—*a. General.*—A cannon primer, commonly called a "primer," is the component used to initiate the ignition of the propelling charge. Although made in various forms, it consists essentially of a small quantity of sensitive explosive and a larger quantity of black powder, encased in a metal container. The method of firing the sensitive explosive element and the quantity of black powder used depend upon the design of the propelling charge (fig. 35). In the case of fixed and semifixed ammunition, the primer (fig. 18) is in the form of a tube having a slightly enlarged head which is forced into the base of the cartridge case. In the case of separate loading ammunition, the primer is designed for insertion into the breechblock and is fired by percussion, friction, or an electric current. Based on the method of firing, cannon primers are classed as—

Percussion.

Friction.

Electric.

Combination percussion-electric.

Igniting.

*b. Percussion primer.*—This type of primer (fig. 36), designed to be fired by a blow of the firing pin, is generally used with all artillery ammunition except that for harbor defense and railway artillery. The primers used in cartridge cases contain sufficient black powder to ignite properly the smokeless powder in the cartridge case. Those used with separate loading propelling charges contain only enough black powder to ignite the black powder igniter attached to the propelling charge.

*c. Friction primer.*—This type of primer (fig. 36) is fired by the heat generated when a serrated plug is pulled through an explosive composition sensitive to heat or friction. At the present time it is used as a substitute for the electric primer in the event of failure of electric power.

*d. Electric primer.*—This type of primer (fig. 36) is fired by the heat generated when an electric current passes through a resistance wire embedded in a sensitive explosive composition. It is used only in harbor defense and railway artillery. Although both the friction and electric primers are very similar, the electric primer is distinguished by black insulation around the wire.

*e. Combination percussion-electric primer.*—This primer (fig. 36)

is designed to be fired either electrically or by a blow of the firing pin. It is used only in certain harbor defense and railway artillery.

*f. Igniting primer.*—This type of primer, although very similar to the percussion type, differs therefrom in that it contains an inert cap with a hole in it, in lieu of the percussion element. It is intended for use in certain subcaliber ammunition which is designed to be fired by a service primer. The flame from the service primer passes through the hole in the cap of the igniting primer, thus igniting the black powder charge in the igniting primer.

**84. Igniters.**—In the propelling charge explosive train, the igniter is the explosive (black powder) which intensifies the spit from the primer composition to the end that the propellant powder is ignited properly. The term "igniter" is more commonly used in referring to the igniter charge in the form of "pads" or "cores" attached to, or used with, separate loading propelling charges. The bags of such pads or cores of later manufacture are made of red cloth to distinguish them from the bags containing the propellant powder. (See figs. 33 and 34 and par. 82.) Prior to packing in a cartridge storage case, a cloth or paper "igniter protector cap" is placed over the igniter ends of separate loading propelling charges for protection during shipment and storage. Igniter protector caps must be removed prior to loading the charge into the cannon.

**85. Blank ammunition.**—*a. General.*—Blank ammunition is provided for cannon of caliber up to and including 105 mm, for practice purposes, for maneuvers, for firing the morning and evening gun, and for saluting. The regulations governing use of blank ammunition may be found in AR 210-10, AR 600-25, AR 600-30, and section II, Circular No. 213, War Department, 1941.

*b. Complete round.*—The complete round of blank ammunition consists of a cartridge case with primer, a charge of black powder, a felt wad, and a closing cup sealed in the mouth of the case. The cartridge case is usually made by trimming the service cartridge case to a suitable length. A typical round of blank ammunition is illustrated in figure 37.

**86. Care and precautions in handling.**—*a.* In addition to the precautions prescribed in chapter 3, the following will be observed:

*b.* Ammunition, especially the rotating bands and cartridge cases, will be protected from such damage as would affect their serviceability. A damaged rotating band will affect the flight characteristics of the projectile; a dented cartridge case may jam in the chamber.

*c.* The seals of airtight containers will not be broken until the ammunition is to be used, except as required for inspection.

*d.* Components containing sensitive explosives such as fuzes,

primers, and detonators will be protected from undue shock and high temperature.

*e.* No attempt will be made to disassemble fuzes in the field without specific instructions from the Chief of Ordnance.

**87. Packing and marking.**—*a. Packing.*—Except for calibers smaller than 75 mm, which are packed in a metal-lined box, fixed and semifixed ammunition is packed as assembled complete rounds in individual fiber or metal containers which are bundled or boxed (fig. 40). Separate loading ammunition is packed separately as follows:

(1) Unfuzed high explosive projectiles—with grommet to protect the rotating band, and eyebolt lifting plugs (fig. 23).

(2) Projectiles such as armor-piercing, having a windshield or false ogive—in a crate or box (fig. 41).

(3) Separate loading propelling charges—in airtight metal cartridge storage cases (fig. 39).

(4) Primers—in sealed metal or moisture-resistant containers and these, in turn, in metal-lined boxes (fig. 42).

(5) Fuzes with or without boosters—in individual waterproof or moisture-resistant containers and these, in turn, in wooden or metal-lined boxes.

*b. Marking.*—Artillery ammunition, in common with other types, is identified by the painting and marking and the accompanying ammunition data card (par. 8). The basic color scheme—yellow, high explosive; red, low<sup>a</sup> explosive; gray, chemical; blue, practice; black, drill—applies also to artillery ammunition. However, there are now on hand target practice projectiles of larger caliber which have been painted black. It is contemplated that when replacement or repainting is required, they will be painted blue in agreement with the basic color scheme. Armor-piercing projectiles which contain a high explosive filler are painted yellow; those too small to have a high explosive filler and fuze are painted black. The marking on the projectile includes—

Caliber and type of cannon in which fired.

Kind of filler (TNT, WP smoke, etc.).

Mark or model of projectile.

Weight zone marking.

Lot number.

Similar information is marked on other components. For examples of typical markings see figures 19, 23, 31, and 38. Further information will be found in the Technical Manuals and Field Manuals pertinent to the particular type and caliber of ammunition and weapon.

- ① - CARTRIDGE CASE
- ② - FUZE
- ③ - GROMMET
- ④ - LIFTING PLUG
- ⑤ - PRIMER
- ⑥ - PROJECTILE
- ⑦ - PROPELLING CHARGE
- ⑧ - ROTATING BAND
- ⑨ - BURSTING CHARGE

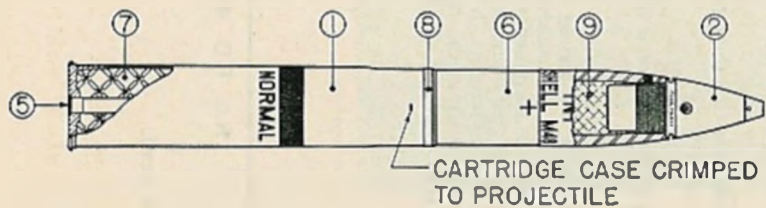

FIXED--A

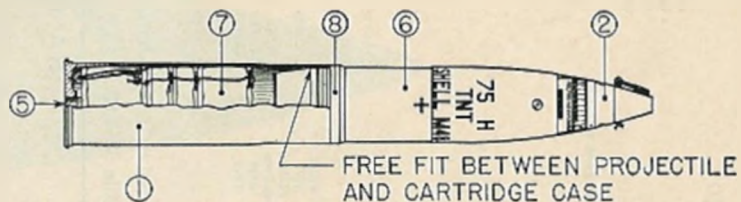

SEMIFIXED--B

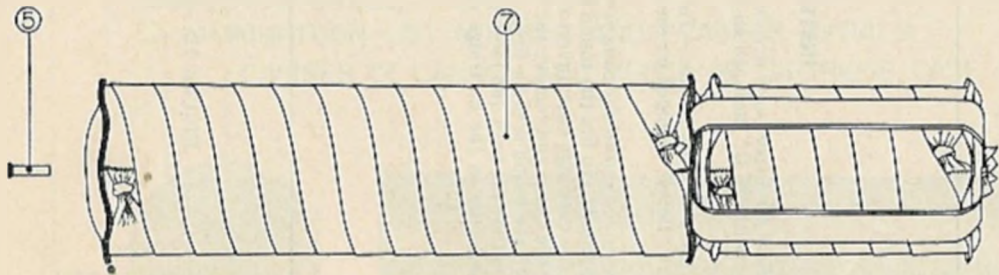

SEPARATE LOADING--C

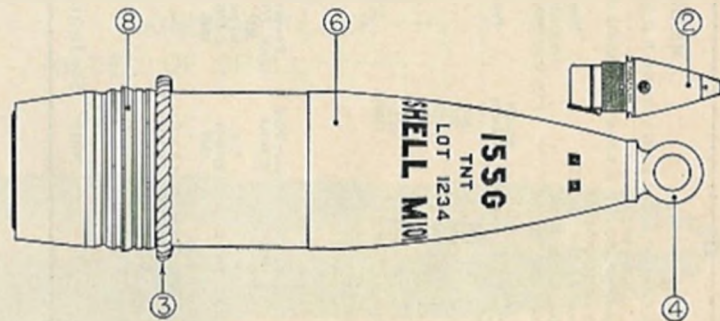

RA PD 3996

FIGURE 18.—Types of artillery ammunition.

AMMUNITION, GENERAL

AMMUNITION DATA CARD

Kind: Round, Complete, Shell, H. E., M1 (with M48 P. D. Fuze) for  
Howitzer, 105 mm., M2  
Complete Round Dwg. 75-1-75, P. R. 6-24-40 PXS-612 (Rev. 2)  
Assembled by Picatinny Arsenal  
Expected muzzle Velocity 1550 F. S. Pressure 27,700 lbs. per sq. in.  
Wt. of Propelling Charge 46 ozs. Projectile weight 33 lbs. as fired, approx., Zone xx.  
Contract No. Ord. 3319 P. A. E. O. 1257

Amm. Lot No. 3319-12  
Card No. 9524  
Quantity in Lot  
Date: Feb. 1941

Zone	Wt. Chg. By Zone Ozs.	Total Wt. Chg. Ozs.	Muzzle Velocity	Pressure
1	10.9	10.9	650	
2	2.0	12.9	710	
3	2.4	15.3	780	
4	3.4	18.7	875	
5	5.4	24.1	1020	
6	8.5	32.6	1235	
7	13.4	46.0	1550	27,700

Packed: 2 per box.

Remarks:

COMPONENTS

Data Kind	Cartr. Case M14	Primer Perc. M1B1A1	Powder Sunk., FNH M1 duPont X-4304	Projectile H. E. 105 mm. M1 F. A. 3311-8	Filler TNT Flaked duPont 2435 1941	Fuze P. D. M48 P. A. 3319-4 1940	Booster M20 P. A. 3319-1 1940
Manuf. Lot No	F. A. 3319-1	P. A. 2916-54	1940	F. A. 3311-8	duPont 2435 1941	P. A. 3319-4 1940	P. A. 3319-1 1940
Year Mfg.	1941			1941			
Date Filled	Zone Charge						
Disc. No	71-2-101	71-2-32		75-4-75		73-2-140	73-2-112
Rev. Date	3-7-35	8-6-38		3-20-39		5-23-39	P. R. 1-16-40

Certified to by: J. Johns Jr., Inspector

Note: See Instructions on Reverse Side of Card.

RA PD 4015-A

① Obverse.

INSTRUCTION CARD

*To set fuze for superquick action.*—Turn the setting sleeve so that the screw driver slot is in line with "S. Q." stamped on the ogive.

*To set fuze for delay action.*—Turn the setting sleeve so that the screw driver slot is in line with "Delay" stamped on the ogive.

*To prepare the round for zone firing.*—To fire the round in the highest zone, no change is required. To fire the round in a zone other than the highest, remove the projectile from the cartridge case; invert the cartridge case so that the increments will fall out. Break the twine and remove the increments marked with higher numbers than the zone in which the round is to be fired. Replace the remaining increments in the cartridge case so that the bags and loose ends of the twine are well down in the case. Replace the projectile in the cartridge case. NOTE: SEE DATA ON REVERSE SIDE OF CARD.

RA PD 4015-B

② Reverse.

FIGURE 19.—Ammunition data card.

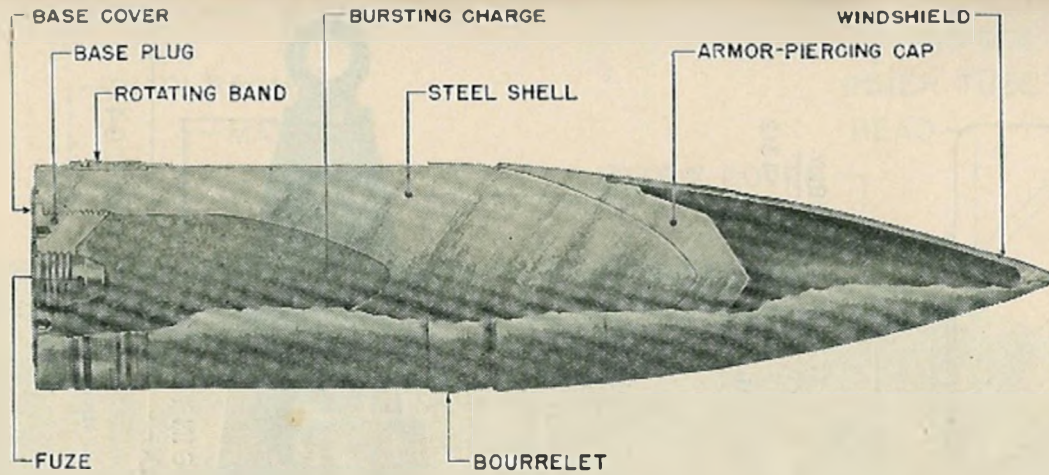

FIGURE 20.—Armor-piercing projectile.

RA PD 4034

61

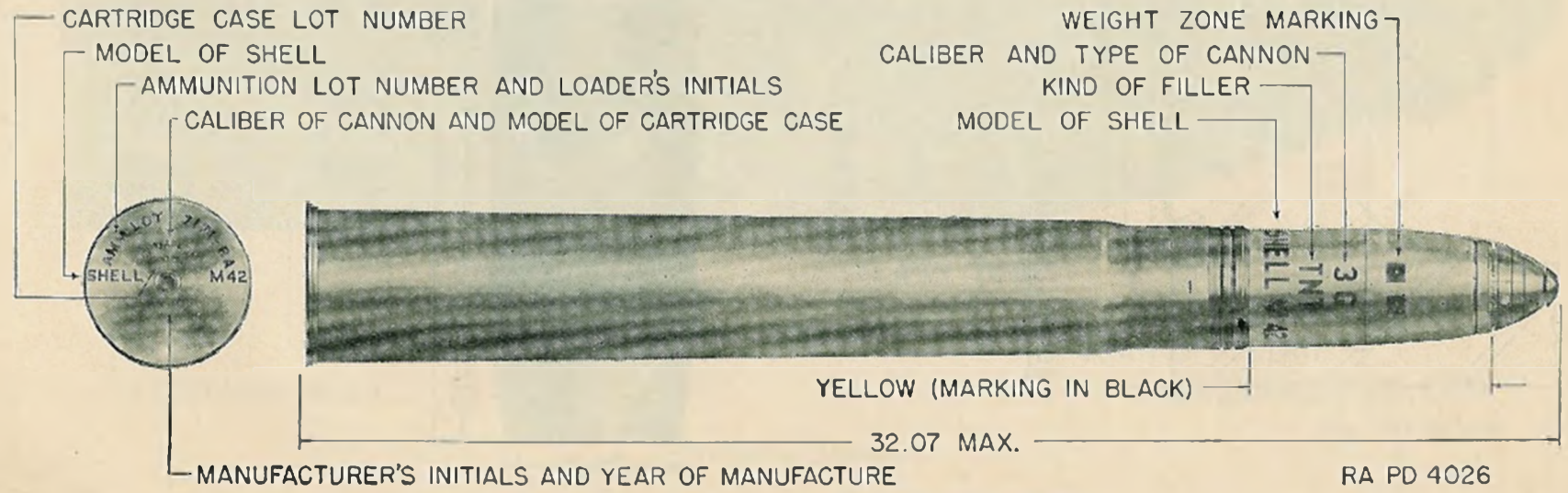
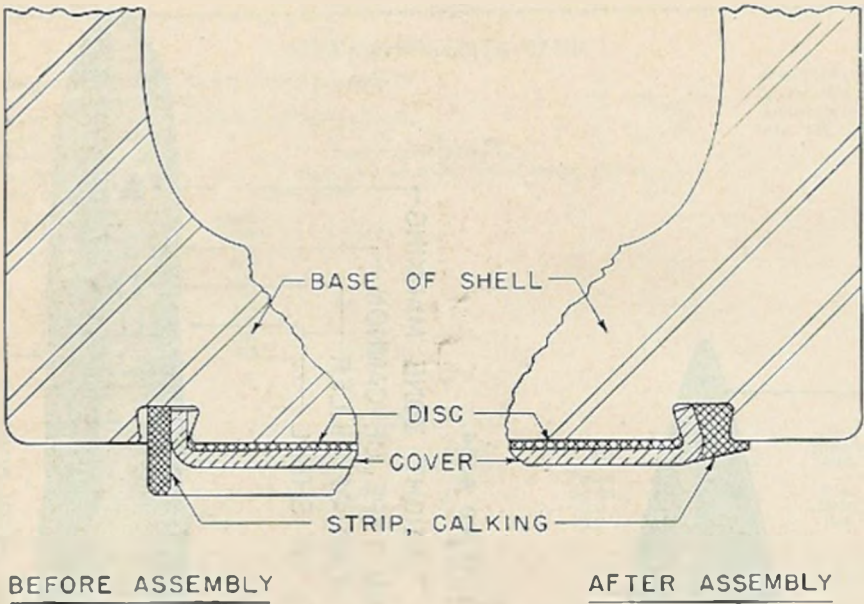

FIGURE 21.—Antiaircraft 3-inch high explosive projectile.

AMMUNITION, GENERAL



RA PD 4312

FIGURE 22.—Base cover detail.



RA FSD 1294

FIGURE 23.—Chemical shell.



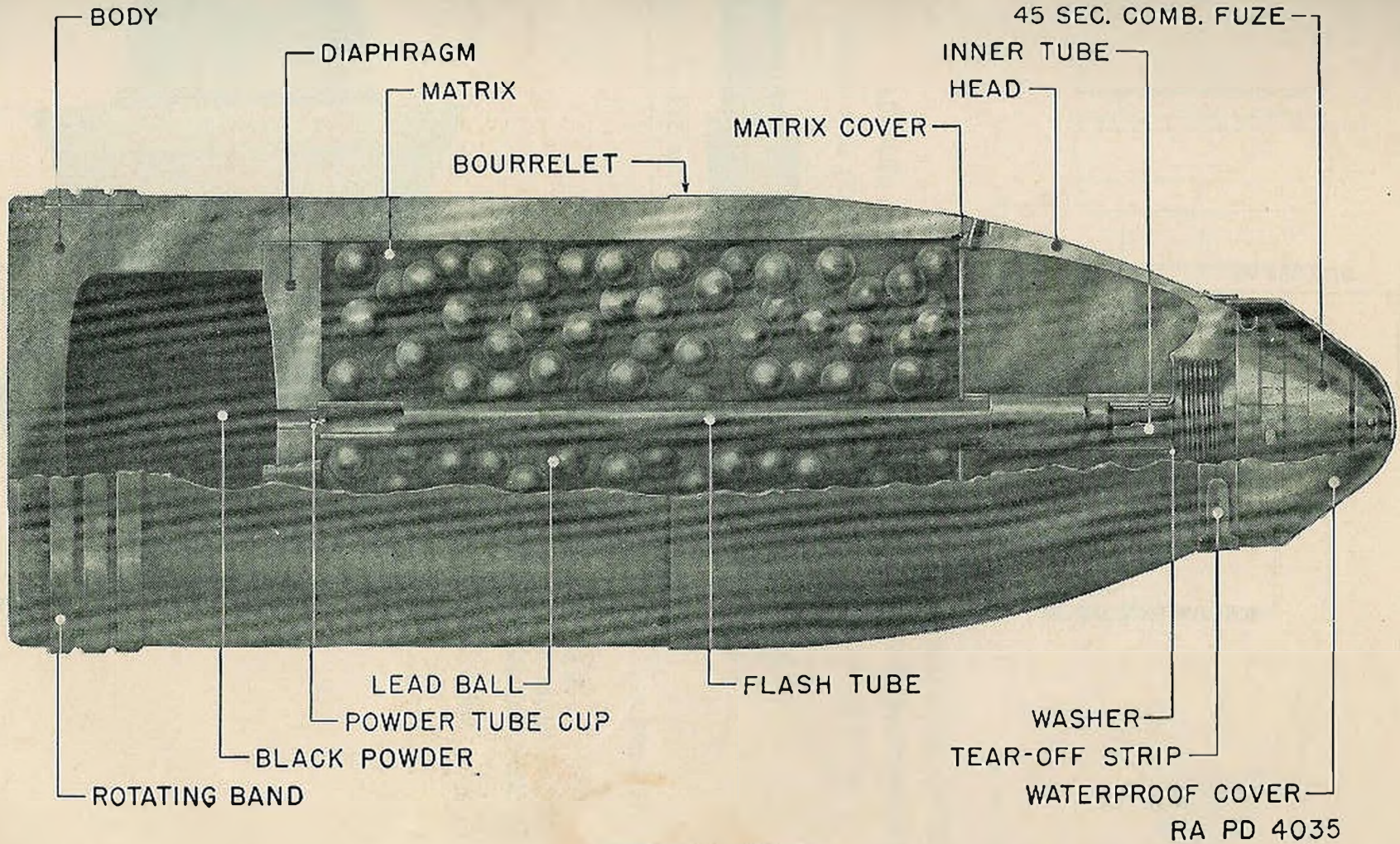

FIGURE 24.—Shrapnel.

RA PD 4035

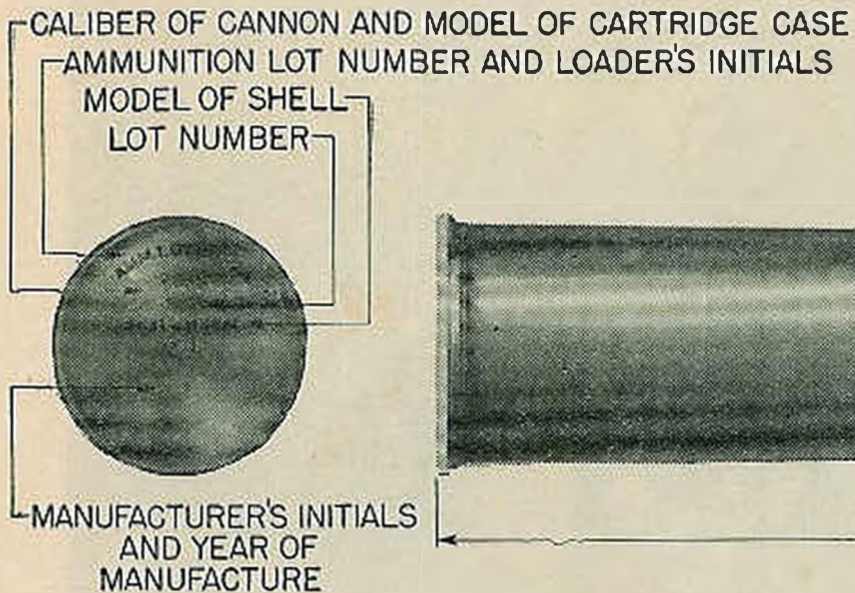
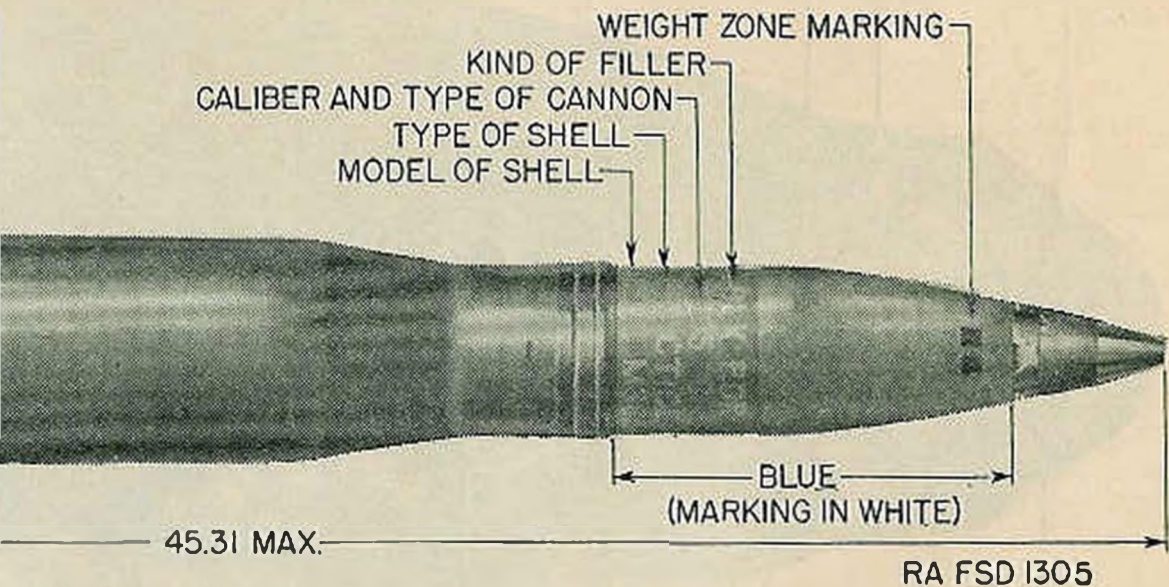

FIGURE 25.—



-Practice shell.

AMMUNITION, GENERAL

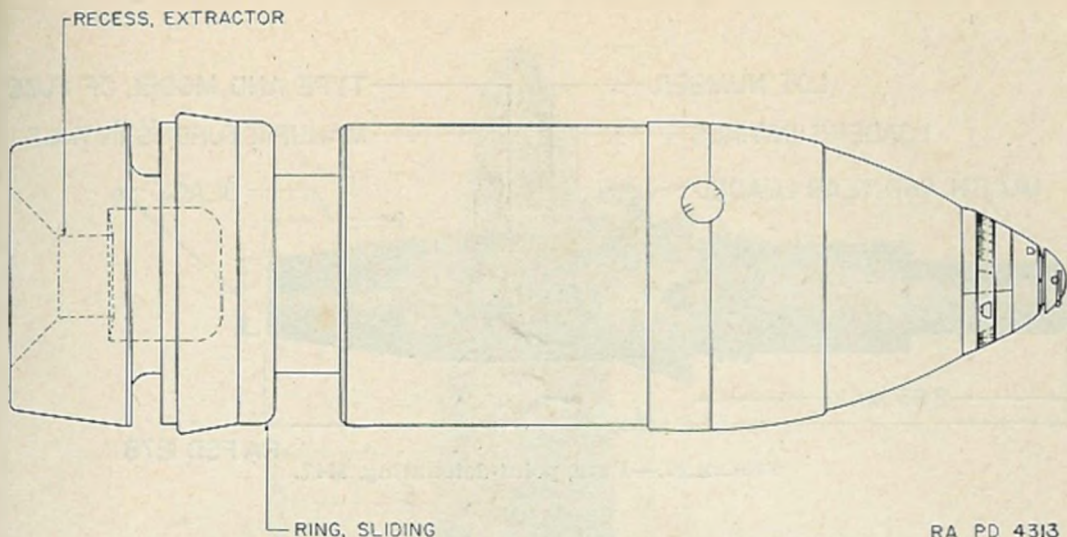

FIGURE 26.—Dummy shell.

RA PD 4313

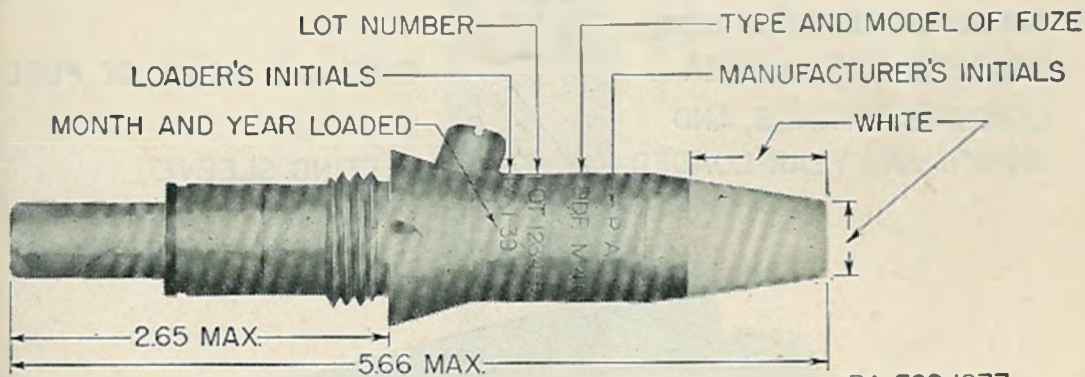

FIGURE 27.—Fuze, point-detonating, M46.

RA FSD 1277

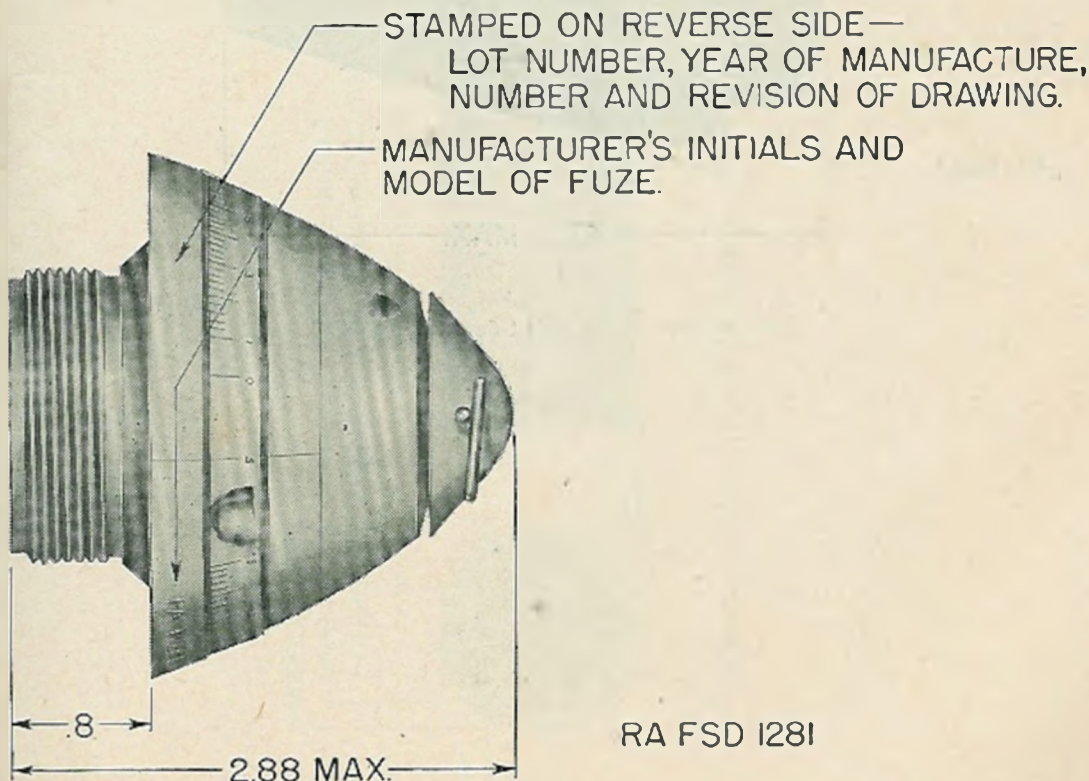

FIGURE 28.—Fuze, time, 45-second, M1907M.

RA FSD 1281

AMMUNITION, GENERAL

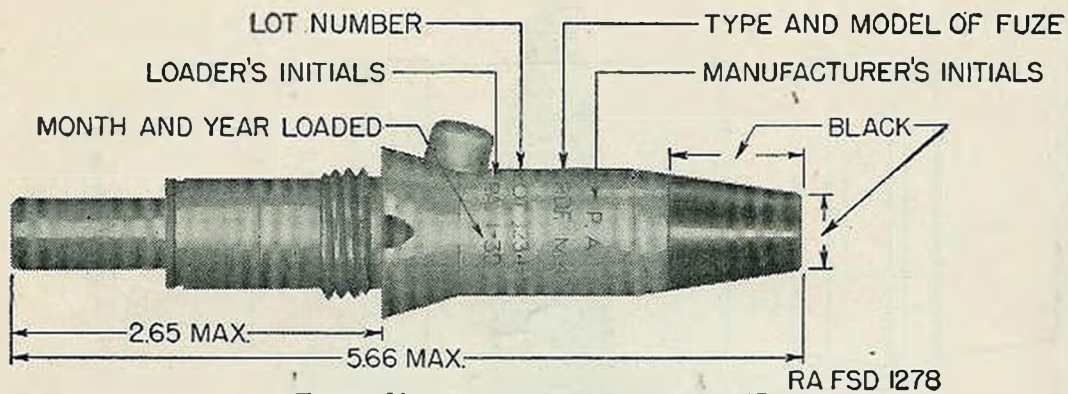

FIGURE 29.—Fuze, point-detonating, M47.

STAMPED ON REVERSE SIDE -

LOADER'S LOT NUMBER  
 LOADER'S INITIALS, AND  
 MONTH AND YEAR LOADED

TYPE AND MODEL OF FUZE

SETTING SLEEVE

81 MAX.

4.55 MAX.

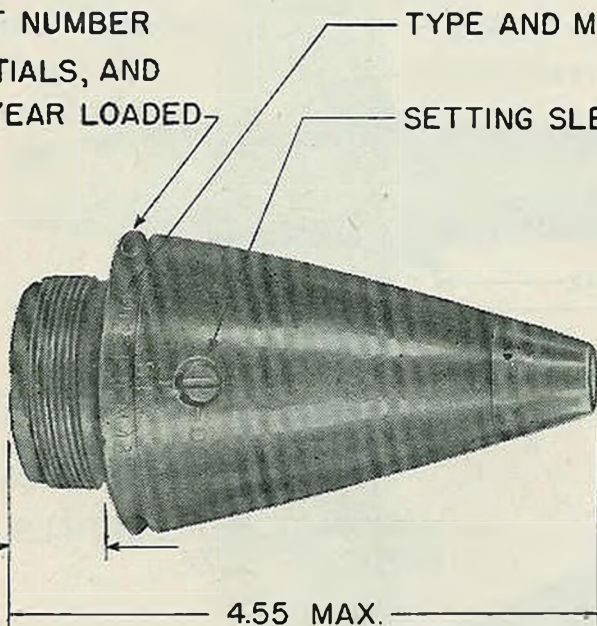

FIGURE 30.—Fuze, point-detonating, M48.

RA PD 3990

67

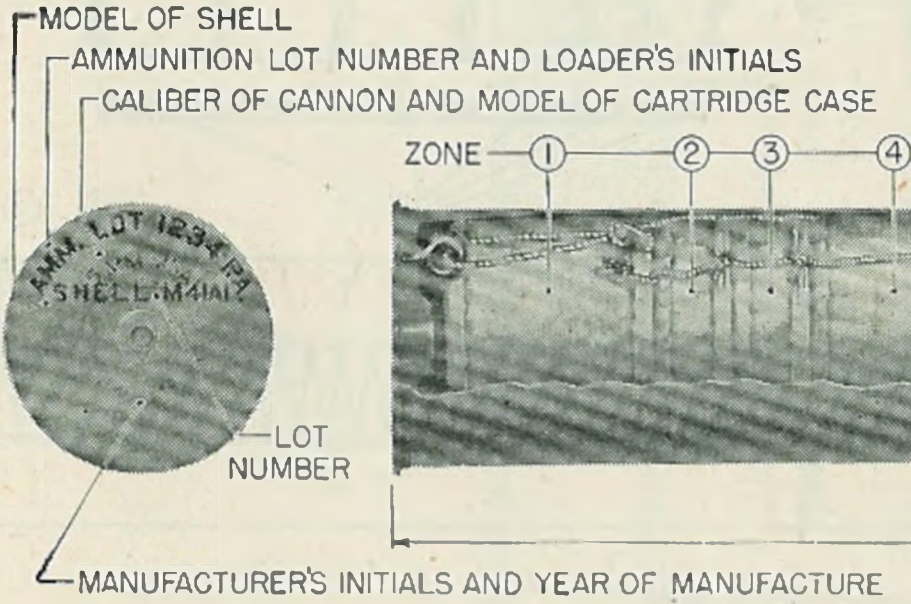
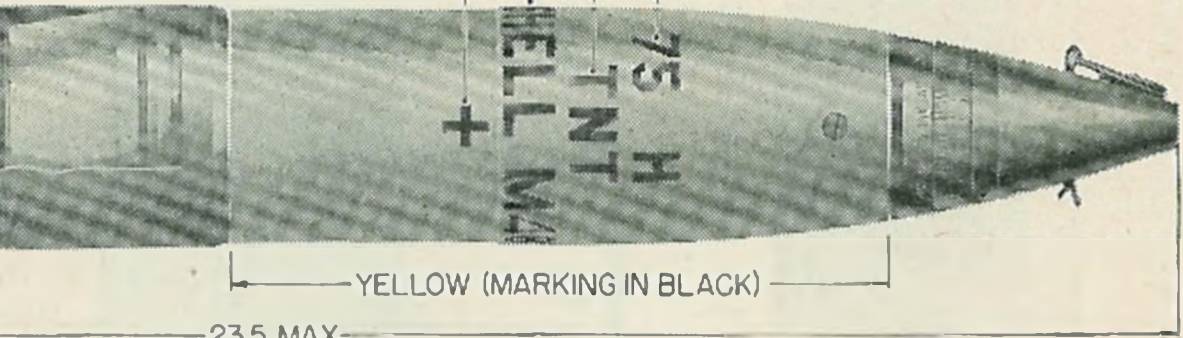

FIGURE 31.—

CALIBER AND TYPE OF CANNON  
KIND OF FILLER  
MODEL OF SHELL  
WEIGHT ZONE MARKING



YELLOW (MARKING IN BLACK)

23.5 MAX.

RA FSD 1301

Semifixed ammunition.

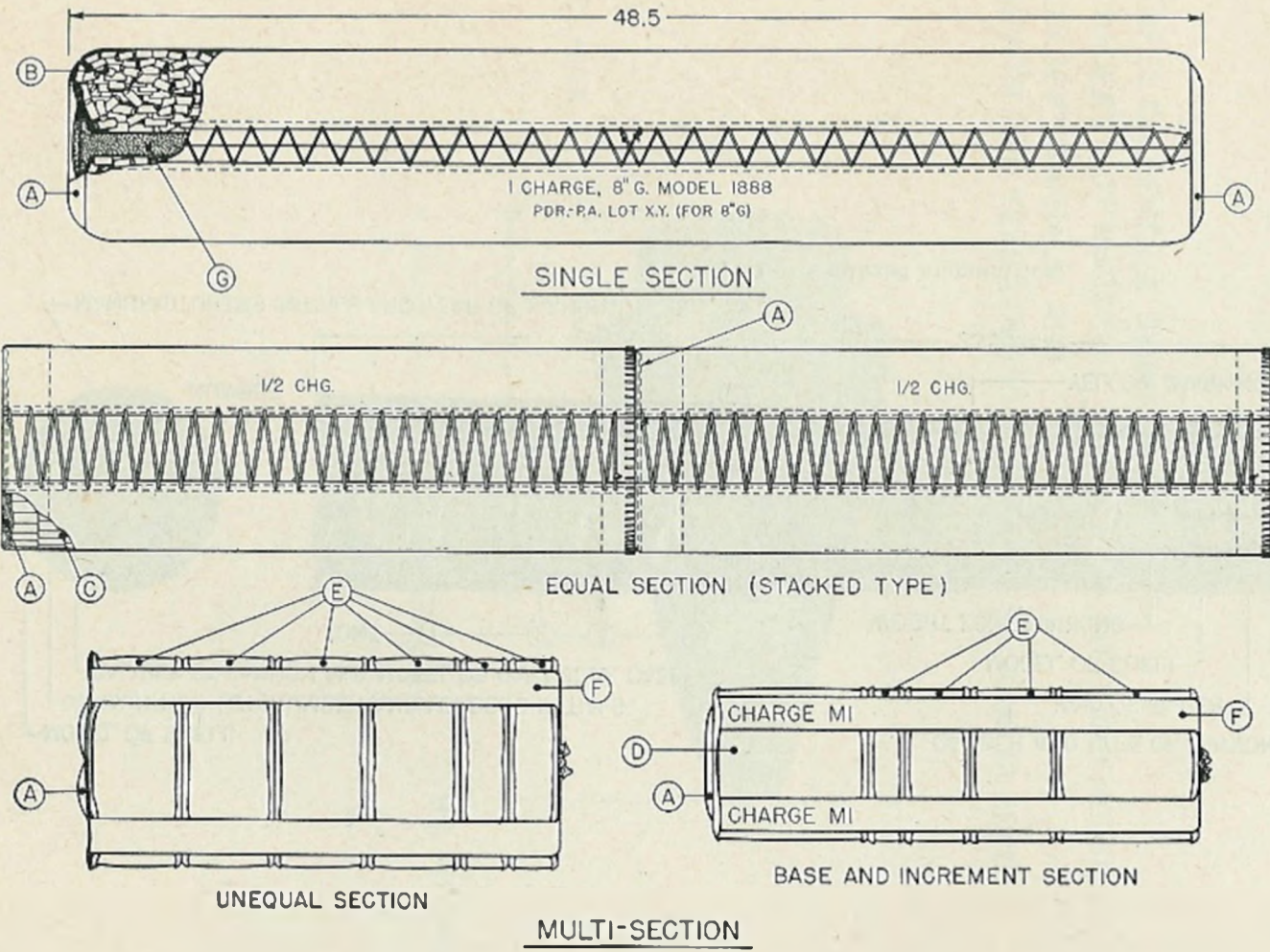

- (A) - IGNITER-BLACK POWDER
- (B) - LOOSE GRAINS OF SMOKELESS POWDER
- (C) - STACKED GRAINS OF SMOKELESS POWDER
- (D) - BASE SECTION
- (E) - INCREMENT SECTION
- (F) - TYING STRAP
- (G) - IGNITER CORE

68

FIGURE 32.—Propellent charges.



AMMUNITION, GENERAL

ZONE NUMBER MARKED ON TOP OF INCREMENT

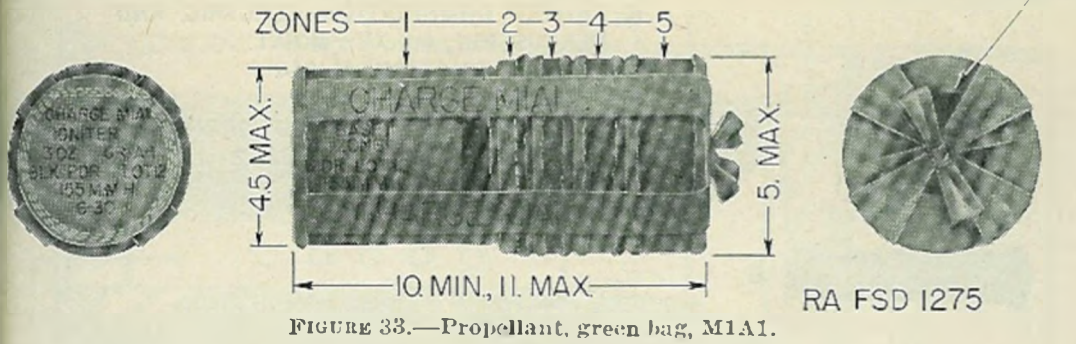

ZONE NUMBER MARKED ON TOP OF INCREMENT

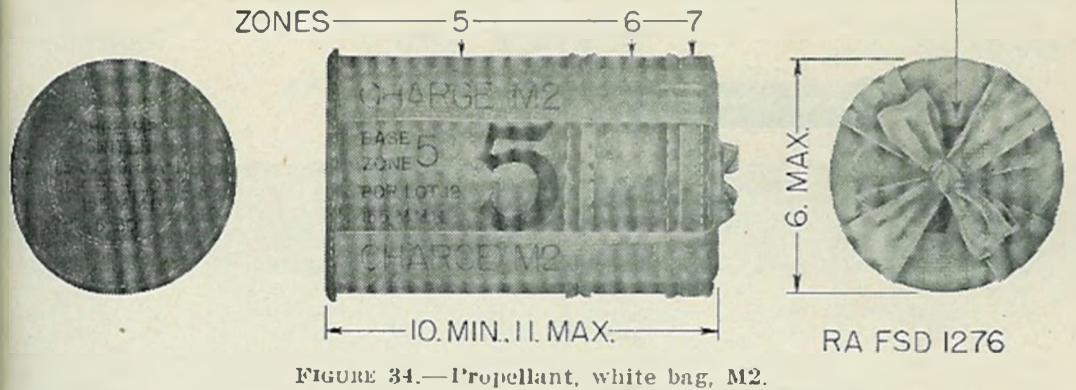

LOADER'S INITIALS, LOT NUMBER AND YEAR OF LOADING

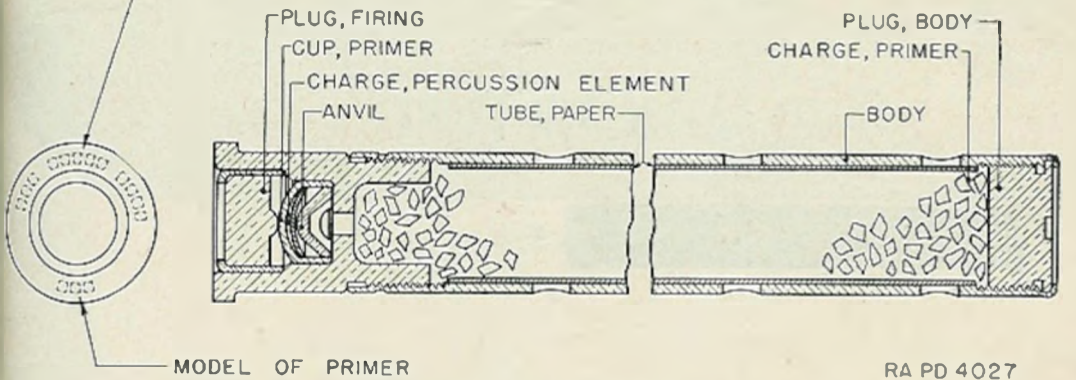

AMMUNITION, GENERAL



A

- A-PRIMER, PERCUSSION, 21-GRAIN, MK.2A1
- B-PRIMER, COMBINATION ELECTRIC AND PERCUSSION, MK.XV-MOD.1
- C-PRIMER, FRICTION, M 1914
- D-PRIMER, ELECTRIC, M 30
- E-PRIMER, PERCUSSION, 100-GRAIN, MIBIAI
- F-PRIMER, PERCUSSION, M22A2



B



C



D



E



F

RA PD 4314

FIGURE 36.—Artillery primers.

AMMUNITION, GENERAL

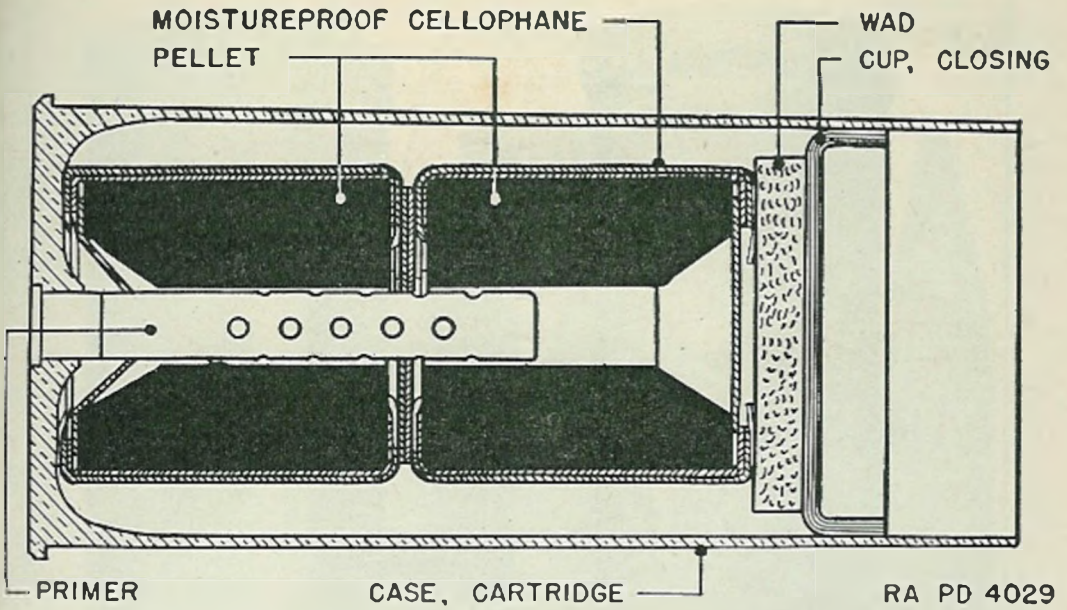

FIGURE 37.—Double pellet blank ammunition.

AMMUNITION DATA TAG

Pioatinnny Arsenal, N. J. 1940

Contract No. Ord. 2477 P. A. E. O. 1061

1 Charge Propelling, M2 (White Bag) for 155 mm., Howitzer, M1917, M1917A1 and M1918.

P. A. FNH Smokeless Powder, M3, P. A. Lot X-3946 of 1939. Net Wt. 7 Lbs. 15.8 Ounces.

Weighed by: \_\_\_\_\_ Checked by: \_\_\_\_\_

Igniter: Army Black Powder, Herc. 1st 27, Grade A-1

Weight: 3 Ounces 1.5 Ounces in each end of Base Zone section.

BALLISTIC DATA					
Zone	Wt. of Chg.		Wt. of Proj.	Muzzle Velocity	Pressure
	Lbs.	Ozs.	(Lbs.)	(Ft./Sec.)	(Lbs./Sq. In.)
5.	5	7.4	95	1082	
6	7	3.6	95	1357	
7	7	15.8	95	1476	28,790

REMOVE TAG BEFORE FIRING

Certified to by: A. ELY, Inspector

FIGURE 38.—Propelling charge data tag.

RA PD 4013

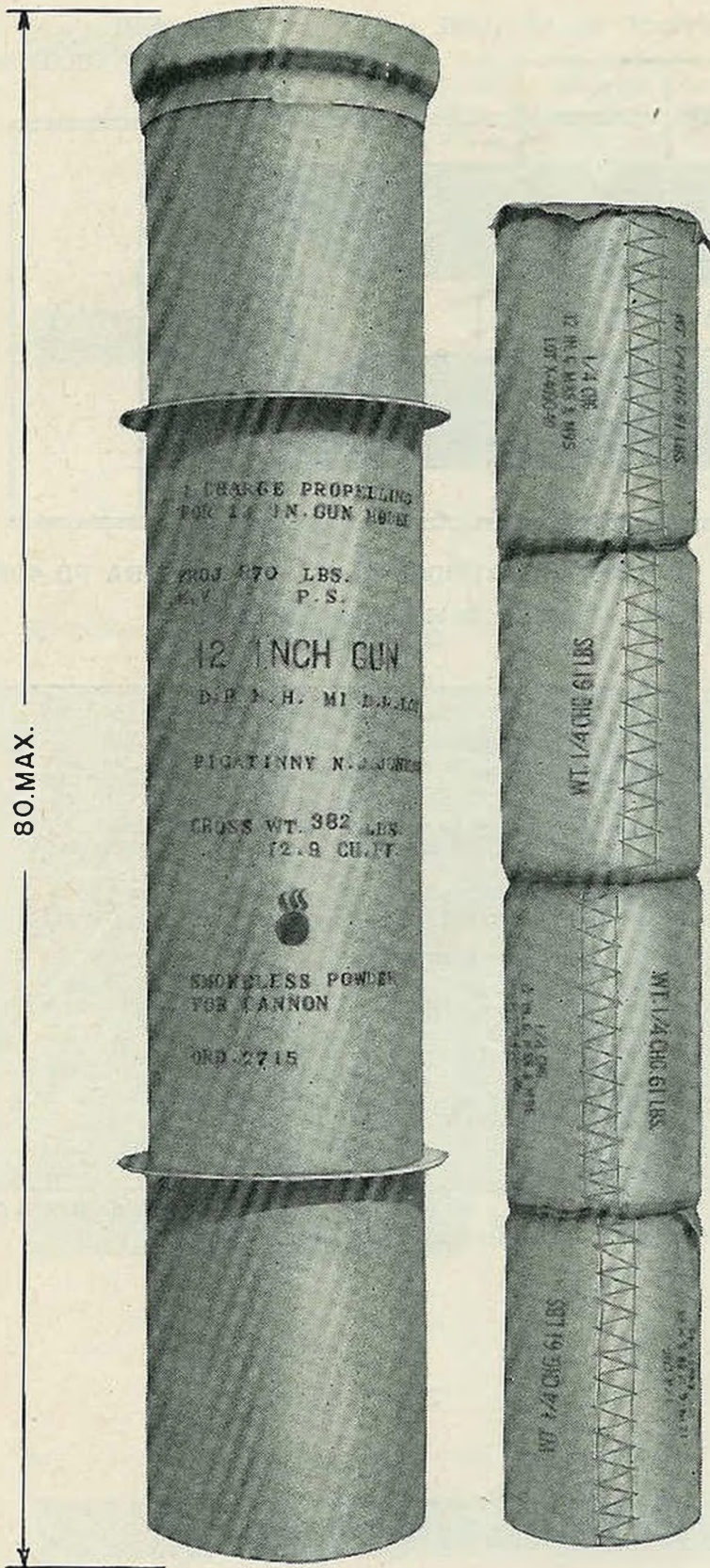

FIGURE 39.—Cartridge storage case and charge. RA PD 4315

AMMUNITION, GENERAL

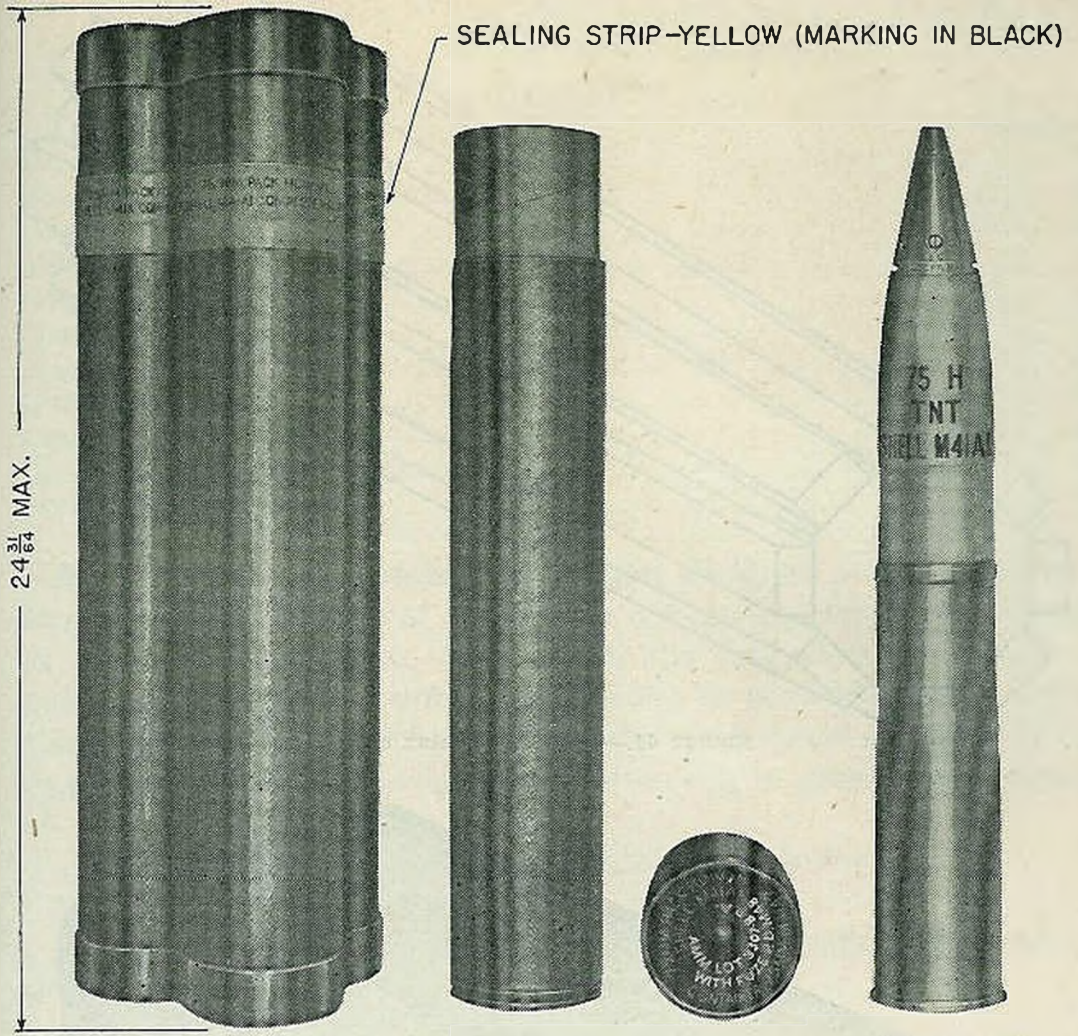
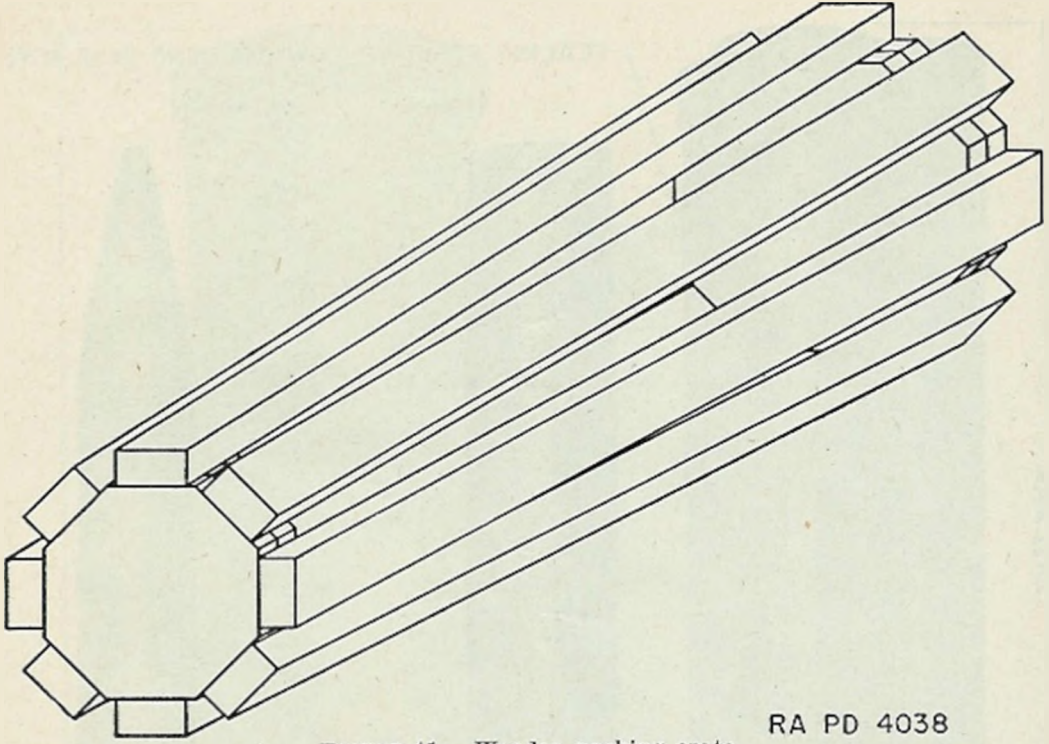

FIGURE 40.—Bundle packing.

RA PD 4316

AMMUNITION, GENERAL



RA PD 4038

FIGURE 41.—Wooden packing crate.

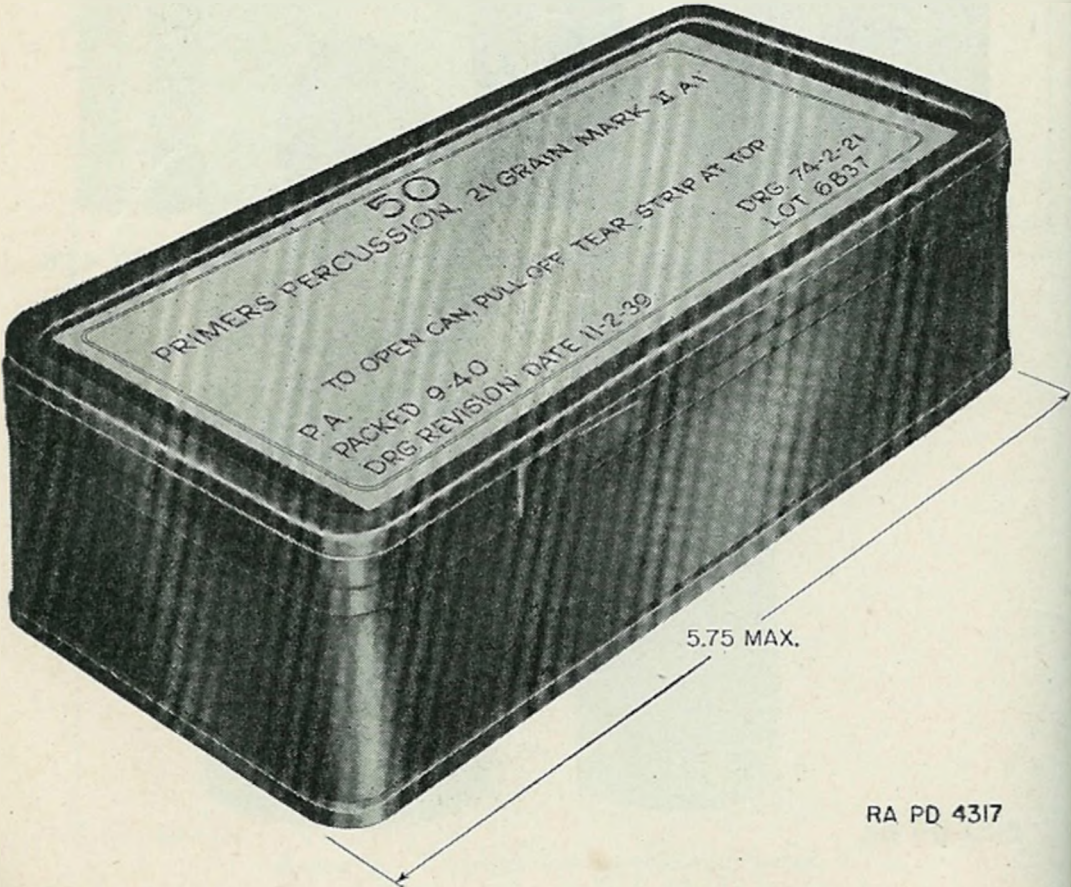

RA PD 4317

FIGURE 42.—Primer packing can.

## SECTION VI

## BOMBS

	Paragraph
General .....	88
Classification and identification .....	89
Demolition bombs .....	90
Armor-piercing bombs .....	91
Fragmentation bombs .....	92
Chemical bombs .....	93
Practice bombs .....	94
Drill bombs .....	95
Fuzes .....	96
Care and precautions in handling .....	97
Packing and marking .....	98

**88. General.**—*a.* Bombs are missiles designed for release from airplanes. For reasons of safety they are usually stored and shipped as separate components. For use in the field they are issued as unassembled complete rounds which must be assembled prior to use. (See also par. 98 and ch. 3.) While the components of bombs differ, depending on the particular type and model, in general they consist of—

- (1) The unfuzed bomb, with or without fin assembly.
- (2) The fuze or fuzes.
- (3) The fin assembly (for smaller bombs, assembled to bomb as shipped).
- (4) The arming wire assembly.

These components for a complete round demolition bomb are shown in figure 45.

*b.* Bombs are installed in airplanes by means of suspension lugs on the side or tail of the bomb. Bombs of 100 pounds and heavier have two suspension lugs on the side of the body arranged for horizontal suspension of the bomb. Smaller bombs have one lug on the side and another on the tail end, thereby permitting the bomb to be installed either in a horizontal or vertical bomb rack.

*c.* The functioning of bombs is dependent primarily upon the action of the fuze fitted thereto—superquick, delay, or time. The terms superquick and delay are used in reference to the action at the instant of impact, whereas time refers to time after release.

*d.* Bomb fuzes are prevented from arming or functioning by means of an arming wire which is normally removed by the bomb's release from the airplane. When it is necessary to remove the arming wire to unfuze a bomb, instructions attached to the fuze will be carefully followed. Provision is made for releasing the bomb from the air-

plane without removing the arming wire from the fuze when it is desired that the bomb should land without functioning.

*e.* A brief description of the several types of bombs is included in the following paragraphs. For complete details of the various types and models, see TM 9-1980.

**89. Classification and identification.**—*a.* Depending upon the kind of filler, bombs may be classified according to purpose as demolition, fragmentation, or practice. Practice bombs are provided for training and marksmanship; they may have a low explosive spotting charge or they may be inert. Drill bombs, which are inert, provide for training and assembling (fuzing) and handling the complete round.

*b.* Bombs, in common with other types of ammunition, are identified by the painting, marking, and the accompanying ammunition data card. With one exception, the same basic color scheme which identifies all ammunition as to kind of filler (par. 8) is used for bombs. The marking on the bomb identifies it as to type, weight, model, filler, lot number, loading plant, and date loaded. Representative markings are shown in figures 47 and 48.

**90. Demolition bombs.**—*a.* These bombs are designed for the destruction or demolition of matériel targets, the destructive effect being produced chiefly by the violence of the detonation, although fragments may cause additional damage, particularly when the detonation occurs above ground. The walls of such bombs are relatively thin and the explosive filler is almost 50 percent of the total weight of the bomb. A blast effect is obtained by using a fuze designed for superquick action; a mining effect, by a delay action fuze. Standard demolition bombs are made in sizes ranging from 100 to 4,000 pounds and are designed to use both nose and tail fuze (fig. 43). Except for the 100-pound size, the fins are shipped separately (fig. 47). The bodies of demolition bombs of current design are cylindrical; those of earlier design were streamlined. Figure 44 shows a typical demolition bomb as a complete round; figure 45 shows the bomb as shipped but with packings removed; figure 46 shows the packing crate.

*b.* General purpose bombs are demolition bombs modified for use by all arms and services.

**91. Armor-piercing bombs.**—These are designed for piercing the armor of warships and other similarly armored targets and concrete protective targets. They are of heavier construction than demolition bombs and contain a relatively smaller percentage of explosive filler. They are designed for tail fuzes of the time delay type.



**92. Fragmentation bombs.**—*a.* Fragmentation bombs are designed for use against personnel and light matériel targets such as motor transport and airplanes, the principal destructive effect being produced by fragments of the bomb body projected at high velocity, the fragments weighing 0.2 to 0.3 ounces each. Bombs weighing 20 to 30 pounds and having relatively thick walls produce the most effective fragments. The explosive filler weighs approximately 15 percent of the total weight of the bomb. Tail fins are used to stabilize the flight of all bombs except those used for special purposes such as low altitude bombing, in which case a parachute is used to retard the flight of the bomb until the airplane has cleared the danger area. Fragmentation bombs are designed for nose fuze only. Fragmentation bombs are packed as unassembled complete rounds in wooden boxes, metal crates, or bundle packings. Typical fragmentation bombs are shown in figure 48.

*b.* Small fragmentation and incendiary bombs are assembled in clusters (fig. 49) for more effective use and for ease in handling and dropping. Cluster adapters support the individual bombs and in turn are hung on the large size bomb racks. The cluster is dropped from the airplane as a unit. The arming wire acts to release the bombs from the adapter, either by mechanical means directly or by firing a cartridge which causes their release.

**93. Chemical bombs.**—Bombs containing chemical agents which produce a toxic or an irritating physiological effect, a screening smoke, an incendiary action, or any combination of these, are termed chemical bombs. They are known as gas, smoke, or incendiary, depending upon the principal effect. The force necessary to open the bomb body and properly disperse the chemical agent is provided by an explosive element called a burster. As the body need serve only as a container for the chemical agent, the walls are very thin and the proportion of filler to total weight is very large. Chemical bombs are authorized in 4-, 30-, and 100-pound sizes. Fuze action is superquick to prevent the waste of any of the charge by its being carried underground. Chemical bombs are packed finned, but without fuze and burster, in wooden boxes. A typical chemical bomb is shown in figure 50.

**94. Practice bombs.**—Practice bombs are provided for training in marksmanship. They may be sand loaded at point of use and they may contain a low explosive spotting charge which for some uses, such as against water targets, may be omitted. Such bombs are designed to simulate corresponding service bombs of the fragmentation and demolition types. A typical practice bomb, one which simulates the demolition type, is shown in figure 51.

**95. Drill bombs.**—Drill bombs are provided for training in assembling (fuzing) and handling operations. They are the same size and shape as standard demolition bombs, ranging in weight from 100 to 2,000 pounds. All components are inert.

**96. Fuzes.**—*a. Types.*—Bomb fuzes are classified according to method of arming as—

- (1) Arming-vane type.
- (2) Arming-vane type with mechanical delay.
- (3) Arming-pin type.
- (4) Arming-pin type with time delay.
- (5) Time.

*b. Location.*—Any of these types may be designed for use in the nose or the tail of the bomb.

**97. Care and precautions in handling.**—Bombs and components will be handled as specified in chapter 3. In addition, the following will be observed:

*a.* Primers and detonators will be handled with the greatest care at all times. Special care will be taken to see that primer-detonator and fuze cavities are free from all foreign material prior to assembling these components to a bomb.

*b.* Prior to assembling and handling service bombs, personnel should be trained in such drill and practice with drill bombs and inert components as will insure safe and proper assembly.

*c.* Due care will be exercised to see that the section of arming wire protruding beyond the fuze is smooth and straight, as kinks or burs may cause a hung bomb.

**98. Packing and marking.**—*a. Packing.*—(1) All bombs are shipped and stored unfuzed. The nose and tail fuze openings are closed with shipping plugs which will not be removed except when the bomb is being inspected or the complete round is being assembled.

(2) In general, bombs weighing 100 pounds or less are shipped as an unassembled complete round in one package. Bombs weighing 300 pounds or more are shipped in two packages; one, the loaded bomb body with shipping bands, the other containing the fin assembly and other components required for the round.

*b. Marking.*—(1) Wherever appropriate, the color scheme used for painting the bombs described in paragraphs 8 and 89 is used on the packing boxes or crates. All information for identification and directions for shipping are marked on containers for bombs and components and on the bomb bodies when no container is used.

(2) A list of all separate components required for the complete round is stenciled on the shipping container in which these components are ordinarily packed. It is usual, however, to store these

components separately and, when such is the case, the word **WITHOUT** is stenciled above the list of components on the shipping container. When the separate components are packed with their respective bomb or fin assembly for shipment, the word **WITHOUT** is painted out and a card, listing the components as packed, is inserted in the accessory tray, tube, or box.

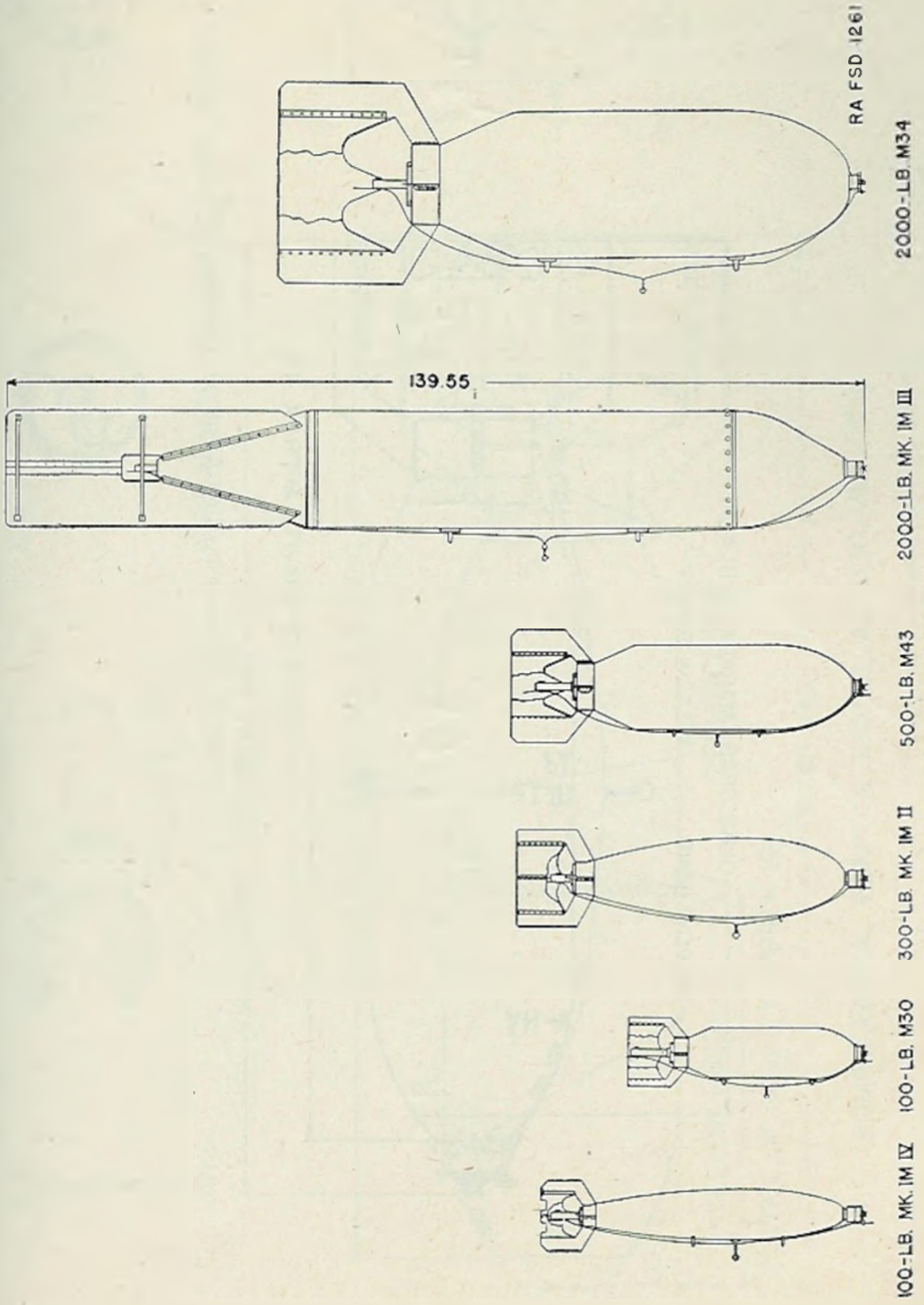
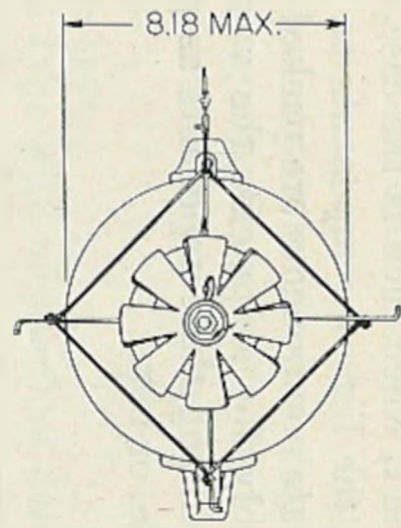
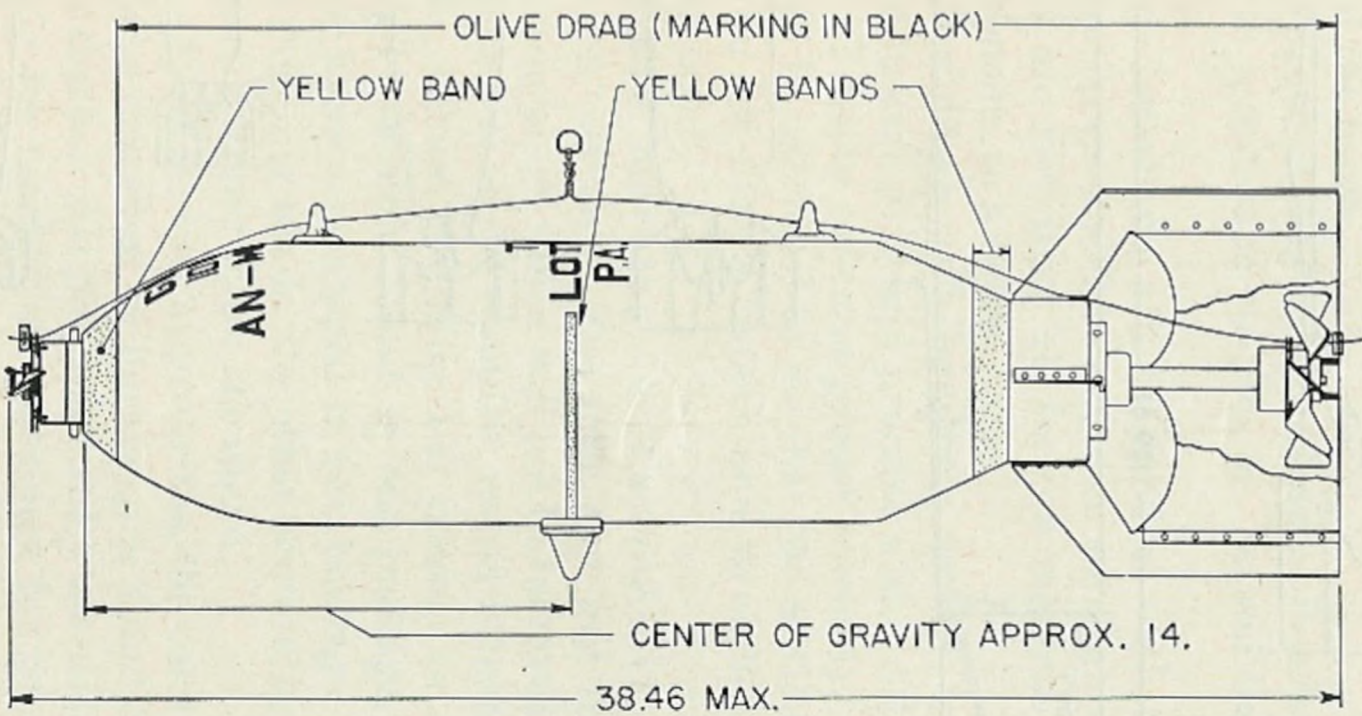

FIGURE 43.—Types of demolition bombs.



RA FSD 412A

FIGURE 44.—Bomb, demolition, 100-pound, complete round.



VANE

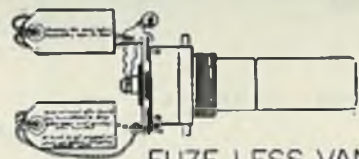

FUZE LESS VANE



WIRE, ARMING, ASSEMBLY

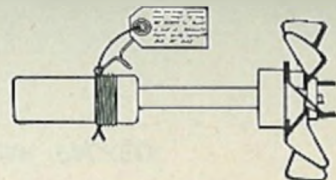

FUZE, BOMB, AN-MIOOAI (TAIL)

FUZE, BOMB, AN-MIO3 (NOSE)

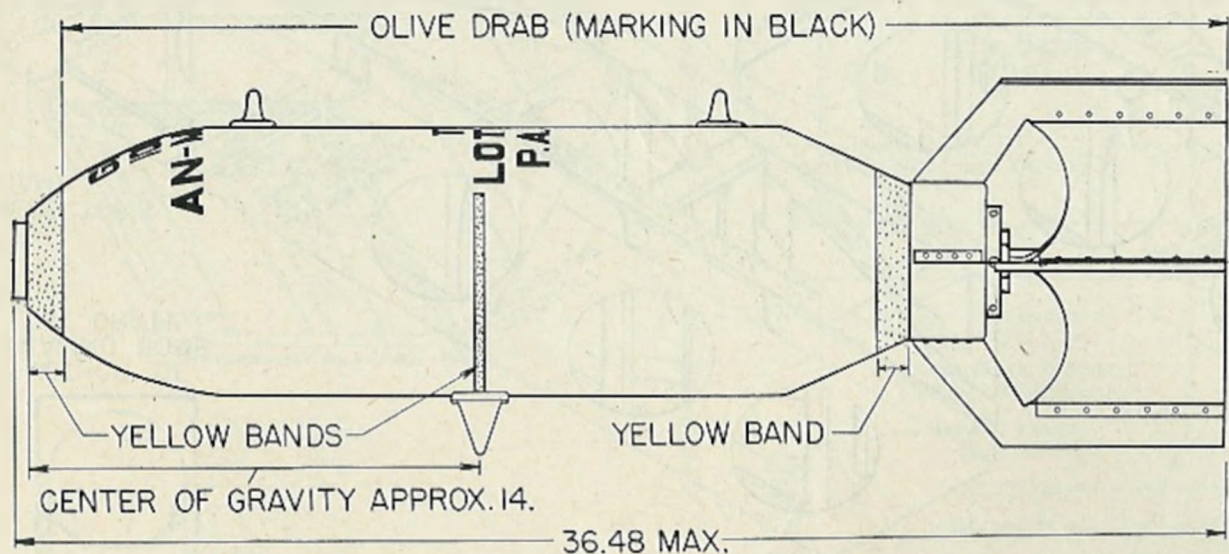

BOMB, GENERAL PURPOSE, 100-LB., AN-M30, UNFUZED

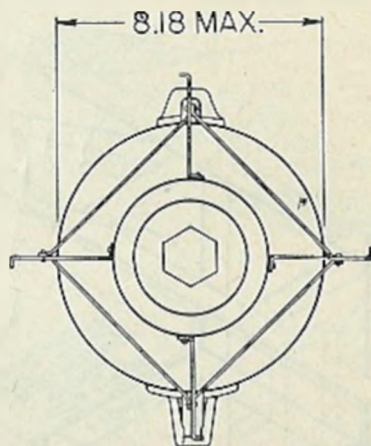

RA FSD 411A

FIGURE 45.—Bomb, demolition, 100-pound, components, complete round.

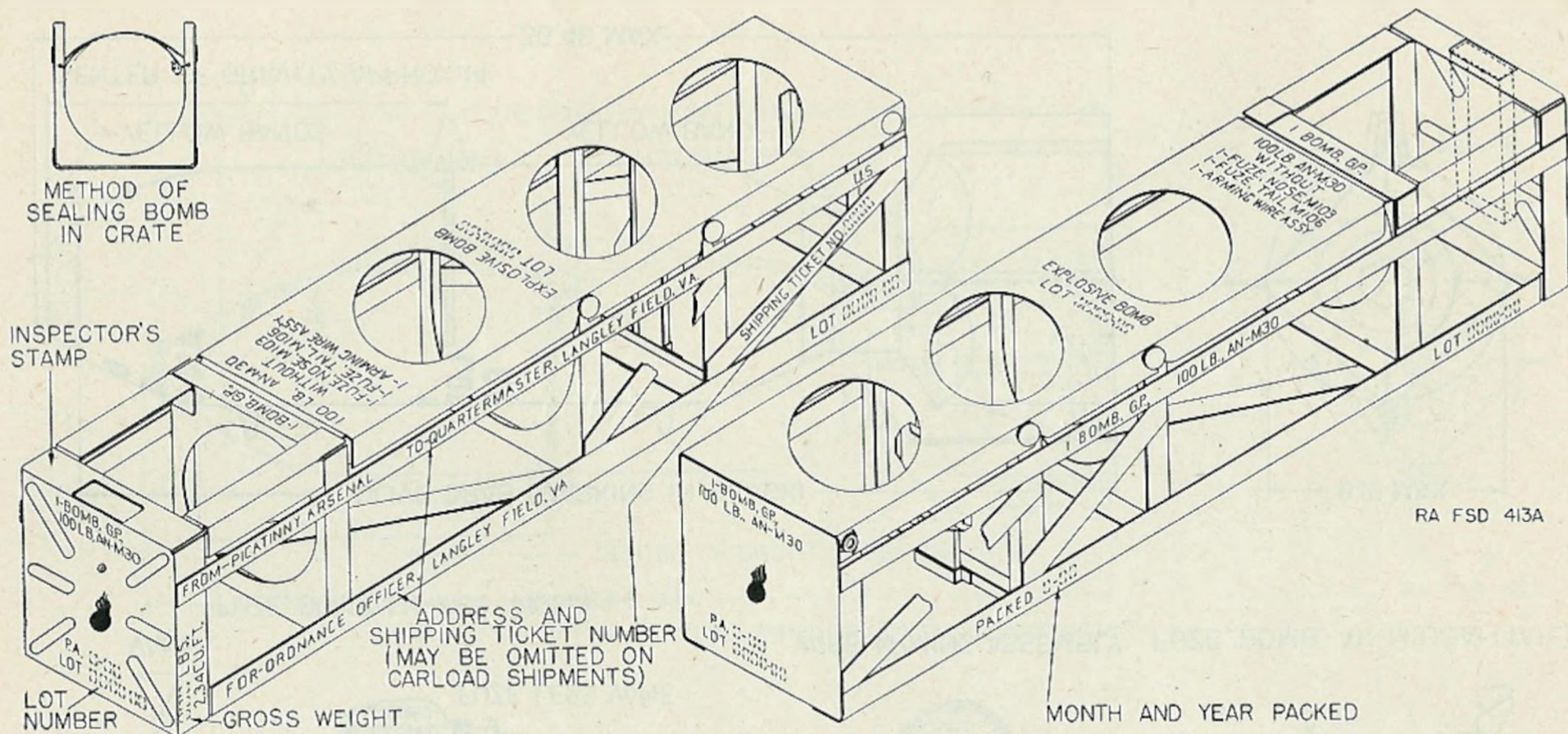

RA FSD 413A

FIGURE 46.—Bomb, demolition, packing and marking of crate.

AMMUNITION, GENERAL

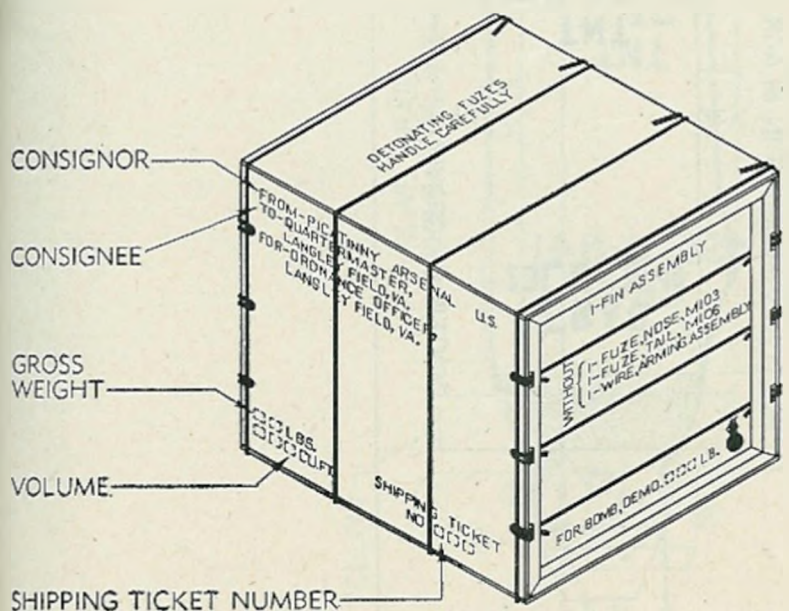
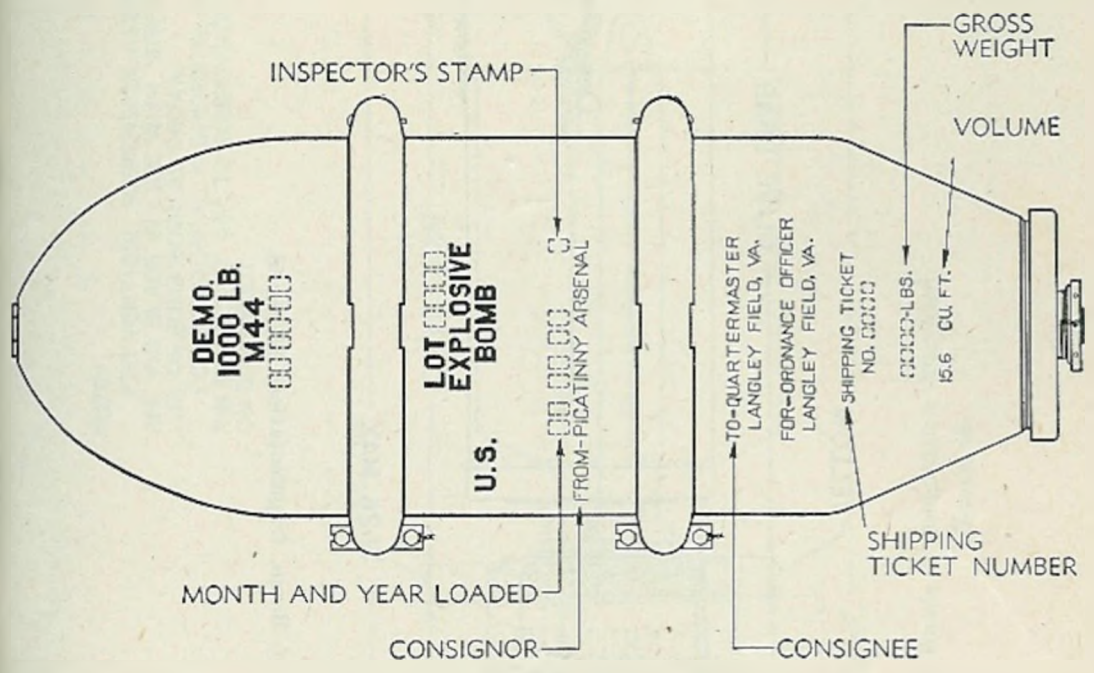
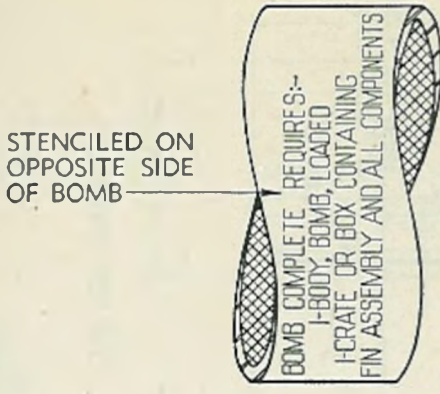

NOTE: CONSIGNOR, CONSIGNEE, AND SHIPPING TICKET NUMBER MAY BE OMITTED ON CAR-LOAD SHIPMENTS

FIGURE 47.—Bomb, demolition, 1,000-pound (as shipped).

RA PD 425A

84

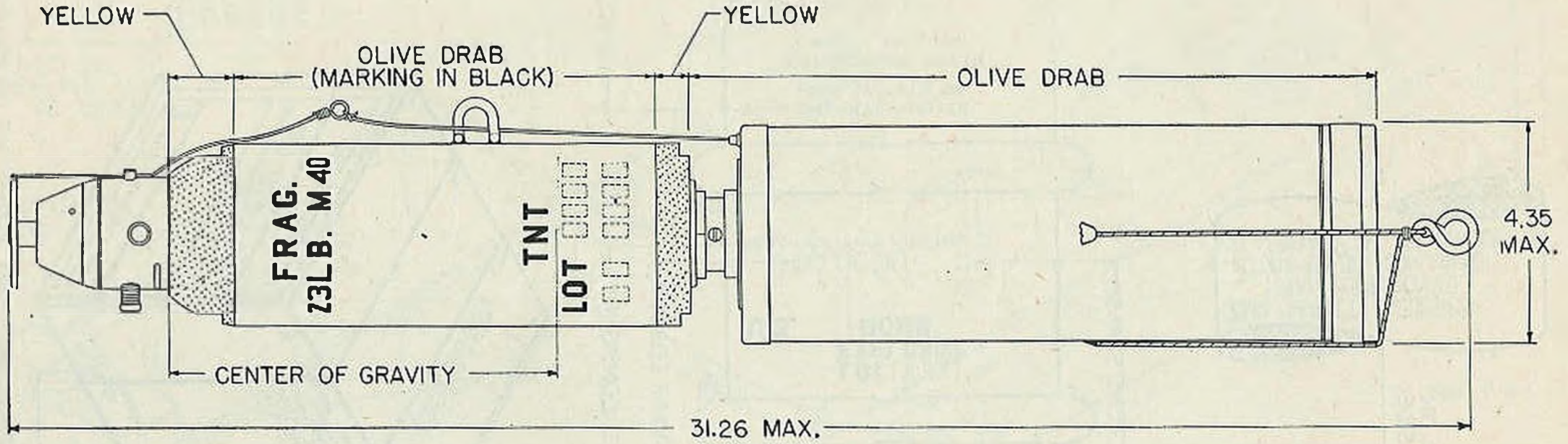

① Bomb, fragmentation, 23-pound.

RA FSD 997A



NOTE:

FOR VERTICAL SUSPENSION, ASSEMBLE ONE FIN BLADE IN LINE WITH SUSPENSION LUG, ON BOMB BODY AS SHOWN.

FOR HORIZONTAL SUSPENSION, ASSEMBLE FIN BLADES AT 45° TO SUSPENSION LUG ON BOMB BODY.

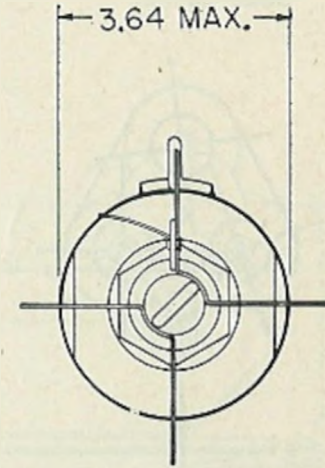
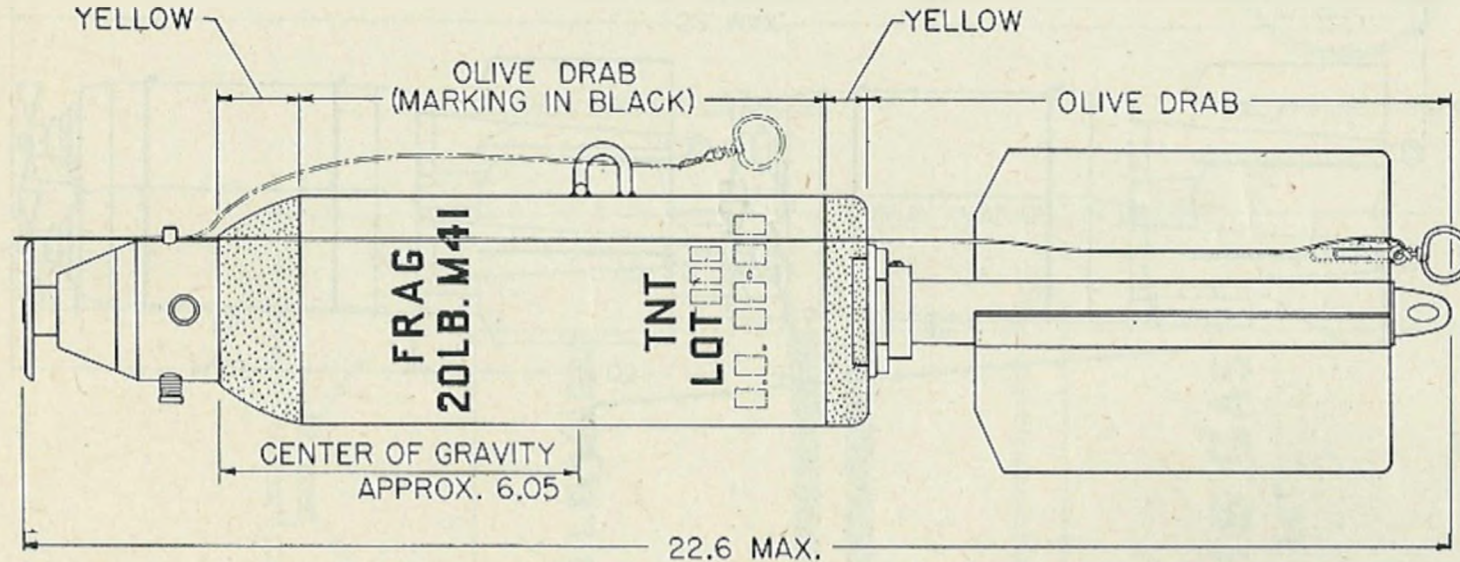

RA FSD 1018A

© Bomb, fragmentation, 20-pound.

FIGURE 48.

AMMUNITION, GENERAL

TIM 9-1900

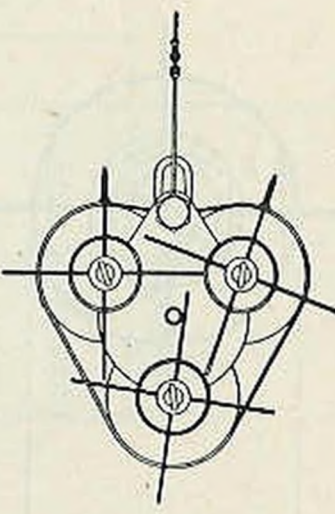
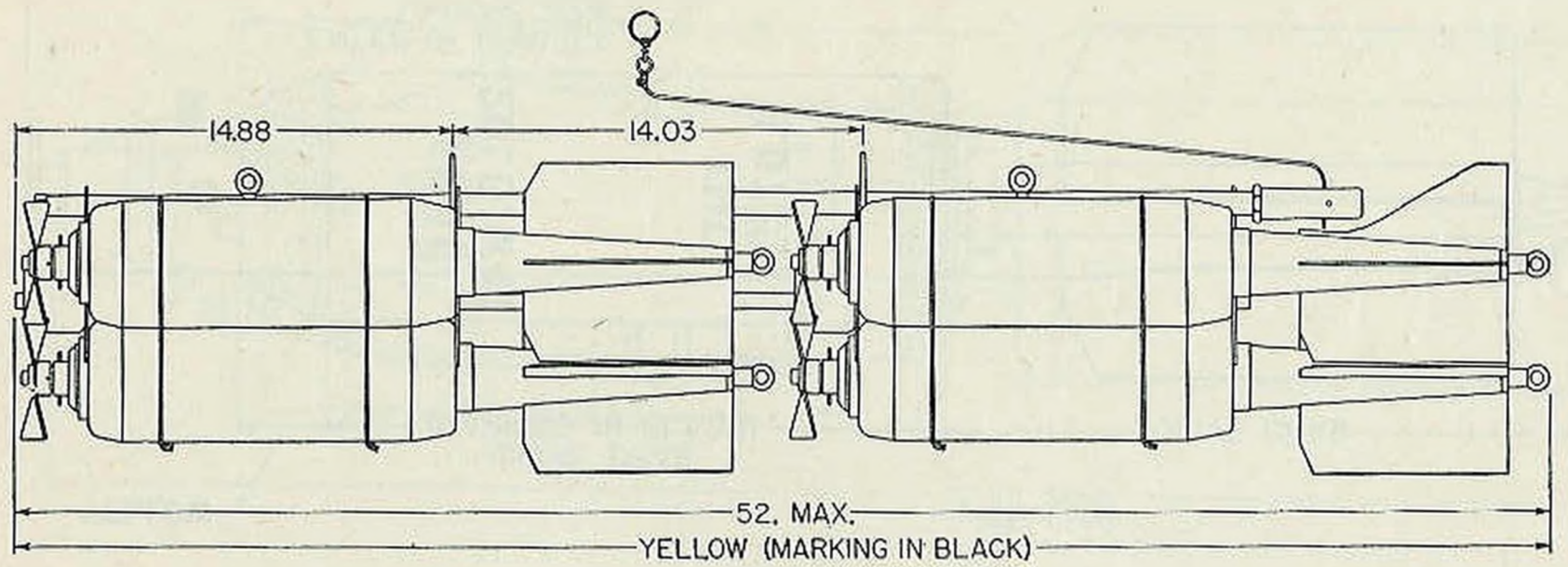

RA PD 5306

FIGURE 49.—Fragmentation bomb cluster.

BURSTER, ASSEMBLY, M3



FUZE, BOMB, MIOB (NOSE)

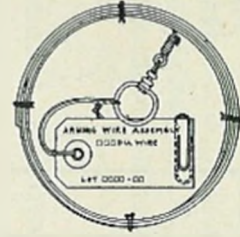

WIRE, ARMING, ASSEMBLY

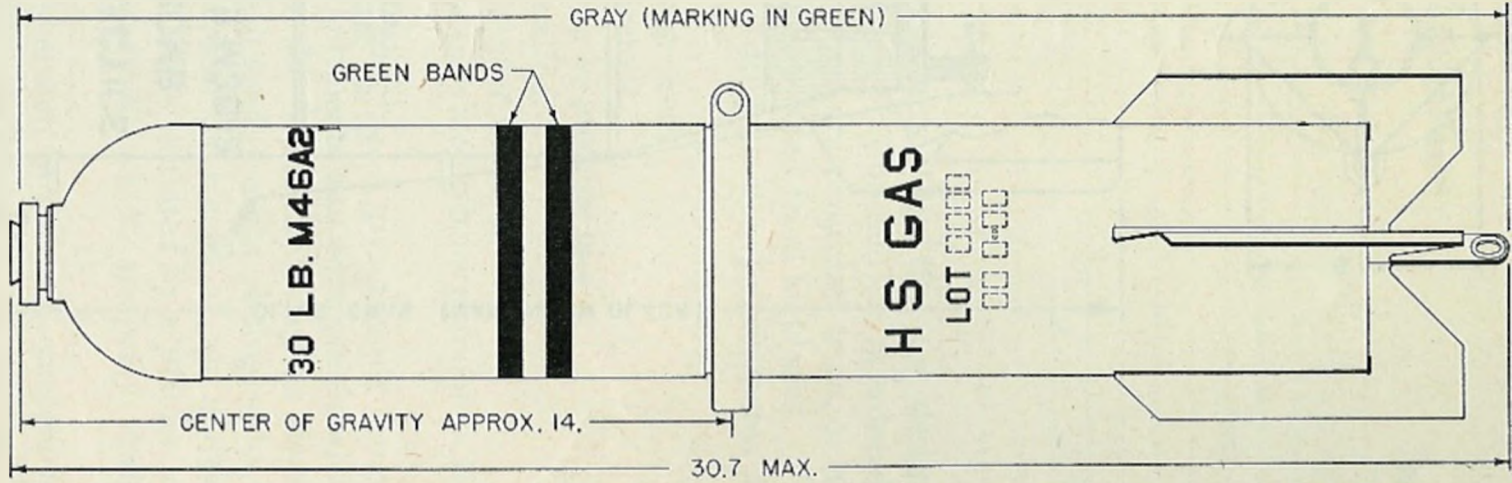

RA FSD 1006B

FIGURE 50.—Bomb, gas, persistent, HS, 30-pound.

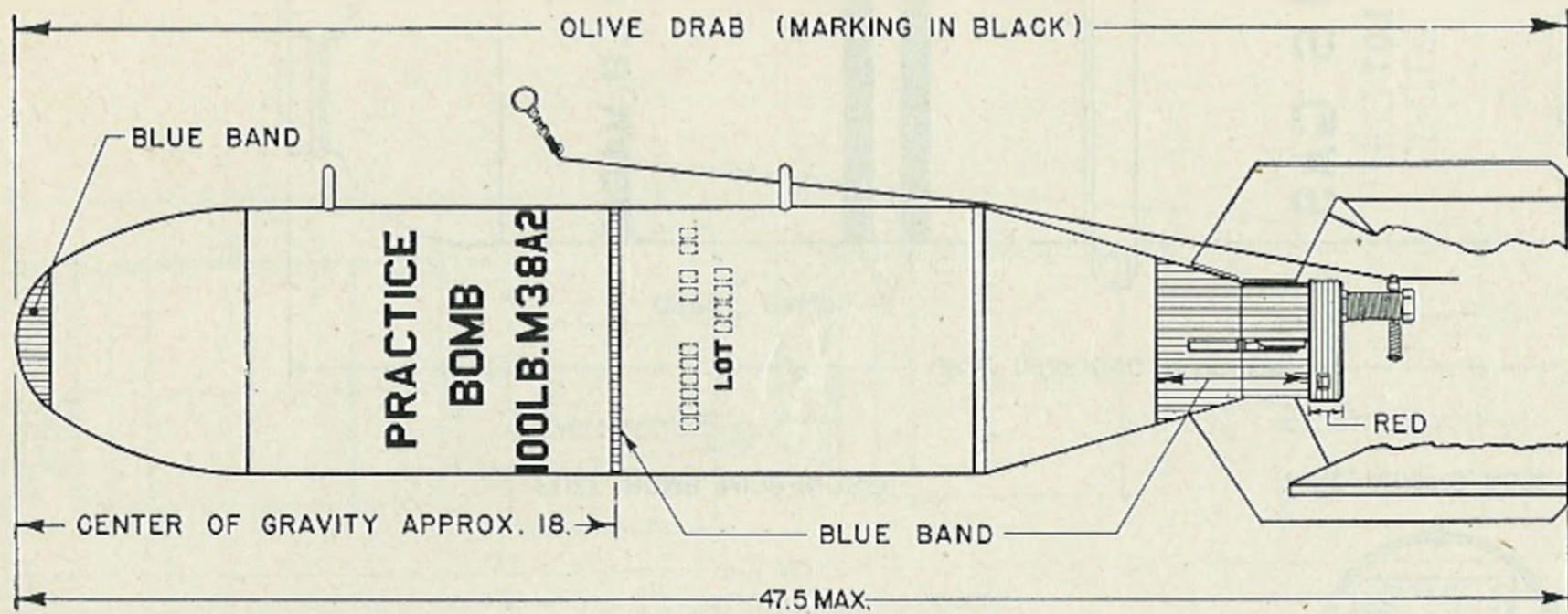
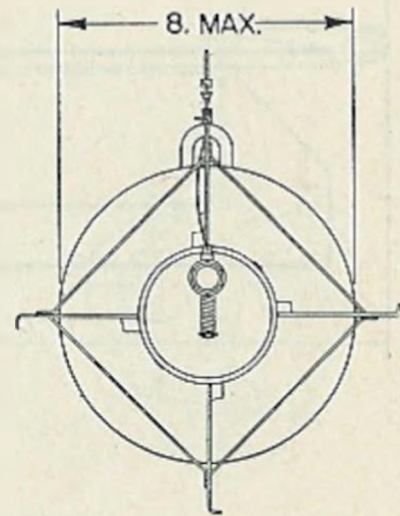

FIGURE 51.—Bomb, practice, 100-pound.



RA FSD 436A

## SECTION VII

## PYROTECHNICS

	Paragraph
General .....	99
Classification .....	100
Pyrotechnic compositions .....	101
Visibility of pyrotechnic signals .....	102
Flares .....	103
Photoflash bombs .....	104
Aircraft signals .....	105
Drift signals .....	106
Ground signals .....	107
Very signal lights .....	108
Care and precautions in handling .....	109
Packing and marking .....	110

**99. General.**—Military pyrotechnics (fig. 52) are designed to produce a brilliant light for purposes of illumination, or colored lights or smokes for signaling. Some types are projected from, or used on, the ground; others are released or projected from airplanes.

**100. Classification.**—*a.* According to use, pyrotechnics may be classified as—

Ground—for use from the ground.

Aircraft—for use from aircraft.

*b.* A further grouping according to purpose is—

Signals or lights—for signaling.

Flares or photoflash bombs—for illumination.

*c.* Any of the above types, when provided with a parachute, is known as a parachute type.

**101. Pyrotechnic compositions.**—*a.* A pyrotechnic composition is a physical mixture of chemical elements and compounds which produces illumination ranging from the “dark fire” used as elements of blinker signals to the brilliant flash used in night photography.

*b.* Pyrotechnics generally function by means of an igniter train analogous to the explosive train. It is initiated by a primer mixture, intensified by a “first-fire compound” which properly ignites the luminous candle.

*c.* Standard pyrotechnic composition, in general, consists of chlorates to provide oxygen for burning; aluminum or magnesium for fuel; barium, copper, and strontium salts for color; and a binding and waterproofing agent such as asphalt or paraffin.

**102. Visibility of pyrotechnic signals.**—While the distance at which pyrotechnic signals are visible and distinguishable varies with candlepower, color, and weather conditions, the following data may

serve as a basis for use. Probable distances at which signals are distinguishable under average weather conditions:

Type of signal	Approximate candlepower	Distinguishability (miles)	
		Day	Night
White star parachute.....	35,000	2.5	7 to 10
Red star cluster.....	18,000	} 0.6	2
Red star parachute.....	10,000		
Red chain parachute.....	1,500		

NOTE.—Signals may be visible, but not distinguishable, at greater distances. The visibility of colors in clear air is approximately as follows: green, 1; white, 1.1; amber, 1.4; red, 2.8.

103. Flares.—*a. General.*—Flares (fig. 52) are used for illumination of terrain during night operations involving reconnaissance, bombardment, photography, and landing.

*b. Reconnaissance flare.*—The flare, aircraft, parachute, M9, shown in figure 55, was developed to satisfy the requirement for a small parachute flare for reconnaissance work. It is fired from the pistol, pyrotechnic, M2, and functions approximately 2½ seconds after firing. The candle burns for one minute, producing a light of 60,000 candlepower.

*c. Night bombing flares.*—(1) The flare, aircraft, parachute, M24, shown in figure 58, is used for night bombing. It is a parachute type provided with shade to protect the bombardier from the glare of the burning candle. The candle burns for 3½ minutes, producing a yellowish light of 800,000 candlepower. The flare is designed for installation in standard horizontal bomb racks, and may be released either “armed” or “safe.” If released “safe,” the flare may function on impact. When released “armed,” the flare becomes fully ignited 5 seconds after release.

(2) The flare, aircraft, parachute, M26, shown in figure 56, is stabilized with fins and fitted with a mechanical time fuze adjustable for settings from 15 to 90 seconds. It is designed to function at a predetermined time after release, depending upon the setting of the time fuze. Functioning of the fuze projects the candle, shade, and parachute from the case. The candle ignites when the parachute opens, and burns for 3½ minutes, producing approximately 800,000 candlepower. It contains an asbestos shade which supports the flare and shields the bombardier from the glare. It is designed for night bombardment and may be installed only in a horizontal rack in the airplane. It may be released either “armed” or “safe”; if released “safe,” the flare may function on impact.

*d. Emergency landing flare.*—The flare, aircraft, parachute, M8A1, shown in figure 53, is intended for use in emergency landing. The flare furnishes a yellowish-white light of approximately 350,000 candlepower, and burns for approximately 3 minutes. It is designed for installation in either a vertical or horizontal rack in the airplane, and may be released either “armed” or “safe.” If released “safe,” the flare may function on impact. When released armed, the flare becomes fully ignited approximately 5 seconds after release.

*e. Airport flare.*—The flare, airport, M13, illustrated in figure 54, is designed for lighting airfields in emergencies, should the floodlighting system fail. It is ignited by means of a quick pull on the lanyard. The flare produces illumination in excess of 40,000 candlepower for 3 minutes.

**104. Photoflash bombs.**—The bomb, photoflash, M23, illustrated in figure 57, is designed to produce a brilliant light of short duration for night photography. It is equipped for installation in aircraft in standard horizontal or vertical flare racks. It functions approximately 15 seconds after release to produce a flash of 150,000,000 candlepower for 0.16 second. It may be dropped armed or safe but, if dropped safe, may function on impact.

**105. Aircraft signals.**—*a.* Aircraft signals and the pistol from which they are fired are illustrated in figure 59. The signal is contained in a signal case with an expelling charge. The signal case in turn is contained in a “barrel” with a propelling charge. When the pistol is fired, the propelling charge, in addition to projecting the signal case ignites a fuze. After 2.5 seconds the fuze ignites the expelling charge, which in turn expels the signal and ignites the pyrotechnic composition.

*b.* The signals currently authorized for use are—

- (1) Signal, aircraft, red star, parachute, M11.
- (2) Signal, aircraft, red star cluster, M14.
- (3) Signal, aircraft, white star, blinker, parachute, M15.
- (4) Signal, aircraft, green star, blinker, M16.
- (5) Signal, aircraft, double star, red-red, AN-M28.
- (6) Signal, aircraft, double star, yellow-yellow, AN-M29.
- (7) Signal, aircraft, double star, green-green, AN-M30.
- (8) Signal, aircraft, double star, red-yellow, AN-M31.
- (9) Signal, aircraft, double star, red-green, AN-M32.
- (10) Signal, aircraft, double star, green-yellow, AN-M33.
- (11) Signal, aircraft, single star, red, AN-M34.
- (12) Signal, aircraft, single star, green, AN-M36.
- (13) Signal, aircraft, single star, yellow, AN-M35.
- (14) Signal, aircraft, white star, parachute, M10 (limited standard).

*c.* Aircraft signals are identified by the color and marking on the identification top (outer wad).

106. Drift signals.—*a.* Drift signals are used as an aid in navigation for aircraft flying over water. They are small bomb-shaped signals with stabilizing fins. They are dropped by hand over the side of the airplane.

*b.* Signal, drift, M25 (fig. 62) is designed to function 3 seconds after impact with water. While floating, it emits a flame accompanied by a column of smoke. It is used for both day and night navigation.

*c.* Signal, drift, day, AN-Mk. 1, is a light paper shell filled with a metallic powder. It bursts upon impact with water and leaves a slick on the surface.

*d.* Signal, drift, night, AN-Mk. 4, functions after impact with water. While it floats, it burns out of the tail, emitting flame and some smoke.

107. Ground signals.—*a.* Ground signals are designed to be fired from the projector, pyrotechnic, M1A1, M3, or M4. The signals are equipped with tails and fin assemblies to provide stability in flight. They are fired from the projector, tail upward. They reverse at approximately 100 feet and rise to an altitude of approximately 600 feet before the signal is ignited and ejected from the case. The projector, pyrotechnic, M1A1, which is fired by use of a lanyard, is for use with the high burst ranging signal. The M3 and M4 projectors are fired by striking the projector smartly on the ground. This drives the signal primer against a fixed firing pin.

*b.* The signals currently authorized are as follows:

- (1) Signal, ground, amber star cluster, M22.
- (2) Signal, ground, amber star, parachute, M21.
- (3) Signal, ground, green star cluster, M20.
- (4) Signal, ground, green star, parachute, M19.
- (5) Signal, ground, white star cluster, M18.
- (6) Signal, ground, white star, parachute, M17.
- (7) Signal, ground, high burst ranging, M27.

*c.* Limited standard signals are—

- (1) Signal, ground, red chain, parachute, M7.
- (2) Signal, ground, red star cluster, M6.
- (3) Signal, ground, white star, parachute, M5.

*d.* Standard ground signals are identified by the color and marking on the fin. Limited standard ground signals are identified by the color and marking on the identification top (outer wad).

108. Very signal lights.—These are the plain cartridge type of ground signal fired from a pistol (fig. 61). They contain a primer, expelling charge, quick match, and illuminant charge. The color of the signal, red, white, or green, is indicated by the form and color of



the top wad of the cartridge. The signals burn for approximately 5 seconds.

**109. Care and precautions in handling.**—*a. Storage.*—Pyrotechnics should be protected against moisture. Containers which show signs of dampness or moisture will be carefully examined, and if there is any evidence of moisture on the pyrotechnics they will be destroyed. Pyrotechnics should be handled with care and protected against shock; the boxes should not be dropped or thrown. They should not be stored with other kinds of ammunition. Photoflash bombs which have become damaged in handling or storage should be destroyed in accordance with the provisions of chapter 4. They will not be disassembled under any circumstances.

*b. Flares.*—For information concerning the serviceable life of flares and disposition of overage flares, see OFSB 3-9.

*c. Toxicity.*—Pyrotechnic material is poisonous to men and animals if taken internally.

*d. Recoil.*—Both hands should be used to hold the pistol when discharging the flare, aircraft, parachute, M9, because of the powerful recoil.

*e. Fires.*—The incendiary effect of pyrotechnic material should be kept in mind in using such material in the vicinity of dry brush and grass.

*f. Duds.*—During maneuvers over terrain other than military reservations the location of dud flares and photoflash bombs will be observed. The duds will be sought out and destroyed as soon as possible.

**110. Packing and marking.**—*a. Packing.*—Pyrotechnics are packed in metal-lined or unlined, nailed or wire-bound wooden boxes. Those in unlined boxes are packed in inner containers consisting of sealed corrugated-board cartons, cylindrical fiber containers, or metal containers. The cartons are dipped in paraffin to protect the contents from moisture. The containers are labeled or marked to show the type or kind, lot number, quantity, and limiting date for use, if any.

*b. Painting and marking.*—Pyrotechnics are marked in such a way as to provide positive identification for all purposes. Each item is marked to show the type or kind, lot number, and limiting date for use, if any.

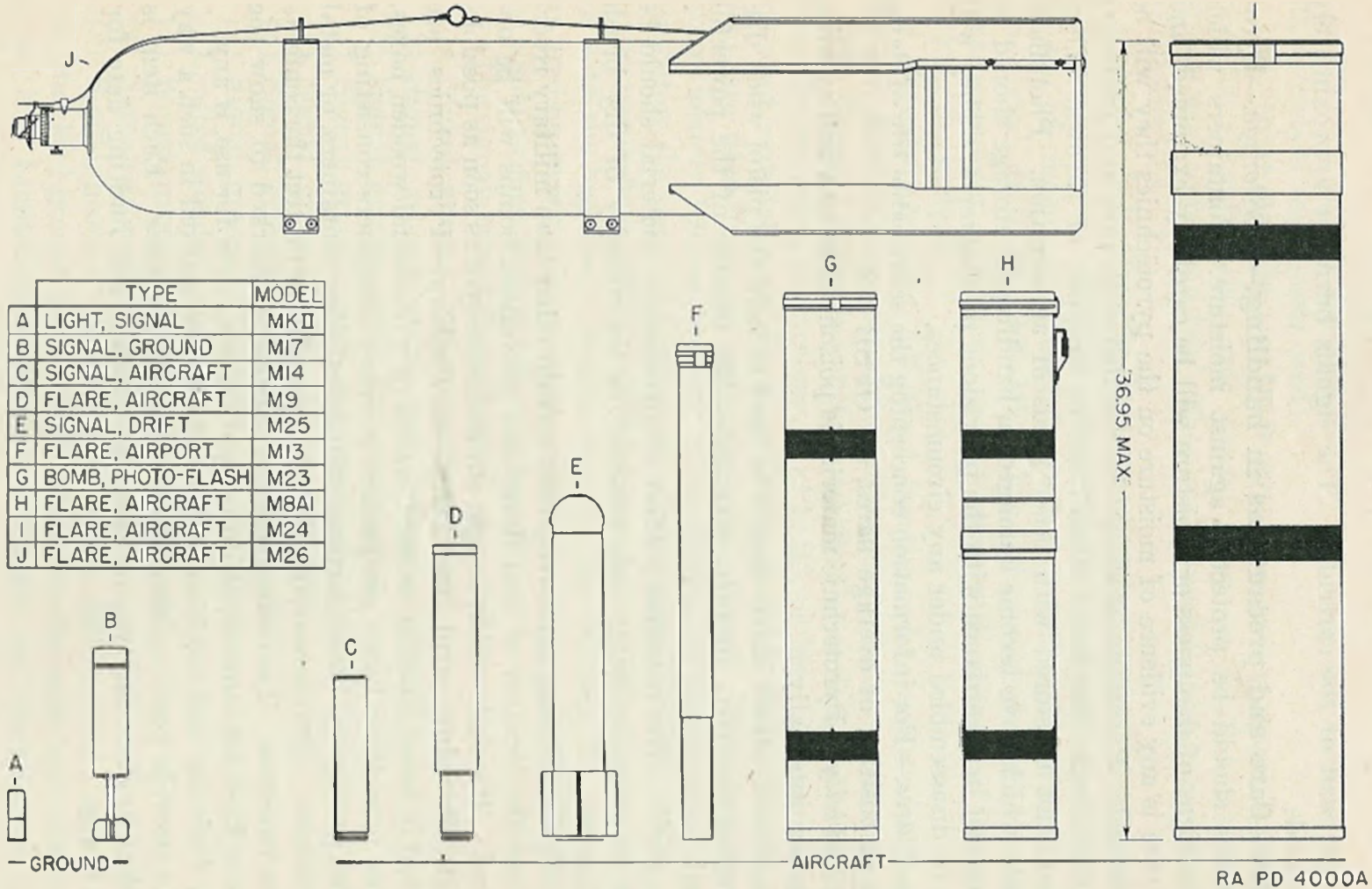

FIGURE 52.—Types of pyrotechnics.

AMMUNITION, GENERAL

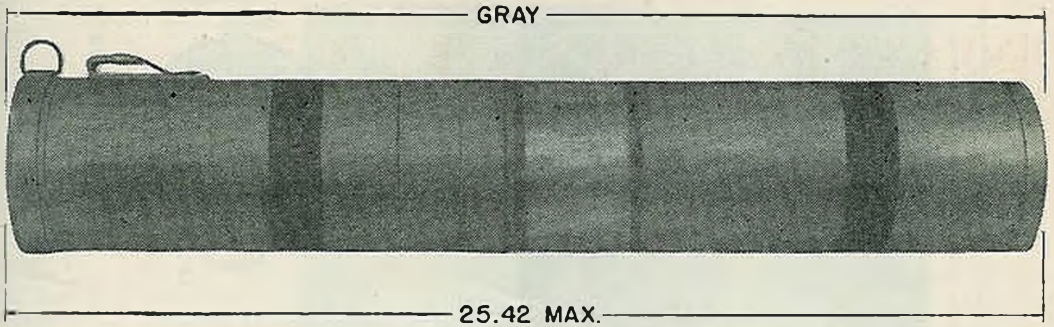

FIGURE 53.—Flare, aircraft, parachute, M8A1.

RA PD 4007

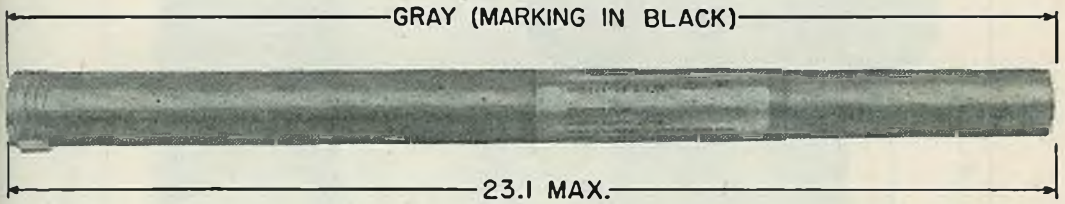

FIGURE 54.—Flare, airport, M13.

RA PD 4004A

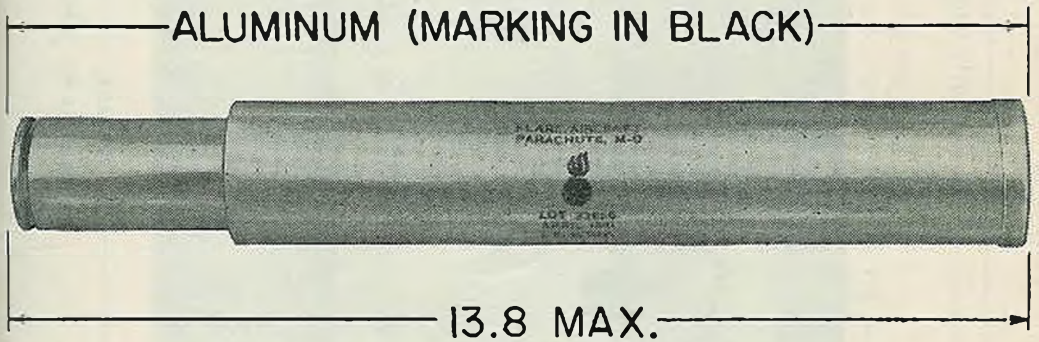
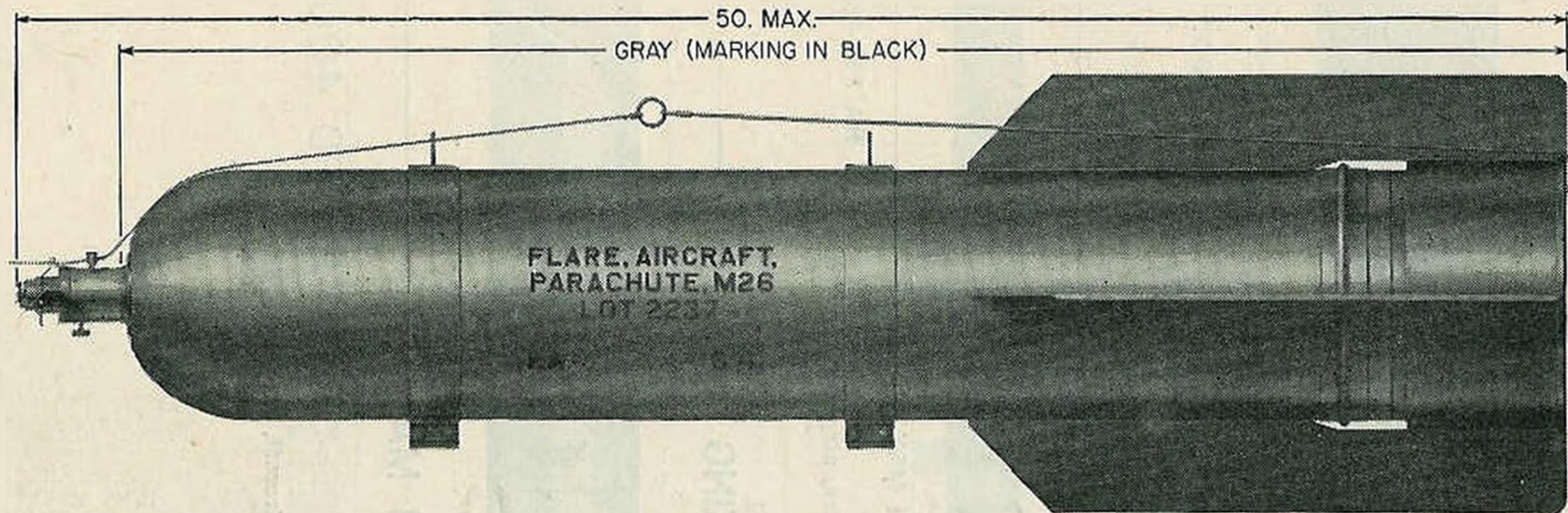

FIGURE 55.—Flare, aircraft, parachute, M9.

RA PD 4006A



RA PD 4504

FIGURE 56.—Flare, aircraft, parachute, M26.

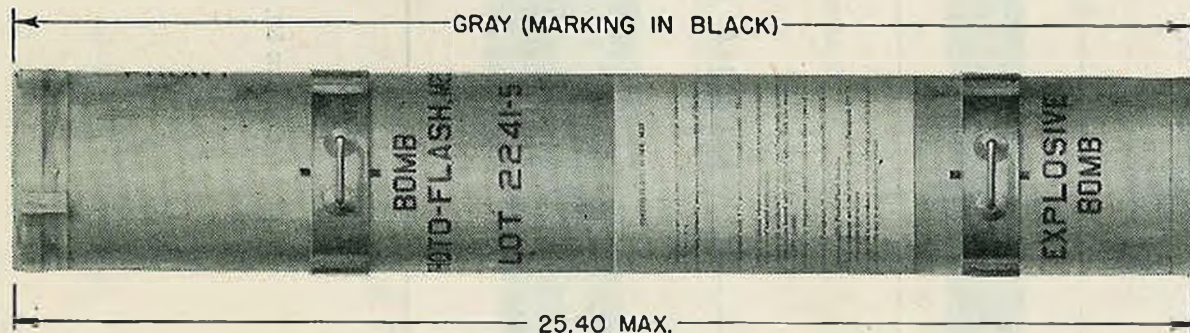

RA PD 3997A

FIGURE 57.—Bomb, photoflash, M23A1.

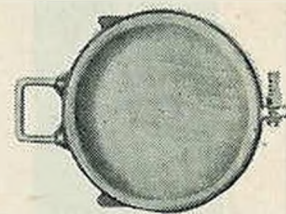

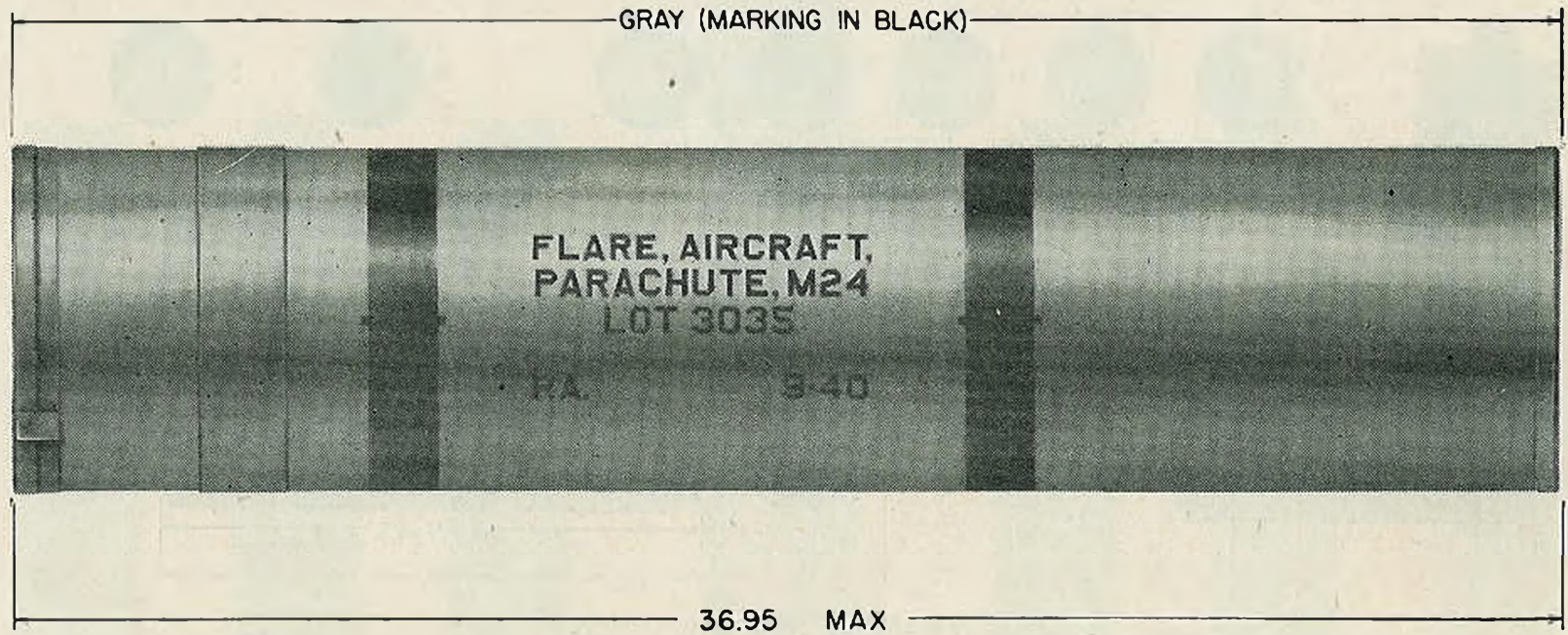

AMMUNITION, GENERAL

RA PD 4005A

FIGURE 58.—Flare, aircraft, parachute, M24.

<u>IDENTIFICATION TOP FOR:</u>	<u>COLOR</u>	<u>IDENTIFICATION TOP FOR:</u>	<u>COLOR</u>
<b>A</b> —SIGNAL, AIRCRAFT, PARACHUTE, RED STAR, M11	RED	<b>F</b> —SIGNAL, AIRCRAFT, DOUBLE-STAR, AN-M29	YELLOW-YELLOW
<b>B</b> —SIGNAL, AIRCRAFT, SINGLE-STAR, AN-M34	RED	<b>G</b> —SIGNAL, AIRCRAFT, DOUBLE-STAR, AN-M30	GREEN-GREEN
<b>C</b> —SIGNAL, AIRCRAFT, SINGLE-STAR, AN-M35	YELLOW	<b>H</b> —SIGNAL, AIRCRAFT, DOUBLE-STAR, AN-M31	RED-YELLOW
<b>D</b> —SIGNAL, AIRCRAFT, SINGLE-STAR, AN-M36	GREEN	<b>I</b> —SIGNAL, AIRCRAFT, DOUBLE-STAR, AN-M32	RED-GREEN
<b>E</b> —SIGNAL, AIRCRAFT, DOUBLE-STAR, AN-M28	RED-RED	<b>J</b> —SIGNAL, AIRCRAFT, DOUBLE-STAR, AN-M33	GREEN-YELLOW
<b>X</b> —ALUMINUM (MARKING IN BLACK)			

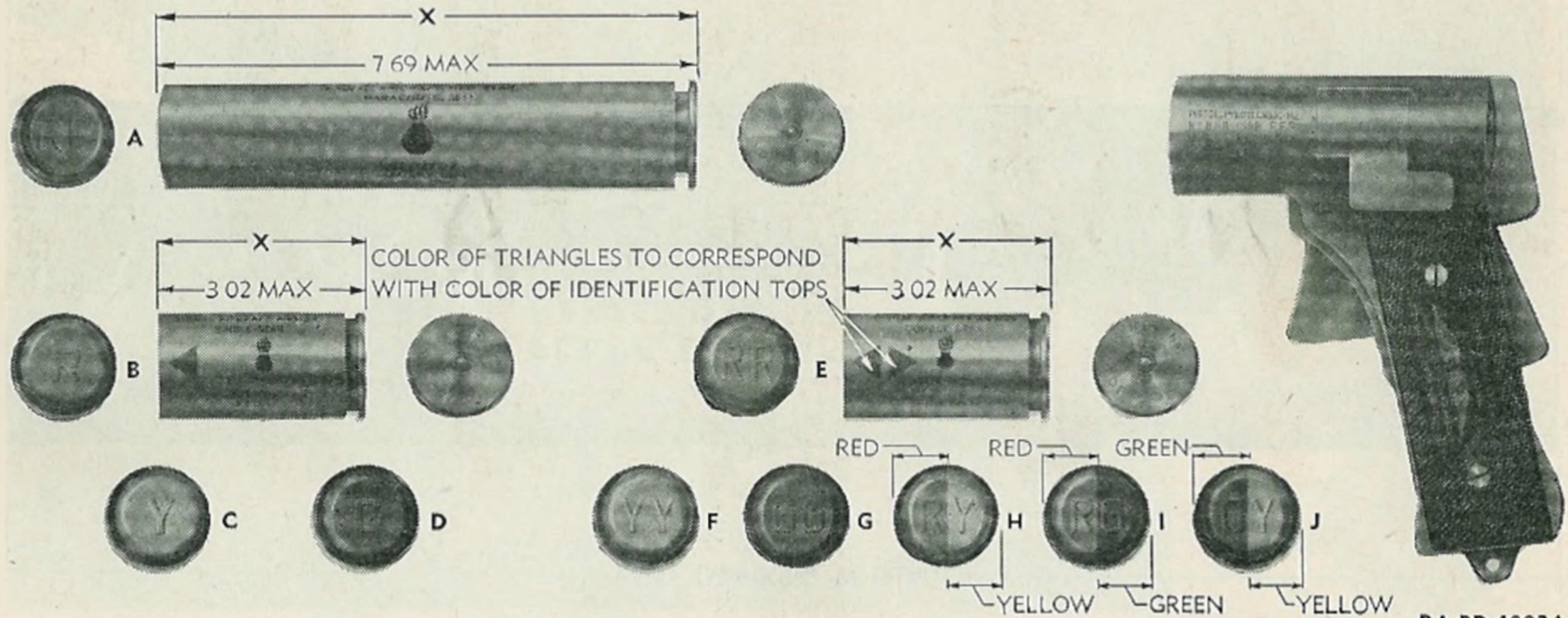

FIGURE 50.—Aircraft signals and pistol.

RA PD 4002A

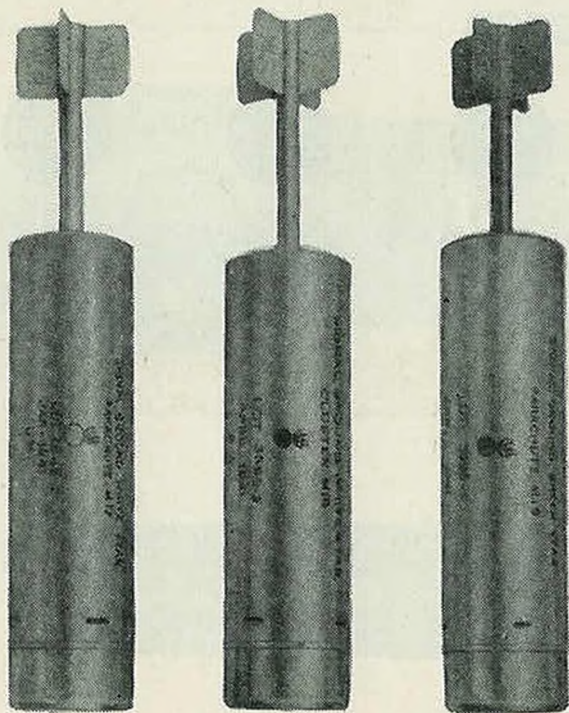
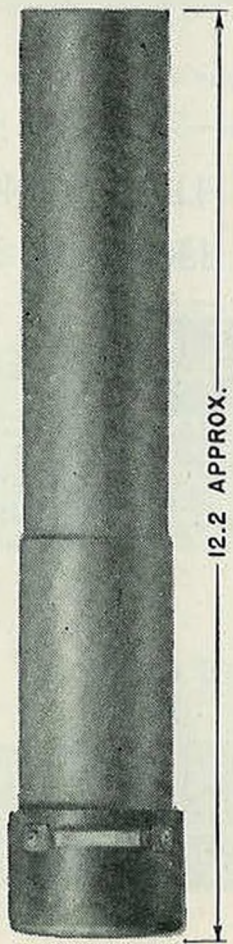
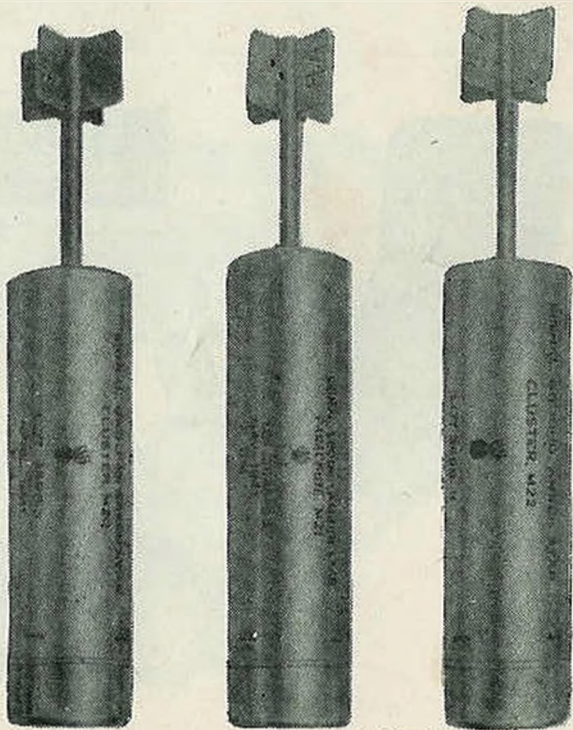

FIGURE 60.



12.2 APPROX.



RA PD 4001

AMMUNITION, GENERAL

**TW 9-1900**

-Ground signals and projector.



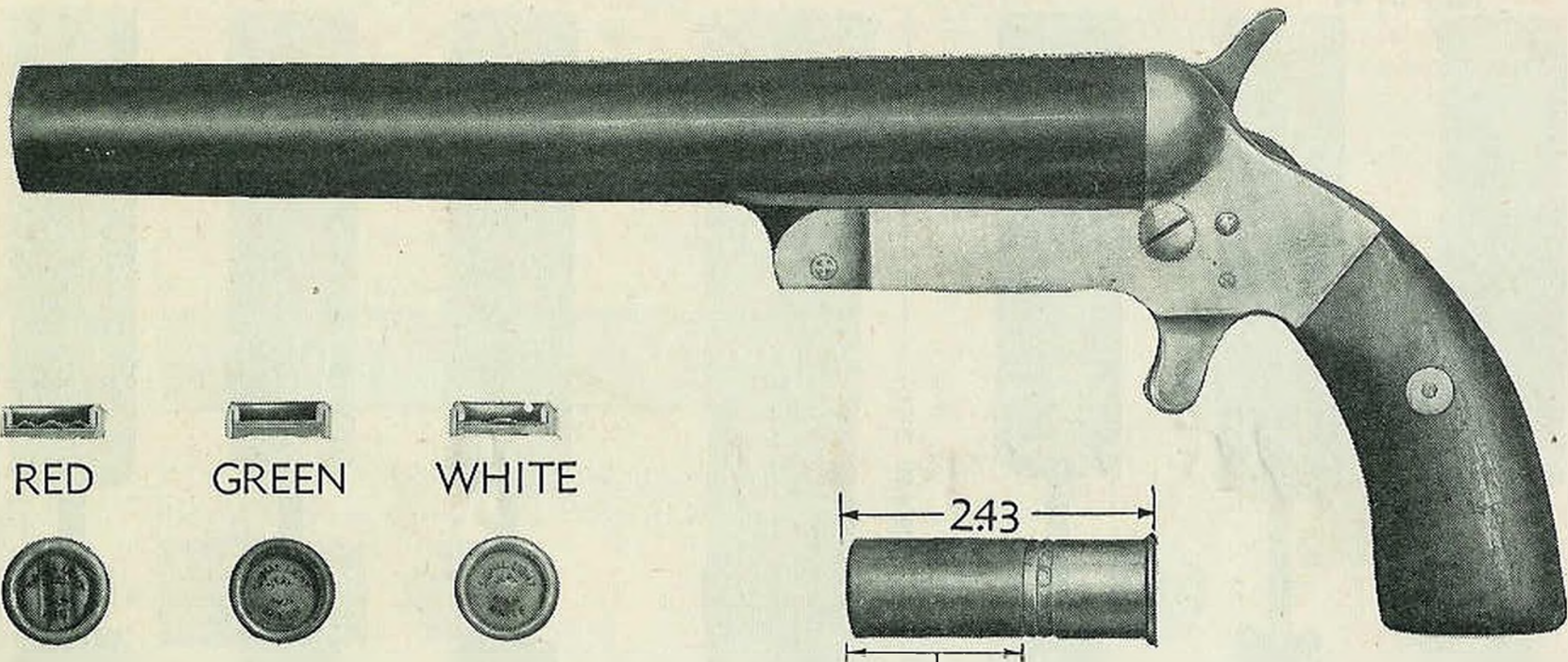

RED

GREEN

WHITE

243

COLOR OF WRAPPER  
CORRESPONDS WITH  
COLOR OF SIGNAL

RA PD 4003A

FIGURE 61.—Very signals and pistol.

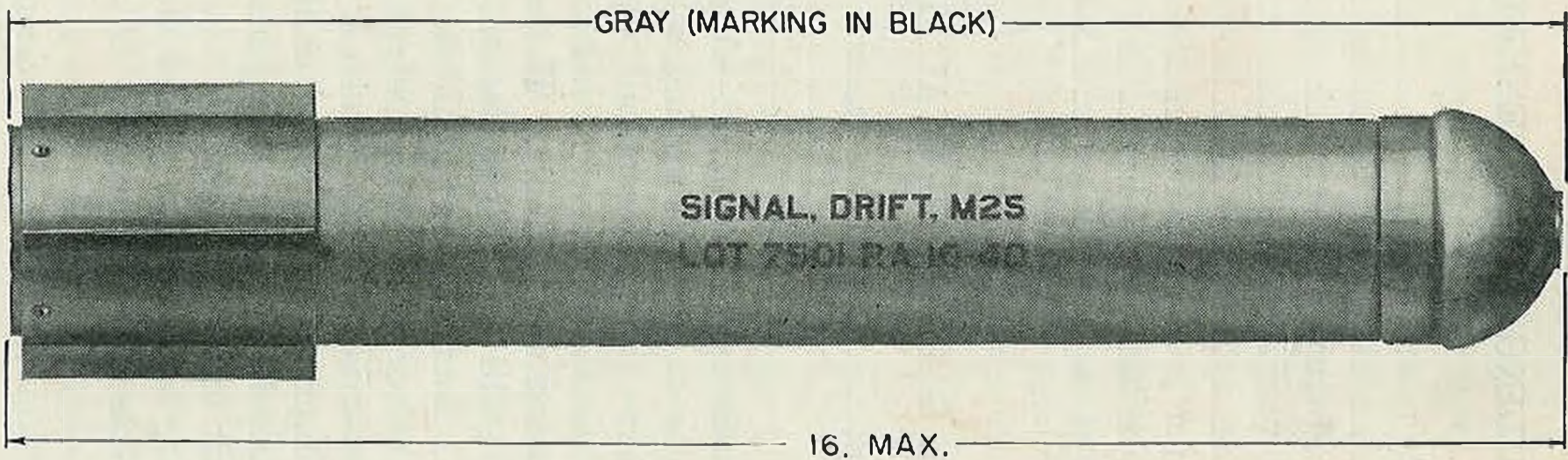

RA PD 4008A

FIGURE 62.—Signal, drift, M25.

## CHAPTER 3

### CARE, HANDLING, AND PRESERVATION

	Paragraphs
SECTION I. General safety precautions.....	111-113
II. Storage .....	114-118
III. Inspection and surveillance.....	119-132
IV. Packing and marking.....	133-139
V. Shipping .....	140-144
VI. Precautions for practice firing.....	145-153
VII. Ammunition in harbor defenses.....	154
VIII. Ammunition at supply points.....	155-157

#### SECTION I

#### GENERAL SAFETY PRECAUTIONS

	Paragraph
General precautions.....	111
Guard protection.....	112
Fire protection.....	113

111. **General precautions.**—*a. General.*—A study of accidents which have occurred in the handling, shipping, and storage of explosives and ammunition shows that, in practically every instance where the cause could be determined, the accident has been due to circumstances which may be classed as avoidable. Therefore, the following general safety precautions will be strictly enforced.

*b. For personnel.*—(1) Ammunition should be handled under the direct supervision of an officer or other competent person who understands thoroughly the hazards and risks involved. Persons handling ammunition should be impressed with the fact that their safety as well as that of others depends upon the intelligence and care exercised by themselves and by their fellow workers.

(2) Personnel handling ammunition should not be permitted to tamper with or disassemble any components. Serious accidents may result.

(3) Persons handling ammunition should clean all mud and grit from their shoes before entering the magazine, car, or boat in which there are explosives or ammunition.

*c. Safety shoes.*—Safety shoes should be worn whenever explosive dust is present, such as at black powder or high explosive loading operations. Safety shoes are shoes without exposed metal plates or nails and without insulating rubber soles.

*d. Handling ammunition.*—(1) Explosives and ammunition should be handled carefully. Bale hooks will not be used. Containers will not be tumbled, dragged, thrown, or dropped on each other or on the floor.

(2) All tools used when repairing, opening, or closing containers filled with hazardous explosives should be of nonferrous or nonspark-ing materials.

(3) Explosives and ammunition should not be exposed to moisture or dampness or to the direct rays of the sun for any long period. If it is necessary to leave boxes temporarily outside of magazines or cars, they should be covered with a tarpaulin which is so placed that air can circulate freely through the pile.

(4) Ammunition will not be reconditioned, renovated, or salvaged within the magazine area unless the sites, buildings, or cars in which work is being done are devoted exclusively to such work and are specifically approved by the commanding officer.

*e. Containers.*—If explosives spill or sift from a leaky container, all work will be stopped until the explosives have been swept up and removed and any remaining particles or dust have been neutralized with water.

*f. Fire precautions.*—(1) Matches or other flame-producing devices will not be permitted in any magazine or magazine area except by written permission from the commanding officer. When necessary, permits will be granted to carry safety matches. They will be carried in a closed metal receptacle.

(2) Smoking will be absolutely prohibited in any magazine or magazine area, or around cars, wagons, motor trucks, or boats in which there are explosives or ammunition.

(3) No portable lights other than approved electric lanterns and flashlights will be used in magazines or around explosives and ammunition in cars, wagons, motor trucks, or boats. Electric lanterns and flashlights approved by the Bureau of Mines or by Underwriters Laboratory for Class 1 Group D locations may be used in lieu of such items approved by the Chief of Ordnance.

(4) All electric light and power lines where authorized within buildings containing ammunition and explosives or explosive vapors will be installed in accordance with drawings and specifications approved by the Chief of Ordnance.

**112. Guard protection.**—*a.* Magazines and magazine areas in which there are explosives and ammunition should be adequately guarded at all times. Magazine areas should be protected by non-climbable fences and all entrances should be securely locked unless

guards are stationed at them. Special precautions should be taken to guard areas which are not protected by a suitable fence.

*b.* Guards and others in charge of explosives and ammunition will be thoroughly instructed as to the hazards due to fire and explosion and the safety precautions to be taken.

*c.* Guards should be instructed to make a prompt report of the following:

(1) Any unusual occurrence in or near a magazine area.

(2) Grass or forest fires in areas adjacent to the magazine area.

(3) Conditions which are or may become fire hazards, such as long grass, undergrowth, and other vegetation in the vicinity of magazines.

(4) Dangerous practices of personnel working in magazines or explosive areas, such as smoking, unauthorized use of fire equipment, and tampering with ammunition or electrical equipment.

(5) Unlocked magazine doors and shutters, defective telephone and electric wires, and openings in fences.

*d.* Hunters in the area adjacent to magazines who are discovered using firearms in a manner that may endanger military stores will be warned and, if necessary, reported.

*e.* Airplanes flying over an explosives area at an altitude of less than 500 feet will be observed for identification and reported.

*f.* Guards protecting explosives or ammunition will be instructed regarding the danger in firing in the direction of a magazine.

*g.* Guards will be instructed that their most important duty is to protect explosives and ammunition against fire. Alarms will be given with the greatest possible speed so as to start action instantly, as serious fires and explosions have been avoided by prompt action of fire-fighting forces. After giving the alarm, guards will exert every effort to hold the fire under control until the fire-fighting forces arrive, except that should a fire occur in a closed magazine, they will not attempt to enter the magazine.

**113. Fire protection.—***a. General.*—Many of the fires involving explosives and ammunition are preventable. It is the duty of all concerned in the handling of explosives and ammunition to study the causes of fires and thoroughly inform themselves of the safety precautions that must be taken to prevent them.

*b. Causes of fires.*—Fires in magazines and magazine areas in which explosives and ammunition are stored may be due to several causes, of which the following are the most common:

(1) Dry grass, leaves, and underbrush ignited by sparks from locomotives, by smoking, or the careless use of matches and camp fires.

(2) Deteriorated explosives and ammunition. Explosives and ammunition deteriorate in storage. Normally this deterioration oc-

curs at such a slow rate that most explosives and ammunition remain serviceable for many years. However, under unfavorable storage conditions, explosives and ammunition give off heat so fast that it cannot be dissipated, and it causes the explosive or ammunition to burst into flame. In certain cases where the explosive or ammunition is confined, an explosion or detonation may result.

(3) Repacking, renovation, and salvage operations not properly supervised and conducted in accordance with recognized safety standards. The most common sources of trouble are excessive quantities of powder and loose explosives, accumulation of waste paper, broken boxes, etc., and failure to provide the proper barricades and firebreaks necessary to prevent the spread of fire from one operation to another.

(4) Careless or untrained employees or other persons who violate regulations by smoking, building fires, or striking matches in forbidden areas and buildings, or who tamper with explosives or ammunition, particularly grenades or fuzes.

(5) Failure to understand and carefully observe the safety precautions prescribed in this manual for destroying explosives and ammunition. The most frequent source of trouble is flying fragments which cause grass fires or explode piles of explosives and ammunition awaiting destruction.

(6) Sparks that may be caused by striking iron or steel nails or metal containers with iron or steel tools, or by nails in shoes striking flint, pebbles, sand grains, or nails in the floor. Such sparks, small as they are, have often caused disastrous explosions of black powder or of the dust of other explosives which ignite easily, and are the basis of the requirements in certain places in this manual for tools of brass, copper, or other nonsparking materials; for cleaning mud and dirt from shoes before entering magazines; and for wearing safety shoes (shoes without exposed metal nails or plates).

(7) Static electricity. A considerable charge of electricity may accumulate on smokeless powder and upon the body of an operator during handling operations. When a person so charged approaches powder or explosives, a spark may jump between him and the powder or explosives and ignite them. Personnel engaged in handling operations should go occasionally to the door and touch a suitable ground to remove a possible charge.

(8) Failure to provide proper safeguards for heating appliances, such as torches and furnaces, used in making repairs to magazine roofs and magazines.

(9) Lightning strikes buildings, trees, or other objects in or near explosive areas.

(10) Electric transmission lines blown down or in contact with inflammable materials.

(11) Lack of a proper muffler, or the use of a muffler cut-out, on motor vehicles.

*c. Special fire-prevention rules.*—Fire prevention is of the utmost importance because of the difficulties encountered in controlling fires involving explosives and ammunition. The special precautions that should be taken to prevent fires are set forth below.

(1) The duties of guards, firemen, military personnel, and others will be so arranged that an adequate fire-fighting force will be available at all times.

(2) Fire drills and inspections will be carefully conducted to insure that fire-fighting forces understand their duties and that fire-fighting equipment functions dependably under actual working conditions. Hose not tested to working pressures frequently bursts when most needed.

(3) To combat grass or forest fires in or near the magazine areas, there will be maintained at suitable locations an adequate supply of gunny sacks, brooms, rakes, hoes, or other similar equipment. This equipment should be regularly inspected and protected against theft or unauthorized use.

(4) When explosives and ammunition are being handled or work is being done in the immediate vicinity of such stores, there should be present ready for immediate use two chemical or other type hand fire extinguishers. It is not required that these be permanently located in a magazine, although this should be done if practicable, but it is required that they be present when employees need them. Many serious fires have been avoided by the prompt use of hand fire extinguishers.

(5) Vegetation in the form of grass, undergrowth, weeds, etc., which is or may become a fire hazard, will be controlled by the use of chemical weed killer or by mowing, plowing, cutting, or, in calm weather and under adequate safeguard, by burning. Burning should not be permitted within the 50-foot space specified in (b) below, and brush, grass, wood, etc., in piles will not be burned within 200 feet of a magazine.

(6) A firebreak at least 50 feet wide and as free as practicable from inflammable material will be maintained around each above-ground magazine. The earth adjacent to and extending over igloo magazines will not be cleared of vegetation other than dry debris. Firebreaks around the entire magazine area and at other places within the magazine area, such as along railroad tracks, should be maintained wherever possible.

(7) All locomotives used in or near a magazine will be so equipped

or of such a type that the possibility of their setting or communicating a fire is reduced to a minimum.

(8) Water lines should be divided into sections by cut-off valves, and water mains should not be located under railroads or roads used for conveying large quantities of explosives and ammunition, as a detonation of a large quantity of explosives over a water main may cause the loss of all the water in the system. Railroad cars or trucks loaded with explosives or ammunition will not remain over water lines longer than is necessary to pass from one side to the other.

(9) The use of highly inflammable liquids, especially gasoline, for cleaning purposes should be eliminated. Solvent, dry-cleaning (Federal Specifications P-S-661, SNL K1-2a), will be used in all cases in which solvents of this nature are required. It should be remembered, however, that dry-cleaning solvent is also inflammable, differing from gasoline in having a higher flash point. In handling dry-cleaning solvent, AR 850-20, "Precautions in Handling Gasoline," should be observed in all cases. This regulation should not be interpreted to forbid the use of carbon tetrachloride, trisodium phosphate, and other noninflammable cleaning agents. Due to the toxicity of vapors from cleaning agents adequate ventilation must be provided.

(10) Parking of automobiles in the immediate vicinity of ammunition or explosives areas should be so controlled as to minimize fire hazards. Fires of either accidental or incendiary origin may, by causing fuel-tank explosions, result in trails of burning fuel carrying the conflagration to adjacent cars or buildings.

(11) The use of metal tools, fixtures, and equipment which are not grounded should be kept to a minimum.

(12) These rules will be supplemented by such additional rules as the commanding officer deems necessary to secure adequate protection against fires at his establishment.

*d. Fire-fighting facilities.*—A fire involving explosives or ammunition may result so quickly in an intense conflagration or explosion that means for immediately attacking the first small blaze detected are vitally important, and reliance must often be placed upon hand equipment which can be maintained ready for immediate use. In addition to fire extinguishers, the following types of fire-fighting equipment may be used to good advantage.

(1) Water barrels and buckets placed at each magazine. If this class of fire-fighting equipment is always maintained so that it can be depended upon in case of fire, it is a valuable fire protection. However, in the summertime the barrels must be frequently refilled, and in freezing weather brine must be used. Buckets deteriorate rapidly



unless they are frequently painted or protected from the weather, and are blown about by windstorms if they are not securely fastened in place by some device which can be released at will.

(2) Sand boxes and buckets, with shovels.

*e. Fire-fighting.*—General instructions which will be followed in combating any fire involving explosives and ammunition are as follows:

(1) When a guard discovers smoke coming from a closed or locked magazine or other evidence that a magazine is afire, he will give the alarm as quickly as possible. He will fail in his duties if he attempts to go to the burning building and thereby possibly get trapped so that he cannot give the alarm.

(2) When a guard or watchman or other person discovers a grass fire, he will immediately give the alarm. If a box of fixed ammunition catches fire there is usually time to extinguish it, as it takes 10 minutes or more for fire to cause an explosion of fixed ammunition in boxes.

(3) Fire-fighting forces, when they arrive, will attack a grass fire vigorously and endeavor to extinguish it even when it is close to a magazine.

(4) In case a fire has actually gained headway in a magazine, fire-fighting forces should be directed not to endanger themselves in hopeless efforts to extinguish the fire, but to devote their efforts to saving the adjacent buildings.

(5) Forces engaged in fighting fires involving dangerous explosives and ammunition will always seek such cover as is available and will never unnecessarily expose themselves to the intense heat generated by burning smokeless powder, or to flying fragments from exploding ammunition. Many serious accidents have occurred to personnel running from a fire, while others much nearer to the danger have escaped injury because they were protected by cover which in some cases was very slight, such as a tree, shallow ditch, etc. Fire-fighting equipment must be halted 200 yards from a fire and all available cover used.

## SECTION II

### STORAGE

	Paragraph
General storage precautions.....	114
Magazines and magazine areas.....	115
Quantity-distance classes and tables.....	116
Storage chart—combination storage.....	117
Storage of specific types.....	118

114. General storage precautions.—*a.* General storage regulations are contained in AR 700-10. Regulations for ordnance depots

and manufacturing plants are contained in the Ordnance Safety Manual (O. O. Form 7224). The regulations and instructions in this manual are for posts, camps, and stations.

*b.* Explosives and ammunition should be stored in buildings designed, designated, and isolated for the specific purpose. Explosives and ammunition should not be stored in buildings which are used for other purposes, such as basements or attics of barracks, company supply rooms, or general storehouses. When specially constructed magazines are not available, the buildings used must afford good protection against moisture and dampness and have means for adequate ventilation. They must be floored with approved material and may not be heated by open fires or stoves.

*c.* In these general precautions, the word "magazine" is extended to cover any closed space containing a supply of explosive material and includes such places as a railroad car, the hold of a ship, the body of a motor truck, or a temporary shelter. In matters pertaining to storage, the word "ammunition" when unqualified is restricted to mean fixed, semifixed, and separate loading shell and shrapnel.

*d.* Boxes, cases, and other containers of ammunition should be clean and dry before being stored. Damaged containers will be repaired or replaced before storing but the repair or change of container will not take place in or within 100 feet of a magazine containing explosives. Powder dust, particles of explosive material from broken containers, will be carefully taken up as soon as spilled. All work will be suspended until this has been done. Ammunition containers should not be opened in a magazine nor should they be stored after having been opened unless they have been closed securely. No nails or tacks will be driven into a container of explosives or ammunition. Cases should be handled with care so as not to split the metal liners. Cases should not be dragged across the floor in magazines as this practice has resulted in starting fires where there was powder dust present.

*e.* Loose rounds or components will not be kept in a magazine. No empty container, no excess dunnage, no tools, should be permitted to remain in a magazine. No oily rags, paint, turpentine, etc., will be left in a magazine containing ammunition or explosives.

*f.* Ammunition should be piled by lot number in stable piles which are so arranged that the individual containers are accessible for inspection and offer no obstacle to the free circulation of air. The tops of ammunition piles will be below the level of the eaves to avoid the heated space directly beneath the roof. The bottom layer should be raised off the floor about two inches. Dunnage should be level; if necessary, shims or wedges should be used. Stacks should not be

so high that ammunition or its containers in the lower layers will be crushed or deformed. Partly filled boxes should be fastened securely, marked, and kept on the top of the pile.

*g.* Chemical ammunition is stored separately and is so placed that every container may be inspected for leaks and may be easily removed.

*h.* Doors of magazines should be closed while locomotives or motor trucks are passing or pulling up. They should not be opened again until the locomotive has passed or the truck has passed or stopped and the motor has been turned off. Truck motors should not be started while the magazine door is open.

**115. Magazines and magazine areas.**—*a. Magazines.*—Magazines should be designed, constructed, and located with special attention to the class of materials to be stored therein and should comply with the following general requirements:

(1) Magazines should be constructed of materials which, in the event of an explosion, will not form dangerous missiles or firebrands.

(2) Magazines should be fireproof unless the nature of the hazard permits the use of a frame building covered with fire-resistant material such as corrugated sheet asbestos.

(3) Each magazine should be provided with ventilators which should be well screened against sparks.

(4) All doors should be made to fit tightly so as to seal against sparks, dust, and dirt, and should be covered with fire-resistant material.

(5) Magazines should be built on well-drained ground.

(6) Magazines must be located so as to be accessible to adequate transportation facilities.

(7) Magazines must be protected against lightning.

*b. New construction.*—The Chief of Ordnance has prepared drawings and specifications for magazines. The construction of new buildings or magazines for the storage of explosives and ammunition will be in accordance with such drawings. Lay-out plans for proposed magazine areas and their location on a reservation must be approved by the Chief of Ordnance.

*c. Magazine areas.*—(1) It is essential that explosives and ammunition be segregated in an area specifically set aside for their exclusive storage. This area need not be large, but it is important that it be segregated from barracks, hospitals, administration buildings, public highways, inhabited buildings, and railroads. Individual magazines must be separated by distances adequate to prevent propagation of an explosion from one to another. Such distances are given in paragraph 116.

(2) A magazine area must be inclosed with a "climb proof" fence

and should be posted to show the presence of explosives and to prohibit smoking, trespassing, and hunting.

**Caution:** As signs are often used for targets, they should not be attached directly to magazines as many explosives may be ignited, exploded, or detonated by penetration of a rifle bullet.

(3) Fences should always be maintained in good condition and a guard stationed at every unlocked gate.

(4) Vegetation should be controlled and leaves, grass, and rubbish removed from the area and burned.

(5) Accumulation of trash, empty boxes, scrap lumber, or any such inflammable material should not be permitted.

(6) A 50-foot firebreak should be established around each above-ground magazine.

(7) Smoking, the carrying of matches, and the use of lights other than approved electric lights are forbidden.

(8) Magazine areas should be laid out with regard to access from more than one direction; roads and tracks should be looped. Water supply should be from a network of mains rather than from a single pipe line in order to insure against an important section being cut off.

(9) Magazines should not be located over important water mains or close enough to important power lines to damage them in case of an explosion.

*d. Care and maintenance.*—Regular inspection will be made of each magazine and magazine area to see if repairs are needed and to make sure the safety regulations set forth herein are strictly followed.

(1) Roofs should be maintained in the best possible condition and ventilators screened against sparks. There should be no unprotected openings around the foundation and no cracks in the walls. Doors should be tight and sparkproof.

(2) Interiors of magazines should be clean. Paint, oil, gasoline, waste, rags, and other inflammable material should not be left in magazines.

(3) Floors should be free of grit and such stains as those caused by exuding shell or dynamite. Exudate from shell should be removed by scrubbing with hot water. Exudate or oily stain from dynamite should be removed by scrubbing with a solution of 2 pounds of sodium or potassium sulfite in  $\frac{1}{2}$  gallon each of water and wood alcohol.

(4) The 50-foot firebreak should be maintained free from inflammable materials. Fire-fighting equipment such as water barrels and sand boxes should be kept full and ready for use.

(5) Magazines should be kept locked except when opened for necessary operations or inspections.

(6) When open, a magazine should be in the personal care of an officer or other responsible person, other than the nearest sentry.

(7) Keys should be in the care of the responsible officer or noncommissioned officer.

(8) The person in charge of operations should make sure that all doors and shutters are securely locked when leaving the magazine.

(9) A magazine placard, "Storage and Care of Explosives" (O. O. No. 5991), should be posted in every magazine in such position that it will be conspicuous to all personnel working therein.

*e. Repairs.*—(1) Magazines will be repaired under the direct supervision of a competent person who will decide whether or not the contents of the magazine are to be removed while repairs are made. Under normal conditions, roofs, lightning rods, ventilators, doors, etc., may be repaired and minor repairs to the interior of the magazine may be made without removing the contents. This does not apply to magazines containing high explosives in bulk or black powder.

(2) When magazines are repaired, the general safety regulations set forth will be complied with. In addition, the following special regulations will be observed:

(a) Work will be done by careful, experienced workmen.

(b) Nonsparking tools will be used if practicable.

(c) The floor in the vicinity of the work will be swept and any stains scrubbed with hot water.

(d) No work requiring soldering, melting of asphalt, or any use of a blowtorch will be done in a magazine containing explosives or ammunition.

(e) No repairs will be made to the interior of a magazine containing bulk explosives until all explosives have been removed and the interior washed with water.

(f) All workmen should be searched for matches before being allowed to enter any magazine.

(g) All magazines should be carefully swept after repairs have been completed and all tools should be removed.

(h) The magazine will be inspected by competent authority after repairs have been completed.

**116. Quantity-distance classes and tables.**—*a.* To reduce to a minimum the hazards and risks due to fire and explosion, these regulations are prescribed:

(1) The distances that will be maintained between magazines at military establishments and public highways, public buildings, public railways, and inhabited buildings.

(2) The distances that will be maintained between magazines.

(3) The maximum quantity that will be permitted in any one magazine.

b. These precautions not only protect persons and property in the territory adjacent to military establishments, but also reduce to a minimum the possibility of any explosion involving large masses of explosives and ammunition, and limit the quantity of military supplies that may be lost in any one explosion.

(1) In time of war, military requirements may make full compliance with safety regulations impracticable. Since the purpose of these regulations is to reduce to a minimum the losses to personnel and stores, the intent of the regulations will be complied with as far as practicable.

(2) In time of peace, the quantity-distance tables set forth below will be strictly complied with except when subject to reductions under special conditions as indicated below and in case of existing emplacement magazines at harbor defense installations. Such harbor defense magazines may be used for the storage of ammunition pertaining to the armament of the emplacement and not in excess of its war reserve allowance. Magazines of emplacements which have had their armament removed or become obsolescent may be used for the storage of any class of ammunition and explosives, provided the quantity-distance tables are complied with.

c. The distances specified in these tables offer protection against structural damage and most missiles. Occasional missiles which travel a mile or more are not considered because of their rarity—especially when the amount of material involved in one explosion is limited by keeping piles small and spacing them so as to limit the explosion to one pile. It will be noted that the distances specified in the tables are not based on the total amount of explosives in the magazines but upon the missile hazard and the amount that may be involved in one explosion. The specified distances may be changed under the following special conditions:

(1) When a magazine is effectively barricaded or screened from other buildings, magazines, railroad, and highway, the distances may be reduced one-half in cases not specifically forbidden in the tables. Effective screening will be by natural features of the ground or by an artificial barricade at least 4 feet from the magazine, at least 3 feet thick at the top, at least high enough so that the straight line extended from the top of the side wall of the magazine to the top of the barricade will pass above any part of a building to be protected and at least 12 feet above any public highway or public railway.

(2) Magazines of standard earth-covered concrete arch type and emplacement magazines are considered barricaded on all sides except

that of the entrance, which side may be barricaded if local conditions require.

(3) Harbor defense emplacement magazines in a group, being separated from each other by substantial dividing walls, need not comply with the intermagazine distances. However, each magazine, as a unit, must comply with the table distances for inhabited building, public highway, and public railroad.

(4) Where the construction of the magazine is such as effectually to stop the missiles resulting from an explosion therein, the distances prescribed for class 9, bulk explosives, may be used in place of those prescribed for the class to be stored. Such magazines are the standard earth-covered concrete arch type (igloo) and emplacement magazines. The quantity to be considered will be the total quantity to be stored in the magazine except where specific cases are excepted in (5) below.

(5) (a) The distances prescribed for quantities of explosives and ammunition of classes 3, 4, and 5 (defined below), stored in magazines similar to the prescribed ordnance types, may be computed by taking the actual weight of explosive material contained in each item and multiplying by the number of such items. The amount contained is shown in pertinent Technical Manuals and regulations and ordnance drawings which are available on request from the Chief of Ordnance. If the distances for such quantities of explosive or combinations of explosives are greater than the distances prescribed for the same amount of bulk explosive, as shown in the table for classes 9 and 10, the lesser distance may be taken as the minimum safe distance.

(b) Components of class 6 should be stacked in piles each containing not more than 5,000 pounds of explosive material and having at least 2 feet clearance from all other piles. In this case the quantity to be considered is the amount in one pile. If this regulation cannot be complied with, the distances for classes 9 and 10 will govern and the total amount of explosives in the magazines will be taken as the quantity. The maximum quantity permitted, however, will be 10,000 pounds or the numerical limit, whichever is less.

(c) Ammunition in group 7 will be stored in piles with not more than 15,000 pounds of explosive in each pile or row. The manner of piling and the distances to be maintained between piles will be in accordance with O. O. drawing 19-48-12 (figs. 63 and 64). The quantity of ammunition to be considered will then be the maximum quantity in any one pile, and distances may be reduced accordingly, provided that the lateral (side to side) distances are in excess of 16 feet. Where this distance is less than 16 feet the total quantity will be the maximum quantity in any row. Where compliance with such conditions and clearances is omitted, as is sometimes necessary in

underground magazines, the total amount of explosive material in the magazine and the distances to be observed will be taken from the table for classes 9 and 10.

*d.* The terms used in the following tables are defined as follows:

(1) *Inhabited building*.—Any building regularly occupied or customarily used as a habitation, church, schoolhouse, office, hospital, railroad station, or for purposes of assembly, except buildings on a military reservation where essential military requirements necessitate sites close to a magazine. The land limits or boundaries of military reservations will be considered possible sites of inhabited buildings.

(2) *Public railway*.—Any steam, electric, or other railroad which carries passengers for hire.

(3) *Public highways*.—Any street, alley, road, or navigable stream.

(4) *Navigable stream*.—A body of water capable of extensive navigation by tugs, barges, and other large vessels.

(5) *Nearest magazines*.—The nearest magazines containing explosives or ammunition. The amount of explosives or ammunition permitted to be stored in a magazine can sometimes be increased if the nearest magazines are filled with inert materials, thus greatly increasing the distances to the nearest magazine containing explosives or ammunition.

(6) *Maximum permitted*.—The largest amount of explosives or ammunition permitted to be stored in a magazine even if it is more isolated than the tables prescribe. It is imperative that the loss of military supplies be reduced to an absolute minimum.

(7) *Structural damage*.—The serious weakening or displacement of foundations or brick or stone supporting walls or the breaking of wooden main supporting members in outside or inside walls. No readily reparable damage such as broken glass or loosened plaster is considered structural damage.

*e.* The explosive contents of ammunition or components are shown in the Technical Manuals for each caliber and type of gun. They are also shown on ordnance office drawings. If such information is not available, it will be requested from the Chief of Ordnance. The quantities shown in the tables were computed in the following manner:

(1) *Smokeless powder*.—The quantities in pounds are the net weights of the powder in the boxes or in the propelling charges.

(2) *Pyrotechnics*.—The quantities are the gross weights of boxes and contents.

(3) *Separate and unfixed shell and bombs*.—The quantities are computed by taking the net weight of explosive in the charge of one shell and multiplying by the number of shell or bombs in the magazine.



(4) *Fixed ammunition.*—The quantity is the net weight of the high explosive charge in the shell multiplied by the number of rounds. The smokeless powder propelling charge is so much less hazardous that it is not included in the computation for this class of ammunition.

*f.* The grouping of explosives and ammunition into classes in this section means that the hazards are similar for all items of a group. It does not imply that the items of a class are intended to be stored together or even that it is permitted that they be stored together. Combination storage is discussed in paragraph 117.

*g.* When military explosives and ammunition are packed in accordance with the provisions of War Department drawings and specifications, they may be grouped, according to the degree of hazard involved, into the following classes:

(1) *Class 1. Small arms ammunition and mechanical time fuzes without boosters.*—This is principally a fire hazard and no limit has been placed on the storage of this class, except the limit on number of fuzes. See note (3) to table for class 3.

(2) *Class 2. Smokeless powder, pyrotechnics, and chemical ammunition containing phosphorus.*—These materials under extreme conditions of moisture, high temperature, or age may become unsafe. They burn with intense heat but do not usually form dangerous missiles or generate pressures which will cause serious structural damage to adjacent magazines.

Quantity-distance table for class 2

Quantity; pounds of explosives (not over)	Unbarricaded distance <sup>1</sup> in feet from nearest—			
	Inhabited building	Public railway	Public highway	Magazine
10,000-----	150	150	150	100
100,000-----	300	300	300	200
200,000-----	375	375	375	250
500,000 <sup>2</sup> -----	600	600	600	400

<sup>1</sup> Reduction of distances to one-half for barricades is permitted only in the case of concrete igloo or emplacement magazines.

<sup>2</sup> Maximum permitted in any one magazine.

(3) *Class 3. Point-detonating fuzes, minor caliber base detonating fuzes, powder train and antitank mine fuzes, packed separately in boxes; bomb fuzes, packed with fin assemblies.*—These usually explode progressively, not more than a box or two at a time. Pressures that will cause structural damage to adjacent magazines are usually not generated. Missiles are small and light and usually fall within 100 yards.

Quantity-distance table for class 3

Quantity; pounds of explosives (not over)	Distance <sup>1</sup> in feet from nearest—			
	Inhabited building <sup>2</sup>	Public railway <sup>2</sup>	Public highway <sup>2</sup>	Magazine
50.....	400	400	400	60
200.....	400	400	400	100
1,000.....	400	400	400	180
10,000 <sup>3</sup> .....	400	400	400	300

<sup>1</sup> These distances will not be reduced by barricades except that one-half the above distances is authorized for concrete igloo or emplacement magazines.

<sup>2</sup> Distance that missiles will travel.

<sup>3</sup> Maximum weight permitted in one magazine. However, not more than 50,000 fuzes of any one model, nor more than 150,000 fuzes of any number of models, will be stored in one magazine without prior approval of the Chief of Ordnance.

(4) *Class 4. Fixed and semifixed high explosive shell, trench mortar ammunition, fragmentation bombs in wooden containers, grenades, shrapnel of all calibers, fuzed and unfuzed, and blank ammunition for cannon—packed in boxes or bundles.*—Articles in this class usually explode progressively only a few boxes at a time and many explosions of individual rounds are of a very low order. Pressures which will cause structural damage to adjacent magazines are usually not generated. Most missiles will fall within 200 yards.

Quantity-distance table for class 4

Quantity; pounds of explosives (not over)	Unbarricaded distance <sup>1</sup> in feet from nearest—			
	Inhabited building	Public railway	Public highway	Magazine
50.....	1, 200	1, 200	1, 200	60
500.....	1, 200	1, 200	1, 200	140
1,000.....	1, 200	1, 200	1, 200	180
50,000.....	1, 200	1, 200	1, 200	225
500,000 <sup>2</sup> .....	1, 200	1, 200	1, 200	300

<sup>1</sup> These distances will not be reduced by barricades except that one-half of these distances is authorized for concrete igloo and emplacement magazines.

<sup>2</sup> Maximum permitted to be stored in any one magazine.

(5) *Class 5. Separate-loading and unfixed shell, loaded with explosive D, fuzed or unfuzed.*—These usually explode one shell at a time and, in nearly all cases, with low order. The missiles are limited as to number and range, and most of them fall within 400 yards.

Quantity-distance table for class 5

Quantity; pounds of explosives (not over)	Distance <sup>1</sup> in feet from nearest—			
	Inhabited building	Public railway	Public highway	Magazine
1,000-----	1, 200	1, 200	1, 200	100
25,000-----	1, 200	1, 200	1, 200	200
650,000 <sup>2</sup> -----	1, 200	1, 200	1, 200	300

<sup>1</sup> These distances will not be reduced by barricades except that one-half of these distances is authorized for concrete igloo and emplacement magazines.

<sup>2</sup> Maximum permitted to be stored in any one magazine.

(6) *Class 6. Major and medium caliber base-detonating fuzes, bomb fuzes, boosters and bursters for high explosive and chemical shell and bombs—packed separately in boxes.*—These usually explode progressively by piles. Structural damage caused by the pressures generated is usually limited to adjacent magazines. Missiles are light and usually fall within 200 yards. When items of this class are stored in concrete igloo magazines, the quantity-distance requirements of Class 9, bulk explosives, will govern. The quantity to be considered will be determined in accordance with *c(5) (b)* above.

Quantity-distance table for class 6

Quantity; pounds of explosives (not over)	Distance <sup>1</sup> in feet from nearest—			
	Inhabited building	Public railway	Public highway	Magazine
50-----	240	140	70	60
200-----	240	140	70	100
5,000-----	1, 500	900	450	200
100,000 <sup>2</sup> -----	1, 500	900	450	300

<sup>1</sup> These distances will not be reduced by barricades nor by storage in concrete igloo or emplacement magazines.

<sup>2</sup> Maximum weight permitted in one magazine. However, not more than 50,000 fuzes of any one model nor more than a total of 150,000 fuzes of any number of models will be stored in one magazine without prior approval of the Chief of Ordnance.

(7) *Class 7. Separate and unfixed shell of all calibers, except those loaded with explosive D.*—All in a magazine may explode but the explosion may be limited to one pile by arranging the material in accordance with instructions for piling separate loading shell given in *c(5)* above and paragraph 118*g(2)*. Structural damage is usually limited to adjacent buildings. Most missiles will fall within 500

yards. When items of this class are stored in concrete igloo magazines, the quantity-distance requirements of Class 9, bulk explosives, will govern. The quantity to be considered will be determined in accordance with *c(5)(c)* above.

Quantity-distance table for class 7

Quantity; pounds of explosives (not over)	Distance <sup>1</sup> in feet from nearest—			
	Inhabited building	Public railway	Public highway	Magazine
25,000-----	1, 800	1, 800	1, 800	200
500,000 <sup>2</sup> -----	1, 800	1, 800	1, 800	300

<sup>1</sup> These distances will not be reduced by barricades nor by storage in concrete igloo or emplacement magazines.

<sup>2</sup> Maximum permitted in any one magazine.

(8) *Class 8. Primers, primer-detonators for bombs, grenade fuzes, and blasting caps—packed in metal containers and wooden boxes.*—All in a magazine may explode at one time but as the total amount of explosives is small and they are not closely confined, structural damage is usually limited to adjacent magazines. Light missiles are formed which have a very limited range.

Quantity-distance table for class 8

Quantity; pounds of explosives (not over)	Distance in feet from nearest—			
	Inhabited building	Public railway	Public highway	Magazine
50-----	240	140	70	60
500-----	720	430	220	140
2,000-----	980	590	300	300
5,000-----	1, 200	720	360	300
10,000-----	1, 500	900	450	300
15,000-----	1, 610	970	490	300
20,000 <sup>1</sup> -----	1, 740	1, 040	520	300

<sup>1</sup> Maximum weight permitted to be stored in any one magazine.

(9) *Class 9. Flashlight powder, demolition blocks, spotting charges, bulk low explosives, bulk priming explosives, bulk initiating explosive such as tetryl, bulk high explosives such as TNT and explosive D.*

(10) *Class 10. Demolition bombs, fragmentation bombs in metal crates, photoflash bombs, and HE antitank mines.*—All in a magazine may explode at one time. If this happens, structural damage, caused

by the pressures generated, is not likely to occur at the distances given in the table and most missiles will fall well within these distances.

Quantity-distance table for classes 9 and 10

Quantity; pounds of explosives (not over)	Distance in feet from nearest—			
	Inhabited building	Public railway	Public highway	Magazine
50	145	90	45	60
100	240	140	90	80
200	360	220	110	100
300	520	310	150	120
400	640	380	190	130
500	720	430	220	140
600	800	480	240	150
700	860	520	260	158
800	920	550	280	165
900	980	590	300	170
1,000	1,020	610	310	180
1,500	1,120	680	340	210
2,000	1,200	720	360	230
3,000	1,320	790	390	260
4,000	1,420	850	420	280
5,000	1,500	900	450	300
6,000	1,560	940	470	300
7,000	1,610	970	490	300
8,000	1,660	1,000	500	300
9,000	1,700	1,020	510	300
10,000	1,740	1,040	520	300
15,000	1,870	1,120	560	300
20,000	2,010	1,200	600	300
25,000	2,140	1,290	640	300
30,000	2,280	1,370	680	300
40,000	2,550	1,530	760	300
50,000	2,800	1,680	840	300
75,000	3,310	1,990	1,000	400
100,000	3,630	2,180	1,090	400
150,000	3,800	2,280	1,140	800
200,000	4,060	2,440	1,220	800
250,000 <sup>1</sup>	4,310	2,590	1,300	800

<sup>1</sup> Maximum permitted in any one magazine.

(11) *Class 11. Chemical ammunition, except ammunition containing phosphorus.*—Chemical shell, bombs, and grenades stored and issued by the Ordnance Department are not considered to be an explosive hazard and no limit has been placed on this type of ammunition as far as quantities and distances are concerned. However, there

are restrictions on the storage of such ammunition which are set forth in paragraphs 117 and 118*k*.

(12) *Class 12. Explosives such as ammonium nitrate, DNT, and wet nitrocellulose.*—These materials are insensitive and can be detonated only by very strong initiation. When stored in an explosives area where there is a possibility that explosives may be projected into them, they will be stored in accordance with the regulations for Class 9 explosives. When stored in an area of fire hazards only and separated by inhabited building distances from areas containing explosives or ammunition, these materials may be stored in accordance with the regulation for smokeless powder.

**117. Storage chart—combination storage.**—*a. Storage chart.*—

(1) The following chart shows the explosives and ammunition which may be stored together subject to the quantity-distance tables, paragraph 116. The X in the intersection of a horizontal row and a vertical column indicates that these items may be stored together. As one example, small-arms ammunition may be stored with pyrotechnics. Where the X appears in all of the intersections within a group, any or all of the items in the group may be stored together. For example, any or all of the items in group C may be stored in one magazine.

(2) When two items are stored together in accordance with this rule, additional items may be stored therewith only if each of the additional items is authorized for storage with all of the other items. For example, if small-arms ammunition and pyrotechnics are stored together, antitank mine fuzes may not be added because the chart does not authorize the storage of antitank mine fuzes with pyrotechnics.

(3) Where the X does not appear at the intersection of a row and a column, the two items may not be stored together in one magazine except in the cases and under the conditions noted in *b* below.

# STORAGE CHART

## GROUPS

See paragraph 117 for use of chart and exceptions

GROUPS		Bulk black powder, saluting, practice bomb and smoke puff charges	TNT (bulk) and demolition blocks	Dynamite	Explosive D	Smokeless powder, bulk or charges	Small-arms ammunition	Fixed and semifixed HE shell and shrapnel	Blank ammunition for cannon	Separate loading shrapnel	Fragmentation bombs (wood crates)	Light mortar shell (81-mm and less)	Grenades, fragmentation and practice	Antitank mines, practice	Fuzes, time and detonating	Primers and primer detonators	Detonators, blasting and percussion caps	Grenade fuzes	Adapters, boosters, and bursters	Fuzes, antitank mine	Demolition bombs	Fragmentation bombs (metal crates)	Separate loading shell	Antitank mines, HE	Pyrotechnics
A	Bulk black powder, saluting, practice bomb, and smoke puff charges	X																							
	TNT (bulk) and demolition blocks		X		X																				
	Dynamite			X																					
B	Explosive D		X		X																				
	Smokeless powder, bulk or charges					X																			
	Small-arms ammunition						X	X	X	X	X	X	X	X	X	X	X	X	X				X		
C	Fixed and semifixed HE shell and shrapnel						X	X	X	X	X	X	X	X											
	Blank ammunition for cannon						X	X	X	X	X	X	X	X											
	Separate loading shrapnel						X	X	X	X	X	X	X	X											
	Fragmentation bombs (wood crates)						X	X	X	X	X	X	X	X											
	Light mortar shell (81-mm and less)						X	X	X	X	X	X	X	X											
	Grenades, fragmentation and practice						X	X	X	X	X	X	X	X											
	Antitank mines, practice						X	X	X	X	X	X	X	X											

	Fuzes, time and detonating						X							X	X	X	X	X	X				
	Primers and primer detonators						X							X	X	X	X	X	X				
D	Detonators, blasting and percussion caps						X							X	X	X	X	X	X				
	Grenade fuzes						X							X	X	X	X	X	X				
	Adapters, boosters, and bursters						X							X	X	X	X	X	X				
	Fuzes, antitank mine						X							X	X	X	X	X	X				
	Demolition bombs																			X	X		
E	Fragmentation bombs (metal crates)																			X	X		
F	Separate loading shell																					X	
G	Antitank mines, HE																						X
H	Pyrotechnics						X																X
I	Chemical amm., gr. A (vesicant)																						
J	Chemical amm., gr. B (gas and smoke)																						
K	Chemical amm., gr. C (phosphorus)																						
L	Chemical amm., gr. D (burning)																						
M	Bombs, photoflash																						
N	Flashlight powder																						

Stored separately



*b. Exceptions to storage chart.*—(1) When the total quantity of explosive or chemical fillers in a magazine is 1,000 pounds or less, the following exceptions to the storage chart are authorized:

(2) Any combination of items in group A and group B may be stored in one magazine.

(3) Any combination of items in group C and group D may be stored in one magazine.

(4) Any combination of items in group H and group L may be stored in one magazine.

(5) Small-arms ammunition and any combination of items in group I, group J, and group L may be stored in one magazine.

(6) Small-arms ammunition and items in group M may be stored in one magazine.

**118. Storage of specific types.**—*a. Black powder.*—(1) Black powder in bulk, saluting charges, practice bomb charges, and smoke-puff charges should be stored in dry, and if practicable, in bulletproof magazines. Black powder will never be handled or stored in a barracks, general supply room, inhabited building, or any building heated by stoves or open fires. In a magazine containing black powder, safety shoes will be worn and no work will be done other than that involved in the actual storage and removal of the powder in containers and the brushing up of spilled grains. Black powder does not deteriorate in storage if kept dry. Containers of saluting, practice, and smoke-puff charges are stored with tops up. Containers of black powder are carefully examined on receipt for weak spots and holes, with special attention to examination for small holes, such as nail punctures, which are not evident without close scrutiny. Damaged containers are not repaired; their contents are transferred to serviceable drums. Condensed moisture may rust the container or the cap may corrode. Containers may be painted, caps replaced, or contents transferred under the following conditions:

(2) The work will be done at least 100 feet from any magazine containing explosives or ammunitions.

(3) If any powder is spilled, work will stop until the spillage is carefully taken up and the spot washed with water. The powder taken up will be destroyed by dumping in water.

(4) If tools are required to open a container, only safety tools will be used, and the operator will be protected by a barricade and the work will be done in strict compliance with instructions issued for this purpose by the Chief of Ordnance.

(5) The quantity of powder in the vicinity of operations will be kept to a minimum.

(6) Special care will be observed to see that all information

marked on the original container is reproduced when repainting the old container or transferring the contents to a new container.

(7) Empty black powder containers will be thoroughly washed out with water.

*b. High explosives—TNT, explosive D, tetryl, triton blocks.*—These are stable in storage and require only protection from moisture and, if practicable, from rifle bullets. They are stored in wax paper-lined wooden boxes. In handling loose explosives of this class, safety shoes should be worn. Nonsparking tools should be used in opening boxes. Broken containers may be repaired or contents transferred only at a distance of 100 feet from a magazine containing explosives or ammunition.

*c. Dynamite.*—Dynamite is sensitive to heat and shock. It should be stored in fireproof, bulletproof magazines. Nonsparking tools will be used in opening cases. Empty containers that have been used for dynamite will be destroyed by burning. Oily stains of nitroglycerin will be scrubbed up with a solution consisting of  $\frac{1}{2}$  gallon of water,  $\frac{1}{2}$  gallon of wood alcohol, and 2 pounds of sodium sulfite or potassium sulfite. Dynamite should be kept out of the direct rays of the sun.

*d. Bulk smokeless powder and separate loading propelling charges.*—(1) These should be stored insofar as practicable in accordance with ordnance drawings in magazines which are well ventilated and dry. Since smokeless powder is principally a fire hazard, a well-ventilated frame structure covered with corrugated sheet asbestos and built on well-drained ground may be used. Such buildings are often more easily kept dry than fireproof magazines. Bulk smokeless powder is packed in all steel or in metal-lined wooden boxes, which are stored on their sides with dunnage enough to insure free circulation of air through all parts of the pile.

(2) Containers of propelling charges up to 10 inches in caliber are stored in racks. Containers of charges 10 inches and over may be stored on their bases or on their sides. If stored on their sides, provision must be made to prevent the weight of the upper layers crushing the containers in the lower.

(3) All boxes and containers should be stored so that the covers can be readily inspected or removed and so that the containers may be air-tested in storage.

(4) Magazines in which smokeless powder is stored should be equipped with a maximum thermometer which should be read daily or as often as necessary. If the temperature exceeds  $100^{\circ}$  F. for 24 hours or  $85^{\circ}$  F. for 72 hours, the magazine should be cooled by wetting down the exterior with water or by opening the doors and ventilators

at night and closing them in the morning. If this fails to reduce the temperature, the commanding officer will decide whether the stores are to be removed to another magazine. When magazines are cooled by such ventilation at night effective measures will be taken to protect against fire and to close the doors in case of rain.

(5) Smokeless powder, in bulk or in separate loading charges, is always packed in airtight containers. It is important that such containers remain airtight until the powder is used. When a shipment is received, every container is given a visual inspection to see that it is not damaged and that the cover is in good condition and tight.

(6) Metal containers for propelling charges are fitted with a test hole and plug in the cover so that they can be tested for airtightness. Every container in which a propelling charge is stored will be air-tested when received and whenever it is subject to handling that might cause it to leak. The testing should be done with an apparatus similar to that described in O. O. drawing 24-12-2, providing, however, that no motor-driven air compressor will be taken into a magazine in which explosives or ammunition are stored. A pressure of 3 to 5 pounds is used and if no drop in pressure is observed in one minute it may be assumed the case is not leaking.

(7) Every leaking container will be repaired or the contents transferred to an airtight container. If the contents of any container show evidence of dampness or moisture, it should be segregated and reported to the corps area or department ordnance officer. Leaks due to covers or gaskets may be repaired without removing the charge from the container or the container from the magazine, provided care is taken to guard against sparks. Repair of leaks in other parts of the container will be undertaken only after the removal of the charge from the container and the container from the magazine.

(8) Personnel engaged in air testing will be familiar with the odor and appearance of decomposing powder. They should examine each container opened for air test for the characteristic odor. One of the first evidences of dangerous deterioration is the presence of the acid odor of nitrous fumes in place of the normally present odor of alcohol-ether. The odor of decomposing powder is so characteristic that it should not be mistaken.

(9) Fiber containers of separate loading propelling charges are not opened unless they are damaged; then the charge is transferred to a serviceable metal container. Fiber containers are not repaired.

(10) Metal containers may rust. They may be repainted but must be removed from the magazine to do so. Care must be taken to reproduce faithfully the original markings whenever containers are repainted or changed.

(11) Some fine-grain smokeless powders are almost as sensitive as black powder and equal precautions should be observed. The principal safety measure in regard to smokeless powder, however, is the careful watch for deterioration.

(12) The normal odor in a smokeless powder magazine is a faint odor of alcohol-ether. If this odor is strong, it probably indicates a leaky container.

*e. Small-arms ammunition.*—Small-arms ammunition may be stored in any magazine or warehouse which offers good protection against the weather. When magazine space is limited, it may be stored in a general warehouse by partitioning or screening off a section for its exclusive use. This refers to small-arms ammunition only and not to other types with which it may be stored in a magazine. Good protection against moisture and high temperature should be provided. Free ventilation of all parts of the pile should be insured, dunnage being used where necessary. Skylights and windows near piles should be shaded so that ammunition will not be exposed to direct sunlight. Care should be taken to avoid piling ammunition near steam pipes. Nearly all types of small-arms ammunition are packed in boxes fitted with airtight metal liners and these liners should not be opened until the ammunition is about to be used. When only a part of a box is used the remaining ammunition in the box should be protected against unauthorized handling and use by firmly fastening the cover in place. Serviceable ammunition turned in by troops should not be stored in open boxes. It should be repacked for storing and reissued at the first opportunity, provided it can be identified by lot number. If it cannot be identified by lot, it automatically becomes grade 3 and should be reported to the corps area or department ordnance officer for disposition.

*f. Fixed and semifixed ammunition, grenades, and mortar shell.*—  
(1) These may be stored in any magazine with good protection from the weather but preferably in fireproof or fire-resistant magazines to reduce to a minimum the danger of fire or explosions. Most of the standard boxes and bundles in which this type of ammunition is packed are provided with cleats and those that are not may be piled with dunnage to insure free circulation of air. Except for 37-mm and smaller calibers, fixed ammunition is packed in individual sealed containers which are then bundled or boxed. If the ammunition is not removed from these sealed containers until it is used, it should remain in good condition. Serviceable rounds which have been removed from their containers, such as those turned in by troops, should be placed in containers which should then be sealed with friction tape and shellac before they are again placed in storage. This procedure will protect the

round against deterioration and the primer against accidental blows. Loose rounds should never be permitted in a magazine.

(2) Some fixed ammunition and the limited standard HE fragmentation grenade are shipped unfuzed. Assembly of fuzes to such items is forbidden within 100 feet of a magazine containing explosives or ammunition.

(3) It is sound policy to mix quantities of different sizes and types in each of several magazines rather than to store only one kind in each magazine. For example, there may be on hand a sufficient quantity of 75-mm high explosive shell to fill one magazine and enough 75-mm shrapnel for another. Rather than store all high explosive shell in one magazine and all shrapnel in another, it is better storage practice to store half of each type in each magazine. Thus, in case of accident to one magazine, there is still a supply of both types of ammunition on hand.

*g. Separate loading shell.*—(1) Separate loading and unfixed shell should be stored in fireproof magazines containing a minimum of inflammable materials. Iron or steel dunnage is preferred to wood and it should be electrically connected and grounded. If it is necessary to use wood for dunnage, the amount should be kept to an absolute minimum. Unfuzed shell should be fitted with an iron or steel fuze hole plug. If it is necessary to roll fuzed shell, it should be done carefully in order to avoid the risk of arming the fuze.

(2) In order to confine an explosion to one pile of shell, the following precautions will be observed:

(a) Shell should be piled in single piles with the noses of the shell in one pile pointing toward the noses of the shell in the next pile and with the bases of the shell in one pile facing the bases of the shell in the next pile. Shell up to and including 10 inches in diameter should be piled in accordance with figure 63, and distances specified should be maintained if the shell are loaded with TNT or amatol. If the shell are loaded with explosive D, the distances need be only large enough to permit inspection of the shell and of the fuze cavities.

(b) The nose-to-nose and base-to-base distances between rows should be equal.

(c) The nose-to-nose distances for each caliber shell are given in ordnance drawing 19-48-12 (fig. 63). They should be strictly observed and the number of shell in each pile should be kept to a minimum consistent with the storage space available.

(3) Shell over 10 inches in diameter may be stored on their sides or on their bases. When stored on their bases, there should be a 1-inch board between the shell and the floor to protect the shell from moisture; shell loaded with explosive D may be stored in intimate contact but

shell loaded with TNT should be separated by a distance equal to the caliber of the shell.

(4) The rotating bands on all projectiles should be carefully protected by rope grommets or some other effective means. Dents or cuts in the band may cause the shell to function improperly in the gun.

*h. Bombs.*—In storing bombs, a distinction must be made between the fragmentation and demolition types.

(1) Fragmentation bombs are packed in wooden boxes and metal crates. Those packed in wood are not liable to detonate in mass if a fire occurs in the magazine in which they are stored. These are stored with, and in a manner similar to, fixed ammunition. Fragmentation bombs in metal crates are stored with, and in the same manner as, demolition bombs.

(2) Demolition bombs have comparatively thin walls and comprise one of the most hazardous types of ammunition to store because of their tendency to detonate in mass if a fire occurs in, or a heated fragment be projected into, the magazine in which they are stored. Safety can be obtained only by reducing the possibility of fire to the absolute minimum. Demolition bombs should be stored in a fireproof magazine with iron or steel dunnage. If wood must be used for dunnage, the amount should be kept to a minimum. Steel dunnage should be connected electrically and grounded to the lightning protective system of the magazine. Demolition bombs not intended for immediate shipment should be unpacked and stored as above. Boxes and crates should be stored separately in a warehouse and fuzes or primer-detonators should be stored in a separate magazine.

(3) Bombs with fins attached should be piled with care not to bend or otherwise damage fins and all demolition bombs should be piled so that the fuze cavity can be easily inspected.

*i. Fuzes, primers, primer-detonators, detonators, and boosters.*—These components are usually packed in hermetically sealed containers and boxes. Care should be taken in packing to see that they are properly supported in racks or trays and protected against shock or rough handling. Even when properly packed, this class of components should be handled with great care. Boxes should be stored top up, in double row stacks, with 24-inch aisles between stacks and between outside stacks and walls. Partly filled boxes should be kept securely closed. Magazines for the storage of fuzes should be small to limit the loss of this type of material, and the quantity of fuzes, primers, etc., stored in any one magazine should be kept to a minimum, consistent with the storage space available. Storage of all on hand of any one type in a single magazine is to be avoided if possible.

*j. Pyrotechnics.*—Pyrotechnics require protection against moisture, dampness, and high temperature. Pyrotechnic material that has been wet is hazardous to store, consequently any boxes that show signs of dampness will be opened and if the pyrotechnic material is wet, it should be destroyed (see ch. 4). Pyrotechnics should be handled with care even when properly packed. Certain kinds of this material deteriorate in storage and have an expiration date on the containers. Care should be taken to observe the direction for disposal of this material at the time indicated.

*k. Chemical ammunition.*—(1) Chemical ammunition should not be stored with other classes, principally because of the difficulty and danger encountered in fighting a fire involving chemical materials. All munitions containing chemical agents are stored in such a manner that each item is accessible for inspection and may be easily removed from storage in case it should develop a leak. This type of ammunition must be inspected for leaks once a month and any leaking container is removed downwind to await disposal.

(2) Whenever a magazine containing chemical ammunition is opened, a responsible officer or foreman should be present to detect the odor of escaping gas. If such an odor is present, all persons entering the magazine will wear the protective devices proper for the group, all windows and doors of the magazine will be opened, and the leaking container sought out and removed.

(3) Each type of chemical ammunition is preferably stored alone, but may be stored with other chemicals having similar properties. The special equipment, as listed for each group of chemical agents, should be available in the vicinity, but not in the magazine. The chemical agents are grouped as follows:

(*a*) *Group A. Vesicants, HS and M1.*—Magazines for this group should have surface-hardened concrete floors. Special equipment should include gas mask, protective suit, boots, and gloves for each officer, man, or fireman whose duties require his presence in the magazine; chloride of lime, kerosene and flannel cloths, sodium bicarbonate, boric acid, soap, and ample washing facilities.

(*b*) *Group B. Toxic, irritant, and smoke-producing chemical munitions.*—Magazines should have surface-hardened concrete floors and free ventilation. Special equipment should include gas masks, gloves, saturated solution of sodium sulfite, saturated alcoholic solution of sodium hydroxide, litters, and wool blankets. Masks will be carried at all times by personnel in the magazine.

(*c*) *Group C. Spontaneously inflammable munitions, phosphorus, WP.*—This type magazine should have concrete floors with elevated sills to permit flooding. Special equipment includes tubs or barrels

filled with water and large enough to contain the largest component stored. In addition, there should be available rubber gloves and boots, sponges, pails, and copper sulfate solution.

(d) *Groups D. Incendiary and readily inflammable substances, TH, F8, HC, CN, CN-DM grenades.*—No water is to be used in this magazine. No special precautions are necessary except to keep water and fire away, and to remove leaking containers to prevent an accumulation of loose material in the magazine.

(4) Munitions from two or more groups will not be stored together without the specific approval of the Chief of Ordnance.

1. *Inert materials.*—Inert materials or empty components of ammunition such as drill cartridges, target-practice projectiles, or empty shell should be stored in buildings which afford good protection against moisture and dampness. They should be cleaned, repainted, and slushed when necessary and should not be allowed to deteriorate. Shell should be carefully stored to guard against damage to the rotating band.



CAPACITY OF MAGAZINE

SHELL HE.	DRAWING NUMBER	LENGTH OF SHELL AS STORED (APPROX.)	WEIGHT OF SHELL AS STORED (APPROX.)	WEIGHT OF T.N.T. BURSTING CHARGE	DIAMETER OF SHELL	SHELLS PER ROW			POUNDS OF EXPLOSIVE PER ROW	NUMBER OF ROWS	NOSE TO NOSE BASE TO BASE AISLE SPACE	NUMBER OF SHELLS PER MAGAZINE	TOTAL POUNDS OF EXPLOSIVE PER MAGAZINE	DIMENSION B
						LONG	HIGH	TOTAL						
6" GUN MK. II	75 - 7 - 42	25.25"	91.00	13.69	6.000"	81 X 10.8 10			11,309.22	41	38"	33,210	454,644.9	15"
125 M.M. GUN MK. III	75 - 14 - 138	23.54"	94.86	15.17	6.080"	80 X 10.8 00			12,187.20	39	41"	31,200	473,304	17"
155 M.M. GUN MK. IIIA1	75 - 14 - 228	26.88"	95.76	15.210	6.080"	80 X 10.8 00			12,168.00	38	41"	30,400	462,384	23"
165 M.M. GUN M. 101	75 - 14 - 229	26.79"	94.32	15.560	6.080"	80 X 10.8 00			12,448.00	38	41.5"	30,400	473,024	15"
155 M.M. HOW. MK. I	75 - 14 - 137	25.54"	94.86	15.17	6.080"	80 X 10.8 00			12,187.20	39	41"	31,200	473,304	17"
155 M.M. HOW. MK. IA1	75 - 14 - 231	26.88"	95.38	15.210	6.080"	80 X 10.8 00			12,168.00	38	41"	30,400	462,384	23"
155 M.M. HOW. M. 102	75 - 14 - 232	26.79"	93.88	15.560	6.080"	80 X 10.8 00			12,448.00	38	41.5"	30,400	473,024	15"
8" GUN B. HOW.	75 - 4 - 23	31.00"	197.75	29.902	8.000"	60 X 8.8 480			14,352.96	33	48"	15,840	473,647.68	12"
240 M.M. HOW. MK. III	75 - 14 - 139	37.44"	344.85	49.492	9.425"	51 X 7.3 357			17,668.64	27	59.5"	9,639	477,053.38	13"
10" GUN MK. IV	75 - 9 - 16	43.93"	518.00	73.742	10.000"	48 X 5.2 240			17,698.08	25	59.5"	6,000	442,452	29"

THE ABOVE TABLE IS BASED ON THE STANDARD MAGAZINE, 48 FEET BY 217 FEET.

THE ABOVE TABLE IS FOR SHELL LOADED WITH T.N.T. OR AMATOL. SHELL LOADED WITH EXPLOSIVE "D" MAY BE PILED IN THE SAME MANNER, BUT AISLE SPACES NEED ONLY BE SUFFICIENT FOR INSPECTION AND HANDLING.

THE DISTANCES BETWEEN PILES ARE DESIGNED TO LIMIT EXPLOSIONS TO ONE PILE.

CAUTION - SEE ORDNANCE SAFETY MANUAL O O FORM 7224 AND ORDNANCE DEPARTMENT DRAWING 19-48-12 FOR OTHER ESSENTIAL DETAILS.

TYPICAL METHOD OF PILING

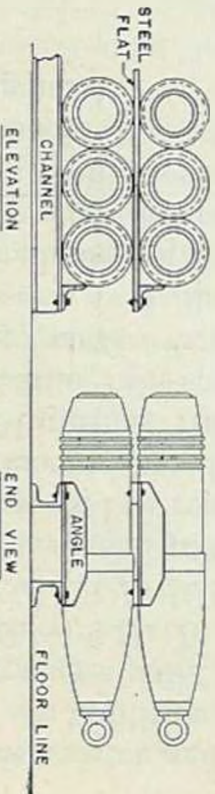

SEE DRAWING NO. 19-48-13 FOR DUNNAGE DETAILS

RA PD 4320

Figure 63.—Piling and storage data for separate loading and unloading projectiles.

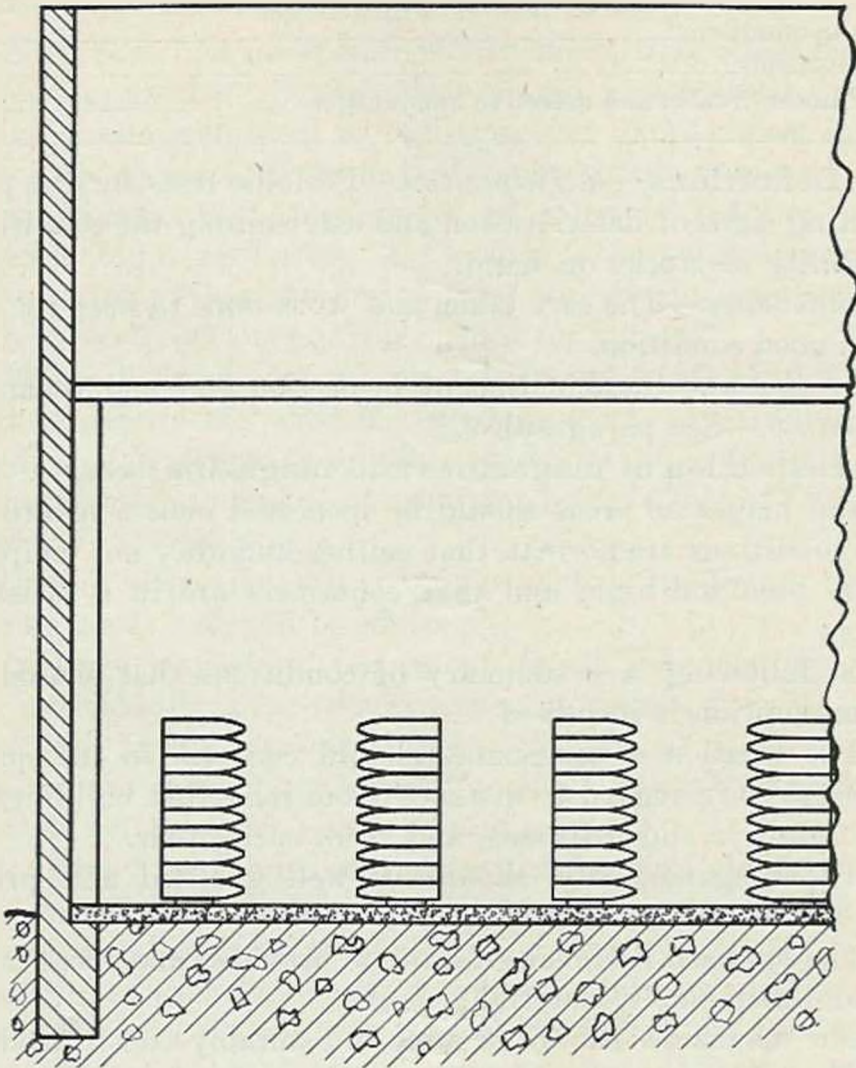

FIGURE 64.—Method of piling shell.

RA PD 4028

### SECTION III

## INSPECTION AND SURVEILLANCE

	Paragraph
Definitions .....	119
Inspection of magazines and magazines areas.....	120
Smokeless powder.....	121
Fixed and semifixed ammunition and grenades.....	122
Small-arms ammunition.....	123
Bulk explosives.....	124
Separate loading shell.....	125
Bombs.....	126
Fuzes.....	127
Pyrotechnics.....	128

	Paragraph
Chemical ammunition.....	129
Inert components.....	130
Report of unserviceable and defective ammunition.....	131
Publication file.....	132

119. **Definitions.**—*a. Inspection.*—Periodic tests for the purpose of detecting signs of deterioration and determining the condition and serviceability of stocks on hand.

*b. Maintenance.*—The care taken and work done to keep the ammunition in good condition.

*c. Surveillance.*—Combination of inspection and maintenance.

*d. Grading.*—See paragraph 9.

120. **Inspection of magazines and magazine areas.**—*a.* Magazines and magazine areas should be inspected once a month to see that all conditions are normal, that neither humidity nor temperature is or has been too high, and that containers are in a satisfactory condition.

*b.* The following is a summary of conditions that should apply when ammunition is inspected:

(1) The location of magazines should conform to the quantity-distance tables in regard to distance from inhabited buildings, from public highways and railroads, and from each other.

(2) The magazine area should be well guarded and protected against fire.

(3) The required firebreaks should be provided and free from rubbish and inflammable material.

(4) The magazines should be well and suitably constructed.

(5) The magazines should be in good repair, dry, and well ventilated.

(6) The interiors of magazines should be clean and neat with stores arranged in orderly piles.

(7) The requirements of the storage chart, paragraph 117, should be met.

(8) The stores should be properly identified by lot number and piled with no more than one lot in each pile.

(9) Boxes should be securely closed.

(10) Loose rounds, damaged containers, empty containers, paint, oil, waste, rags, tools, and other prohibited articles should not be present in the magazine.

(11) All ammunition, explosives, and loaded components (except small-arms ammunition) should be stored in segregated magazines and not in buildings used for other purposes.

(12) Files of pertinent publications should be on hand and up-to-date.

121. **Smokeless powder.**—*a.* Smokeless powder in bulk and sep-

arate loading propelling charges should be inspected to see that all containers have lids fastened firmly in place, that containers are airtight and in good condition. They should be examined for evidence of having been subjected to moisture and dampness and, in warm weather and climates, the records of the maximum-minimum thermometer examined. Metal containers of separate loading propelling charges should be air tested. Air testing personnel should be familiar with the odor of decomposing powder and should note carefully the odor from each container as it is opened for air test.

*b.* When smokeless powder reaches an age at which it may be expected to deteriorate with increased rapidity, each container is inspected at least every 12 months. Methods of inspection and tests to be performed are laid down each year by the Chief of Ordnance and published in OFSB 3-13.

*c.* During inspection, minor repairs such as tightening lacings and replacing gaskets should be effected.

*d.* In large magazines, instead of dating each methyl violet test paper individually, a record may be kept in the magazine of the date of inspection. If any lots containing such undated papers are shipped elsewhere, the date of last inspection which normally appears on the test paper will be shown on the shipping ticket.

**122. Fixed and semifixed ammunition and grenades.**—*a.* All stocks on hand should be inspected to see that they can be readily identified as to kind and lot number and that the ammunition has not been subjected to moisture and dampness. Boxes should be examined to see that they have not been opened nor individual rounds removed from their sealed containers. Serviceable rounds turned in by troops should be examined to see that they have been properly repacked and sealed. Unserviceable rounds on hand should be examined to see that they are packed in closed boxes and inquiry made to ascertain that they have been reported for disposition.

*b.* Representative rounds of lots that have been in storage for more than 1 year should be examined as described below.

(1) One round of ammunition will be selected at random from each of three packages representative of each lot. These rounds should be removed from the magazine and disassembled with care. Immediately after the shell is removed from the cartridge case, the odor from the powder will be noted. All instances of the odor of nitrous fumes will be reported.

(2) Pour out the powder into a separate pile for each round and inspect for deteriorated grains. The most common indication of deteriorated grains is the appearance of reddish yellow spots which gradually spread over the grain until the entire grain is the same

color. This orange-colored section is brittle and friable and has a dull surface. There is another type of deteriorated grain having a reddish, translucent, waxy appearance; however, this type should not be confused with the normal amber-colored grain which is characteristic of some lots of smokeless powder. In general, any charge containing an excess of 1 percent deteriorated grains will have a marked odor of nitrous fumes.

(3) If no deteriorated grains are present, the round will be reassembled.

(4) If deteriorated grains are present, the percentage will be determined and reported independently for each round of the sample. If the percentage is in excess of 1 percent, a similar determination of percentage of deteriorated grains will be made in nine additional rounds.

(5) If the percentage of deteriorated grains does not exceed 1 percent, the round will be reassembled; if over 1 percent the smokeless powder from that round will be destroyed, the primer fired, and the balance of the round shipped to the nearest ordnance depot.

(6) Since it is very difficult to discern deteriorated grains in graphited, FNH, or NH powders, rounds containing such powders will be tested for odor only. If acid odor is detected the round will be disposed of as indicated in (5) above for deterioration above 1 percent.

(7) Semifixed ammunition will be inspected as described above except that, when the charge is contained in bags, the bags only will be inspected for orange or brown spots or total discoloration. Rounds containing bags which are discolored or spotted due to deteriorated smokeless powder will be disposed of as described above for deterioration above 1 percent.

(8) Propelling charges of 3-inch mortar shell will be examined for ability to stand assembly to the shell. The samples taken should be three cans from each lot and, if unsatisfactory, an additional 1 percent of the lot on hand.

(9) Mortar shell and grenades are inspected as in *a* above except that extreme care is taken to see that all grenades and grenade fuzes are in boxes which are so effectively closed that the articles cannot be easily removed and handled.

(10) A report in duplicate for each lot inspected will be forwarded, through channels, to the Chief of Ordnance.

**123. Small-arms ammunition.**—TM 9-1990 and OFSB 3-5 should be at hand.

*a.* An examination should be made to see—

(1) That all ammunition on hand is properly identified.

(2) That box seals have not been broken or liners opened.

(3) That covers of partly filled boxes are firmly fastened.

(4) That an excessive quantity of grade 3 ammunition has not accumulated.

(5) That grade 3 ammunition has been reported.

(6) That there is no great accumulation of serviceable rounds of ammunition not packed in clips or bandoleers or in the regularly prescribed manner.

(7) That there is no accumulation of otherwise serviceable ammunition not identified by lot number.

*b.* Ammunition that has been in storage for 1 year should be inspected for corrosion, season cracking, dents, or other defects of the cartridge case, and for loose bullets or split tracer bullets.

*c.* Serious defects should be reported at once and if the number of defective cartridges is greater than 20 percent, the lot should be held for instructions from the Chief of Ordnance.

**124. Bulk explosives.**—Black powder in bulk, practice bomb and smoke-puff charges, TNT in bulk and blocks, explosive D, and dynamite should be examined to see that the containers are in good condition, that there are no open containers, and that explosives are not sifting from the containers. Black powder containers should be examined for rust and for evidence that containers have been opened in an improper manner, such as by the use of a cold chisel, hatchet, or other unsuitable tool. Dynamite containers should be examined for signs of exudation and other evidence of nitroglycerin on the case or on the floor.

**125. Separate loading shell.**—*a.* Separate and unfixed shell should be inspected to see that they are piled in the manner, and with the clearance, prescribed in these regulations. Shell should be inspected for rust or corrosion and some of the fuze hole plugs should be removed to see that the threads are not burred or rusty and that the cavity is clear. Bands should be protected against dents, cuts, and pressure from upper layers of shell. Shell should be examined to see that they are properly painted and marked as required. TNT or amatol shell should be examined for exudate. Any exudate formed on shell or the floor should be scrubbed up with hot water. Exuding shell should be reported and held for disposition. Exudate is an oily brown liquid that oozes out around the thread in the nose of a shell. It is inflammable and may carry small particles of TNT. If the exudation is slight, the corps area or department ordnance officer may permit the shell to be used after the exudate has been thoroughly cleaned off. If the exudation is excessive and drips on the other shell or the floor, the shell will not be used. Exudate should be cleaned from the projectiles and from the floor by scrubbing with hot water.

b. When it becomes necessary to recondition the exterior surfaces of projectiles, they should first be thoroughly cleaned. Metal does not stop rusting unless all signs of rust are removed from the shell. Light engine oil should be applied and cleaned off with gasoline after 2 or 3 weeks; then paint, with one coat of primer and one, or two if necessary, coats of paint. If shells are stored in damp places, district commanders may authorize the use of grease for slushing after painting or may dispense with painting entirely if, under local conditions, adequate protection can be obtained through the use of grease alone. It must be remembered that in warm weather grease must be renewed frequently. Whether painted or greased or both, provision must be made for stenciling lot numbers and other identifying marks on projectiles and storing them so that the shell may be readily identified by lot number.

**126. Bombs.**—The requirements for the inspection of fragmentation bombs are similar to those for fixed ammunition. Demolition bombs are inspected to see that the regulations laid down for storage are strictly complied with. Examination should be made for exudate, rust, and corrosion. Fin assemblies should be protected. Fuze hole plugs should be removed from a representative sample to see that threads and cavities are in good condition. Painting and marking should be in accordance with regulations. Exuding bombs are treated the same as exuding shells.

**127. Fuzes.**—Fuzes and other small loaded components should be examined to see that they are stored in sealed containers and well protected against moisture. Partly filled boxes are examined to see that they have been properly resealed. A check should be made to see that the components are suitable for use with the ammunition on hand and that the required number is available. Components which have been in storage more than 1 year will have a representative box of each lot opened and the contents examined for rust, discoloration, and corrosion. Satisfactory items are resealed by resoldering containers or sealing with friction tape and a coat of shellac. Questionable items will not be issued but will be reported to the Chief of Ordnance for disposition.

**128. Pyrotechnics.**—Pyrotechnics should be examined to see that all containers are in good condition, and that they are effectively closed so that the contents cannot be easily removed or handled. Some pyrotechnics have a definite date of expiration of service life marked on the package. This date should be checked and OFSB 3-9 should be consulted for disposition of overage material.

**129. Chemical ammunition.**—Chemical ammunition should be inspected to see that it is stored so that any leaky container can be readily removed and that facilities for handling leaky containers are

available. The ammunition is examined monthly for leaks and every 6 months for rust or corrosion. Boxes should be examined to see if there are any instructions thereon requiring the destruction or use of the contents by a certain date. Containers which develop leaks should be reported, through channels, to the Chief of Ordnance. Such reports should include information as to type, lot, date discovered, nature of leak and whether apparently caused by defective material or improper handling, and disposition made of container or disposition recommended.

**130. Inert components.**—Inert or empty components of ammunition should be inspected to see that they are properly protected against rust and corrosion, or if they need a renewal of a protective coating of paint or grease.

**131. Report of unserviceable and defective ammunition.**—  
*a.* When the material in the hands of troops is inspected, inquiry should be made as to any ammunition failures experienced since the date of the last inspection and whether such failures have been reported. If no report has been made through channels to the Chief of Ordnance, all available details of failures will be collected and so reported.

*b.* If the inspector finds defects in ammunition which will require the expenditure of labor or funds to correct, he should take care to examine a sufficient number of containers or rounds to insure a report on average conditions and not isolated cases. The examination of five containers, selected at random, should be sufficient for a report that will reflect average conditions.

**132. Publication file.**—A file of pertinent Technical Regulations, Technical Manuals, Field Manuals, and Ordnance Field Service Bulletins will be kept complete and up-to-date. The corps area or department ordnance officer or his assistant should determine, when inspecting ammunition at a post, camp, or station, that such files are available and their contents are thoroughly understood.

## SECTION IV

### PACKING AND MARKING

	Paragraph
General .....	133
Packings .....	134
Regulations .....	135
Sealing .....	136
Marking .....	137
Lot number .....	138
Data card .....	139

**133. General.**—*a. Purpose of packing.*—(1) In order that ammunition may reach the firing line in a serviceable condition, it is



essential that each unit of issue be suitably packed to withstand handling, storage, and transportation. Once a unit of ammunition has been removed from its approved container, there is no assurance of its continued serviceability. Therefore, equal precautions should be taken in its further handling and storage.

(2) When a waterproof container is opened, the contents are immediately subject to the effects of moisture, which is the most active agent in causing the deterioration of ammunition. In case immediate use is not contemplated, steps should be taken to reseal the container.

*b. Marking.*—(1) Marking includes painting, stenciling, and stamping of containers and of the ammunition itself. (See par. 8.)

(2) Explosives and other dangerous articles offered for shipment on a common carrier will be marked to comply with Interstate Commerce Commission regulations.

(3) Explosives and ammunition will be marked in accordance with Army Regulations, specifications, and drawings. Standard and special markings are covered by U. S. Army specification 100-2, and are further described and explained in Technical Manuals and in other sections of this manual. Markings furnish essential information, permitting intelligent handling, storage, and issue of the round or component.

(4) New painting or remarking of ammunition and ammunition components should be a facsimile of that of the original container or ammunition unless the Chief of Ordnance issues specific instructions to the contrary. Explosives and ammunition obtained from salvage operations or matériel whose identification has been lost should be marked to show clearly the nature of the goods and, if offered for shipment, will be marked to comply with Interstate Commerce Commission regulations.

**134. Packings.**—*a. Design and construction.*—The design and construction of packings depend upon the type of hazard involved and the facilities for storage and transportation, and the type of protection required by the item packed.

*b. Types.*—(1) *General.*—Wooden boxes and crates are used more often than other types. The trend being followed in the design of boxes and crates is toward the use of standard 1-inch, or heavier, lumber. However, recently boxes of wire-bound construction using a veneer with reinforcing cleats, with strands of wire encircling the box, have been adopted as standard in several instances. Wire-bound boxes will not stand as much reuse as the heavier wooden box but their original lower cost will probably make their use more economical, particularly at times when reuse of the box would not be warranted. Corrugated or fiberboard containers are to some extent replacing the

wooden packing boxes, as in the case of some complete rounds, propelling charges, and pyrotechnics. Four general types of packing—boxes, crates, cartridge storage cases, and fiber containers—are noted below.

(2) *Boxes.*—(a) *End opening.*—One end being removable, these boxes can be stacked on their sides, permitting opening without necessity of removal from the stacked pile.

(b) *Chest type or hinged top.*—This type provides easy access to the contents and repeated use.

(c) *Screw top.*—This type uses screws, or bolts and nuts, to hold down the top cover. Boxes for fuzes, primers, boosters, and primer detonators should have their wooden covers fastened with screws. Nails will not be used.

(3) *Crates.*—These are used for crating bombs, projectiles, components, and metal powder containers to give added strength and protection, and where packing in a closed box is not necessary. Metal crates, of steel, are used entirely in the shipment of some bombs. Other crates are wooden.

(4) *Cartridge storage cases.*—These are made of fiber or metal, are cylindrical, moistureproof, airtight, and are used for packing propelling charges for separate loading ammunition.

(5) *Fiber containers.*—A slip-cover fiber container of the mailing tube type is used for the packing of complete rounds, of separate loading propelling charges for artillery weapons, of hand grenades, of assemblies of boosters and fuzes, of fuzes, etc. These fiber containers are usually shipped in bundles of three, by means of two cup-shaped cloverleaf-design metal end-covers. An automatic U-shaped packing stop is used in fiber containers for fuzed projectiles.

(6) *Miscellaneous.*—(a) Metal cans, of terneplate or tin plate, are used for packing small components of ammunition individually or in small quantities, to preserve them against moisture. Metal liners for wooden boxes are also used in many types of packing of components, in certain cases for small caliber complete rounds where a moisture-proof container is desired, or for shipments of smokeless powder. Zinc-lined wooden boxes are used for storage of all cannon powders having a web less than .019 and compositions other than the nitrocellulose type.

(b) All-steel boxes of Navy design are used for storing all cannon powders having a web of .019 and greater. Sheet steel cylindrical drums are used for black powder, which is contained in a cloth bag inside the drum. The drums are crated for oversea shipments.

(c) Fiber cartons are used for packing primers or small fuzes, a small number being packed in each carton. Where it is desired to

render the carton moistureproof, it is usually immersed in hot paraffin.

**135. Regulations.**—*a.* The general regulations governing the packing, marking, and shipping of military supplies are set forth in AR 30-955.

*b.* Explosives and other dangerous articles offered for shipment on a common carrier will be packed to comply with Interstate Commerce Commission regulations, but paragraph 14 (a), section I, of these regulations states that “shipments of explosives offered by or consigned to the War and Navy Departments of the United States Government must be packed, including limitations of weight, in accordance with these regulations or as required by their regulations.” Any proposed departure from the requirements of Interstate Commerce Commission regulations must be submitted to the Chief of Ordnance for decision.

*c.* Military explosives and ammunition are packed in accordance with U. S. Army specifications and drawings. The methods of packing specified and used not only meet military requirements and protect the articles from damage in transit but are also designed to comply with Interstate Commerce Commission regulations.

*d.* When shipments of explosives and other dangerous articles are to be made and containers are not available which comply with U. S. Army specifications for the particular article to be shipped, containers complying with Interstate Commerce Commission regulations will be used. This applies particularly to the shipment of deteriorated explosives or ammunition and to powder, explosives, and loaded components of ammunition obtained from salvage operations.

*e.* Other sources of regulations concerning packing will be found in the various Technical Manuals and Regulations, Standard Nomenclature Lists, Ordnance Field Service Bulletins of Series 3, Ordnance Safety Manual O. O. 7224, AR 30-1270 (shipments by water), and U. S. Army specification 49.0-7 (general packing specifications).

**136. Sealing.**—Packings are sealed for airtightness by closing the test hole of airtight cartons, containers, or cases with solder or a plug. Each container, after the contents are properly packed, is sealed in some manner which will indicate whether or not the container has been tampered with. The method of sealing depends upon the type and construction of the container. Where metal strapping is used around boxes, paper seals are not necessary and will not be used in the future.

**137. Marking.**—*a. On ammunition items.*—(1) As few markings as possible for positive identification are used on ammunition and its components. Such items as caliber and type, model or mark number, zone marking, lot number, year of loading, and initials or symbols of loading plant are stenciled on ammunition and its components. Colors

are used to indicate the type of ammunition. In general, two systems of color markings are employed, one for small-arms ammunition and the other for all other types of ammunition, including artillery and mortar ammunition, bombs, grenades, mines, and pyrotechnics.

(2) Armor-piercing cartridges are identified by the blackened point of the bullet. Tracer cartridges are identified by the colored lacquer or stain on the point of the bullet. Otherwise, small-arms ammunition is distinguished by the colored bands marked on the packing boxes which are listed in paragraph 57.

(3) (a) Whereas small-arms ammunition is not marked by painting, except in tracer and armor-piercing cartridge type, all other ammunition is painted or indicated as to the type of filler according to the basic color scheme.

(b) Igniters for propelling charges and primer-detonators for bombs are located by a red mark on the packing.

(c) In complete rounds in which two alternative complete propelling charges are provided, the propelling charge bag for inner zones is dyed green; that for outer zones is white.

(4) For other markings on ammunition, see previous sections of this manual and other Technical Manuals on ammunition.

*b. On containers.*—(1) AR 30-955 contains general regulations governing the marking and shipping of military supplies. AR 30-1270 contains regulations on packages to be shipped by water and also a list of shipping names; a compilation of such a list of shipping names will be found in OFSB 3-12. U. S. Specification 100-2 also contains regulations for marking containers.

(2) With certain exceptions given in AR 30-955, each package of supplies turned over for shipment on a Government bill of lading is marked with—

- (a) Name and address of consignee.
- (b) List and description of contents.
- (c) Gross weight in pounds, displacement in cubic feet.
- (d) The number of the package.
- (e) The letters "U. S. W. D." in several conspicuous places.
- (f) Order number, contract number, or shipping number.
- (g) Ordnance insignium and escutcheon.
- (h) Name or designation of consignor preceded by word "From."
- (i) Lot number.
- (j) Month and year packed.
- (k) Inspector's stamp.

(3) Markings on boxes, barrels, or crates are made in stencil black or stencil white, whichever is more appropriate. In case of small-arms ammunition, where the box is painted brown, the marking is in yellow.

When it is impractical to stencil or paint the markings on the containers, or whenever a container is not used in shipping, at least two shipping tags bearing markings should be used. The shipping tags may be of cloth, leather, metal, or waterproof paper, the tags being attached to the article by wire. The use of writing ink, chalk, or marking material other than waterproof ink or paint is prohibited.

(4) The use of certain conspicuous and distinctive labels is required by the regulations for containers. They are furnished, on requisition, by The Quartermaster General and must be attached before delivery to the carrier.

(5) Often the color distinguishing a particular kind of ammunition is also indicated on the box or container. Boxes or containers for green bag propelling charge, white bag propelling charge, or section of propelling charge containing the black powder igniter, are painted with green, white, and red stripes, respectively. Boxes for bombs are painted with stripes around the center and on each end according to the color scheme in paragraph 8. The adhesive sealing strip on fiber containers containing complete rounds of low explosive mortar ammunition or shrapnel is colored red to indicate the presence of black powder; that on containers of HE shell is yellow.

(6) Before issue of small-arms ammunition, it must be identified by type and lot number from the labels of the original packages. Colored bands, painted on the sides and ends of the packing boxes, identify the various types of small-arms ammunition. The color bands used are listed in paragraph 57.

**138. Lot number.**—*a.* An important part of the marking for military explosives and ammunition is the lot number. The lot number will always appear on the containers and data cards and whenever possible on the ammunition itself.

*b.* Lot numbers consist of letters and figures which represent the initials of the manufacturer or loading company, the number of the War Department procurement order, the serial number of the lot, and in some case the date. Variations from this general scheme will be noted, since it is not practicable to use the same system of lot numbering for all kinds of explosives and ammunition.

*c.* The identification of military explosives and ammunition by lot number is essential for surveillance. It is the means by which stocks are conserved or utilized to the best advantage, and defective or deteriorated ammunition is withdrawn from service. It is also used in selecting ammunition for issue, because the ballistics or performance of ammunition when fired may vary from lot to lot. See discussion of lot numbers in paragraph 7.

**139. Data card.**—The data card gives all the necessary informa-

tion for proper and complete identification of the item or component. Data cards are prescribed for use with all items of ammunition containing explosives, except explosives in bulk. They are usually required by specifications for nonexplosive materials procured for use with ammunition. The 5- by 8-inch data card is placed in every box (two in metal-lined boxes, one inside and one outside the liner) and one attached to every crate or large item inclosed in a crate. Externally attached cards, which might be exposed to the weather, are inclosed in a waterproof envelope. Ammunition data cards are prepared in quadruplicate for each lot of loaded projectiles. The preparation and distribution of ammunition data cards will be found in OFSB 3-2. In the case of separate loading propelling charges, a linen tag containing similar data is attached to the charge in lieu of a data card.

## SECTION V

## SHIPPING

	Paragraph
General-----	140
Regulations and references on transportation-----	141
Rail shipments-----	142
Water shipments-----	143
Motor truck shipments-----	144

**140. General.**—This section contains special regulations for the shipping and transportation of explosives and ammunition. The general regulations are contained in AR 30-955.

**141. Regulations and references on transportation.**—*a. Compliance with laws and regulations.*—Shipments of explosives and ammunition made by Military Establishments will comply with Interstate Commerce Commission regulations, port and harbor regulations, State and municipal laws, and Bureau of Explosives recommendations. Difficulties encountered in complying with the above will be reported in detail, through channels, to the Chief of Ordnance.

*b. Interstate Commerce Commission regulations.*—(1) The transportation of explosives and other dangerous articles within the limits of the jurisdiction of the United States is regulated by Federal law, act of March 4, 1909, chapter 321, sections 232 and 234 (35 S. 1134), as amended by the act of March 4, 1921, chapter 172 (41 S. 1444-1445), and the Dangerous Cargo Act of October 9, 1940 (Public No. 809, 76th Cong.).

(2) Section 233 of the above-mentioned act reads as follows:

The Interstate Commerce Commission shall formulate regulations for the safe transportation, within the limits of the jurisdiction of the United States, of explosives and other dangerous articles, \* \* \*

which shall be binding upon all common carriers engaged in interstate or foreign commerce which transport explosives or other dangerous articles by land or water, and upon all shippers making shipments of explosives or other dangerous articles via any common carrier engaged in interstate or foreign commerce by land or water.

(3) Section 235 of the act of March 4, 1921, requires the shipper of explosives and other dangerous articles to describe, pack, and mark his packages properly, and to inform the agent of the carrier in advance of the true nature of their contents.

(4) Section 232 of the act of March 4, 1921, provides that it shall be unlawful to transport certain explosives on any car or vehicle of any description operated in the transportation of passengers by a common carrier engaged in interstate or foreign commerce, which car or vehicle is carrying passengers for hire.

(5) The Interstate Commerce Commission Tariffs No. 3 and No. 4 contain the regulations for the transportation of explosives and other dangerous articles by water on freight and freight-and-passenger vessels and by land on freight, express, and baggage rail services, respectively. They are also known as Agent W. S. Topping's Freight Tariffs Nos. 3 and 4. Supplements and reissues are published from time to time. The regulations governing the transportation of explosives and other dangerous articles by motor vehicle on highways are published in Interstate Commerce Commission Motor Carrier Safety Regulations, Revised, Part 7.

*c. Bureau of Explosives.*—Section I, paragraph 5, of the Interstate Commerce Commission regulations covering shipments of explosives and other dangerous articles by rail, reads as follows:

The service of the bureau for the safe transportation of explosives and other dangerous articles, hereinafter called Bureau of Explosives, will be utilized by this commission in the execution of these regulations. This bureau will make inspections and conduct investigations, and will confer with manufacturers and shippers with a view to determining what regulations will within reasonable limits afford the highest degree of safety in packing and preparing these dangerous articles for shipment and in transporting the same. The commission will avail itself of the expert knowledge thus developed, and in formulating amendments to these regulations, while not bound thereby, will give due weight to the expert opinions thus obtained.

The Bureau of Explosives was organized in 1906 by the American Railway Association. Nearly all common carriers are members of the American Railway Association and comply with the rules and regulations issued by the Bureau of Explosives. Inspectors of the Bureau of Explosives are stationed throughout the country to observe, investigate, and report upon shipping methods, and common

carriers utilize the services of the inspectors of the Bureau of Explosives to enforce regulations, to approve methods and practices, and to assist shippers. The name and address of the nearest Bureau of Explosives inspector can be obtained from the local railroad agent, or by writing to the Bureau of Explosives, 30 Vesey Street, New York City.

*d. State and municipal laws, ordinances, and regulations.*—In addition to the Federal laws governing interstate transportation of explosives and other dangerous articles, each State and nearly all municipalities have laws or ordinances regulating the transportation of explosives and other dangerous articles within their jurisdiction. The harbor regulations of the port of New York or port of Baltimore and city ordinances requiring motortrucks or wagons carrying explosives to display a red flag of placard are examples of such State and municipal laws and ordinances.

**142. Rail shipments.**—*a.* The Interstate Commerce Commission regulations which govern the transportation of explosives and other dangerous articles by rail are essentially safety regulations and describe in detail how such shipments will be handled, loaded, braced, and stayed, and placarded. (See also AR 30-955.) Bureau of Explosives Pamphlet No. 6 contains data, photographs, and drawings of recommended methods of bracing and staying shipments. These recommendations, although for commercial explosives and other dangerous articles, can be readily adapted to military explosives and ammunition, and will be followed when a method such as that set forth in U. S. Army Specification No. 50-21-4 is not prescribed. See figure 65 for a method of packing projectiles in freight cars.

*b.* When making shipments of explosives and ammunition by rail, Bureau of Explosives pamphlets should be consulted for ideas as to piling and packing, and Interstate Commerce Commission regulations for information as to legal requirements. The cargo should be studied and decision made beforehand how it may best be stowed. The car best suited for the needs at hand should be ordered. When the car arrives, it should be given a thorough sweeping and inspected for protruding nails and bolt heads, which must be removed or covered with wood. The sides of the car should be boarded up where necessary to obtain an even bearing and proper dunnage (see Bureau of Explosives pamphlets). Substantial gangways should be provided; obstructions which may prevent free entry to the car removed; the immediate vicinity cleared of leaves, dry grass, and other inflammable materials; and the brakes set and wheels chocked. During loading operations, the car and magazine doors should be closed



when engines or speeders are passing. Cars should not be left partly loaded, unless impossible to finish loading at one time, in which case car doors must be securely locked. After loading, the shipment should be properly braced and stayed, the car properly sealed and placarded, and a permanent record of car numbers kept. In unloading cars the same safety precautions that have been outlined above should be observed. All cars that have contained explosives should be carefully swept and all placards removed. Sweepings should be thrown in running water, burned, or placed in a metal receptacle for later disposition. All shipments received in a badly damaged condition should be reported through channels to the Chief of Ordnance.

*c.* Interstate Commerce Commission regulations require the use of a "certified car" for shipment of explosives. A "car certificate" must be signed in triplicate by a representative of the carrier and of the shipper after the shipment is loaded and properly braced. Two of these must be attached outside of the car doors or to the sides of the car, one on each side, in addition to any explosives placards.

*d.* Dangerous explosives must not be transported in any self-propelled car operated by electric or other motive power if such car is carrying passengers.

*e.* Loaded railroad cars will not be left in the open area between magazines, as they may act as an intermediate step in propagating an explosion.

**143. Water shipments.**—*a.* Interstate Commerce Commission Freight Tariff No. 3 prescribes regulations for the transportation of explosives and other dangerous articles by water on freight and freight-and-passenger vessels. Other regulations that apply are port and harbor regulations of the various cities and States affected and regulations of the carrier, usually the Quartermaster Corps or the Navy Department.

*b.* When shipments of explosives and ammunition are made by water, the local port regulations regarding the handling of explosives should be studied and the regulations for tonnage, lights, open fires, stoves, mixed loads, flags, anchors, etc., complied with. When equipment for shipments is chartered, the equipment should be passed upon by port authorities before it is accepted for use. During loading, the safety regulations for open fires, stoves, gasoline, matches, smoking, etc., will be strictly complied with; decks, runways, and docks should be free from dirt, rubbish, and spilled explosives; and personnel should handle explosives and ammunition with care so as to avoid danger and damage to the shipment. If the loading is not completed during the day, proper precautions will be taken to guard and protect the shipment against fire and a sufficient crew will be left in charge to

handle the boat in case of emergency. Explosives or ammunition should not be left on a dock or elsewhere unless delivery is made to authorized persons or explosives left under proper guard. Explosives and ammunition must not be left on board boats overnight unless such action is imperative incident to their transportation. Lighters should not be tied up to that part of a vessel or dock where the fireroom or boiler is located. Explosives should be kept as far away from engine and boiler room as possible.

*c.* The use of oil- or chemical-burning lamps or lanterns is prohibited in the neighborhood of explosives. Only electric lanterns will be used when a movable artificial light is necessary. In port and starboard lights and other such necessary signals, oil-burning lights are permitted; these should be placed, removed, and filled by a responsible officer, who should see that they are not brought in contact with explosives or do not introduce fire risk to the boat or barge. Storage of paints, oils, varnishes, or other inflammables is prohibited on any boat or barge used for explosives or ammunition. Such oil as is necessary in connection with the machinery of a boat must be kept under the direct charge of the chief engineer, and only a day-to-day stock permitted. Oils used for signal lights and in living quarters must be kept under lock and key, and should be in direct charge of the officer in charge of the lights. Oil must not be put in or removed from this compartment at night. If oil accidentally gets on the floor, it must be immediately swept up with sawdust and the sweepings thrown overboard.

*d.* No explosive will be placed on board any vessel until all the other cargo has been placed aboard. As far as is practicable, the necessary work in the construction of floors, magazines, partitions, etc., or for the removal of any combustibles from that part of the hold in which explosives are to be stowed, should be completed before loading of the explosives is commenced. All rubbish, shovelings, old oil, paint cans, oily rags, rope ends, etc., must be cleared out of the hold. Floors must be kept broom clean. All decks, gangways, and holds over which explosives must be passed in loading must be freed from all loose metals or tools, and carefully swept before loading is commenced and after loading has ceased.

*e.* The hatches of the vessel will be kept closed except during the loading and unloading of the vessel, and when so closed will be covered with tarpaulin battened.

*f.* Lighters, barges, scows, and all tugs engaged in hauling vessels loaded with explosives must have their funnels or smoke stacks covered with screening of suitable size to prevent the exhaust of sparks and this screening must be renewed whenever it is broken.

*g.* Magazines (cargo space) for explosives must be lined entirely with wood not less than 1 inch thick, nailed with cement-coated nails with heads countersunk. Metal obstructions or constructions within the area of the magazine must be entirely covered with wood, nailed as mentioned above.

*h.* Explosives awaiting removal or delivery must be stored outside the dock or wharf when practicable and every possible effort must be made to reduce the time of this storage. Explosives held for delivery or loading must be in a safe place, and away from other dangerous articles.

*i.* All packages of explosives must be handled carefully. They must not be thrown, dropped, or unnecessarily dragged, rolled over each other or over decks. Portions of metal decks or exposed metal objects and surfaces must be covered with wood, canvas, or other material that will tend to prevent the occurrence of sparks. When explosives cannot be transferred by hand or chute, transfer must be made by mechanical hoists and special crate or basket. If slings are needed, those entirely of rope will be used. Packages containing explosives must be so stowed and stayed in the lockers, compartments, or magazines of vessels that they will not shift in any direction. Broken or seriously damaged packages will not be accepted for transportation. Repacking will not be done on or near any vessel, barge, lighter, or scow having explosives on board. Any explosive that has escaped from a broken or otherwise defective package will be immediately swept up and removed to a safe place.

*j.* Transportation of explosives, except small-arms ammunition, on ships carrying passengers is prohibited.

**144. Motor truck shipments.**—*a.* Transportation of explosives and other dangerous articles by truck is covered by chapter 7, Interstate Commerce Commission Motor Carrier Regulations. Such of these regulations as are applicable will be complied with. Nearly all states, cities, towns, and villages also have laws governing the transportation of explosives and other dangerous articles within their jurisdiction. When making shipments of explosives and ammunition by motor, local civil authorities of the cities and towns through which the explosives and ammunition are to be transported should be consulted and their rules and regulations for the transportation of explosives and ammunition strictly observed. Their recommendations as to the best route to follow should be obtained so as to avoid congested areas. If compliance with these laws is manifestly impractical, then the matter will be referred to the Chief of Ordnance for decision.

*b.* Except in cases of emergency, no explosive materials or ammunition containing explosive elements, except small-arms ammunition,

will be shipped by motor truck without prior approval of the War Department. The intention is to avoid shipping by truck all types of explosives and ammunition, except small-arms ammunition, where rail or water transportation is available. However, this regulation does not apply to local or nearby hauling, delivery, or movement.

*c.* Explosives and other dangerous articles will not be shipped by any commercial highway carrier, nor will local drayage thereof by any commercial concerns be engaged, unless the carrier or drayage concern files a certificate with the quartermaster arranging for such service that said carrier or drayage concern will comply with all laws and regulations promulgated by Federal, State, and local governments and municipalities that may be applicable to and govern each particular shipment of explosives and other dangerous articles.

*d.* If shipments of explosives, toxic gases, and other dangerous articles are made by United States Government operated motor vehicles, the shipping officer will take all necessary and reasonable precautions to insure its safe transit. Except in time of emergency, the shipping officer will be responsible that all Interstate Commerce Commission regulations governing the transportation of explosives are observed. In case of emergency, so declared by any commanding officer of an arsenal or depot, or a general or field officer of the line, the shipping officer will take every reasonable precaution to insure safe movement of his cargo of explosives, toxic gases, or other dangerous articles while in transit by motor vehicle on Government reservations and on the public highways.

*e.* Every precaution against fire should be observed. Trucks should be inspected daily to see that electric wiring, lights, brakes, gasoline tanks, and lines are in good working order; the engine clean of dust and oil, and the engine pan free from accumulations of dirt and grease. The splash of oil or grease from the universal joint, transmission, or other moving parts onto the under side of footboards or body of the car should be cleaned thoroughly after each long trip or day's work. Leaking gasoline tanks or lines should be repaired immediately, and lighted cigarettes, pipes, and open lights kept away from the vicinity when filling gasoline tanks. Where necessary, safety matches may be used. They may be kept in a metal container in the tool box. Use of strike-anywhere matches is prohibited. The amount of waste in the truck should be kept to a minimum, and oily and clean waste separated. Trash should not be permitted to accumulate in the tool box. All trucks will be provided with at least one properly filled fire extinguisher. All drivers and other employees should be instructed as to the best method of extinguishing gasoline fires with Pyrene and should be impressed with the fact that in nearly all cases there is time to

extinguish a fire, as it takes an appreciable time to heat ammunition to the point where it will explode.

*f.* When explosives and ammunition are being transported by a convoy of trucks, the trucks should not become widely separated but a safe distance should be maintained between them so as to avoid danger of collision. The convoy should be stopped once each hour during the trip to inspect each truckload. Stops should not be made within or close to the limits of cities, towns, or municipalities, and in driving through towns and cities congested streets should be avoided as much as possible. A moderate speed should be maintained and the truck kept under control. A full stop is required at railroad crossings. No unauthorized person will be permitted to ride on trucks. If a truck catches fire, the other trucks will proceed to a safe distance (out of the zone of danger in case of an explosion) and guards will be posted at a distance of several hundred yards on each side of the truck to stop all traffic. If a truck breaks down and it cannot be towed to its destination by one of the other trucks, a guard of two men should be posted and the post to which the convoy is proceeding should be notified so that a truck can be dispatched at once with loading personnel to relieve the disabled truck of its load.

*g.* Fuzes or other detonating agents should not be transported with other explosives, except ammunition for cannon shipped with fuzes or boosters assembled. The load should be well braced and stayed and tarpaulins available to protect the load from the weather or from sparks from passing locomotives, etc. Explosives and ammunition should not be unloaded or piled immediately back of the exhaust. This regulation is intended to apply to bulk shipments of ammunition by motor truck and is not intended to prohibit the carrying of complete rounds of artillery ammunition, including fuzes and primers, in one vehicle by combat units. No regulations will be construed to prohibit the carrying of complete rounds of artillery ammunition, including fuzes and primers, in one vehicle by combat units.

*h.* When transporting artillery ammunition, all projectiles should be laid on the side instead of on the base and with the sides of the projectiles parallel to the side of the truck so that the projectiles will not roll back against the tail gate of the truck and damage it. If it is necessary to place more than one layer of projectiles in the truck, strips of planking should be placed over the first layer of projectiles to protect the rotating bands from becoming deformed through contact with other projectiles when the truck is in motion.

*i.* No container of explosive or other dangerous article may be accepted for transportation by a motor carrier if it is in a leaking condition, or in such a condition as to make leakage possible, except as pre-

scribed in Interstate Commerce Commission Motor Carrier Safety Regulations, Revised, Part 7. These motor vehicle regulations are subject to further limitation with respect to transportation by water, especially of leaking containers. Any package of explosives found injured or broken in transit may be repaired when this is evidently practicable and not dangerous, and must be done in accordance with the best and safest practice known or available, and at least 100 feet distant from other explosives or ammunition. When a box containing any explosive is so damaged that it cannot be repaired, it should be reinforced by stout wrapping paper and twine, placed in another strong box, and surrounded by dry fine sawdust, or dry and clean cotton waste, or elastic wads made from dry newspapers. The box cover should then be securely attached. When any package is found to be leaking or damaged and cannot be recovered, it may not be transported beyond the minimum distance necessary to reach a place where the explosive may be disposed of with safety.

*j.* The proper signals, reflections, and portable lights and reflectors must be carried by motor vehicles. All fuel tank inlets shall be equipped with a device to relieve internal pressure. Exhaust pipes will be protected by a properly constructed flame baffle. The floors of all vehicles must be tight and exposed metal on the body covered or protected with wood or other nonmetallic material. Motor trucks containing explosives will never be taken into a garage or repair shop for repairs or storage unless it is an open, sunshade garage where no open-flame lighter or burner is in use. Explosives, when possible, will be transported during daylight. When artificial lights are necessary, only approved electric lights or electric lanterns may be used.

*k.* Before any explosive is loaded into or unloaded from any motor vehicle, the engine of the vehicle must be stopped and the brakes set. For any continuous trip longer than 8 hours, the driver must be accompanied by an assistant. Every shipment of dangerous explosive will be delivered only to a person authorized to receive it, except such shipments as are placed in magazines which are immediately thereafter locked.

*l.* Loaded trucks will not be left in the open area between magazines, as they may act as an intermediate step in propagating an explosion.

*m.* Prescribed markings on motor vehicles carrying explosives or ammunition will be by means of signs or lettering on each side and the rear of the motor vehicle in letters at least 3 inches high on a background of sharply contrasting color.

*n.* Refuelings should be reduced to a minimum. The electric ignition system should be turned off and the engine stopped during the

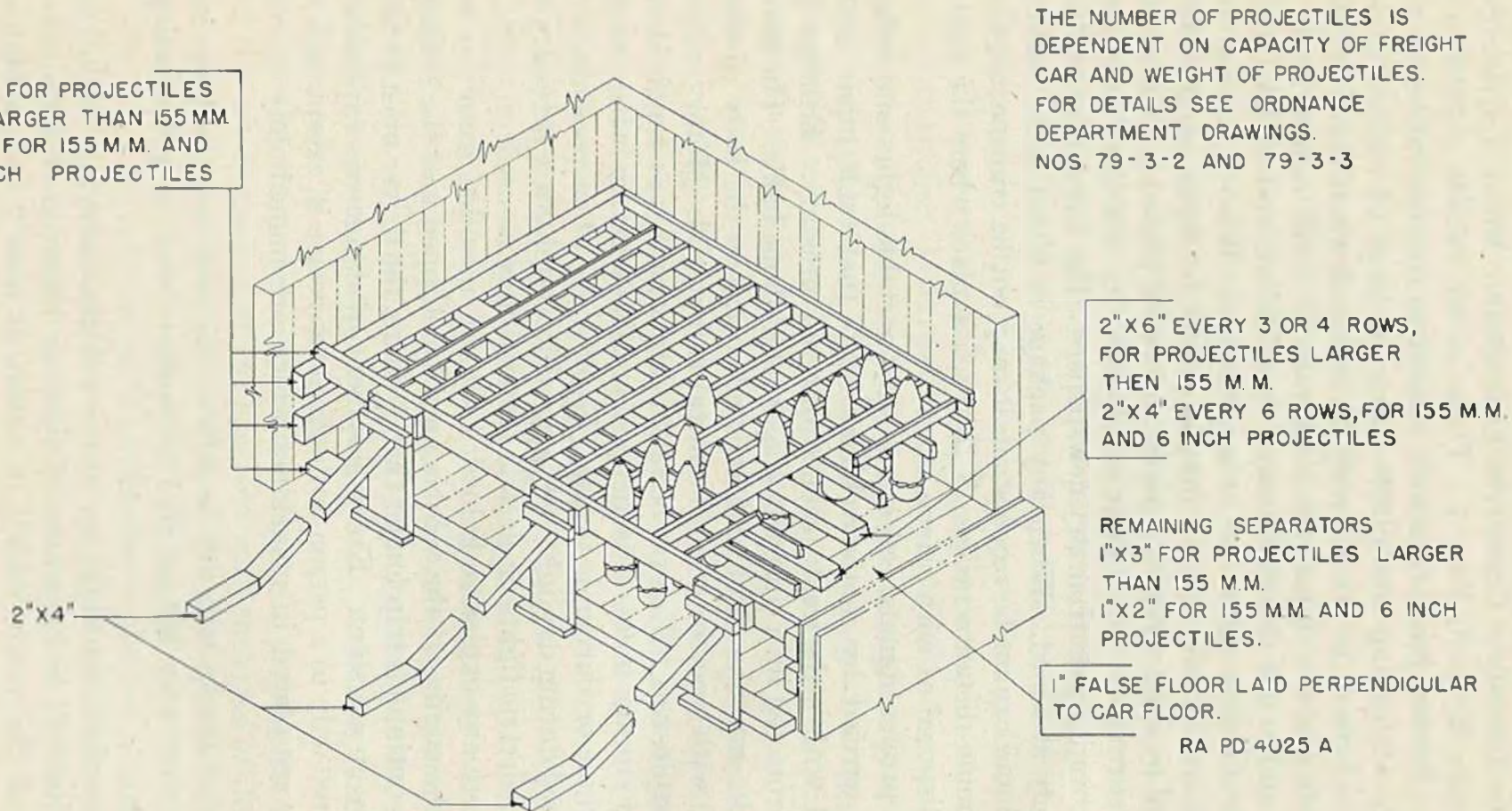

THE NUMBER OF PROJECTILES IS DEPENDENT ON CAPACITY OF FREIGHT CAR AND WEIGHT OF PROJECTILES. FOR DETAILS SEE ORDNANCE DEPARTMENT DRAWINGS. NOS 79-3-2 AND 79-3-3

FIGURE 05.—Method of stowing shell in freight car.

refueling process. If the engine is provided with a magneto, it should be grounded.

*o.* Every motor vehicle will have pneumatic tires.

*p.* In case of accident, all unbroken packages and as much of any broken packages as possible will be carefully gathered and removed to a place of safety in order to prevent fire or explosion. Care should be taken not to produce sparks. In the event that a motor vehicle is entangled with another or with an object or structure, no attempt will be made to disentangle the same, until the load is removed to a place 200 feet from the vehicle or any habitation. Inhabitants and other vehicles will be warned of danger.

## SECTION VI

### PRECAUTIONS FOR PRACTICE FIRING

	Paragraph
General .....	145
General precautions before firing.....	146
General precautions during and after firing.....	147
Small-arms ammunition.....	148
Artillery ammunition .....	149
Blank ammunition.....	150
Pyrotechnics, grenades, and chemical ammunition.....	151
Bombs.....	152
Mortar ammunition .....	153

**145. General.**—Specifications, standards, and limits of precision are prescribed for the manufacture and preparation of ammunition. In spite of this, inherent limitations exist and malfunctions of ammunition may occur. The immediate problem is to prevent the occurrence of malfunctions wherever possible, to minimize the effect when they do occur, and to profit by such experience by avoiding the same or similar malfunctions in the future. The general safety precautions, section I, should be observed wherever applicable. The regulations and precautions given in chapter 2 for the use of each type of ammunition will be observed.

**146. General precautions before firing.**—*a. Status of ammunition lots.*—A check should be made to determine the status of the lot of ammunition which it is intended to issue. Ammunition should not be fired if the lot number is not positively known. If defects which may affect the safety and functioning of the ammunition are found in a lot which is graded as being suitable for firing, a prompt report of the condition will be submitted to the corps area or department ordnance officer. Firing of that lot of ammunition will be suspended pending instructions from the proper ordnance officer. If malfunc-



tioning of the lot of ammunition occurs during firing, a prompt report will be made as prescribed in AR 45-30 and the firing of that lot will be suspended pending directions from the office of the Chief of Ordnance.

*b. Alterations and substitutions.*—Any alteration of loaded ammunition, except in accordance with specific instructions from the Chief of Ordnance, is hazardous and is therefore prohibited. Serious and fatal accidents have resulted from substitution of propelling charges, fuzes, primers, and projectiles and from the local preparation and loading of practice ammunition, including grenades, pyrotechnics, etc.

*c. Placing ammunition.*—All ammunition at the firing point will be so placed as to minimize the possibility of ignition, explosion, or detonation in case of accident at the gun position. It should be in a dry place and protected from the direct rays of the sun by tarpaulin or other covering. There should be ample circulation of air through and on all sides of the pile. Erratic ranges and dangerously high pressures may result because of overheated ammunition. White phosphorus shell will be piled away from personnel shelter and other ammunition in a space cleared of all combustible material. All components in the field should be stored separately and in small amounts so as to minimize danger from accidental burning of powder or detonation of projectiles, fuzes, and primers. Chemical ammunition is stored away from other types of ammunition.

*d. Safety zones.*—Data for delimiting safety zones for ranges in firing small arms, artillery weapons, and chemical warfare weapons will be found in AR 750-10.

*e. Smoking.*—Smoking by anyone handling, or in the vicinity of, explosives or ammunition is prohibited.

*f. Lights.*—Use of any lights, other than approved lanterns or flashlights, in the vicinity of explosives or ammunition is prohibited.

*g. Handling.*—Care should be taken not to drop projectiles, powder containers, or fuze or primer boxes. Projectiles should not be allowed to strike together. All safety precautions in handling ammunition given by Technical Manuals and regulations and other sections of this manual will be rigidly observed.

*h. Packings.*—Moisture-resistant seals of packed ammunition should not be broken until the ammunition is ready to be used. Rounds should not be withdrawn from containers until they are ready to be fired, unless the ammunition is to be loaded directly into the caisson. Fuze covers on powder time train fuzes and safety devices on fuzes will be removed just before firing and at no other time. Components of rounds prepared for firing but not fired will be returned to their original packings and appropriately marked and resealed. Such

components will be used first in subsequent firings, in order that stocks of opened packings may be kept at a minimum.

*i. Cleanliness.*—The complete round or each component should be inspected by a member of the gun crew for burs, dents, gravel, dirt, grease, etc., before loading into the gun. A cloth should be kept handy for wiping off grease, dirt, and foreign matter. Ammunition must be clean and free from dents before it is placed in the breech of the gun.

147. *General precautions during and after firing.*—*a. Defects and malfunctionings.*—AR 45-30 provides that all officers having charge of firing must make a report to the local ordnance officer of any ordnance matériel issued to the troops which malfunctions in firing or reveals defects either in firing or in storage, including such malfunctions and defects as are noted in target practice reports. It is the duty of the local ordnance officer to investigate all cases of malfunctioning and defects observed by him or reported to him and to report serious cases to the Chief of Ordnance through the corps area ordnance officer. Whenever an accident occurs which results in injury to personnel or damage to matériel, the lot of ammunition will be suspended from use and an immediate report will be made directly to the Chief of Ordnance by the ordnance officer under whose supervision the matériel is maintained or issued. One copy of this report will be sent to the corps area ordnance officer. Accidents of a serious or potentially serious nature require reporting by the quickest means of communication available. Until the arrival of an investigating officer, all evidence will be carefully preserved and, insofar as is practicable, will be left undisturbed.

*b. Protection to personnel.*—Whenever high explosive ammunition is fired, proper precautions will be taken to insure protection of all personnel against premature burst, as prescribed in AR 45-30. AR 750-10 gives the regulations and details for protection of persons in the vicinity of the firing point. Any individual in the military service who observes a condition which makes firing obviously unsafe will immediately give the command **CEASE FIRING**. If at a distance from the unit firing, he will make the prescribed signal therefor. No lethal or toxic gas will be used for training purposes in time of peace. When chemical ammunition other than smoke is fired, all persons will be provided with gas masks. The firing of shell and shrapnel over the heads of unprotected personnel in time of peace is prohibited.

*c. Firing through trees.*—When firing ammunition from a mask of trees, a premature burst may result if a fired shell or shrapnel strikes the branch of a tree. The striking of even a twig by a shell fitted with

a time fuze may result in a derangement of the setting or deformation of a time ring sufficient to cause a premature burst.

*d. Duds.*—A dud is a discharged but unexploded bomb, projectile, or grenade. It may result from defects in the fuze, booster, or charge; the unscrewing of fuzes in flight; or the character of the ground at the point of impact. Whenever a dud can be readily located and examined without moving it, an effort should be made to determine the cause of the failure. A dud in itself is a source of danger, and if improperly handled may result in an explosion with injuries to personnel. A comparatively slight blow or turning of the dud may cause it to explode at any time. Duds should be destroyed in place; for methods of destroying see chapter 4.

148. **Small-arms ammunition.**—*a.* Before issuing small-arms ammunition of any type, it will be examined. The procedure for examination and the defects to look for will be found in TM 9-1990. OFSB 3-5 contains essential information concerning the grading of small-arms ammunition and the disposition of fired components and unserviceable small-arms ammunition. Lots having more than 5 percent of defective cartridges will be subjected to 100 percent inspection, defective rounds culled out, the serviceable cartridges repacked prior to issue, and report made to the Chief of Ordnance. Normally, small-arms ammunition, unless it has been stored for a considerable period, will have no visual defects, and any ammunition having less than 5 percent visually defective rounds may be issued without 100 percent inspection. If 20 percent or more are defective, the lot is withdrawn from service and held for disposition. The post ordnance officer should see that the troops are instructed as to the kinds of visible defects which can be readily detected and the correct manner in which to cull ammunition. Particular attention should be paid to incipient cracks which are not easily detected unless the thumb is pressed against the bullet, thus exposing the crack in the cartridge case. Defective cartridges will be considered as grade 3 ammunition.

*b.* Since different types of small-arms ammunition are of similar appearance, this kind of ammunition will be strictly checked from the markings on the packing.

*c.* Blank cartridges should not be fired at a representative enemy at distances less than 20 yards, as the wad or paper cup may fail to break up.

*d.* (1) For procedure in the event of an apparent misfire see paragraph 56*a* and *b*.

(2) When a hangfire occurs in any lot, its use should be suspended and a report made to the post ordnance officer, giving the number of

the lot involved. The ammunition lot thus affected will be withdrawn and replaced by serviceable ammunition.

*e.* When a bullet lodges in the bore of a rifle, pistol, or machine gun, it should be removed by the application of pressure from the muzzle end of the weapon. *To attempt to shot the bullet out with another cartridge is dangerous and therefore prohibited.*

*f.* Dented cartridges, cartridges with loose bullets, or otherwise defective rounds should not be fired.

*g.* Misfires in which the primer explodes but fails to ignite the powder charge have proved dangerous in firing automatic arms with blank firing attachments. Some of the powder is blown into the bore and becomes lodged in the blank firing attachment. A series of such rounds will cause an accumulation of powder sufficient to cause serious damage when ignited by a normal cartridge. When misfires occur in excess of 5 percent in firing blank cartridges, the firing of that lot of ammunition will be suspended and reported to the Chief of Ordnance.

*h.* The use of armor-piercing cartridges is prohibited in demonstrations in which tanks take part. In using armor-piercing ammunition it is well to remember that the cores of bullets that fail to penetrate will rebound. The radius of rebound depends on several factors but may safely be taken at a maximum of 100 yards for caliber .30 and 200 yards for caliber .50, armor-piercing ammunition.

*i.* After a box of ammunition is opened and cartridges issued, each man should take care of his own ammunition. The primer should be protected from blows by sharp instruments, as such a blow might explode the cartridge.

*j.* The use of oil or grease on cartridges is prohibited. Such use causes the collection of injurious abrasives in automatic weapons and causes excessive and hazardous pressures on the bolt of the rifle when firing in nonautomatic rifles.

**149. Artillery ammunition.**—*a. Examination.*—Before firing, representative samples from each lot of ammunition should be examined for visible defects such as exudation, badly corroded fuzes, projectiles loose in cartridge cases, damaged rotating bands, excessive moisture and dampness, etc. If these defects are likely to cause difficulty when the fuze is set or the round is loaded into the gun, or there is any question as to the safety and functioning of the ammunition, it should not be used until it has been examined by the corps area ordnance officer or his assistants. Care should be used in condemning ammunition for use, as shell which are exuding slightly can be made serviceable as prescribed in Ordnance Field Service Bulletins, and many times fuzes which are only slightly corroded or discolored are serviceable and can be used.

*b. Packings.*—In removing fixed ammunition from boxes, the screws or wing nuts which hold the covers in place should be removed. If the ammunition is packed in individual tin or fiber containers, these containers should be opened by means of the tear strip provided, but the rounds should not be withdrawn from the container until it is to be fired, unless the ammunition is loaded directly into the caisson. Fuze covers on shrapnel should not be removed until the round is to be fired. All powder charges will be kept in their containers except the charge which is to be served to the piece for the next succeeding round.

*c. Placing of ammunition.*—Ammunition at the firing point which is not carried in caissons should not be located directly at the rear of the gun, but to the left of the caisson, and should be protected from moisture and dampness and the direct rays of the sun by a tarpaulin so placed that air can circulate through the pile.

*d. Propelling charges.*—(1) *Premature ignition.*—The powder charge for any given round will not be brought near the breech of the gun until the preceding round has been fired, the powder chamber carefully sponged with a wet sponge or cleared of any possible smoldering remains by use of the air projectors, and the face of the mushroom head wiped.

(2) *Flarebacks.*—When the breechblock is withdrawn, the gases remaining in the bore sometimes pass to the rear and ignite upon striking the air, regardless of the direction of the wind. Flames of varying length and intensity result. Precautions must be taken to prevent the flame from reaching a new propelling charge, as well as to prevent serious burns to the breech detail.

(3) *Blending.*—Propelling charges will be habitually fired as received. Blending will not be resorted to except in special cases where the necessity therefor has been approved by the Chief of Ordnance, who will furnish the necessary instructions.

(4) *Erratic and excessive pressures.*—Erratic pressures or ranges may be due to deteriorating propelling charges, improper ignition of the propelling charges, defective or loose rotating bands, and in the case of separate loading ammunition, to improper wrapping or lacing of the charge. Excessive pressures are likely to develop if the diameter of the propelling charge is altered so as to prevent the projection of the flame from the igniter to the front of the powder charge. For further information, see AR 750-10. All powder lots giving excess pressures should be immediately suspended from use pending instructions from the Chief of Ordnance. A sample of the powder involved should be sent to the nearest ordnance depot, together with a copy of the report of the malfunctioning and the record of the stability of the powder.

(5) *Maximum ranges.*—The caliber board report has purposely used

the term "supercharge" in referring to the propelling charge required to give maximum range. It cannot be too strongly emphasized that the normal charge should be used always within the ranges obtainable, and the use of supercharges must be avoided except where maximum ranges are necessary, otherwise excessive wear of the guns will result. With multisection propelling charges, when "supercharge" is desired the complete charge is used and when "normal charge" is desired the base section only is used.

(6) *Igniters.*—(a) In loading the separate loading propelling charge into the gun, care must be exercised that an igniter is always on the end of the charge toward the breech. The cloth used for making igniters is dyed red to indicate clearly the end which should be at the rear of the chamber. The red dye also indicates that the igniter contains black powder. Undyed igniter cloth has been used, however, for some propelling charges now in the service. In this case the igniter end can be identified by the quilting used to hold the black powder in position and the words IGNITING POWDER stenciled on the igniter.

(b) Propelling charges should not be placed in the gun with the igniter fastened thereto by safety pins. Before firing, the safety pins should be removed and the igniter pad attached to the charge by sewing, the stitching being caught in at least three places 120° apart.

(c) It is the practice to pack one igniter in each cartridge storage case. Surplus igniters remaining after firing should be destroyed in accordance with chapter 4.

(7) *Tags and protector caps.*—Igniter protector caps and data tags will be removed from the propelling charge before loading it into the gun.

*e. Difficulties in loading or extracting ammunition.*—Difficulties in loading or extracting ammunition may be due to dented or bulged cartridge cases or foreign material in the chamber or bore of the gun. Where the cartridge cases are hard to extract, an inspection of the chamber should be made to determine whether it is fouled, scored, or pitted. If it is fouled, it can be readily cleaned; but if it is pitted or scored, a report should be made to the post ordnance officer. If a projectile cannot be readily extracted from the gun or should a projectile become separated from the cartridge case when the breech is opened, it should be removed under the direct supervision of an officer, using a rammer which bears only on the projectile and provides for clearance around the fuze. Extreme care should be exercised to prevent any force from being applied against the fuze. The Edwards rammer, designated as rammer, unloading, M1, is provided for this purpose for use with 75-mm point-fuzed projectiles (fig. 66).

*f. Misfires.*—When a misfire occurs, the following precautions will be observed:

(1) *Fixed or semifixed ammunition.*—At least three attempts will be made to fire. After the last attempt, the breech will not be opened before 2 minutes have elapsed.

(2) *Separate loading ammunition.*—(a) If the primer is heard to fire, the breech will not be opened before 10 minutes have elapsed.

(b) If the primer is not heard to fire, two more attempts to fire will be made. Then—

1. If the primer can be removed by a person standing clear of the path of recoil, after 2 minutes have elapsed, the primer may be removed and a new one inserted. If the second primer fails, 10 minutes should be allowed to pass and then the breech may be opened.

2. If the primer cannot be removed safely as described above, no attempt will be made to open the breech or replace the primer for 10 minutes.

Misfire primers should be handled carefully and disposed of quickly due to the chance of a primer hangfire. Further information will be found in AR 750-10 and the Technical Manuals and Field Manuals pertaining to the piece.

*g. Fuzes.*—(1) Extreme care must be taken in handling and in assembling fuzes to shell or bombs. All fuzes must be treated as delicate mechanisms. The forces in the gun which arm the fuze can be simulated by rolling or dropping, and a fuze so armed may be functioned by the impact of a blow or by dropping.

(2) In the assembly of fuzes into projectiles, inspection should be made of the fuze body and threads and also of the adapter and fuze cavity to insure that grit, grease, or other foreign material is not present. This is necessary to insure proper seating of the fuze and to avoid the use of any great force. Cleaning of the fuze cavity should be accomplished with a piece of cloth and a small stick which can be inserted into the cavity. Fuze hole plugs should not be removed except for inspection or when the fuze is about to be inserted.

(3) When ammunition or projectiles are issued fuzed, no attempt should be made to remove the fuzes therefrom.

(4) Fuzes will not be altered. Any attempt to alter or disassemble fuzes in the field is dangerous and is prohibited except under specific direction of the Chief of Ordnance. The only authorized assembling or disassembling operation is that of fitting the fuze to the projectile if the round was not issued fuzed, or unscrewing the fuze from the projectile if not fired.

(5) Every precaution should be taken to keep moisture away from powder train time fuzes.

(6) Time fuzes are always issued set "safe" and if not used after making a setting they should be reset to "safe" before storing.

(7) Each round to be loaded which contains a point-detonating fuze should be kept well out of the path of recoil of the gun until recoil of the previous round has taken place, in order to prevent a heavy blow from hitting the fuze.

(8) When checking the accuracy of fuze setting by cutting trial fuzes, no fuze should be cut more than twice.

**150. Blank ammunition.**—*a.* Only blank ammunition furnished by the Ordnance Department will be used. Blank ammunition is issued to the using arms in complete rounds only. Smoke-puffs or blank ammunition will not be improvised where it is not provided for the piece.

*b.* The complete round of blank ammunition if kept intact, handled with care, and protected from fire provides a comparatively safe assembly. However, the following precautions should be observed:

(1) Under no circumstances will rounds of blank ammunition be tampered with in the field.

(2) Blank ammunition should not be removed from the fiber container sooner than is necessary before firing. Remaining rounds should be kept well away from the gun.

(3) Identification of the ammunition before firing must be positive and no attempt should be made to use it in a gun other than that for which it is intended.

(4) Any round in which the chipboard closing cup is not firmly in place should not be fired and should be handled with care until disposed of as directed in chapter 4.

**151. Pyrotechnics, grenades, and chemical ammunition.**—*a.* Pyrotechnics and grenades should be located some distance either to the right or left, and never directly behind the firing points. Protective measures against grass fires should be provided and extreme care should be taken to prevent a grenade or piece of burning pyrotechnic material from dropping into boxes of ammunition. Pyrotechnics which have been unsealed should be disposed of as provided in OFSB 3-9.

*b.* Smoke-producing materials will not be released in time of peace within 300 yards of personnel, livestock, buildings, equipment, or other objects which may be damaged. Equipment contaminated with corrosive acids produced by liquid smokes will be washed with water as soon as possible, except when other methods of protection or cleaning methods are prescribed in the appropriate Technical Manuals.



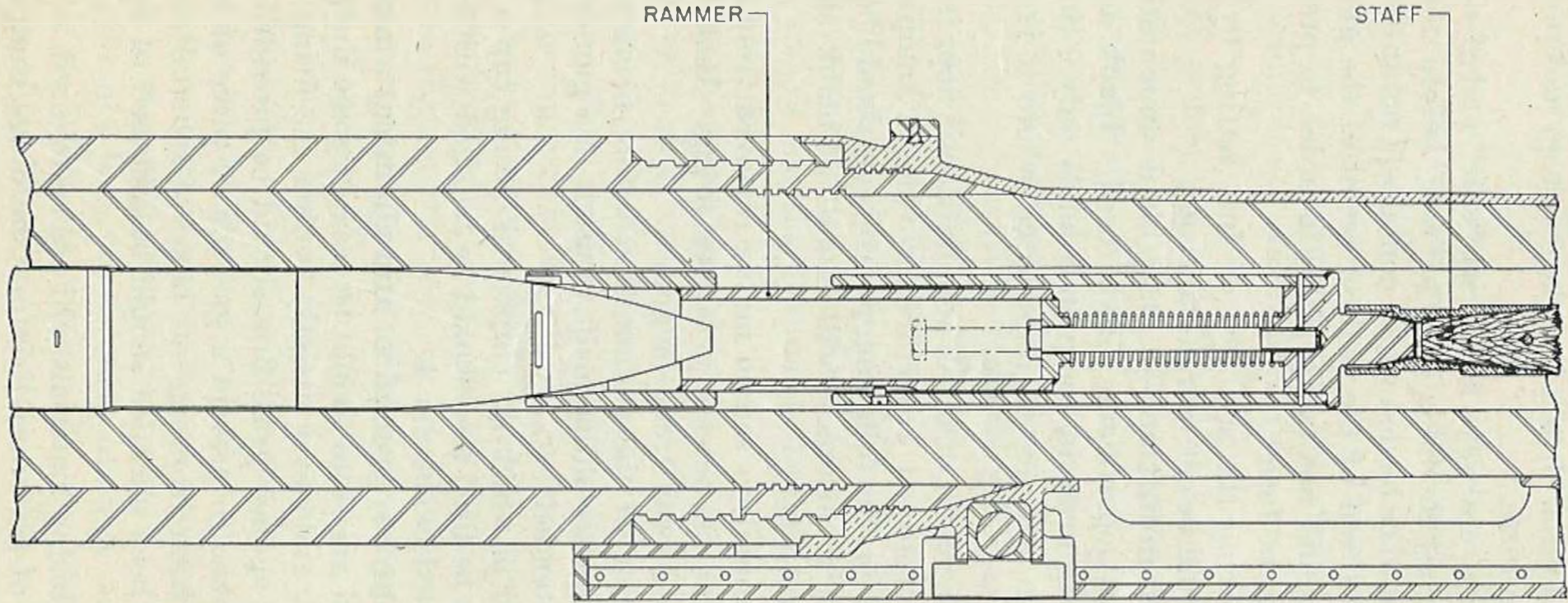

RA PD 4031

FIGURE 66.—Rammer M1 in use—method of removing shell from gun.

c. Burning type grenades, smoke pots, and two-compartment candles should be stored in a cool dry place. They should not be ignited within 5 feet of dry grass or other inflammable materials, if fire is to be avoided. Burning type grenades will not be fired closer than 20 feet from personnel, due to an occasional flashing grenade. In firing smoke pots, care should be taken not to have the face directly above the smoke pot when it is set on fire.

d. Unfuzed grenades will not be fuzed in ammunition dumps or storage magazines, nor in greater quantities than are needed for immediate use.

152. Bombs.—Procedure for precautions and repair of bombs in the field are given in OFSB 3-9. AR 750-10 prescribes precautions for the minimum altitude for functioning of bombs for aircraft in time of peace. Methods of unfuzing, disassembling, and handling bombs and safety precautions for the same are published in TM 9-1980. All live bombs will be carried safe and will not be armed until released.

153. Mortar ammunition.—The same safety precautions will be observed in the field in the handling and use of mortar ammunition as apply to artillery shell. Further information will be found in FM 23-85, FM 23-90, and TM 9-1935.

SECTION VII

AMMUNITION IN HARBOR DEFENSES

	Paragraph
General .....	154

154. General.—a. *Moisture*.—In harbor defenses, the principal problem is keeping the ammunition dry. Attention will be given to ventilation of magazines and stacking of ammunition in boxes with adequate skids and dunnage to insure free circulation of air through the pile.

b. *Blending*.—Propelling charges will ordinarily be fired as received. Blending of propelling powder will be done only on specific instructions from the Chief of Ordnance.

c. *Loading*.—Loading and renovation of shell will be done in accordance with instructions and specifications prepared by the Chief of Ordnance.

d. *Further information*.—Refer to other sections of this chapter.

SECTION VIII

AMMUNITION AT SUPPLY POINTS

	Paragraph
Supply points and distributing points.....	155
Storage of ammunition and explosives.....	156
Chemical ammunition.....	157

155. Supply points and distributing points.—*a. General.*—The details concerning ammunition supply points and distributing points, as discussed in this manual, are particularly applicable to those installations in the zone of the interior and at posts, camps, and stations. A complete discussion of the subject for application to the theater of operations (the communication zone and the combat zone) is contained in FM 9-6.

*b. Location.*—Supply points and distributing points should be located in the best available network of roads and near a railroad. Ammunition and explosives will be so located as to comply with the provisions of paragraph 116, with regard to quantity-distance requirements.

*c. Lay-out.*—In planning the lay-out of ammunition supply points and distributing points, consideration should be given to the following:

(1) *Amounts and kinds required.*—It is desirable that a field unit supply train be able to take on its complete load from stacks in a straight line or in a single area without having to enter and congest another area of the supply point.

(2) *Ease of access.*—They should be on good roads, near, but not on, main highways. Conspicuous signs should be posted on roads leading in, and military police should be notified of names and locations of dumps within their areas.

(3) *Traffic control.*—Roads should preferably be laid out in complete loops instead of turn-arounds. This has an additional advantage in that it provides access to piles from either of two directions. One-way traffic should be established.

(4) *Segregation by lots.*—As a general rule, ammunition should be piled so the lot numbers are easily inspected. Quantities issued to a single unit should be, if practicable, all of one lot.

*d. Fire protection.*—(1) The commanding officer will appoint a fire marshal who will be responsible for the rigid enforcement of fire-preventive measures. The fire marshal will prepare rules covering all local conditions and special fire risks. He will exercise strict fire discipline within depot or dump.

(2) Fire extinguishers, water barrels, sand boxes, and other fire-fighting equipment should be provided. A supply of ropes and hooks should be kept on hand to tear down piles of boxes should they catch fire. Spontaneous combustion due to presence of greasy rags or oily waste should be guarded against. The direct rays of the sun on ammunition, especially that containing smokeless powder, is likely to cause spontaneous combustion.

*e. Camouflage.*—Arrangements for camouflage and concealment

should be coordinated with the representatives of the Corps of Engineers. The use of natural cover, of existing roads, of existing inconspicuous structures, and irregularity in the shape and spacing of piles will assist in the concealment of the park. Further camouflage technique is described in the field manuals of the various arms, for example, FM 4-5, FM 5-20, and FM 6-130.

**156. Storage of ammunition and explosives.—a. Classes.—**When establishing dumps, the following classes of ammunition are considered:

- Boxed artillery ammunition.
- Separate loading shell.
- Propellent charges.
- Fuzes, primers, detonators.
- Mortar shell.
- Bombs, fragmentation.
- Bombs, demolition, general purpose, armor-piercing, depth; torpedoes and aerial mines (not containing explosive D).
- Bombs (containing explosive D).
- Mines, antitank.
- Grenades.
- Small-arms ammunition.
- Pyrotechnics.
- Chemical ammunition.

*b. Quantity and distance.*—These classes should not be stored together. Whenever practicable, the distance between piles and classes should be in accordance with paragraph 116.

*c. Precautions.*—(1) It is important to bear in mind the possibility of hostile fire from guns or aircraft scoring a direct hit on a pile of ammunition. This may mean the detonation en masse of that pile. Ammunition and components should be stored so that the neighboring piles will not be detonated by the explosion of one pile and so that not all of one type of component or complete round will be lost in any one explosion. There should be at least two piles of every type of ammunition or component stored. It is particularly important that fuzes, primers, detonators, etc., should be distributed as widely as storage facilities permit.

(2) Ammunition piled in the open should be raised off the ground at least 6 inches and protected from rain and direct sun by paulins. If drainage is not good, ditches should be dug around piles. All piles, indoor and outdoor, should be made with liberal use of dunnage and away from contact with walls, barricades, etc., to insure free circulation of air.

(3) During the time ammunition is in dumps, advantage should be

taken of every opportunity to place each round in good condition for firing. Lost fuze hole plugs should be replaced, burs in threads and rotating bands removed, and any other defect that might affect the serviceability of ammunition should be corrected. However, the work should be done at a safe distance from the piles.

**157. Chemical ammunition.**—Chemical ammunition should always be stored away from other munitions, and gas shell should always be stored on their bases. The following additional precautions should be taken in storing and handling this type:

*a.* Shell should be stored so that a leaky container can be removed immediately upon detection.

*b.* Every man working near gas shell should be equipped with a gas mask.

*c.* Tubes of oxygen and first-aid equipment should be placed in conspicuous places in charge of a chemical noncommissioned officer.

*d.* Should an accident occur and a worker be overcome, first-aid remedy will be applied and a doctor called.

*e.* Any type of ammunition exposed to gas must be cleaned with an oily cloth at once.

*f.* Conspicuous wind vanes should be set up in places where gas shell are handled.

*g.* Munitions containing phosphorus should always be stored alone and water-filled tubs kept available. Phosphorus ignites spontaneously when exposed to air, and submerging in water will extinguish the fire only as long as the material is kept submerged. Leaky phosphorus shell must be kept under water until they can be destroyed.

*h.* Pyrotechnics, incendiaries, and HC, CN-DM, and CN grenades should be kept dry.

*i.* Full use of dunnage should be made in storing chemical ammunition.

## CHAPTER 4

# DESTRUCTION OF UNSERVICEABLE AMMUNITION

	Paragraph
General .....	158
Safety precautions .....	159
Bulk explosives .....	160
Separate loading propelling charges .....	161
Artillery shell .....	162
Blank ammunition for cannon .....	163
Bombs .....	164
Mortar shell .....	165
Small-arms ammunition .....	166
Small components except primers .....	167
Primers .....	168
Grenades .....	169
Pyrotechnics .....	170
Chemical ammunition .....	171
Antitank mines .....	172
On target ranges .....	173

158. **General.**—*a. Scope.*—At posts, camps, and stations, the only ammunition items requiring destruction are obsolete or deteriorated ammunition, which may be considered together, and duds. The instructions set forth in this chapter are for destroying limited quantities of explosives and ammunition. When larger quantities are to be destroyed or the instructions set forth cannot be complied with, special instructions will be furnished by the Chief of Ordnance. The term “limited” is defined in *d* below.

*b. Responsibility and procedure.*—(1) Prior to destruction, an Ammunition Condition Report (O. O. Form 7235) will be submitted to the Chief of Ordnance in order that the disposition may be approved. This report will show what parts, if any, are to be salvaged. An exception is the case of deteriorated explosives or ammunition which are found to be immediately dangerous to life or property; disposition may be made by order of the local commanding officer. Usually the post ordnance officer is also the inspector for all ordnance property; hence the responsibility both for disposition and actual destruction rests upon him. Where local breakdown of unserviceable ammunition is ordered, technical instructions for the work will be furnished by the Chief of Ordnance.

(2) Unexploded ammunition and explosives in the theater of operations in time of war often must be destroyed, giving consideration to

tactics and time available. FM 5-25 describes methods for destroying duds and other dangerous ammunition found in the field in time of war, which work is to be done under the supervision of an engineer or ordnance officer.

*c. Methods.*—Destruction of explosive material will be accomplished by burning, exploding, or dumping at sea, as specified below. Burying of explosives or ammunition or dumping them into waste places, pits, wells, marshes, shallow streams, or inland waterways is absolutely prohibited, except for black powder as specified below. Methods for destruction are generally based on the number of units to be destroyed, size and nature of each unit, facilities available, and topography of the land.

*d. Quantity of ammunition and explosives.*—By a limited quantity of ammunition and explosives, this chapter refers to the number of unexploded shell and other ammunition to be normally found on a target range or in the field as an accumulation from firings or other peacetime maneuvers. Larger quantities, generally referring to ammunition resulting from deterioration in storage or obsolescence, are destroyed according to specific instructions from the Chief of Ordnance.

*e. Materials used in destroying by explosion.*—Charges of 1/2-pound blocks of TNT or sticks of dynamite are used. These are set off either by safety fuze and a blasting cap or by a magneto and an electric blasting cap. Nitrostarch blocks have been authorized for issue in place of TNT blocks for demolition purposes. Nitrostarch is a hard, dense substance, somewhat more sensitive to friction and impact than TNT. The crushing or breaking of the nitrostarch blocks is hazardous.

*f. Materials used in destroying by fire.*—Fires used in destroying small ammunition components may be made from scrap lumber, wood, or such material as excelsior. When components to be destroyed are laid on the pile before lighting, the fire will be lit from a distance by means of a train of inflammable material or by a charge of black powder ignited with an electric squib.

*g. Dumping at sea.*—Military Establishments located near a deep sea waterway may use this method of disposal. It is particularly advantageous for shell, bombs, and loaded components which are ordinarily destroyed by explosion. In addition to the precautions in sections I and V, chapter 3, the following will be observed:

(1) Port authorities will be consulted and their regulations regarding transfer and disposal will be complied with.

(2) All material to be disposed of will be removed from its containers and packings before being dumped overboard. Instances are

on record of ammunition, thrown overboard in heavy containers, being washed up from great distances and depths.

(3) Unless a definite location for dumping is assigned by port authorities, no explosive material will be thrown overboard within 10 miles of shore.

(4) In transit the boat or barge will display a large red flag at least 10 feet above the deck and a competent man will be constantly on the alert to warn approaching craft of danger.

*h. Specific type.*—Information dealing with the particular type to be destroyed will be found in the paragraphs following.

**159. Safety precautions.**—*a.* Safety is the major consideration in destroying ammunition and explosives. It is highly advisable to test all safety devices beforehand by subjecting them to the severest test they may be called upon to withstand, provided that such test is reasonable and practicable. Only after the requirements of safety have been satisfied should salvage and economy be considered. To accomplish his purpose, the officer will often have to improvise apparatus from all available sources. It is necessary that the ordnance officer analyze and plan the destruction procedure in detail and then compare it with the general safety precautions in chapter 3 and those given below. The general safety precautions that must always be complied with in destroying ammunition are described below.

*b.* Explosives and ammunition will not be destroyed by detonation if magazines or other buildings are in danger of being damaged by fragments or shock. If the distance from the place of destruction is less than 800 yards, a pit or trench which will limit effectively the range of the fragments will be used.

*c.* All dry grass, leaves, and other inflammable materials within a radius of 200 feet from the point of destruction will be removed. Fire-fighting facilities for combating grass fires should be maintained readily available, and if practicable, the ground at the point of destruction should be wet down with water at the close of each day's operations.

*d.* Personnel engaged in demolition work will always take cover. Fuzes should be tested beforehand for time of burning so as to give personnel ample time to reach shelter affording substantial overhead cover and splinterproof protection. Safety fuze too large in diameter to enter the blasting cap without forcing will not be used. If an electric blasting machine is used, the wires will not be connected to the terminals until all persons have reached cover. Depending upon local conditions, temporary or permanent barricades will be provided and safety distances will be observed by all persons.

*e.* Pits, trenches, and bombproofs will always be provided with sub-



stantial cover, such as a layer of logs and 2 feet of earth, to limit the range of fragments. When pits are used, they should be free from stones or other objects which might form missiles.

*f.* Pits will not be required when the destruction takes place on an artillery range or similar site. A cover of earth 2 feet thick should be used to limit the range of fragments.

*g.* Explosives or ammunition to be destroyed by burning will be removed from containers, as an attempt to burn explosives or ammunition under even slight confinement may result in an explosion or detonation.

*h.* The quantity of matériel to be destroyed at one time will depend upon local conditions. This quantity will be carefully determined by starting with a limited number and then gradually increasing that number until the maximum which can be destroyed without damage to surrounding property or causing disturbance to civilian areas is determined. The responsible officer will make sure before he gives the signal for detonation that there is no unauthorized person in the danger area and that all authorized persons are protected by adequate cover.

*i.* As some types of ammunition are comparatively difficult to explode, a search of the surrounding grounds should be made after each blast and any matériel which has been thrown from the pit and not detonated should be collected and included with the next charge to be destroyed.

*j.* Explosives or ammunition awaiting destruction will not be piled within 200 feet of the point of destruction and will be protected from grass fires, burning embers, and flying fragments. All dry grass, leaves, and other inflammable material will be removed from the area within a radius of 50 feet of the pile.

*k.* In repeating burning operations, care will be taken to guard against matériel being ignited from burning residue or heat in the ground.

*l.* The use of improvised methods for exploding blasting caps is prohibited.

*m.* In case of a misfire, personnel will not approach the pit, trench, or point of detonation until a period of 30 minutes has elapsed.

*n.* Destruction of ammunition will never be attempted by inexperienced or untrained personnel. The number of personnel engaged in such operations will be kept at a minimum consistent with safety. No person will be permitted to work alone.

*o.* Guards, safety signals, and warning signs will be used as required to keep unauthorized personnel from danger areas during destruction operations.

p. In the absence of specific regulations or information covering any phase of the destruction of explosive matériel, instructions will be requested from the Chief of Ordnance.

**160. Bulk explosives.**—*a. Black powder.*—The safest method of destroying black powder is to dump it in a stream or body of water; but if no suitable body of water is convenient, it may be burned. In opening the containers only tools of wood or nonsparking metal will be used. The contents of one container only will be burned at one time. The powder must be removed from the container and spread out on the ground in a train about 2 inches wide, care being taken that no part of the train parallels another part except at a distance of more than 10 feet. A train of inflammable material, such as excelsior, about 5 feet long and extending to windward, must be used to ignite the powder, as the resulting flare of explosion is so quick that there will be no opportunity to withdraw. The emptied containers will be thoroughly washed on the inside with water, as serious explosions have occurred with supposedly empty black powder cans. Safety precautions, particularly paragraph 159, should be observed.

*b. TNT, explosive D, and tetryl.*—These high explosives will be destroyed by burning. They must not be dumped into water, as they poison it. The explosive to be burned will be removed from containers and spread in a thin layer, not more than 3 or 4 inches thick, on another layer of inflammable material, such as excelsior. A train of inflammable material will be used to ignite the explosive. Not more than 500 pounds will be burned at one time. Safety precautions in paragraph 159 should be observed.

*c. Smokeless powder.*—Small quantities of smokeless powder (a few boxes) up to 500 pounds may be destroyed with safety if the powder is removed from the containers and spread out on bare ground in a train of limited width and thickness dependent upon the granulation of the powder. A train of inflammable material about 25 feet long, and on the windward side, should be used to ignite the powder and allow personnel sufficient time to get away from the intense heat which is generated when smokeless powder burns. Safety precautions in paragraph 159 should be observed.

*d. Other explosives.*—If it is necessary to destroy other explosives, such as mercury fulminate, lead azide, picric acid, dynamite, etc., special instructions will be requested from the Chief of Ordnance.

**161. Separate loading propelling charges.**—Extreme precautions will be taken against sparks. Smokeless powder will be removed to the burning ground before being opened. There the powder will be removed from the bag by cutting one of the seams, care being taken not to disturb the black powder igniting charge. The empty bag and

igniter should be immediately and completely submerged in water and the igniter cut open under water. The smokeless powder will be burned as prescribed in paragraph 160*c*. The igniter and cartridge bags, after having been thoroughly soaked in water for at least 72 hours, should be removed and allowed to dry in the open, and then they may be burned in a pit or trench. The soaking in water is absolutely necessary, because even the confinement of the black powder by the powder bag, slight as it may be, is sufficient to cause an explosion and the projection of the burning bags and igniters to distances of 200 feet or more. Bags and igniters awaiting destruction by fire must be kept in a securely closed container. It is permissible, when practicable, to destroy bags and igniters by dumping them in a body of water after the various sections of the quilted igniter are cut open while the bag and igniter are still submerged in water. This cutting is necessary to release air trapped in the quilted igniter sections which would cause the bags and igniters to float on top of the water.

162. **Artillery shell.**—*a*. The following general instructions for destroying artillery shell by detonation apply equally well to bombs, mortar shell, and other relatively large components containing high explosive. However, it must be kept in mind that bombs, mortar shell, and antitank mines are composed of as much as 60 percent explosive by weight and have relatively thin walls, as compared with the 10 to 15 percent of explosive in and the relatively heavy walls of artillery shell. Therefore, the number of units of bombs, mortar shell, and mines destroyed in one operation should be reduced accordingly. Fixed shell will be disassembled from complete rounds and destroyed in the same manner as separate loading shell (see below). Before undertaking any demolition operation, the proposed procedure will be checked against the safety precautions prescribed in paragraph 159.

*b*. The following general instructions contemplate the use of a pit or bombproof hut. An artillery range or similar site when available may be used. Note specially paragraph 159*e* and *f*.

*c*. The projectile to be destroyed will be placed on its side in a trench or pit about 4 feet deep. TNT blocks, or the equivalent, to the number specified in the following table will be placed in intimate contact with the side of the projectile and held in position by earth packed around the projectile. The TNT block is placed on its side; and, if two blocks are used, one is placed on top of the other. If three blocks are used, two are placed close together on the shell and the third on top of these. If five blocks are used, there will be two layers of two blocks each with a fifth on top. The demolition blocks are detonated by means of an electric blasting cap or miner's safety fuze and cap.

Caliber of shell to be destroyed	Number of ½-pound TNT blocks or its equiva- lent needed
37-mm, 2.24-inch.....	1
2.95-inch, 75-mm, 3-inch.....	2
4.7-inch, 155-mm, 6-inch.....	3
8-inch, 9.2-inch, 240-mm.....	4
10-inch, 12-inch.....	5
14-inch, 16-inch.....	6

*d.* One end of the required length of miner's safety fuze (see par. 159*d*) will be cut across with a sharp knife and inserted in a No. 8 blasting cap until it just touches the charge. The cap will then be lightly crimped to the fuze with a fuze crimper or suitable tool, care being taken not to press the fuze too tightly against the fulminate charge of the blasting cap. A No. 8 electric blasting cap with the necessary length of lead wire and a hand exploder may be used instead of the blasting cap with miner's safety fuze. The blasting cap will be placed in the hole drilled in the TNT block (the top block when more than one block is used) and if necessary a small amount of mud will be packed around it to hold it securely in place. In no case should a cap weaker than the ordinary commercial No. 8 blasting cap be used.

*e.* In case of a misfire, the precaution in paragraph 159*m* should be observed. After the blast, paragraph 159*i* should be complied with.

*f.* Point-fuzed shell, fitted with adapters and boosters, can be detonated without the use of TNT blocks, as a No. 8 blasting cap securely held in place in the fuze cavity with a small amount of mud packed around the top of the cap will usually insure complete detonation of loaded shell.

**163. Blank ammunition for cannon.**—Rounds of blank ammunition which have misfired will be destroyed locally under the supervision of a commissioned officer or personnel designated for this purpose by the corps area ordnance officer. The precautions for handling black powder, chapter 3, and for destroying ammunition, paragraphs 159 and 160, should be observed. An extractor (brass) having a wood screw thread can be used to remove the closing cap and wad; the black powder may be removed by washing or flushing out with water; and the primer removed by means of a press.

**164. Bombs.**—Bombs should be destroyed in accordance with paragraph 162. However, bombs have such thin walls and contain

so much more explosive than shell of corresponding weight, and usually detonate so completely that extreme precautions must be taken to avoid structural damage to buildings and injuries to personnel. The destruction of bombs larger than the 100 pounds should not be undertaken without the specific approval of the Chief of Ordnance. Bombs awaiting destruction should be segregated in small piles 100 feet or more apart, and at least 300 feet from the detonating pit. Extreme precautions must be taken to protect bombs awaiting destruction against accidental detonation by fire, fragments, or sympathetic detonation.

**165. Mortar shell.**—Mortar shell should be destroyed in accordance with the instructions in paragraph 162. Care will be taken to limit the number destroyed at any one time and to protect shell awaiting destruction from flying fragments.

**166. Small-arms ammunition.**—*a.* All unserviceable caliber .22 and shotgun ammunition will be destroyed locally. Ordnance field representatives, within their jurisdiction, are charged with the disposition of all other unserviceable small-arms ammunition and accumulations from firings. Reference to OFSB 3-5 should be made for procedure to be followed in disposition.

*b.* Small-arms ammunition should be destroyed in a pit which is approximately 6 feet square and 4 feet deep. An inclined chute such as a piece of 2-inch pipe should be provided, and this chute should be placed so that one end is over the center of the pit and the other behind the barricade. Precautions should be taken to baffle the open end behind the barricade so that the operator cannot look down the pipe. A hot fire should be built in the pit and then the pit should be covered with a piece of sheet iron or other suitable material to confine flying fragments. The cartridges should be fed into the fire through the pipe and care should be taken to prevent an accumulation of unexploded ammunition in the pit.

**167. Small components except primers.**—*a.* These components, artillery and grenade fuzes, boosters, detonators, and similar matériel, may be destroyed either by burning or by exploding. For destruction of primers see paragraph 168.

*b.* In destruction by burning, the same instructions given in paragraph 166*b* for the destruction of small-arms ammunition should be followed. Caution should be exercised in introducing components into the fire because normal action cannot be expected under intense heat. The explosion of a previously introduced component should be heard before introducing another.

*c.* In accomplishing the destruction of these components by explosion, a small number of components, depending upon the type and

kind, should be placed in an open container and in intimate contact with one another. This container should then be placed in a pit or trench approximately 4 feet deep. On top of each container, in intimate contact with the components, should be placed one or more TNT blocks fitted with an electric blasting cap or with a common blasting cap and safety fuze. The pit should then be covered with a layer of logs and earth or other suitable cover, and then the components should be detonated in accordance with the safety precautions outlined in paragraphs 159 and 162.

168. **Primers.**—*a.* Large primers, 100-grain or larger, may be destroyed by burning according to the instructions for destruction of small-arms ammunition in paragraph 166*b*. Primers, other than small-arms primers, are dropped one at a time into the fire. Large primers will be destroyed only in this manner, as they are subject to explosion en masse if destroyed by burning in large quantities.

*b.* Primers, except the 100-grain or larger primers, may be burned in a trench approximately 2 feet deep, 1 foot wide, and of sufficient length to accommodate the number of primers to be burned at one time. The trench should be prepared with a quantity of excelsior or similar combustible material sufficient to insure a hot fire throughout its length. The primers should be removed from boxes and placed on the excelsior before the fire is lighted. Pasteboard cartons need not be opened before they are placed in the trench. A piece of sheet metal should be placed over the trench, to confine fragments as much as possible. Sufficient space should be left to allow a draft through the trench. After the primers and cover are in place, a train of combustible material leading into the pit should be prepared and lighted. Personnel should then take cover or withdraw to a safe distance.

*c.* If a suitable tank or kettle is available for use, a small number of primers may be placed in it and a small-mesh screen placed over the top. By building a fire underneath, the primers will be exploded. A convenient receptacle is an iron tank, cut in half longitudinally and the open side placed down on railroad iron or other suitable grating that will not let the primers drop into the fire. A large hole, approximately 12 inches in diameter, with a pipe located above the height of a man's head, should be provided and about 50 primers put in at one time. The boiler should be equipped with a smokestack so that a draft will be formed through the grating. Packing material, if inflammable, need not be removed from the primers.

*d.* If a burning pit constructed of railroad iron or similar material is available a fire may be built in it and a box of primers destroyed at

one time, provided the packing is inflammable, by throwing the box into the pit and taking cover.

*e.* The 20-grain and 49-grain primers may be destroyed by building a firebox over which a basket of primers may be pulled on railroad iron from behind a barricade. The fire should be started before the primers are pulled over it. When all primers have been fired, the basket should be pulled off, emptied, cooled, reloaded, and again pulled over the fire.

*f.* The stock of primers awaiting destruction will not be allowed within 300 feet of the burning operations, and great care will be taken to protect the pile from accidental ignition by flying fragments or sparks. This stock will be limited to a day's supply. Other applicable regulations, contained in paragraph 159, will be strictly observed.

**169. Grenades.**—*a. General.*—Grenades may be destroyed by burning or exploding in accordance with the following instructions. A strict compliance with applicable regulations of paragraph 159 is essential for the protection of personnel and property. Destruction by explosion should, in general, be applied to high explosive grenades, whereas destruction by burning is applied generally to other types of grenades.

*b. Destruction by explosion.*—Not more than 20 grenades should be placed in a pit about 4 feet deep. They should be piled so that they come in close contact, and on top of the pile there should be placed, in intimate contact, three ½-pound TNT blocks, one of which is provided with a No. 8 electric blasting cap or No. 8 blasting cap fitted with several feet of safety fuze. The grenades and TNT blocks should be covered with a layer of earth about 1 foot thick and tamped lightly to obtain the maximum efficiency of the TNT blocks, and the pit should be covered as prescribed in paragraph 159*f*.

*c. Destruction by burning.*—A pit 2 feet square by 3 feet deep fitted loosely with an iron plate or heavy board cover is used. Grenades should be put in the fire one at a time. Another should not be put in until the previous grenade is exploded. Care should be taken in introducing explosives into the fire as normal action cannot be expected under intense heat. The time to investigate an unusual delay in the explosion of a grenade is only after the fire has burned out and the pit is cold. An inclined chute baffled at the open end may be used, instead of dropping them singly and covering each time.

**170. Pyrotechnics.**—*a. General.*—Pyrotechnics, except photoflash bombs and parachute flares, will be destroyed in accordance with the instructions for burning primers, paragraph 168*b*.

*b. Parachute flares.*—Parachute flares will be destroyed by burning

in a vertical position on the ground and in the open. The individual flares must be located at least 4 feet apart and placed on top of a layer of combustible material. After lighting the train of combustible material, personnel should take cover and observe safety distances.

*c. Photoflash bombs.*—Photoflash bombs are dangerous and should be handled with care. They should be destroyed by the use of TNT blocks and destroyed similarly to the procedure for artillery shell, paragraph 162. Duds of photoflash bombs should not be handled but destroyed in place in accordance with instructions set forth in paragraph 173. Due to the thinness of the case, a single block of TNT is sufficient to accomplish destruction. A strict compliance with the applicable regulations of paragraph 159 is essential.

**NOTE.**—Due to the brilliancy of the flash, it is detrimental to vision to watch the destruction of photoflash bombs even at distances prescribed in this manual as safe against fragments.

**171. Chemical ammunition.**—*a.* In general, grenades and shell loaded with chemical filler should be destroyed in a manner similar to that prescribed in paragraph 162 for destroying artillery shell. However, before destroying chemical ammunition special instructions should be obtained from the Chief of Ordnance concerning any exceptional hazards. When a leaking shell or component is located, the officer in charge of the magazine will be notified in order that he may direct the disposition of the shell. As chemical shell contains a comparatively small amount of explosives, the charge of TNT blocks to be used for demolition should be as follows:

Chemical shell or component	Number of ½-pound TNT blocks or equivalent
75-mm shell.....	4
155-mm shell.....	5
8-inch shell.....	6
3-inch, 4-inch, and 81-mm chemical mortar shell.....	2
4.2-inch chemical mortar shell.....	3
8-inch chemical mortar shell.....	3
Bomb, 5-pound.....	1
Bomb, 25-, 30-, and 50-pound.....	2
Bomb, 100-pound.....	3

*b.* Immediately hazardous unserviceable chemical ammunition may be destroyed by exploding in the open if a sufficiently isolated area is available. The point where the shell is exploded should be chosen so that personnel can be excluded for a period of approximately 48 hours from the area 1 mile downwind from the point where the shell



is exploded. All personnel must be prevented from passing within a distance of 150 yards from the point where the shell is exploded for a period of about 2 weeks. Where a sufficiently isolated area is not available, single unserviceable gas-filled shell may be destroyed in a pit 6 feet deep. The shell with its bursting charge is placed at the bottom of the pit, the pit is back-filled, and the shell exploded. Five gallons of freshly prepared bleaching solution should be poured on the fill and then sufficient dry bleach should be scattered over the fill to cover the disturbed ground to a depth of 2 inches. A permanent sign should be placed on the fill, prohibiting digging in the vicinity.

**172. Antitank mines.**—If marks on the mine or on the ground indicate that it has been run over by a vehicle, the mine should be considered as a dud and destroyed in place by detonation with a TNT or nitrostarch block, without handling or jarring the mine. Only mines that have not been tampered with, handled, or disturbed in any manner may have the safety fork replaced and then taken up. The safety fork must be replaced before any handling of the antitank mine or before removing the fuze. Unserviceable antitank mines will be destroyed in the same manner and with the same precautions as bombs.

**173. On target ranges.**—*a. General.*—Explosive missiles which have failed to function after firing are termed “duds.” AR 750-10 prescribes that, after firing on a range has been completed and before free access to it is allowed to personnel in general, the range will be thoroughly policed and all duds destroyed by competent personnel. Duds of photoflash bombs or aircraft flares released during flight over land areas other than target ranges will be recovered and destroyed.

*b. Safety precautions.*—Target ranges are made dangerous by flying missiles during target practice and by unexploded ammunition which may remain on the range after target practice. Safety precautions should therefore include means for preventing trespass upon the target range by unauthorized or careless persons and for removing from the range all unexploded ammunition which has been fired. In addition to the safety measures employed at and near the firing line, such as red flags, markers, or fences, the boundary or terrain which is likely to receive missiles from the firing line should be placarded with signs which indicate the danger zone and the hazards attendant upon entering such zones at specified times. The signs should also emphasize the dangers connected with picking up unexploded ammunition and should prohibit either trespass on the range or the removal of souvenirs from areas, under penalties provided by law. The placarding of the target ranges is a matter of public safety and will never be neglected.

*c. Destroying duds.*—(1) The policing of a target range and insuring the safety of the command are functions of the commanding officer. Immediately after target practice is completed, the entire range should be carefully policed for unexploded ammunition, under the supervision of an authorized officer who is thoroughly familiar with the dangers incident to such operations. Unexploded projectiles and other components of ammunition which have been fired are dangerous to handle and should not be touched or jarred where it is practicable to destroy the same by the use of dynamite or TNT blocks. However, unfuzed duds may be handled with comparative safety.

(2) In those rare cases in which it is necessary to remove a dud from any location before destroying it, all operations connected with this procedure should be done either by or under the direct supervision of personnel who are thoroughly familiar with the dangers of such an operation and who have qualified to do this work.

(3) To place an unexploded fired projectile on its base or nose is to invite disaster, as such an operation will cause movement of the internal fuze parts and may cause the projectile to explode. No attempt should be made to disassemble a round of unexploded ammunition except by experts of the Ordnance Department who are specifically assigned to such work.

(4) Duds on the target range, such as unexploded projectiles, fuzes, grenades, etc., can usually be destroyed in place with TNT blocks or sticks of dynamite placed in intimate contact with the dud and in all cases covered with sandbags or earth to limit the range of the fragments. Shell exploded on the ground surface without tamping may send fragments 1,000 yards, and all within this danger zone will take cover when the charge is fired. Personnel should never be within 100 yards of a projectile when it explodes, even if suitable protection is at hand. The general instructions for destroying duds on the target range are similar so far as possible to those described for destroying artillery ammunition, paragraph 162. Duds of photoflash bombs are destroyed in accordance with this paragraph and paragraph 170. The safety precautions in paragraph 159 should be carefully observed.

(5) Gas shells or bombs should be handled in the same manner as other projectiles. Holes or trenches in which gas shells have been exploded must be filled or decontaminated and gas masks worn during the work. Work should always be done on the windward side of the area where gas shells are exploded.

(6) As an added precaution, after the destruction of duds has been completed the officer in charge of the work will personally superintend a thorough search of the area in order to insure that no duds have been overlooked.

## GLOSSARY

- Adapter*.—Threaded bushing used to adapt a fuze to a projectile or bomb.
- Adapter-booster*.—Adapter and booster assembled as a unit for a bomb or shell.
- Aircraft bomb*.—See Bomb.
- Aircraft signal*.—Signal for use from aircraft.
- Aliquot part charge*.—Separate loading propelling charge divided into equal sections; also referred to as equal section charge.
- Allways fuze*.—Fuze used with mortar shell which will function regardless of the part of the shell striking the target.
- Amatol*.—A high explosive, a mixture of ammonium nitrate and TNT.
- Ammonal*.—A high explosive containing TNT and powdered aluminum.
- Ammunition*.—Munitions and components, containing an explosive element, expended in combat.
- Ammunition data card*.—A 5- by 8-inch card giving pertinent information necessary for complete identification and for handling, storage, and use.
- Ammunition lot*.—A batch of rounds or components, each of which is manufactured by one manufacturer under uniform conditions, and which is expected to function in a uniform manner.
- Ammunition lot number*.—Number which identifies an ammunition lot.
- Antitank mine*.—Fuzed ammunition, buried or concealed, which functions when a tank passes over it.
- Arming*.—To put a fuze in a condition whereby it can function.
- Arming pin*.—A pin in aircraft bomb fuzes which serves to arm the fuze upon being withdrawn.
- Arming vane*.—A miniature propeller which acts to arm aircraft bomb fuzes, after the bomb has fallen some distance below the airplane.
- Arming wire*.—A length of wire which, while attached, prevents a fuze from arming.
- Armor-piercing*.—Bullets and projectiles having a hardened steel element designed to pierce armor plate.
- Artillery ammunition*.—Ammunition fired from cannon.

*Auxiliary booster.*—An additional booster required for a large bursting charge which ordinarily would not be properly detonated by a booster alone.

*Ball cartridge.*—General purpose small-arms ammunition for standard service.

*Ballistic coefficient.*—The numerical measure of the ability of a projectile to overcome air resistance and maintain its velocity.

*Ballistics.*—That branch of applied mechanics which treats of the motion of projectiles, internal ballistics dealing with the motion within the gun and exterior ballistics dealing with the motion after leaving the gun.

*Ballistite.*—A double-base type of propellant powder used in some small-arms and mortar ammunition.

*Bandoleer.*—A pocketed belt used as a means of carrying small-arms ammunition so as to be readily accessible.

*Barrel.*—The tube of a gun.

*Base and increment charge.*—A semifixed or separate loading propelling charge consisting of a base section and one or more increment sections usually of less weight than the base section.

*Base charge.*—(1) A black powder charge in the base of shrapnel.  
(2) A propellant charge for inner zone howitzer firing.

*Base cover.*—A metal disk secured to the base of high explosive shell to prevent hot gases from coming in contact with the bursting charge through possible flaws in the base of the shell.

*Base-detonating fuze.*—A fuze located in the base of a projectile.

*Black powder.*—A low explosive consisting of an intimate mixture of sulfur, charcoal, and saltpeter.

*Blank ammunition.*—Ammunition without projectile used in saluting, signaling, or simulating fire.

*Blasting cap.*—A thin copper shell containing a sensitive explosive and fired by a slow-burning safety fuze or an electric current.

*Blinker.*—An aircraft pyrotechnic signal burning with intervals of light separated by a period of darkness.

*Boat-tail.*—A tapered base of a projectile.

*Body.*—The portion of a projectile immediately to the rear of the bourrelet.

*Bomb.*—A container of explosives or chemicals or both with fuze, dropped by aircraft.

*Booster.*—A high explosive component which amplifies the explosion of the fuze to detonate properly the bursting charge of a shell or bomb.

*Bore.*—The opening through the length of the barrel of a gun.

*Bore safe.*—A bore-safe (detonator-safe) fuze is one in which the explosive train is so interrupted that prior to firing, and while the projectile is still in the bore of the cannon, premature action of the bursting charge is prevented should any of the more sensitive elements, primer and/or detonator, malfunction.

*Bouchon assembly.*—Name formerly applied to grenade fuzes.

*Bourrelet.*—The machined raised portion of a projectile which bears on the bore.

*Breech.*—The end opposite the muzzle of a gun.

*Breech mechanism.*—A mechanical device for closing the rear end of the chamber or bore of a gun after loading, and for firing the inserted round of ammunition.

*Brisance.*—The shattering ability of high explosives.

*Bullet.*—Projectile of small-arms ammunition.

*Bull's-eye powder.*—A double-base type of propellant powder used in small-arms ammunition.

*Burster.*—An explosive element used in chemical shell to open the shell and disperse the contents.

*Bursting charge.*—The explosive filler of ammunition.

*Caliber.*—(1) The diameter of bullet or projectile, expressed in inches or millimeters. (2) The measure of length of a cannon.

*Canister.*—An artillery projectile, containing only small balls, which disrupts upon leaving the muzzle of the weapon, producing a shot-gun shell effect.

*Cannelure.*—A groove.

*Cannon.*—A gun, howitzer, or mortar, on a mount or carriage.

*Cartridge.*—A complete round of small-arms ammunition.

*Cartridge bag.*—Cloth bag used to hold the propelling charge for semifixed and separate loading ammunition.

*Cartridge case.*—A brass case containing the propellant powder charge, used with small arms, fixed, and semifixed ammunition.

*Cartridge storage case.*—A waterproof metal or fiber container in which separate loading propelling charges and igniters are stored, handled, and shipped.

*Casualty agent.*—A chemical agent of such characteristics that a toxic or lethal concentration can be set up under conditions encountered in the field.

*Centrifugal force.*—The force due to rotation. It is used to arm certain fuzes while projectile is in flight.

*Chain.*—Type of pyrotechnic signal in which several colored lights burn in a vertical line.

## AMMUNITION, GENERAL

*Chemical agent.*—A substance which, by its ordinary and direct action, produces a toxic effect, a screening smoke, or an incendiary action. See Gas, Smoke, and Incendiary.

*Cluster.*—(1) A pyrotechnic signal in which a group of stars burns simultaneously. (2) An assembly of several bombs released together.

*Complete round.*—All the ammunition components necessary to fire a weapon once.

*Cordite.*—A double-base propellant powder.

*Creep action.*—The tendency of fuze parts in a moving projectile to move forward.

*Cut (applied to time fuzes.)*—To set (a fuze).

*Data card.*—See Ammunition data card.

*Day of supply.*—The estimated average expenditure of various items of supply per day in campaign, expressed in quantities of specific items or in pounds per man per day.

*Decontamination.*—The act of removing or neutralizing chemical agents from material structures and ground.

*Demolition.*—Destruction due to the blast or mining effect of high explosive ammunition.

*Detonation.*—The very rapid explosion of a high explosive.

*Detonator.*—A sensitive explosive used in an explosive train.

*Distance wadding.*—A cardboard cylinder used in fixed ammunition in which the powder does not fill the cartridge case, to keep the propellant powder around the primer.

*Double-base powder.*—A propellant powder containing nitrocellulose and nitroglycerin.

*Drill ammunition.*—Inert or dummy ammunition used for training personnel.

*Dropping safe.*—Releasing an aircraft bomb or flare so that it will not function on impact. Some flares, however, may function on impact, even when dropped safe.

*Dud.*—Explosive ammunition which has failed to function.

*Dummy ammunition.*—See Drill ammunition.

*E. C. Powder.*—A smokeless powder containing inorganic nitrates; used as a bursting charge in fragmentation grenades.

*Equal section charge.*—A propelling charge for separate loading ammunition divided into equal sections.

*Erosion.*—Wearing away of the inner parts of a gun or cannon as the result of mechanical wear and action of powder gases.

*Explosion.*—The sudden generation of a large volume of highly heated gases with resultant pressures.

*Explosive.*—A substance or mixture which may, upon application of heat or shock, undergo a very rapid chemical change producing a great amount of heat and a large volume of gas.

*Explosive D.*—Ammonium picrate, a high explosive.

*Explosive filler.*—The bursting charge of ammunition.

*Explosive train.*—The step-by-step arrangement of explosives from a small charge of sensitive explosive to a large charge of relatively insensitive explosive.

*Extractor groove.*—The groove around the head of the cartridge case to provide a grip for the mechanical extractor of the weapon.

*Extractor rim.*—A rim or flange around the head of a cartridge case to provide a grip for the mechanical extractor of the weapon.

*Filler.*—Contents carried within an ammunition container, explosive, chemical, or inert.

*Firing.*—The act of discharging a weapon in the normal manner.

*Firing pin.*—A pin used to initiate the action of a detonator or primer.

*Firing tables.*—Collection of data, chiefly in tabular form, intended to furnish the ballistic information necessary for conducting the fire of a particular model of gun and mount with specified ammunition.

*Fixed ammunition.*—Ammunition loaded in one operation into the weapon, the cartridge case being permanently attached to the projectile and the propellant not being variable.

*Flare.*—A pyrotechnic used for illumination.

*Flare-back.*—The passing to the rear of unburned gases from the breech of the weapon, resulting in a flame upon contact of the gases with the air.

*Flash.*—See Muzzle flash.

*FNH powder.*—A smokeless propellant powder which is flashless and nonhygroscopic. When used in cannon in which flash occurs, it is termed NH powder.

*Fragmentation.*—The shattering into many fragments of an item of ammunition by its bursting charge.

*Fuze.*—(1) Tube or cord, filled or impregnated with combustible matter, for igniting an explosive charge after a predetermined delay.

(2) A mechanical device designed to initiate the function of ammunition at the time and under the circumstances desired.

*Fuze setter.*—A mechanical device for setting time fuzes for the calculated time interval.

*Fuze wrench.*—A wrench designed to tighten fuzes in a projectile.

## AMMUNITION, GENERAL

- Gas*.—A chemical agent which, in field concentrations, produces a toxic or irritant effect. The term includes irritant smoke.
- Grading*.—The assignment of lots of ammunition to use in specific weapons or the assignment of priority of use.
- Granulation*.—The size and form of grains of propellant powder.
- Grape*.—A seldom used form of projectile which releases or breaks up into several large balls.
- Grenade*.—Explosive or chemical missile thrown by hand, or projected by rifles or other launchers.
- Grenite*.—A nitrostarch explosive.
- Gun*.—A cannon with a long barrel, generally about 35 to 60 calibers long.
- Guncotton*.—Nitrocellulose of high nitration.
- Gunpowder*.—See Black powder.
- Hangfire*.—The temporary failure of a primer, igniter, or propelling charge to function.
- Harassing agent*.—Any chemical agent used to force masking and thus retard military operations.
- High explosive*.—Explosive functioning with high order detonation.
- High order detonation*.—A complete and instantaneous detonation.
- High-pressure test cartridge*.—Small-arms ammunition to proof-test small arms.
- Howitzer*.—A cannon with a medium length barrel, generally about 25 to 35 calibers long.
- Hung bomb*.—A bomb which accidentally remains attached to the airplane after release from the rack, for example, by the arming wire.
- Hung striker*.—A striker of a grenade fuze which failed to strike the primer, resulting in a dud.
- Hygroscopicity*.—The tendency of material to absorb moisture.
- Identification*.—Complete identification of ammunition consists of type, size, manufacturer's symbol, lot number, and grade.
- Igloo*.—A concrete-arch earth-covered magazine.
- Igniter*.—A black powder charge, usually in the form of a pad or core, attached to separate loading propelling charges.
- Illuminating shell*.—Shell used to illuminate an objective. A time fuze acts to release a flare which is suspended by a parachute.
- Incendiary*.—A chemical agent whose principal effect is to generate sufficient heat to cause the ignition of combustible substances with which it is in contact.
- Inertia*.—Property of matter which tends to resist acceleration.



*Initial velocity.*—See Muzzle velocity.

*Instantaneous fuze.*—See Nondelay fuze.

*Interrupter.*—A device in a fuze which prevents the fuze from acting until the projectile leaves the bore of the gun.

*Irritant gas.*—A nonlethal gas characterized by an intensely irritating physiological action.

*Irritant smoke.*—The common designation of a sternutator type of irritant gas that can be disseminated as extremely small solid or liquid particles in the air.

*Lacrimator.*—An irritant that causes copious flow of tears and intense, though temporary, eye irritation.

*Land mine.*—Fuzed ammunition designed to function on land and normally concealed.

*Lands.*—The raised portion of the rifling of guns and cannon.

*Lead azide.*—A high explosive almost as sensitive as mercury fulminate.

*Lifting plug.*—A plug screwed in the nose of unfuzed projectiles and containing an eyebolt or ring on the end.

*Limited standard.*—Item once used and now obsolete except that existing stocks will be used.

*Livens projector.*—A mortar-type weapon used by chemical troops.

*Long delay fuze.*—A fuze designed to function after complete penetration of the target.

*Lot number.*—See Ammunition lot number.

*Low explosive.*—A relatively slow-burning explosive which does not ordinarily detonate.

*Low order detonation.*—An incomplete and relatively slow detonation, being more nearly a combustion than an explosion.

*M series.*—Referring to a series designated by model numbers in distinction to a series designated by mark numbers.

*Magazine.*—Any structure that is used for storing ammunition or explosives.

*Magazine area.*—Area separated from administration and living areas, fenced and guarded, for the location of magazines.

*Malfunction.*—Failure of ammunition to function in a normal or expected manner.

*Mark number.*—A numerical designation for ordnance items preceded by the abbreviation Mk. See Model number.

*Matrix.*—A composition holding balls in place in shrapnel.

*Mechanical time fuze.*—A fuze whose time action is controlled by a clocklike mechanism.

## AMMUNITION, GENERAL

- Mercury fulminate*.—A sensitive high explosive used as a detonator.
- Mine*.—See Land mine; Antitank mine.
- Misfire*.—Failure of a primer or propelling charge to function.
- Model number*.—The standard numerical designation assigned to any item upon its adoption.
- Mortar*.—(1) A cannon with a short barrel, generally 10 to 15 calibers long. (2) A portable smooth-bore, muzzle-loading, trench warfare weapon.
- Mortar ammunition*.—Generally, ammunition used in smooth-bore mortars and having fins for stability in flight.
- Multisection propelling charge*.—A propelling charge for artillery projectiles consisting of more than one section.
- Munitions*.—Ammunition, explosives, and all necessary war materials.
- Muzzle*.—The end of the barrel of a gun from which the bullet or projectile issues.
- Muzzle flash*.—An observable spurt of flame at the muzzle of a gun when firing.
- Muzzle velocity*.—The velocity of the projectile as it leaves the muzzle of the gun. Also called initial velocity.
- NH powder*.—See FNH powder.
- Nitrocellulose*.—A propellant produced by nitrating cotton (cellulose).
- Nitroglycerin*.—A high explosive produced by nitrating glycerin.
- Nitrostarch*.—A high explosive produced by nitrating starch.
- Nomenclature*.—See Standard nomenclature.
- Nondelay fuze*.—A fuze designed to burst the projectile outside a hard surface before penetration or ricochet.
- Nonpersistent gas*.—A chemical agent whose concentration at the point of discharge is not sufficient after 10 minutes to require protection.
- Obturation*.—To stop up or close by the expansion of a part, usually in reference to the sealing of the breech of a gun to prevent the escape of gas to the rear.
- Ogive*.—The front, curved portion of a projectile.
- Penetration*.—The distance to which a projectile sinks into the target at which it is fired.
- Percussion*.—The initiation of an explosive by means of a blow.
- Persistent gas*.—A chemical agent whose concentration at the point of discharge is sufficient after 10 minutes to require protection.
- Photoflash bomb*.—A pyrotechnic, dropped from aircraft, producing a flash sufficiently bright for photographic purposes.
- Powder grains*.—See Granulation.

*Powder rings.*—Increment sections of a propelling charge in the form of rings, for mortar ammunition.

*Powder train.*—Black powder element in a fuze, the time of burning of which controls the functioning of the fuze.

*Practice ammunition.*—Ammunition used for target practice.

*Premature.*—Term applied to a projectile functioning before the desired time.

*Primer.*—A device which functions as an initiator.

*Primer charge.*—A charge of black powder in artillery primers which transmits the flame to the propelling charge.

*Primer-detonator.*—An assembly of a primer, detonator, and sometimes a delay element, used in bombs.

*Primer mixture.*—A small quantity of a sensitive explosive in a primer which acts as an initiator.

*Priming composition.*—See Primer mixture.

*Projectile.*—Any missile projected by means of explosive force from a weapon.

*Propellant.*—The explosive which, upon ignition, propels the projectile from gun or cannon.

*Propelling charge.*—A definite quantity of explosive used as a propellant.

*Pyro powder.*—See Pyrocellulose.

*Pyrocellulose.*—Nitrocellulose, of lower nitration than guncotton, used in smokeless powder propellants.

*Pyrotechnics.*—Ammunition, consisting of chemical mixtures, used as signals and illuminants.

*Quantity-distance tables.*—Data for the proper and safe storage of ammunition and explosives.

*Rifling.*—The spiral grooving in the bore of a gun or cannon which imparts rotation to the projectile.

*Rotating band.*—A raised copper or gilding metal band near the base of a projectile which imparts rotation to the projectile when engraved by the rifling of a gun.

*Round.*—See Complete round.

*Safe.*—See Dropping safe.

*Salvo.*—One shot per gun, fired simultaneously or fired in a certain order with a specified time interval between rounds.

*Screening agent.*—See Smoke.

*Semifixed ammunition.*—Ammunition loaded into the cannon in one operation and whose propelling charge may be adjusted for zone firing.

## AMMUNITION, GENERAL

- Separate loading ammunition.*—Ammunition the components of which are loaded into cannon separately.
- Service ammunition.*—Ammunition used or intended for use in combat.
- Service markings.*—Painting, stenciling, and stamping on ammunition to impart information necessary for intelligent handling, storage, and use.
- Set-back.*—The effect of inertia on the components of a projectile on firing.
- Shell.*—A hollow projectile. It may contain explosive, chemical, or inert filler, or no filler.
- Short delay fuze.*—A fuze designed to function projectiles after ricochet or before complete penetration in hard ground.
- Shot.*—A projectile which is solid or contains no bursting charge. Also applied to some armor-piercing projectiles containing a reduced explosive charge.
- Shot shell.*—See Shotgun shell.
- Shotgun shell.*—Small-arms ammunition containing small balls or shot which scatter upon firing.
- Shrapnel.*—An artillery projectile containing small balls which are expelled from the shell body when its time fuze functions.
- Signals.*—Pyrotechnics projected from ground or aircraft to produce colored lights.
- Single-base powder.*—A propellant powder containing nitrocellulose as its base, also known as straight nitrocellulose powder.
- Slivers.*—Unburned fragments of multiperforated powder grains ejected from a cannon during firing.
- Small arms.*—Rifles, automatic rifles, pistols, and machine guns up to caliber .60, and shotguns.
- Small-arms ammunition.*—Ammunition fired from small arms.
- Smoke.*—A chemical agent which, when released from its container, spreads through the atmosphere in the form of liquid or solid particles producing an obscuring fog.
- Smokeless powder.*—Nitrocellulose propellant powders.
- Spider.*—In an antitank mine, the device for functioning the fuze.
- Square-base.*—Portion to the rear of the rotating band of a projectile, which is cylindrical rather than tapered.
- Stacked.*—Arrangement of powder grains end to end instead of at random in a separate loading propelling charge.
- Standard contour fuzes.*—Point-detonating fuzes having standard shape, size, and weight.
- Standard nomenclature.*—A specific descriptive name by which each ordnance item or assembly is designated. Used in all official reference to the item or assembly.

*Star*.—A pyrotechnic signal which burns as a single light.

*Sternutator*.—A chemical agent which, when breathed in extremely low concentrations, causes coughing, sneezing, or headache, followed by nausea, and temporary physical debility.

*Strip powder*.—Smokeless powder manufactured in the form of strips.

*Subcaliber ammunition*.—Ammunition used with subcaliber mounts and tubes, that is, weapons of small caliber used to simulate the firing of the larger caliber weapon.

*Superquick fuze*.—A fuze designed to function immediately upon impact.

*Supersensitive fuze*.—A fuze designed to function on impact with a very light target, such as an airplane wing.

*Surveillance*.—All steps necessary for the maintenance of ammunition stores in usable condition. It includes inspection, testing, and maintenance.

*Target practice ammunition*.—See Practice ammunition.

*Tetryl*.—A sensitive explosive which is standard for use in boosters and bursters.

*Thermit*.—A mixture producing molten iron upon ignition; used as an incendiary agent.

*Time fuze*.—A fuze designed to function a predetermined time interval after firing.

*Toxic*.—A substance which, acting through its chemical properties and by its ordinary action, produces a harmful physiological reaction when applied to the body externally, when breathed, or when taken in small doses internally. All war gases are toxic.

*Tracer*.—A burning composition placed in shell and bullets which shows the path of the projectile.

*Trajectory*.—The curve in space traced by a projectile in flight.

*Trench mortar*.—A smooth-bore portable mortar.

*Trimonite*.—A high explosive used as a substitute for TNT as a bursting charge.

*Trinitrotoluene (TNT)*.—A high explosive which is the standard bursting charge for ammunition.

*Triton block*.—Block of TNT used for demolition purposes.

*Unequal section charge*.—A propelling charge divided into a number of unequal sections, as three  $\frac{1}{4}$  sections and two  $\frac{1}{8}$  sections.

*Unequal related section charge*.—See Unequal section charge.

*Unfixed shell*.—Shell for fixed ammunition which are loaded but not yet assembled to cartridge case. Stored as separate loading shell.

## AMMUNITION, GENERAL

*Unit of fire.*—An arbitrary unit of measure for ammunition supply representing a specified number of rounds per weapon.

*Using arms.*—The branches of the Army which habitually use or expend the particular ammunition under discussion.

*Very pistol.*—A type of pistol for firing light signals.

*Vesicant.*—A chemical agent which produces inflammation, burns, and the destruction of tissue.

*Weapon.*—An instrument of combat; anything used physically against an enemy such as a gun, sword, shield, grenade, etc.

*Web.*—Minimum thickness between two adjacent perforations, or between perforation and edge, of a powder grain.

*Weight zone.*—A grouping of a number of shell of the same weight and same lot number for accuracy in firing.

*Zone of fire.*—An area of a certain range determined by considering weight of projectile and quantity of propelling charge.

*Zone, weight.*—See Weight zone.

## APPENDIX II

### ABBREVIATIONS

AA	Antiaircraft
AM	Amatol
Am	Ammunition
AP	Armor-piercing; amber star parachute
AR	Army Regulations
AT	Antitank
Auto	Automatic
BD	Base detonating
BDF	Base-detonating fuze
BT	Bombing table
C1	First change
cal.	Caliber
CG	Phosgene
cml.	Chemical
chg.	Charge
C. I.	Center of impact; cast iron
Cl	Chlorine
CN	Chloracetophenone (Tear gas)
c/r (C. R.)	Complete Round
C. R. C.	Complete Round Chart
C. S. C.	Cartridge storage case
CWS	Chemical Warfare Service
Demo.	Demolition
diam.	Diameter
DM	Adamsite, sneeze gas
DP	Deck-piercing
drg. (dwg)	Drawing
Exp. (Ex.)	Explosive
FM	Field Manual; titanium tetrachloride, smoke
FNH	Flashless, nonhygroscopic
Frag.	Fragmentation
FSMWO	Field Service Modification Work Order
Gn	Gun
GH	Gun or howitzer
gr.	Grain
HE	High explosive
HEI	High explosive incendiary

## AMMUNITION, GENERAL

How	Howitzer
HS	Mustard gas
ICC	Interstate Commerce Commission
IMR	Improved military rifle
in.	Inch
lb.	Pound
LD	Long delay
LE	Low explosive
LP	Livens projector
M	Model; manufacture to be continued; mortar
M1	Lewisite
Mk.	Mark
mech.	Mechanical
mm	Millimeter
Mod.	Modification
MV	Methyl violet; muzzle velocity
NC	Nitrocellulose
ND	Nondelay
NG	Nitroglycerin
NH	Nonhygroscopic
obs.	Obsolete
OFSB	Ordnance Field Service Bulletin
OFSC	Ordnance Field Service Circular
OO (O. O.)	Ordnance Office
OPSI	Ordnance Publications for Supply Index
OSM	Ordnance Safety Manual
OTCM (OCM)	Ordnance Technical Committee Minutes
oz.	Ounce
PD	Point-detonating
PDF	Point-detonating fuze
pdr.	Powder; pounder (15-par.)
perc.	Percussion
proj.	Projectile
PS	Chlorpicrin
rd. (rds.)	Round(s)
S	In SNL's, in stock for issue and manufacture discontinued; on shell, smoke producer together with HE filler
SD	Short delay
SDT	Shell destroying tracer
sec.	Second
SNL	Standard Nomenclature List
SP	Smokeless powder



SQ	Superquick
T	Tentative model designation
T/A	Table of allowances
T/BA	Table of Basic Allowances
TH	Thermit
TM	Technical Manual; Training Manual
TNT	Trinitrotoluene
TP	Target practice; tank piercing
TR	Technical Regulations; Training Regulations
w/	With
WD	War Department
w/o	Without
WP	White phosphorus; white star parachute

APPENDIX III

LIST OF REFERENCES

<b>1. Standard Nomenclature Lists.—a. Ammunition for small arms.</b>	
Ammunition, revolver and automatic pistol.....	SNL T-2
Ammunition, rifle and automatic gun.....	SNL T-1
Ammunition, small arms, obsolete, and nonstandard...	SNL T-6
Miscellaneous service components of small-arms ammunition and instruction material for field service account.....	SNL T-4
Shells, shotgun.....	SNL T-3
<i>b. Bombs, grenades, and pyrotechnics.</i>	
Ammunition instruction material for grenades, pyrotechnics, and aircraft bombs.....	SNL S-5
Bombs, aircraft, all types.....	SNL S-1
Grenades, hand and rifle.....	SNL S-3
Grenades, pyrotechnics, and aircraft bombs.....	SNL S-6
Pyrotechnics, military, all types.....	SNL S-4
<i>c. Cleaning, preserving, and lubricating materials.</i>	
<i>d. Firing tables and trajectory charts.</i>	
<i>e. Harbor defense, heavy field, and railway artillery.</i>	
Ammunition, fixed, including subcaliber ammunition...	SNL P-4
Ammunition instruction material.....	SNL P-7
Ammunition, obsolete, and nonstandard.....	SNL P-9
Charges, propelling, separate loading.....	SNL P-3
Fuzes, primers, blank ammunition, and miscellaneous items.....	SNL P-6
Projectiles, separate loading.....	SNL P-1
<i>f. Pack, light, and medium field artillery.</i>	
Ammunition, blank.....	SNL R-5
Ammunition, fixed, all types.....	SNL R-1
Ammunition, instruction material.....	SNL R-6
Ammunition, obsolete, and nonstandard.....	SNL R-8
Ammunition, trench mortar, including fuzes, propelling charges, and other components.....	SNL R-4
Ground mines and fuzes, demolition matériel for use in policing target ranges, and ammunition for simulated artillery and grenade fire.....	SNL R-7

Projectiles and propelling charges, separate loading, all types.....	SNL R-2
Service fuzes and primers.....	SNL R-3
Current Standard Nomenclature Lists are as tabulated here. An up-to-date list of SNL's is maintained as the "Ordnance Publications for Supply Index".....	OPSI
<b>2. Explanatory publications.—a. Ammunition, all types.</b>	
Ammunition, general.....	OFSB 3-1
Ammunition—reimbursement prices.....	OFSB 3-7
Ammunition nomenclature and shipping names.....	OFSB 3-12
Ammunition condition report.....	O. O. 7235
Explosives and demolitions.....	FM 5-25
Military explosives.....	TM 9-2900
Qualifications in arms and ammunition training allowances.....	AR 775-10
Range regulations for firing ammunition in time of peace.....	AR 750-10
Unsafe ammunition.....	OFSB 3-11
<b>b. Ammunition, special types.</b>	
Field artillery and field mortar ammunition.....	OFSB 3-3
60-mm mortar M2.....	FM 23-85
81-mm mortar M1.....	FM 23-90
Mortar ammunition.....	TM 9-1935
Seacoast, railway, antiaircraft and field artillery ammunition.....	OFSB 3-2
Small-arms ammunition.....	TM 9-1990
Small-arms ammunition.....	OFSB 3-5
<b>c. Bombs, grenades, and pyrotechnics.</b>	
Aircraft bombs and bomb components.....	OFSB 3-7
Bombs for aircraft.....	TM 9-1980
Grenades.....	TM 9-1985
Grenades.....	OFSB 3-10
Hand grenades.....	FM 23-30
Military pyrotechnics.....	TM 9-981
<b>d. Cleaning, preserving, lubricating, and welding materials.....</b>	
	TM 9-850
<b>e. Miscellaneous.</b>	
Defense against chemical attack.....	FM 21-40
Inspection of propelling charges and bulk powder.....	OFSB 3-13
List of publications for training.....	FM 21-6
Magazine placard.....	O. O. 5991

## AMMUNITION, GENERAL

Military chemistry and chemical agents.....	TM 3-215
Military sanitation and first aid.....	FM 21-10
Ordnance Field Manual.....	FM 9-5
Ordnance safety manual.....	O. O. 7224
<i>f. Prescribed regulations.</i>	
Administration; posts, camps, and stations.....	AR 210-10
Fire protection and fire fighting.....	AR 30-1580
Honors to persons.....	AR 600-30
List of current pamphlets and changes; distribution...	AR 1-10
Lost, destroyed, damaged, or unserviceable property...	AR 35-6640
Ordnance field service in time of peace.....	AR 45-30
Salutes and ceremonies.....	AR 600-25
Supplies, storage, and issue.....	AR 700-10
Transportation by commercial means; general.....	AR 30-905
Transportation of supplies.....	AR 30-955
Transportation by water of explosives, inflammables, and chemical warfare materials.....	AR 30-1270

## INDEX

	Paragraph	Page
Abbreviations.....	App. II	194
Accidents, reports of.....	147	157
Adamsite.....	38	20
Adapter-boosters.....	81	54
Adapters.....	81	54
Aircraft—		
Bombs. (See Bombs.)		
Flares.....	103	90
Signals.....	105, 106	91, 92
Airport flares.....	103	90
Aliquot part propelling charges.....	82	54
Allways fuze.....	73	46
Alteration of ammunition.....	146	155
Amatol.....	27	15
Ammonal.....	34	18
Ammonium picrate (explosive D).....	28	16
Destroying.....	160	173
Antitank mines.....	65-70	38
Destroying.....	172	180
Storage.....	116	112
Arming of fuzes.....	80	53
Armor-piercing—		
Bombs.....	91	76
Cap.....	79	51
Cartridges.....	44	27
In demonstrations.....	148	158
Projectile.....	79	51
Artillery ammunition.....	76-87	49
Destroying.....	161, 162	173, 184
Marking.....	8, 87, 137	5, 58, 142
Precautions for practice firing.....	149	159
Packing.....	87, 149	58, 259
Ball cartridges.....	43	27
Ballistite.....	18, 22	10
Base—		
And increment propelling charges.....	82	54
Cover.....	79	51
Detonating fuze.....	79	51
Plug.....	79	51
Base:		
Boat-tailed.....	79	51
Square.....	79	51
Black powder.....	23	11
Destroying.....	160	173
Inspection.....	124	237
Precautions.....	23	11
Storage.....	118	124
Use.....	23	11

## INDEX

	Paragraph	Page
Blank—		
Ammunition.....	6, 85	4, 57
Destroying.....	163	175
Precautions.....	150	163
Storage.....	116	112
Cartridges.....	46	27
Firing.....	148	158
Blasting caps, storage.....	116	112
Blending of propelling charges.....	149	159
In harbor defenses.....	154	165
Boat-tailed base.....	79	51
Body, projectile.....	79	51
Bomb clusters.....	92	77
Bombs.....	88-98	75
Destroying.....	164	175
Inspection.....	124, 126	137, 138
Marking.....	98, 137	78, 142
Photoflash.....	104	91
Destroying.....	170	178
Storage.....	116	112
Precautions for practice firing.....	152	165
Storage.....	116, 118	112, 124
Boosters.....	81	54
Storage.....	116, 118	112, 124
Bore-safe fuzes.....	80	53
Bourrelet.....	79	51
Boxes, packing.....	134	140
Bullets.....	41	26
Lodged in bore of weapon.....	148	158
Bureau of Explosives.....	141	145
Bursters.....	81	54
Storage.....	116, 118	112, 124
Bursting—		
Charge explosive train.....	25	14
Charges. (See High explosives.)		
Caliber.....	79	51
Camouflage in field parks and dumps.....	155	166
Canister.....	79	51
Cannon primers. (See Primers.)		
Car certificate.....	142	147
Care and precautions in handling—		
Ammonium picrate.....	28	16
Antitank mines.....	69	40
Artillery ammunition.....	86	57
Black powder.....	23	11
Blank ammunition.....	151	163
Bombs.....	97, 152	78, 165
Chemical ammunition.....	147	157
Duds.....	147, 173	157, 180
Fuzes.....	149	159
Grenades.....	63, 151	38, 163

Care and precautions in handling—Continued.	Paragraph	Page
Igniters.....	149	159
Mortar ammunition.....	74, 153	47, 165
Propelling charges.....	149	159
Pyrotechnics.....	109, 151	93, 163
Small-arms ammunition.....	55, 56	28, 29
Care, handling, and preservation.....	11, 111-157	7, 102
Cartons, packing.....	134	140
Cartridge bags.....	82	54
Cartridge storage cases.....	118, 134	124, 140
Cartridges.....	41-52	26
Armor-piercing, in demonstrations.....	148	158
Casualty agents.....	36	19
Certified car.....	142	147
Chemical—		
Agents.....	35-39	19
Ammunition:		
At supply points.....	157	168
Destroying.....	171	179
Inspection.....	129	138
Marking and painting.....	37	20
Precautions in practice firing.....	151	163
Storage.....	116, 118	112, 124
Bombs.....	93	77
Grenades.....	60	35
Shell.....	79	51
Chloracetophenone.....	38	20
Chlorine gas.....	38	20
Chlorpicrin.....	38	20
Classification of ammunition.....	6	4
Clusters, bomb.....	92	77
Colors—		
Of markings.....	137	142
Of other than small-arms ammunition.....	8	5
Of small-arms ammunition.....	8	5
Combination percussion-electric primer.....	83	56
Combined storage.....	117	121
Complete round.....	76	49
Components, small, destroying.....	167	176
Containers, packing, marking on.....	137	142
Crates, packing.....	134	140
Cyclonite.....	34	18
Data card and tag.....	7, 139	4, 144
Date of inspection.....	121	134
Decontamination.....	39	24
Defective ammunition, report of and inspection of.....	131	139
Defects in ammunition.....	146, 147	155, 157
Delay fuze.....	80	53
Demolition—		
Blocks, storage.....	116	112
Bombs.....	90	76

INDEX

	Paragraph	Page
Destroying ammunition, explosives, and duds.....	158-173	169
Detonators, storage of.....	118	124
Double-base powders.....	18	10
Drift signals.....	106	92
Drill—		
Ammunition.....	6	4
Storage.....	118	124
Bombs.....	95	78
Projectiles.....	79	51
Dropping safe.....	88, 103	75, 90
Duds.....	148	158
Destroying.....	158, 173	169, 180
Dummy—		
Ammunition.....	6	4
Cartridges.....	52	28
Propelling charges.....	82	54
Dumping ammunition at sea.....	158	169
Dynamite:		
Inspection.....	124	137
Storage.....	118	124
E.C. blank fire.....	21	10
E.C. smokeless powder.....	21	10
Electric primers.....	83	56
Emergency landing flares.....	103	90
Equal section propelling charges.....	82	54
Examination:		
Ammunition for defects.....	146	155
Artillery ammunition.....	149	159
Small-arms ammunition.....	148	158
Explosive D. (See Ammonium picrate.)		
Explosive train:		
Bursting charge.....	25	14
Propelling charge.....	14	8
Explosives:		
Destroying.....	158, 160	169, 173
General.....	13	8
High.....	13, 24-34	8, 14
Inspection.....	124	137
Low.....	13-23	8
Maximum quantity in magazine.....	116	112
Storage.....	116-118	112
Extracting artillery ammunition.....	149	159
Exudation of ammunition.....	26, 125	14, 137
Eyebolt lifting plug.....	87	58
Field parks and dumps, ammunition in.....	155-157	166
Fire—		
Fighting and protection.....	113	104
In field parks and dumps.....	155	166
In motor truck shipments.....	144	150



	Paragraph	Page
Fire—Continued.		
Precautions, safety.....	111	102
Prevention, special rules.....	113	104
Fires, causes of.....	113	104
Firing—		
Blank cartridges.....	148	158
Line, ammunition on.....	145-153	155
Precautions—		
Before firing.....	146	155
During and after firing.....	147	157
Through trees.....	147	157
First-fire compound.....	102	89
Fixed ammunition.....	76	49
Inspection.....	122	135
Storage.....	118	124
Flareback.....	149	159
Flares.....	103	90
Destroying.....	170	178
FNH powder.....	19	10
Fragmentation—		
Bombs.....	92	77
Grenades.....	59	35
Friction primers.....	83	56
Fuzes:		
Allways.....	73	46
Antitank mine.....	67	38
Artillery.....	80	53
Arming.....	80	53
Assembling.....	149	159
Base-detonating.....	79	51
Storage.....	116-118	112
Bore-safe.....	80	53
Definition.....	80	53
Handling.....	149	159
Point-detonating, storage.....	146	112
Bomb.....	88	75
Storage.....	116	112
Grenade, storage.....	116-118	112
Inspection.....	127	138
Mortar ammunition.....	73	46
Shipping, with other explosives.....	144	150
Storage.....	118	124
Gallery practice cartridges.....	47	27
Gas.....	36	19
Irritant.....	38	20
Nonpersistent.....	38	20
Persistent.....	38	20
General purpose bombs.....	90	76
Glossary.....	App. I	182
Grading.....	9	6

## INDEX

	Paragraph	Page
Grenades.....	58-64	35
Destroying.....	169	178
On the firing line.....	151	163
Storage.....	116-118	112
Grenite.....	30	17
Grommet.....	87	58
Ground signals.....	107	92
Guard—		
Cartridges.....	47, 48	27
Protection.....	112	103
Guncotton.....	20	10
Hand grenades. (See Grenades.)		
Handling. (See Care, handling, and preservation; Care and precautions in handling; Safety precautions.)		
Hangfire of small-arms ammunition.....	148	158
Harassing agents.....	36-38	19
Harbor defenses, ammunition in.....	154	165
Hexachlorethane-zinc mixture.....	38	20
High-explosive shell.....	79	51
High explosives.....	13, 24-34	8, 14
Storage.....	116-118	112
High-pressure test cartridge.....	50	28
Hung bomb.....	97	78
Identification.....	7, 8, 137	4, 5, 142
Artillery ammunition.....	78	50
Bombs.....	89	76
Color schemes.....	8, 137	5, 142
Lot number.....	7, 138	4, 144
Marking. (See Marking.)		
Model number.....	7	4
Painting. (See Marking.)		
Small-arms ammunition.....	8, 148	5, 158
Igniter protector cap.....	84	57
Igniters.....	14, 84	8, 57
Handling.....	149	159
Marking for location of.....	137	142
Igniting primer.....	83	56
Impact fuze.....	80	53
Incendiaries.....	36-38	19
Incendiary cartridges.....	45	27
Inert components:		
Inspection.....	130	139
Storage.....	118	124
Inhabited building, definition.....	116	112
Inspection:		
Date.....	121	134
Definition.....	119	134
Inspection and surveillance.....	119-132	134
Interstate Commerce Commission Regulations.....	141	145

INDEX

	Paragraph	Page
Irritants.....	36	19
Gas.....	38	20
Smoke.....	38	20
Issue of ammunition:		
At firing point.....	146	155
Priority of.....	10	7
Lacrimators.....	36-38	19
Land mine. (See Antitank mine.)		
Lead azide.....	33	18
Lewisite.....	38	20
List of references.....	App. III	197
Loading—		
Artillery ammunition.....	149	159
Shell in harbor defenses.....	154	165
Lot number.....	7, 138	4, 144
Low explosives.....	13-24	8
Storage.....	116	112
Magazine and magazine areas.....	114-118	108
Care and maintenance.....	115	110
Inspection.....	120	134
Maintenance, definition.....	119	134
Malfunctioning—		
Of ammunition.....	147	157
Of small-arms ammunition.....	148	158
Mark number.....	7	4
Marking.....	7, 8, 133-139	4, 5, 139
Antitank mines.....	70	41
Artillery ammunition.....	87, 137	58, 142
Bombs.....	90, 98, 137	76, 78, 142
Chemical ammunition.....	37	20
Color.....	8, 137	5, 142
Containers, packing.....	137	142
For shipment.....	12	7
Grenades.....	63	38
Identification. (See Identification.)		
Igniters.....	137	142
Lot number.....	7	4
Model number.....	7	4
Mortar ammunition.....	75	49
Packages.....	137	142
Pyrotechnics.....	110, 137	93, 142
Regulations.....	133	139
Small-arms ammunition.....	57, 137	30, 142
Maximum quantity of explosives in magazine.....	116	112
Mercury fulminate.....	32	18
Use.....	32	18
Methyl violet test paper.....	121	134
Mines. (See Antitank mines.)		

## INDEX

	Paragraph	Page
Misfire:		
Artillery ammunition.....	149	159
Small-arms ammunition.....	56, 148	29, 158
Model number.....	7	4
Mortar ammunition.....	71-75	46
Destroying.....	165	176
On the firing line.....	153	165
Storage.....	116-118	112
Motor truck shipments.....	144	150
Multisection propelling charges.....	82	54
Mustard gas.....	38	20
National Match cartridges.....	51	28
Navigable stream, definition.....	116	112
Nearest magazine, definition.....	116	112
New construction.....	115	110
NH powder.....	19	10
Night bombing flares.....	103	90
Nitrocellulose powders.....	15-17	9
Nitroglycerin.....	18, 19	10
Nitrostarch explosives.....	30	17
Nomenclature Lists, Standard.....	5	3
Nonpersistent gas.....	38	20
Normal charge.....	149	159
Obturation.....	41	26
Ogive.....	79	51
Packages, marking.....	137	142
Packing.....	12, 133-136	7, 139
Antitank mines.....	70	41
Artillery ammunition.....	87, 149	58, 159
At the firing point.....	146	155
Bombs.....	98	78
Boxes.....	134	140
Containers, marking.....	137	142
Crates.....	134	140
Grenades.....	63	38
Mortar ammunition.....	75	49
Projectiles—		
In freight cars.....	142	147
In motortrucks.....	144	150
Pyrotechnics.....	110	93
Small-arms ammunition.....	57	30
Painting. (See Marking.)		
Percussion primer.....	83	56
Persistent gas.....	38	20
Personnel, protection of.....	111, 147	102, 157
Phosgene.....	38	20
Phosphorus.....	38	20
Photoflash bombs. (See Bombs, photoflash.)		
Picric acid.....	29	16

INDEX

	Paragraph	Page
Pistol, pyrotechnic.....	103	90
Placing ammunition at the firing point.....	146	155
Point-detonating fuze.....	79	51
Practice—		
Ammunition.....	6	4
Storage.....	118	124
Bombs.....	94	77
Precautions. (See Care and precautions in handling; Safety precautions.)		
Preservation. (See Care, handling, and preservation.)		
Pressures, erratic and excessive.....	149	159
Primacord Bickford.....	26	49
Primer-detonators:		
Marking for location of.....	137	142
Storage.....	116-118	112
Primers.....	14, 25	8, 14
Cannon.....	83	56
Destroying.....	168	177
Small-arms.....	41	26
Storage.....	116-118	112
Priority of issue.....	10	7
Projectiles.....	79	51
Packing—		
In freight cars.....	142	147
In motortrucks.....	144	150
See also Shell and Artillery ammunition.		
Propellants.....	13-24	8
Propelling charges:		
Base and increment type.....	82	54
Blending.....	149	159
In harbor defenses.....	154	165
Cartridge storage cases.....	118	124
Colors.....	82, 137	54, 142
Dummy.....	82	54
Equal section type.....	82	54
Erratic and excessive pressures.....	149	159
Explosive train.....	14	8
On the firing line.....	149	159
Multisection.....	82	54
Normal charge.....	149	159
Premature ignition.....	149	159
Separate loading:		
Destroying.....	161	173
Inspection.....	121	134
Single section.....	82	54
Small-arms.....	41	26
Storage.....	116-118	112
Supercharge.....	149	159
Unequal section type.....	82	54
Protection of personnel.....	147	157
Public railway, definition.....	116	117

## INDEX

	Paragraph	Page
Publication file pertinent to inspection.....	132	139
Pyro powder.....	15, 17	9, 10
Pyrocellulose.....	17	10
Pyrotechnic—		
Compositions.....	101	89
Pistol.....	103	90
Pyrotechnics.....	99-110	89
Destroying.....	170	178
Inspection.....	128	138
Marking.....	137	142
On the firing line.....	151	163
Serviceable life.....	128	138
Storage.....	109, 116-118	93, 112
Quantity-distance tables.....	116	112
<i>See also</i> Storage.		
Rail shipments.....	142	147
Ranges, maximum.....	149	159
Reconnaissance flares.....	103	90
References.....	App. III	197
Renovating shell in harbor defenses.....	154	165
Repairs to magazines.....	115	110
Reports of accidents, malfunctions, defects.....	147	157
Rotating band.....	79	51
Round.....	76	49
Safe, dropping.....	88, 103	75, 90
Safety precautions.....	111-113	102
Before firing.....	146	155
Containers.....	111	102
Destroying ammunition, explosives, duds.....	159	171
During and after firing.....	147	157
Fire.....	111, 113	102, 104
Handling ammunition.....	111	102
Personnel.....	111	102
Target ranges.....	173	180
Safety zones.....	146	155
Saluting charges, storage.....	118	124
Screening—		
Agents.....	36	19
Smokes.....	38	20
Sealing packings.....	136	142
Semifixed ammunition.....	76	49
Inspection.....	122	135
Storage.....	116-118	112
Separate loading—		
Ammunition.....	76	49
Propelling charges. ( <i>See</i> Propelling charges, separate loading.)		
Shell. ( <i>See</i> Shell, separate loading.)		

INDEX

	Paragraph	Page
Service ammunition.....	6	4
Set back.....	80	53
Shell:		
Chemical.....	79	51
Destroying.....	162	174
High explosive.....	79	51
In harbor defenses.....	154	165
Reconditioning.....	125	137
Shotgun.....	53	28
Storage.....	116-118	112
<i>See also</i> Projectile.		
Shipping.....	140-144	145
Labels.....	137	142
Packing and marking.....	12	7
Tags.....	137	142
Shotgun shell.....	53	28
Shrapnel.....	79	51
Storage.....	116	112
Signals:		
Aircraft.....	105	91
Drift.....	106	92
Ground.....	107	92
Very light.....	108	92
Simulated agents.....	36	19
Single section propelling charges.....	82	54
Small-arms ammunition.....	40-57	25
Destroying.....	166	176
Identification.....	148	158
Color scheme.....	8	5
Inspection.....	123	136
Malfunctioning.....	148	158
Marking.....	57, 137	30, 142
Propellants.....	22	10
Storage.....	116-118	112
Smoke-puff ammunition:		
Inspection.....	124	137
On the firing line.....	150	163
Storage.....	118	124
Smokeless powder.....	15, 16	9
Destroying.....	160	173
Inspection.....	121	134
Storage.....	116-118	112
Smokes.....	36, 38	19, 20
Sneeze gas.....	38	20
Spotting charges, storage.....	116-118	112
Square base.....	79	51
Standard Nomenclature Lists.....	5	3
Sternutators.....	36, 38	19, 20
Storage.....	114-118, 120	108, 134
Field pack and dumps.....	156	167
Pyrotechnics.....	109, 116-118	93, 112

## INDEX

	Paragraph	Page
Strip powder.....	16	9
Subcaliber—		
Cartridge.....	49	28
Projectile.....	79	51
Substitution of ammunition.....	146	155
Sulfur trioxide-chlorosulfonic acid mixture.....	38	20
Supercharge.....	149	159
Superquick fuze.....	80	53
Supersensitive fuze.....	80	53
Surveillance.....	119-132	134
Target-practice projectile.....	79	51
Target ranges, precautions.....	173	180
Tear gas.....	38	20
Tetryl.....	31	17
Destroying.....	160	173
Thermit.....	38	20
Time fuze.....	80	53
Titanium tetrachloride.....	38	20
TNT (trinitrotoluene).....	26	14
Destroying.....	160	173
Tracer—		
Artillery shell.....	79	51
Cartridge.....	45	27
Trench mortar ammunition. (See Mortar ammunition.)		
Trimonite.....	34	18
Trinitrophenol.....	29	16
Trinitrotoluene.....	26	14
Triton.....	26	14
Trojan explosives.....	30	17
Types of ammunition.....	4, 40	3, 25
Unequal section propelling charges.....	82	53
Unserviceable ammunition:		
Destroying.....	158-173	169
Dumping at sea.....	158	169
Report and inspection.....	131	139
Very light signals.....	108	92
Vesicants.....	36	19
Visibility of pyrotechnic signals.....	102	89
Water shipments.....	143	148
Web size.....	16	9



INDEX

	Paragraph	Page
White phosphorus.....	38	20
Windshield.....	79	51

[A. G. 062.11 (5-11-42).]

BY ORDER OF THE SECRETARY OF WAR:

G. C. MARSHALL,  
*Chief of Staff.*

OFFICIAL:

J. A. ULIO,  
*Major General,*  
*The Adjutant General.*

DISTRIBUTION:

D (2); IBn 9 (2); IC 9 (4).  
(For explanation of symbols see FM 21-6.)