

P1224X

RESTRICTED—Security Information

**DEPARTMENT OF THE ARMY
TECHNICAL MANUAL**

TM 9-2006

**DEPARTMENT OF THE AIR
FORCE TECHNICAL ORDER**

TO 39A-5BA-4

**20-mm
AUTOMATIC GUNS
M24, M24A1
AND
M24E2**

*DEPARTMENTS OF THE ARMY AND THE AIR FORCE
APRIL 1953*

RESTRICTED

RESTRICTED—Security Information

TM 9-2006/TO 39A-5BA-4

This manual supersedes TM 9-232/AFM 136-5, 18 May 1949; TO 39A-5AF-19, 2 June 1952; TO 11-10A-1, 25 November 1949; TO 39A-5A-3, 15 October 1950; and TB 9-232-1/TO 39A-5BA-7, 24 April 1952

20-mm
AUTOMATIC GUNS
M24, M24A1
AND
M24E2



United States Government Printing Office

Washington : 1953

RESTRICTED

RESTRICTED—Security Information

This manual is correct to 30 January 1953

DEPARTMENTS OF THE ARMY AND THE AIR FORCE

WASHINGTON 25, D. C., 1 April 1953

TM 9-2006/TO 39A-5BA-4 is published for the information and guidance of all concerned.

[AG 472.5 (10 Mar 53)]

BY ORDER OF THE SECRETARIES OF THE ARMY AND THE AIR FORCE:

OFFICIAL:
WM. E. BERGIN
Major General, USA
The Adjutant General

J. LAWTON COLLINS
Chief of Staff, United States Army

OFFICIAL:
K. E. THIEBAUD
Colonel, USAF
Air Adjutant General

HOYT S. VANDENBERG
*Chief of Staff, United States Air
Force*

DISTRIBUTION:

Active Army:

Tech Svc (1); Tech Svc Bd (2); AFF (3); AA Comd (2); OS Maj Comd (10); Base Comd (2); MDW (3); Log Comd (5); A (5); CHQ (2); Div (2); Regt 9 (2); Bn 9 (2); CO 9 (2); FT (2); Sch (5) except 9 (50); PMS & T 9 (1); Gen Dep (2); Dep 9 (10); POE (5), OSD (2); PRGR 9 (10); Ars 9 (10); Proc Dist 9 (10); Mil Dist (3); T/O & E's: 5-511 (1); 55-515A (1); 55-516A (1).

NG: Same as Active Army except one copy to each unit.

Army Reserve: Same as Active Army except one copy to each unit.

For explanation of distribution formula, see SR 310-90-1.

CONTENTS

	<i>Paragraphs</i>	<i>Page</i>
CHAPTER 1. INTRODUCTION		
<i>Section</i> I. General.....	1, 2	1
II. Description and data.....	3-7	7
CHAPTER 2. OPERATING INSTRUCTIONS		
<i>Section</i> I. Service upon receipt of materiel.....	8-12	21
II. Operation under usual conditions.....	13-27	23
III. Operation under unusual conditions.....	28-33	50
CHAPTER 3. ORGANIZATIONAL MAINTENANCE INSTRUCTIONS		
<i>Section</i> I. Parts, special tools, and equipment for organiza- tional maintenance.....	34-37	54
II. Lubrication.....	38-43	62
III. Preventive maintenance services.....	44-47	64
IV. Cyclic functioning of weapon.....	48-55	67
V. Functioning of chargers and feed mechanisms.....	56, 57	78
VI. Trouble shooting.....	58-62	91
VII. Cradle group.....	63, 64	93
VIII. Driving spring guide group and rear buffer assembly.....	65-68	95
IX. Breechblock group.....	69-74	99
X. Gas cylinder group.....	75-78	107
XI. Tube and receiver group.....	79-83	109
XII. 20-mm manual charger M6.....	84, 85	124
XIII. 20-mm pneumatic charger M4.....	86, 87	124
XIV. 20-mm feed mechanisms AN-M2, M2E4, and M2E5.....	88, 89	124
CHAPTER 4. FIELD MAINTENANCE INSTRUCTIONS		
<i>Section</i> I. General maintenance.....	90, 91	127
II. Parts, special tools, and equipment for field mainte- nance.....	92-96	128
III. Inspections.....	97, 98	132
IV. Cradle group.....	99-102	137
V. Breechblock group.....	103-105	141
VI. Gas cylinder group (guns M24 and M24E2).....	106-109	145
VII. Gas cylinder group (gun M24A1).....	110-112	146
VIII. Tube and receiver group.....	113-117	148
IX. 20-mm manual charger M6.....	118-120	161
X. 20-mm pneumatic charger M4.....	121-123	167
XI. 20-mm feed mechanisms AN-M2, M2E4, and M2E5.....	124-128	170

RESTRICTED—Security Information

	<i>Paragraphs</i>	<i>Page</i>
CHAPTER 5. AMMUNITION.....	129-138	196
6. SHIPMENT AND LIMITED STORAGE AND DESTRUCTION OF MATERIEL TO PREVENT ENEMY USE		
<i>Section</i> I. Shipment and limited storage.....	139-143	207
II. Destruction of materiel to prevent enemy use....	144, 145	217
APPENDIX REFERENCES.....		220
INDEX.....		223

RESTRICTED—Security Information

This manual supersedes TM 9-232/AFM 136-5, 18 May 1949 (TO 39A-5AF-19, 2 June 1952); TO 11-10A-4, 25 November 1949; TO 39A-5A-3, 15 October 1950; and TB 9-232-1/TO 39A-5BA-7, 24 April 1952

CHAPTER 1

INTRODUCTION

Section I. GENERAL

1. Scope

a. This manual is published for the information and guidance of personnel to whom the materiel is issued and also personnel responsible for performing field maintenance. It contains information on the operation and organizational and field maintenance of the materiel, the use and care of ammunition, domestic shipment and limited storage, and destruction of the materiel to prevent enemy use.

b. The publication of these field maintenance instructions is not to be construed as authority for the performance by organizational maintenance personnel of those functions which have been restricted to field maintenance shops. In general, the prescribed maintenance responsibilities will apply as reflected in the allocation of maintenance parts and tools listed in the current ORD 7 and in the appropriate columns of the current ORD 8 supply catalogs pertaining to these guns. Instructions for field maintenance are to be used by organizational personnel only when the tactical situation makes the repair functions imperative.

c. The appendix contains a list of current references, including supply catalogs, technical manuals, and other available publications applicable to the materiel.

d. This manual differs from TM 9-232/AFM 136-5, 18 May 1949, as follows:

- (1) Adds information on—
 - (*a*) Guns, automatic, 20-mm, M24A1 and M24E2.
 - (*b*) Mechanism, feed, 20-mm, M2E4, left-hand and right-hand.
 - (*c*) Mechanism, feed, 20-mm, M2E5, left-hand and right-hand.
 - (*d*) Machine, hand, link alining, M13.
 - (*e*) Field maintenance.
 - (*f*) Destruction of materiel to prevent enemy use.
- (2) Revises information on—
 - (*a*) Organizational maintenance.
 - (*b*) Trouble shooting.
 - (*c*) Inspection.

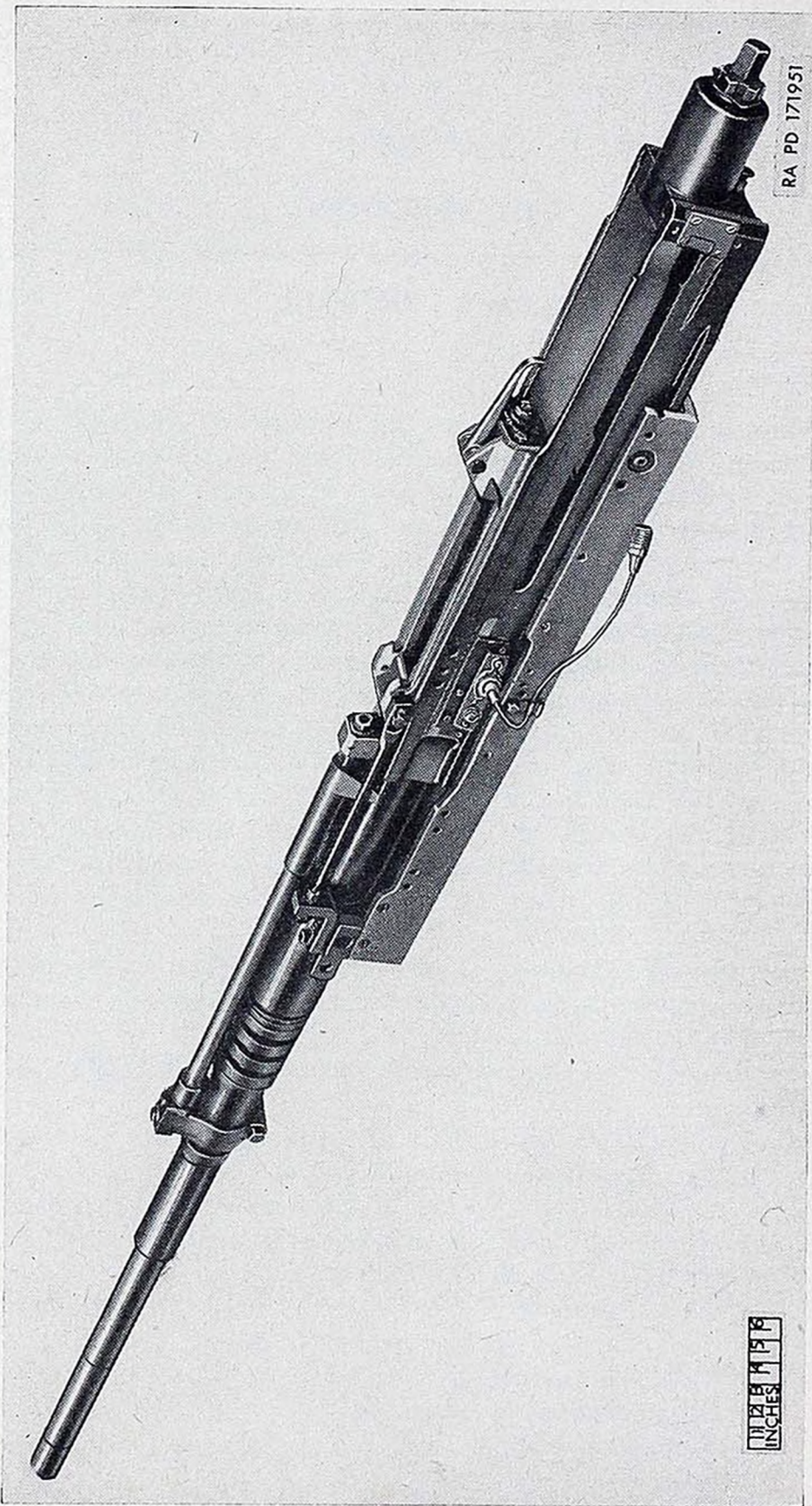

RA PD 171951

Figure 1. 20-mm automatic gun M24 or M24E2—left-side view.

0 1 2 3 4 5 6
INCHES

RA PD 171952

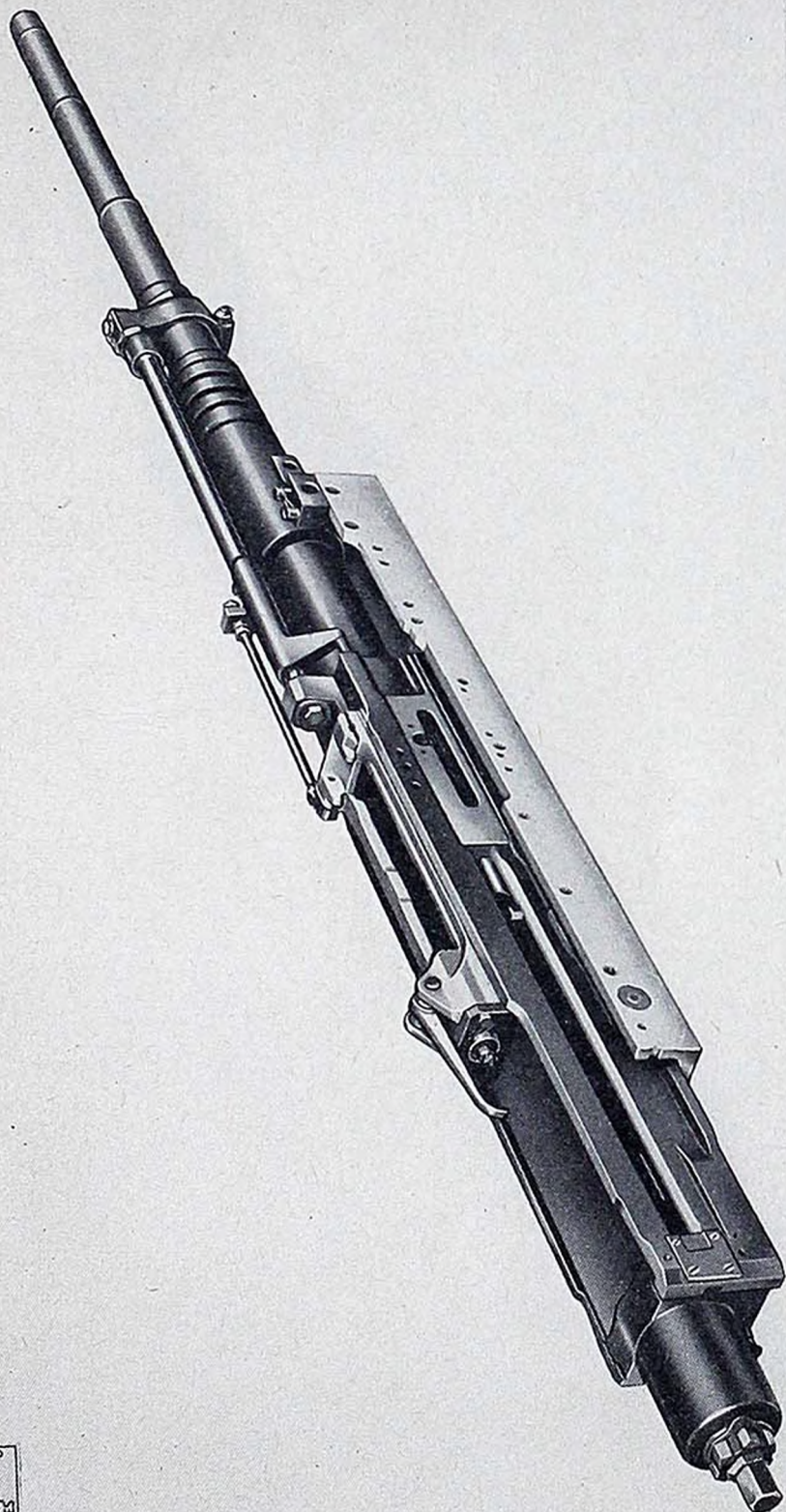

6
INCHES

Figure 2. 20-mm automatic gun M24 or M24E2—right-side view.

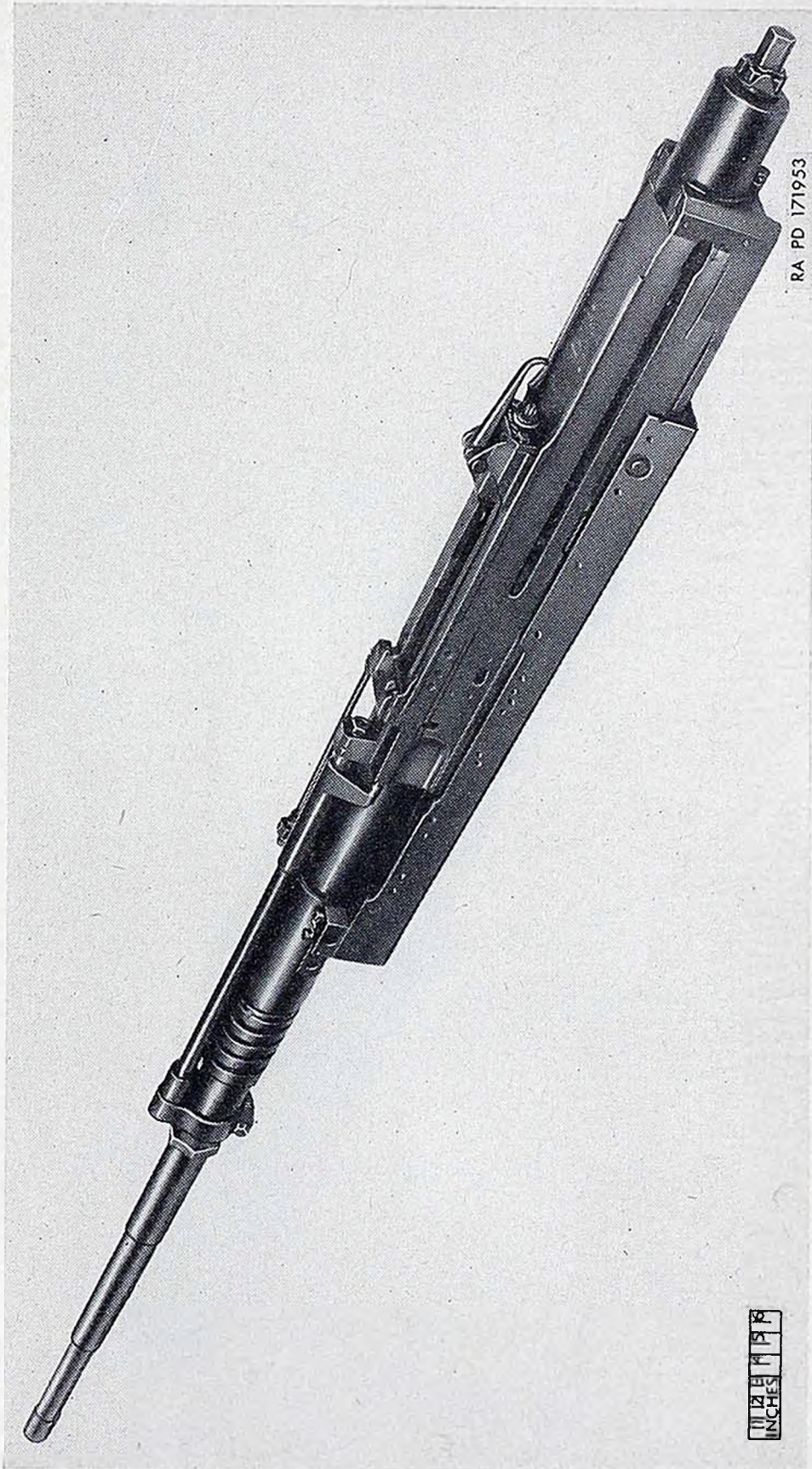

RA PD 171953

Figure 3. 20-mm automatic gun M24A1—left-side view.

INCHES
1 2 3 4 5

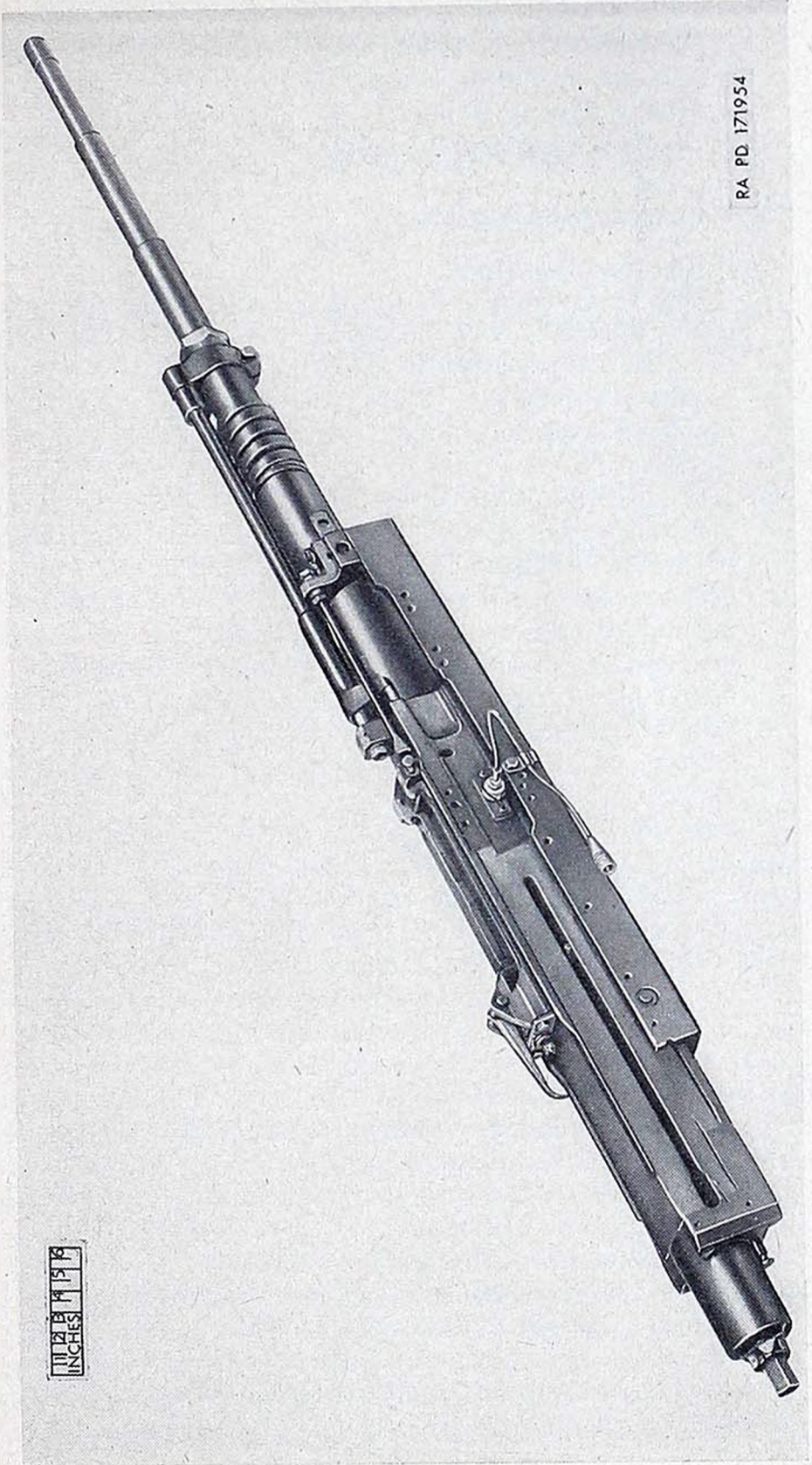

Figure 4. 20-mm automatic gun M24A1—right-side view.

RESTRICTED—Security Information

- (3) Deletes reference to—
- (a) Mechanism, feed, 20-mm, M3, left-hand and right-hand.
 - (b) Charger, hydraulic, 20-mm, M5.
 - (c) Heater, electric, 20-mm, M1.
 - (d) Machine, linking, ammunition, 20-mm, M4.

2. Forms, Records, and Reports

a. *Field Report of Accidents.*

- (1) *Injury to personnel or damage to materiel.* The reports necessary to comply with the requirements of the Army safety program are prescribed in detail in the SR 385-10-40 series of special regulations. These reports are required whenever accidents involving injury to personnel or damage to materiel occur.
- (2) *Ammunition.* When an accident involving the use of ammunition occurs during practice, the incident must be reported as prescribed in SR 385-310-1/AFR 50-13 by the ordnance officer under whose supervision the ammunition is maintained or issued. Where practicable, reports covering malfunctions of ammunition in combat are to be made to the Chief of Ordnance, Washington 25, D. C., ATTN: ORDFM, through channels, giving the type of malfunction, the type of ammunition, the lot number, and the condition under which fired.

b. *Unsatisfactory Report.* Suggestions for improvement in manufacture, design, maintenance, safety, and efficiency of operation, prompted by chronic failure or malfunction of the weapon, spare parts, or equipment, should be reported on AF Form 54 (Unsatisfactory Report) with all pertinent information necessary to initiate corrective action. This form should also be used for reporting complaints on the application or effect of prescribed lubricants and preserving materials, and when so used, it should contain identifying details on both the products and the associated equipment. The report should be forwarded as prescribed in SR 700-45-5 through the Commanding General, Air Materiel Command, Wright-Patterson Air Force Base, Dayton, Ohio, ATTN: UR Control, to the Chief of Ordnance, Washington 25, D. C., ATTN: ORDFM.

c. *Air Force Form 185.* AFR 136-5 establishes and prescribes the use of AF Form 185, Maintenance and Performance Record, Aircraft Automatic Gun, which is to be used by all Air Force activities storing, issuing, operating, or maintaining aircraft automatic guns. AF Forms 185 will remain with the aircraft automatic guns until the guns to which they pertain are disposed of by the Air Force, at which

RESTRICTED—Security Information

time they will be removed by the disposal agency and forwarded to Wright Air Development Center, Wright-Patterson Air Force Base, Dayton, Ohio, ATTN: WCELGH.

Section II. DESCRIPTION AND DATA

3. Description

a. The 20-mm automatic guns M24, M24E2 (figs. 1 and 2), and M24A1 (figs. 3 and 4) are combination blow-back and gas-operated, air-cooled guns designed to fire electric primed fixed ammunition. They are mounted fixed in the wing or fuselage of the aircraft or in flexible mounts in the turret of the aircraft.

b. These guns have a cyclic rate of fire of 700 to 800 rounds per minute except in certain installations where rate is controlled at lower figures. They can be fed from either the right-hand or left-hand side by changing feed mechanisms and repositioning some of the component parts.

4. Differences Among Models

a. General. In order to improve the performance of the 20-mm automatic gun materiel, a number of changes were made in the gun and feed mechanisms. The primary changes in the gun are the addition of bolt retainers for more positive holding of the round during extraction, two-piece driving springs, improved gas system, and improved receiver assemblies. The primary changes in the feed mechanisms are the addition of a heater cartridge, longer link stripper cams, and a link aliner. Details on these and other differences are described in *b* and *c* below.

b. Guns.

(1) *Breechblock group.*

- (*a*) Bolt retainers (fig. 5) have been added for more positive holding of the round or case during extraction.
- (*b*) Breechblock slide plate contacts (fig. 6) have been added to permit a different method of synchronizing guns in some installations.
- (*c*) The breechblock lock (fig. 7) has been strengthened by a change in material and heat treatment. The angles on the side of the lock have also been changed.
- (*d*) The firing pin contact has a flat spring (fig. 7) to insure better contact. Early production guns used the old type round wire (fig. 7).

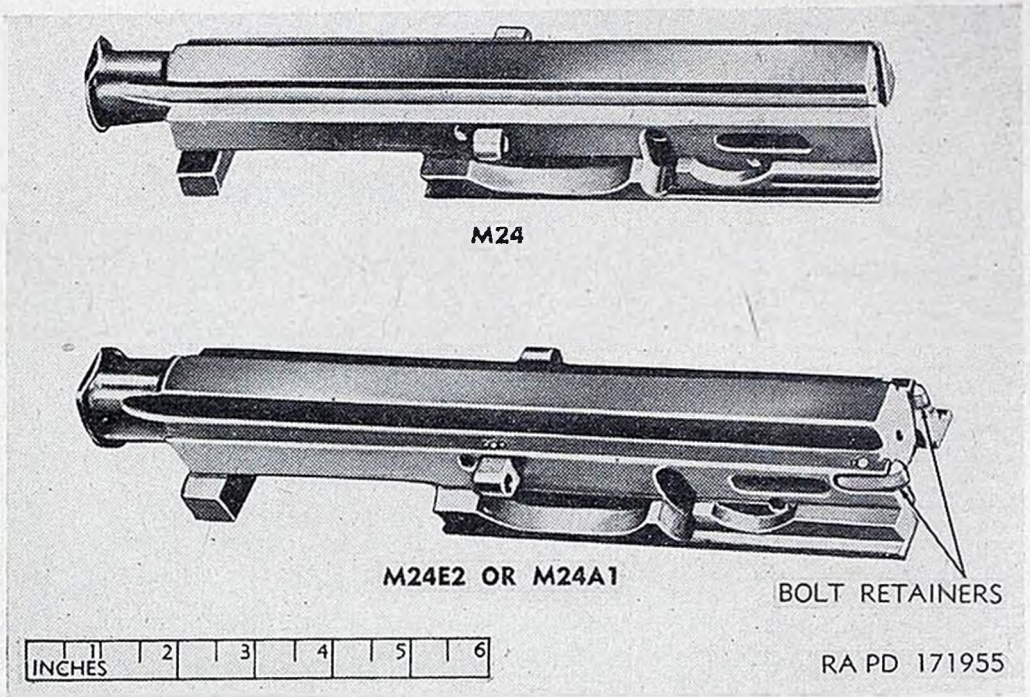

Figure 5. Comparison of bolt assemblies.

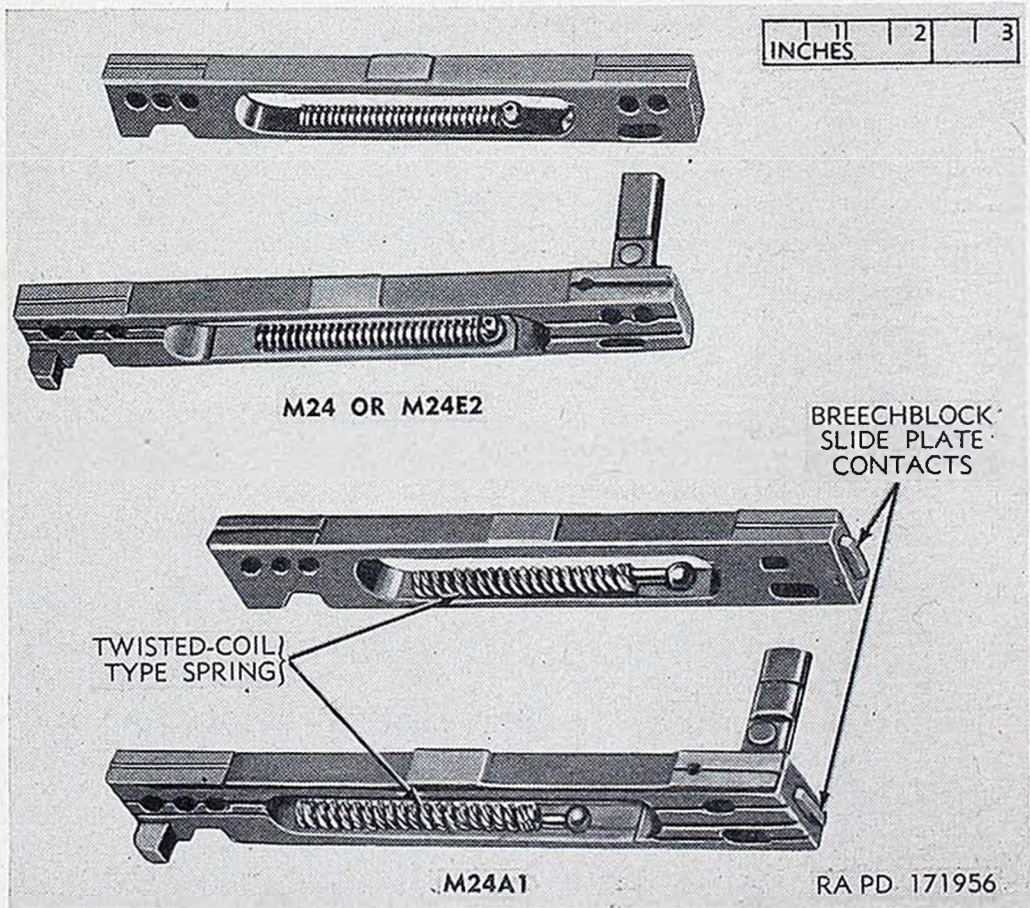

Figure 6. Comparison of breechblock slides.

RESTRICTED—Security Information

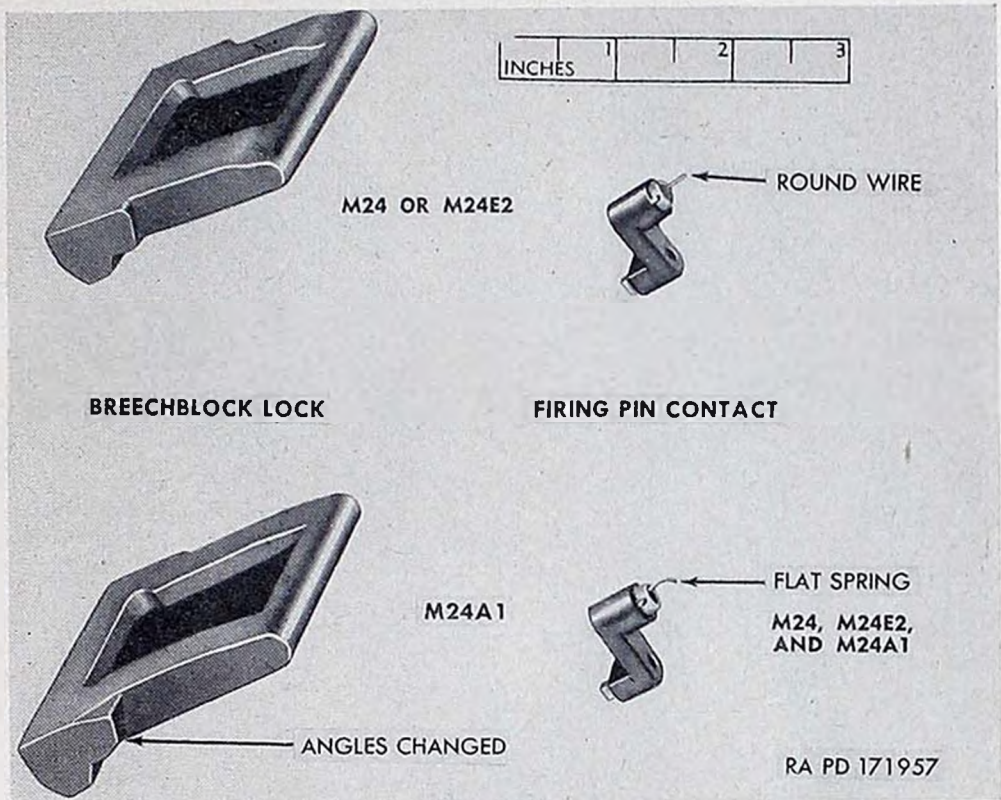
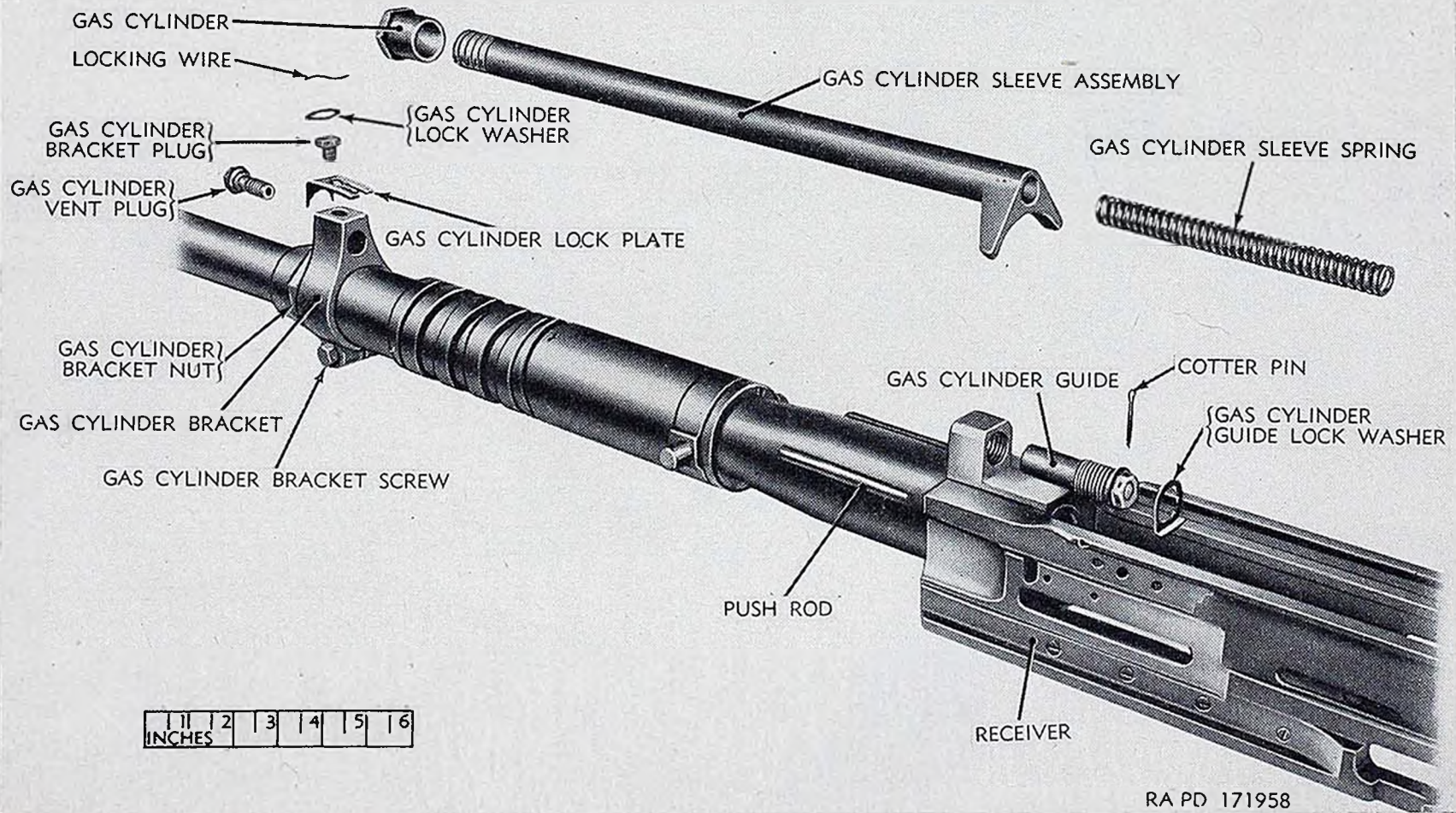

Figure 7. Comparison of breechblock locks and firing pin contacts.

- (e) The diameter of the breechblock slide spring guide and the inside diameter of the twisted-coil type guide spring have been reduced, as shown in figure 6.
- (2) *Gas cylinder group.*
- (a) The differences between the gas cylinder groups are illustrated in figures 8 and 9.
- (b) In the gun M24A1, the gas cylinder sleeve spring is of the twisted-coil type, the gas cylinder bracket, which is of one-piece design with an integral metering device, is retained on the tube by a gas cylinder bracket key, screw, and screw nut and the gas cylinder guide is retained by a spring pin (fig. 9).
- Note.* Some early production guns M24A1 used the old-type bracket nut, which required a special lock washer to secure it in position.
- (3) *Driving spring group.*
- (a) The differences between the driving spring groups are illustrated in figures 10 and 11.
- (b) In the gun M24A1, a short and a long driving spring are used and a recess has been counterbored in the front of the head of the guide plunger to provide additional space for the driving spring (fig. 11).



RA PD 171958

Figure 8. Gas cylinder group of guns M24 and M24E2.

RESTRICTED

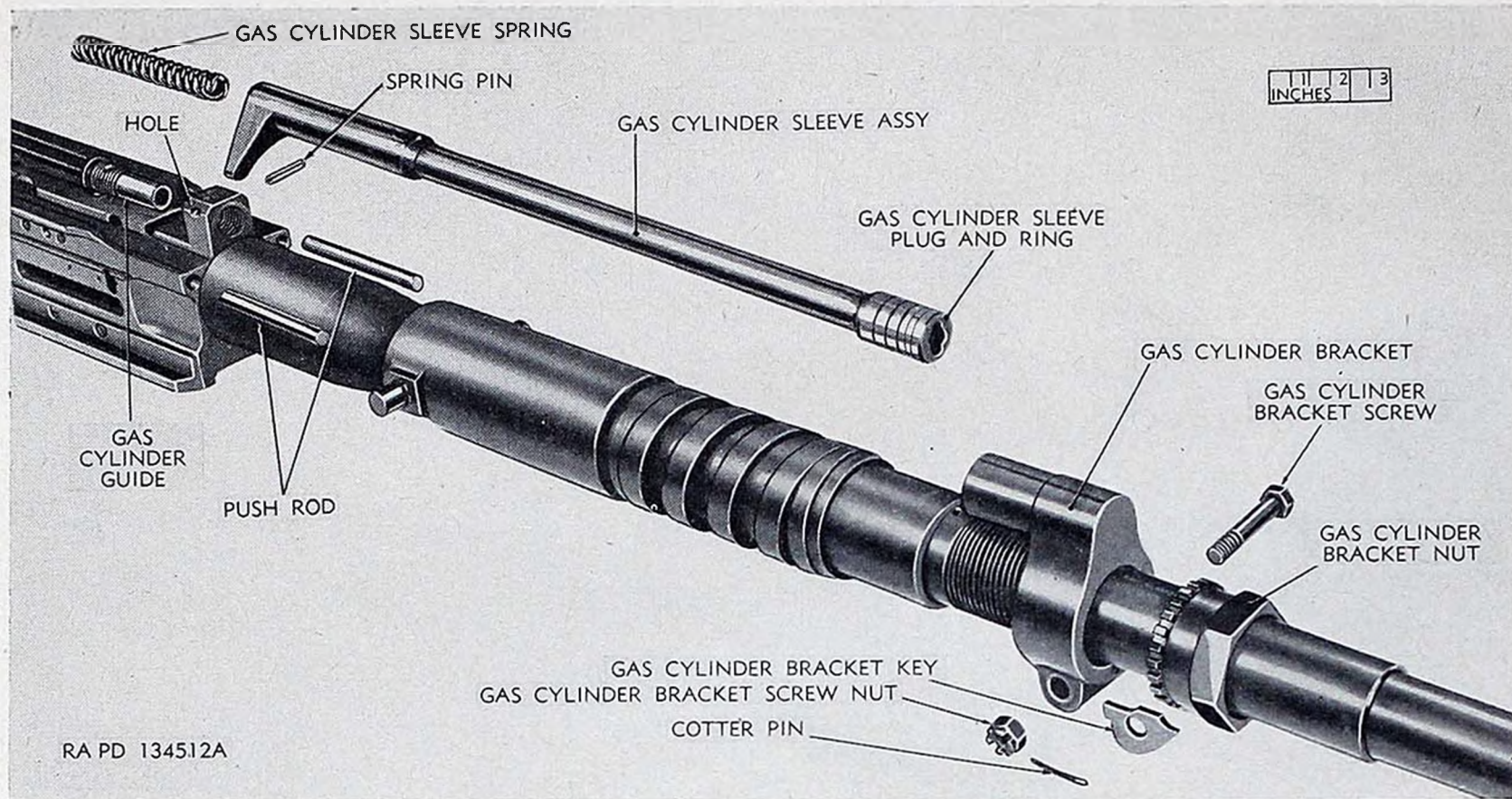

RESTRICTED—Security Information

Figure 9. Gas cylinder group of gun M24A1.

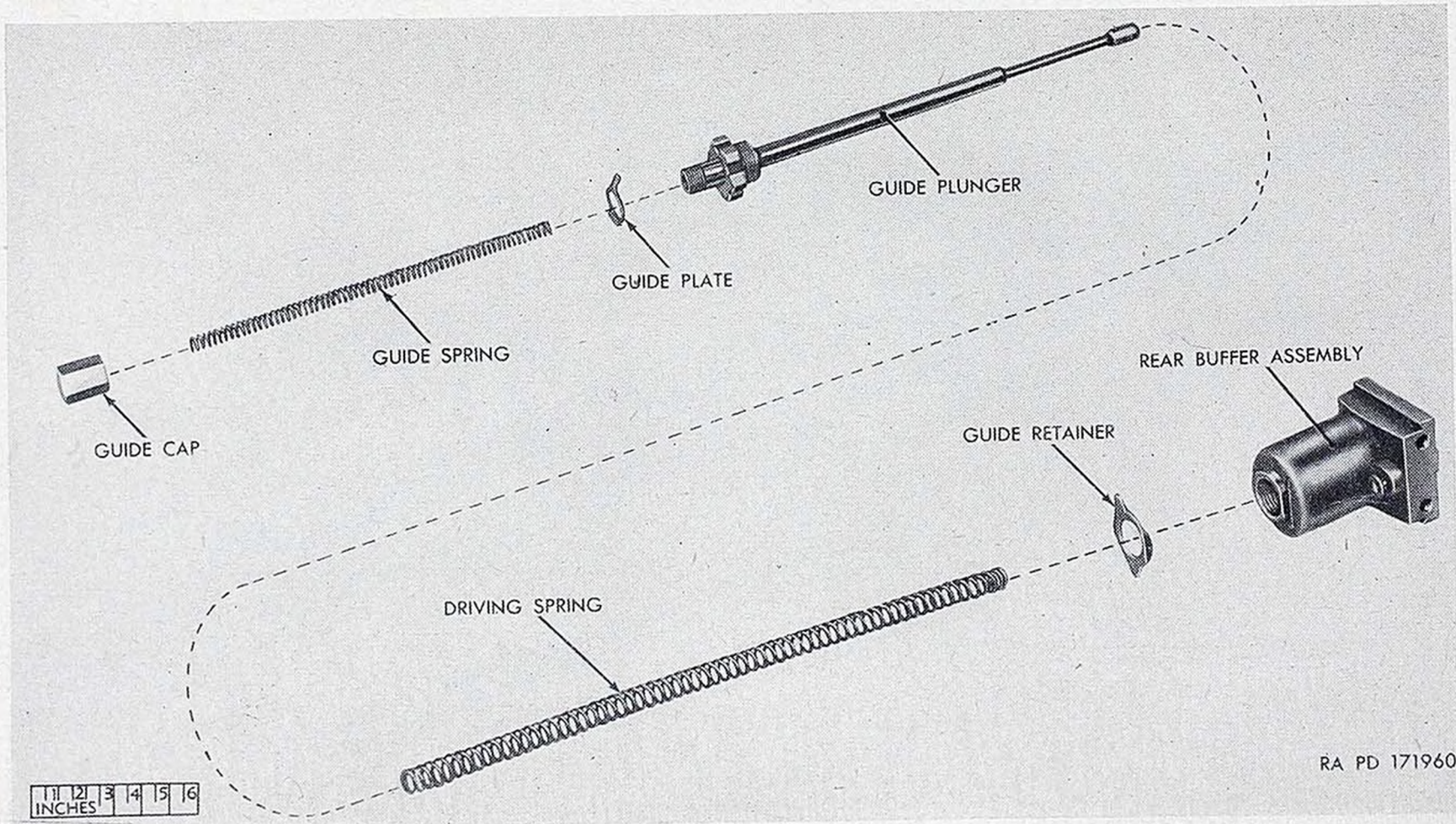

RA PD 171960

Figure 10. Driving spring group of guns M24 and M24E2.

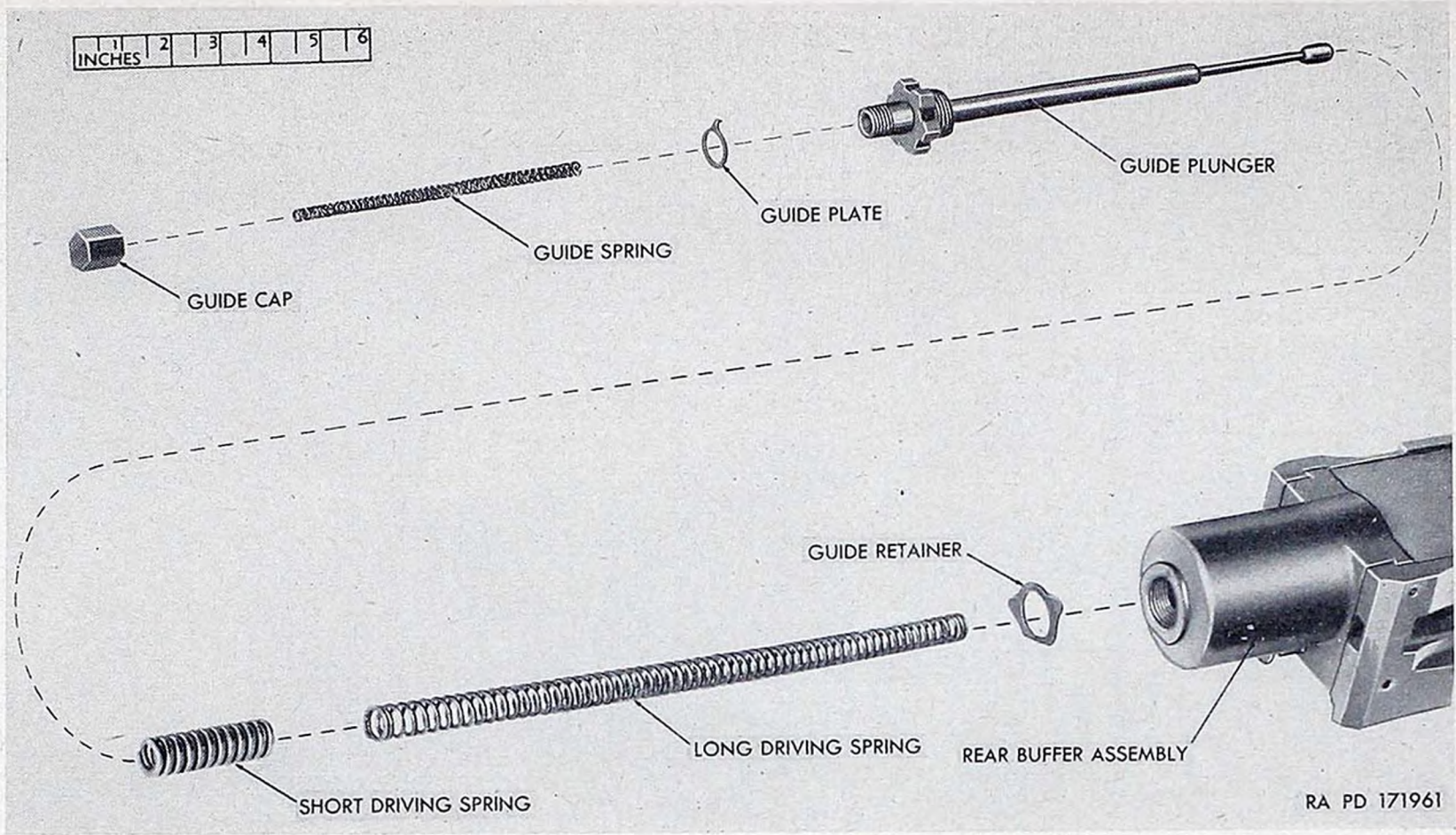

Figure 11. Driving spring group of gun M24A1.

RESTRICTED—Security Information

(4) *Barrel assembly.*

- (a) The design, material, and heat treatment of the barrel assembly have been modified in order to increase its life and utility. Comparison of receiver groups is illustrated in figure 12.
- (b) The gun tube has been modified by providing clearance cuts for the bolt retainers (fig. 13). A hole for contact switch (fig. 13) in the tube chamber has been provided. This switch is used in certain installations only, and the hole is covered with a lock plate (fig. 32) until utilized.
- (c) The breechblock locking key has an increased life due to a change in material and heat treatment.
- (d) The magazine slide anchor screw has a large cotter pin hole to insure more positive locking.
- (e) Instead of a long slot in the receiver for accommodating the two-wire breechblock contact (fig. 14), there is a short slot to house the new single wire breechblock contact (fig. 15).

c. *Feed Mechanisms.*

- (1) *M2E4.* This model differs from the AN-M2 in that it has provision for installing a heater cartridge to assure functioning at low temperatures and is equipped with longer link stripper cams for more positive stripping.
- (2) *M2E5.* This model differs from the M2E4 by the addition of a link aliner cam in the chute adapter to aline the links of the incoming rounds.

Note. Although guns and feed mechanisms may carry the same model designations, they may differ in component parts.

5. Identification Information

a. Serial numbers of both the tube and the gun are required for reports and records concerning the gun.

b. The serial number of the gun is stamped on the rear of the receiver (fig. 16).

c. The serial number of the tube is stamped on the tube in front of the gas cylinder bracket (fig. 17).

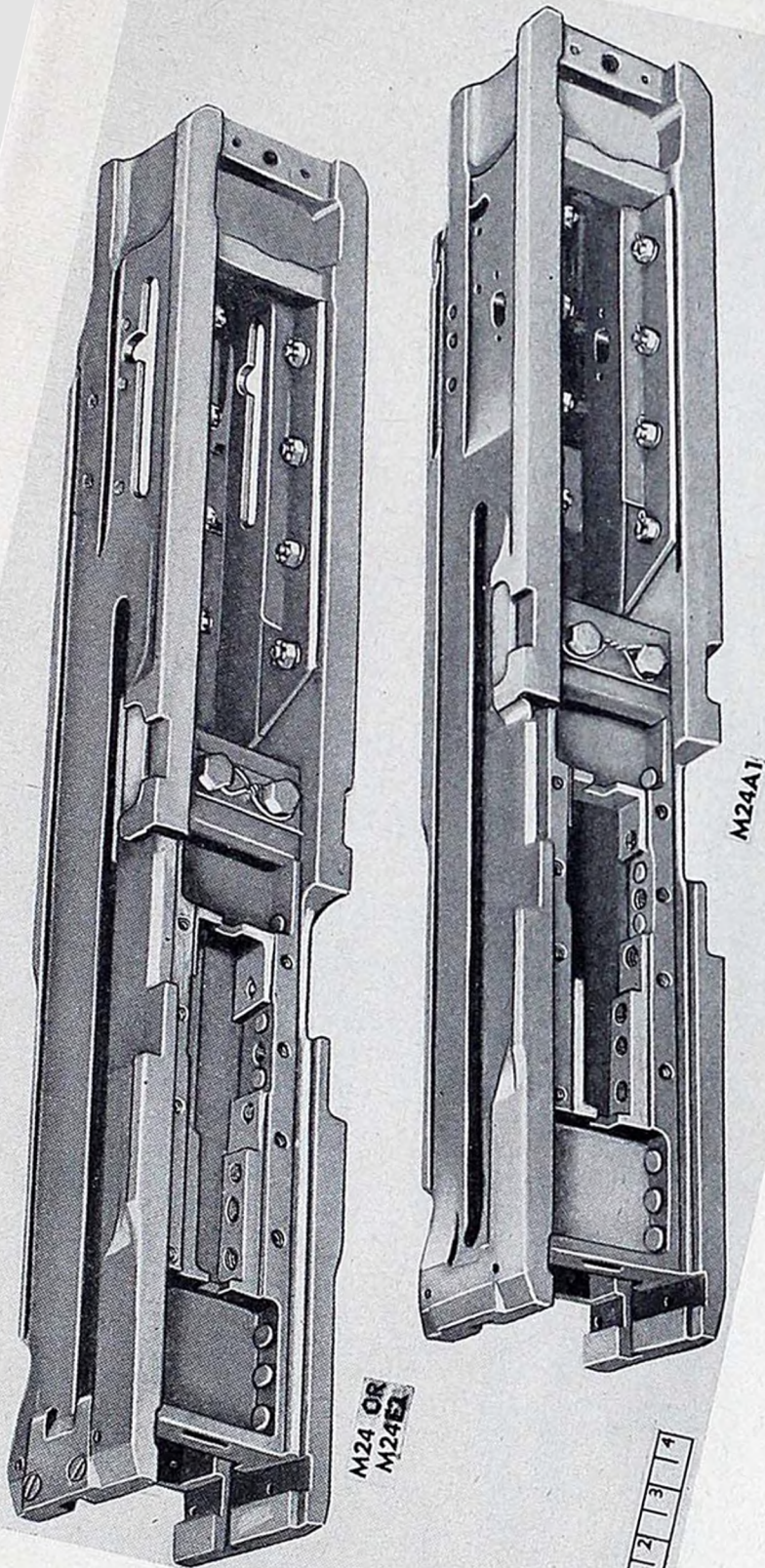

RA PD 171962

Figure 12. Comparison of receiver groups.

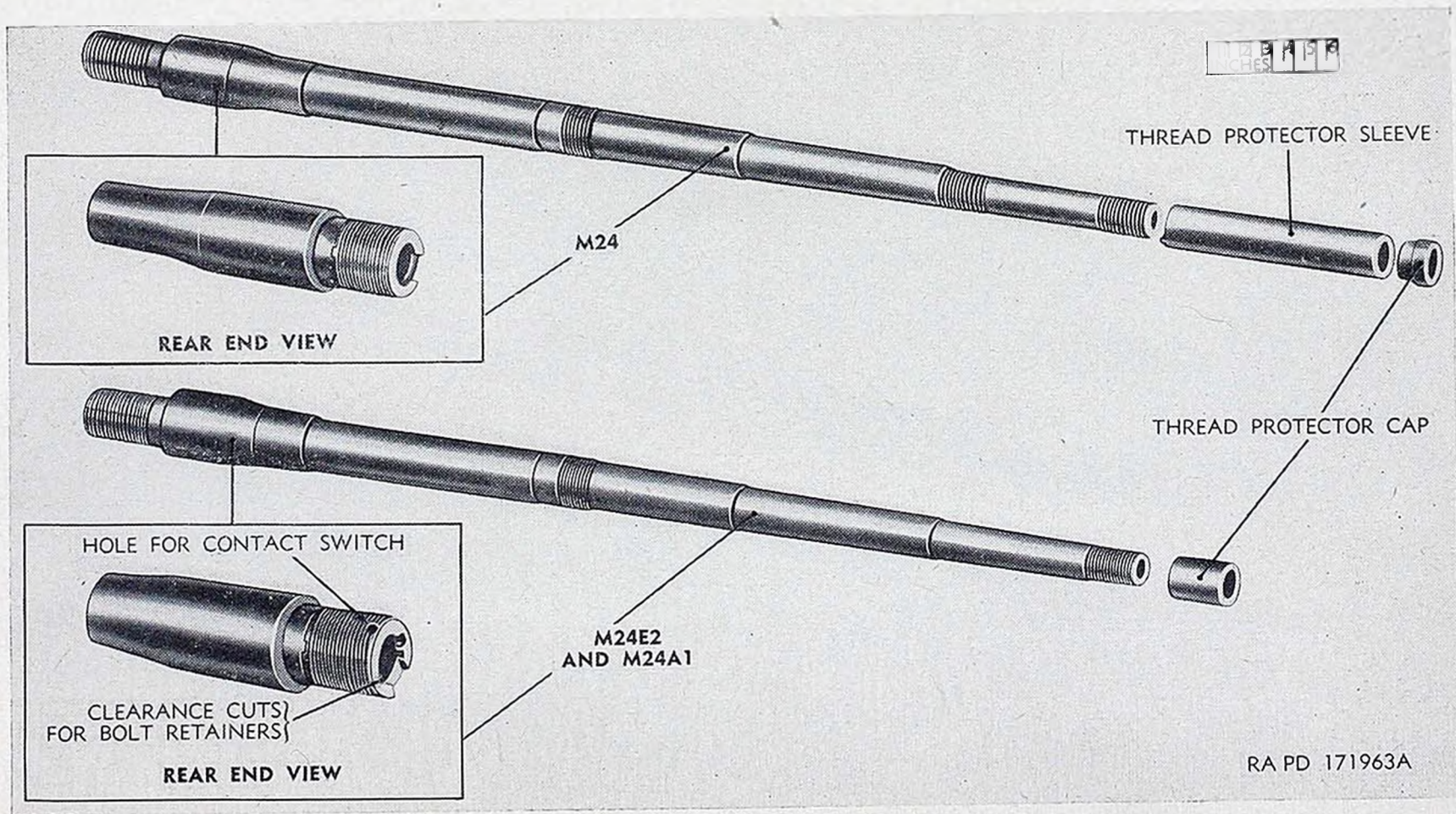

Figure 13. Comparison of tube groups for guns M24, M24E2, and M24A1.

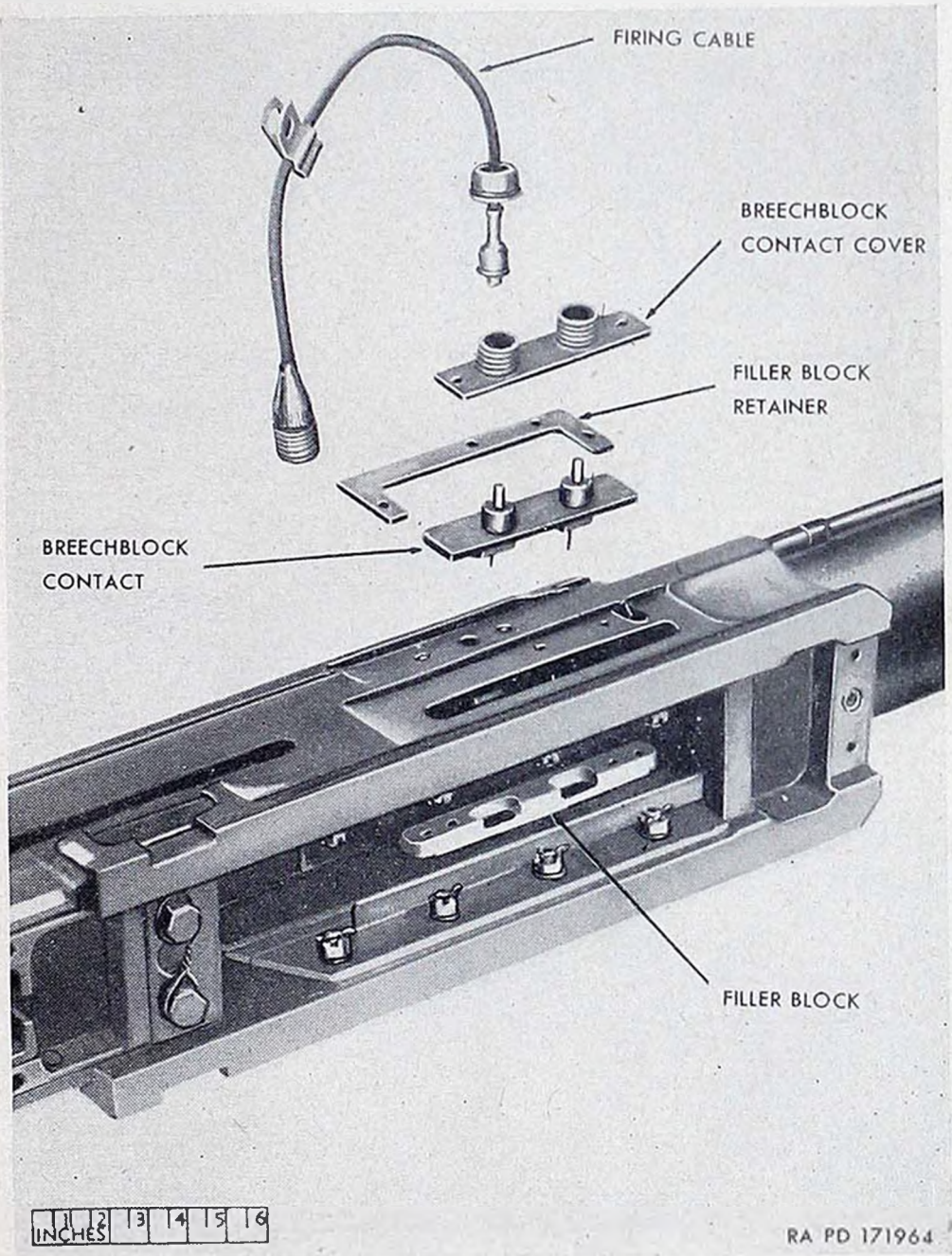

Figure 14. Electrical gun firing contact assembly for M24, M24E2, and early M24A1 guns.

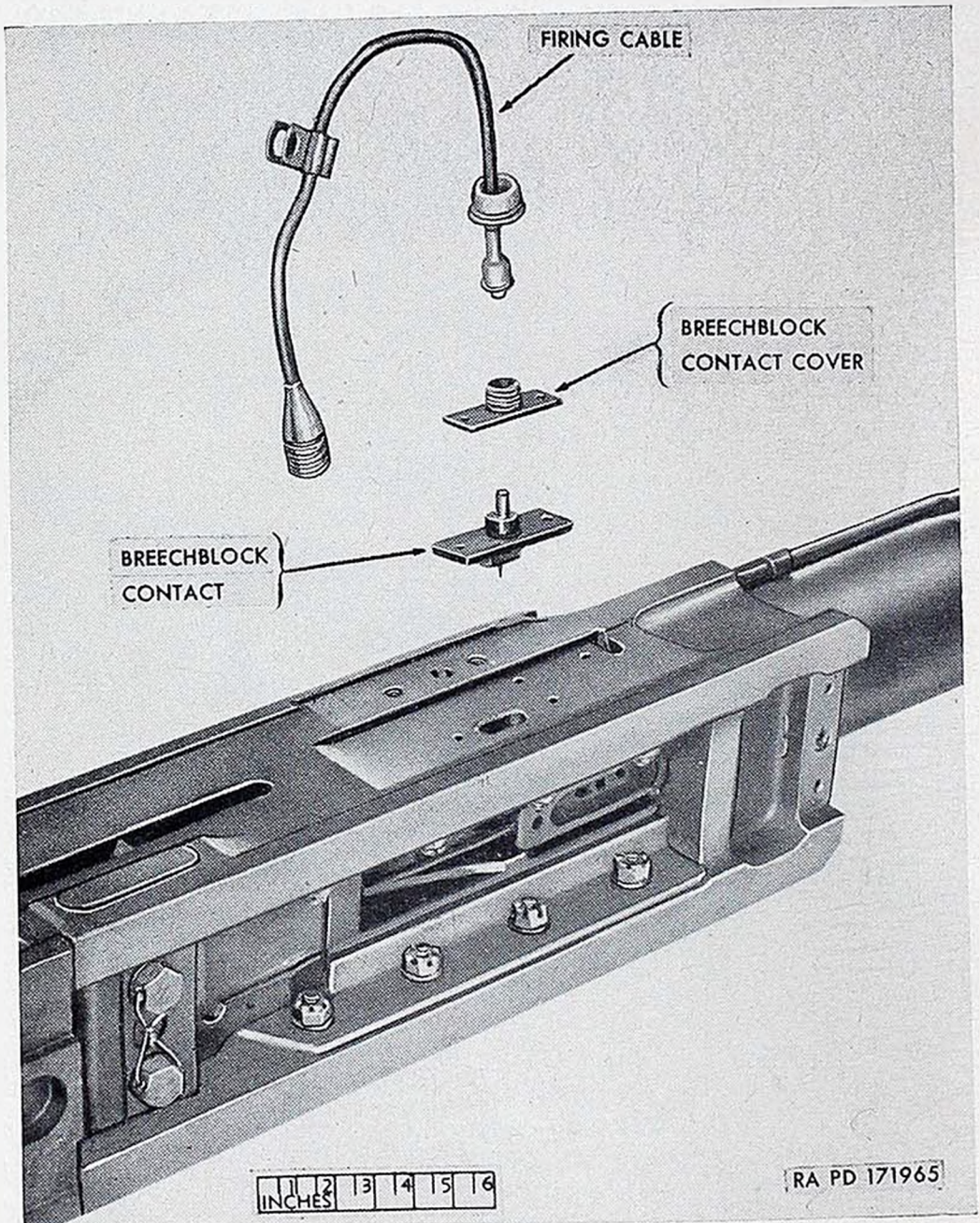

Figure 15. Electrical gun firing contact group for M24A1 gun.

RESTRICTED—Security Information

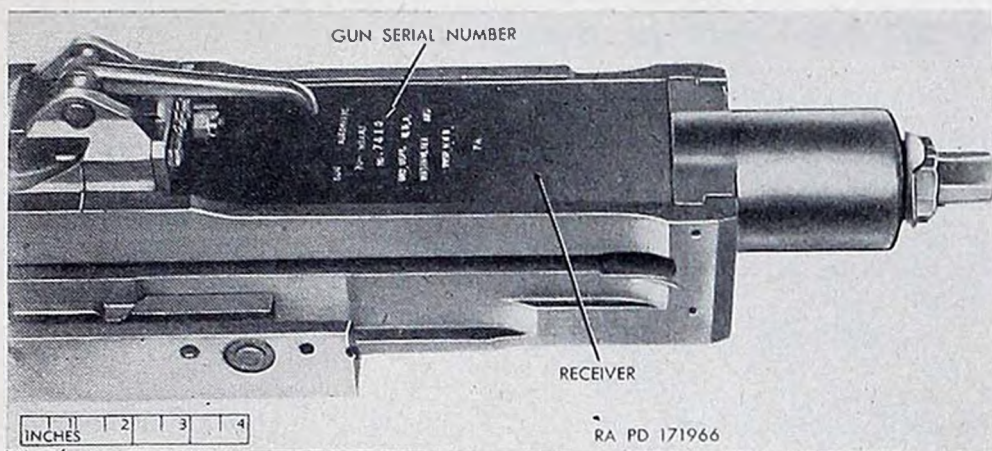

Figure 16. Location of serial number of gun.

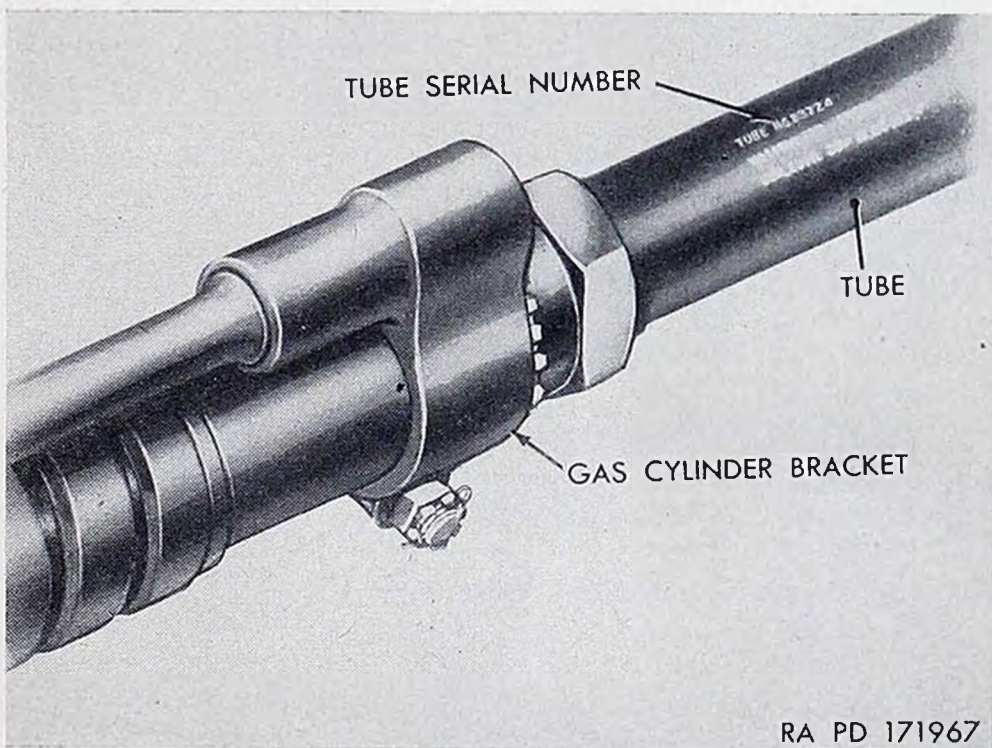

Figure 17. Location of serial number on gun tube.

RESTRICTED—Security Information

6. Tabulated Data for Guns

Data pertaining to guns are as follows:

Weight of gun, including cradle (aprx)-----	100 lb		
Weight of cradle assembly (aprx)-----	9 lb		
Overall length of gun-----	77.7 in		
Weight of tube-----	26.2 lb		
Length of tube-----	52.5 in		
Muzzle velocity-----	AP-T HEI TP Incendiary	} 2,730 fps	
Rate of fire-----	750 to 800 rds per min		
Rifling:			
Number of grooves-----	9		
Twist, uniform right-hand slope-----	7 deg		
Length-----	48.06 in		
Travel of projectile in tube-----	48.06 in		

7. Tabulated Data for Equipment

a. Feed Mechanisms.

Weight (aprx)-----	13 lb (AN-M2) 14 lb (M2E4 and M2E5)
Overall length-----	10.2 in (AN-M2) 11.3 in (M2E4 and M2E5)
Maximum extension:	
Above center line of gun (LH and RH feed)-----	5.5 in
To right of center line of gun (RH feed)-----	3.12 in
To left of center line of gun (RH feed)-----	3.5 in
To left of center line of gun (LH feed)-----	3.12 in
To right of center line of gun (LH feed)-----	3.5 in

b. Chargers.

(1) 20-mm pneumatic charger M4.

Weight-----	2.5 lb
Length-----	23.2 in
Operating pressure-----	800 lb

(2) 20-mm manual charger M6.

Weight-----	3 lb
Length-----	19.2 in

CHAPTER 2

OPERATING INSTRUCTIONS

Note. Aircraft gun controls are the responsibility of the Air Force and are covered in Air Force technical orders.

Section I. SERVICE UPON RECEIPT OF MATERIEL

8. General

a. When new or used materiel is first received by the using organization, it is necessary for the organizational mechanics to determine whether the materiel is complete and has been properly prepared for service by the supplying organization. Reference to paragraphs 61 through 89 will provide information on components of the various major groups of the guns and equipment.

b. A record should be made of any missing parts and of any malfunctions. Any such conditions should be corrected as quickly as possible.

c. Attention should be given to small and minor parts as these are more likely to become lost and, when lost, may seriously affect the proper functioning of the materiel.

d. The materiel should be cleaned and prepared for service in accordance with instructions given in paragraph 9 or 10.

e. Initiate AF Form 185 at this point if not included with gun.

9. New Materiel

a. New guns received from storage are packed in a heat-sealed, water-vaporproof barrier bag. Guns previously were packed in water-vaporproof bags and cotton stockinets (known as Saran packing).

b. Guns packed by the use of these methods are completely coated with a light film of preservative lubricating oil (special) and are serviced as follows:

- (1) Remove gun and its packing from the wooden container.
- (2) Remove water-vaporproof bag or Saran packing (stockinet and water-vaporproof bags).
- (3) The gun is now ready for use; however, to insure that no parts are corroded, missing, or incorrectly assembled, proceed as follows:

(*a*) Disassemble the gun to the extent outlined in paragraph 11.

RESTRICTED—Security Information

- (b) Thoroughly clean the gun by wiping the film of oil from all parts. Check the front face of the bolt and other surfaces exposed to powder fouling or corrosion. Check parts for cracks and other visual defects.

Note. It will be noticed that some of the internal moving parts will show what appears to be slight wear. Each new gun is test fired a minimum of 120 rounds, which has the effect of wearing away portions of the protective finish applied to component parts. This is a normal condition.

- (c) Clean bore (par. 81c).
- (d) Check gun to make certain that all technical orders have been applied. Current technical orders are indexed numerically and alphabetically in TO No. 00-1-1 and TO 00-1-2, respectively.
- (e) Lubricate as outlined in paragraph 38 and assemble gun.
- (f) Check lock clearance (par. 15 or 16).
- (g) Check electrical firing circuit (par. 17).
- (h) Where the materiel is the responsibility of the Air Force, check Air Force technical orders for any special equipment used with this materiel. Different types of aircraft use various types of equipment.
- (i) Check spare parts and equipment with Department of the Army Supply Catalog ORD 7 SNL A-73.
- (j) Inspect special tools and equipment listed in paragraphs 34 through 37.

10. Used Materiel

Used materiel requires the same inspection and service as prescribed for new materiel (par. 9) and the following checks in addition:

- a. Check all parts of the materiel for signs of wear, damage, missing parts, or corrosion and correct any deficiencies.
- b. Check AF Form 185 for number of rounds fired. Guns that have been fired for more than 5,000 rounds should be inspected by field maintenance personnel.

11. Disassembly of Materiel Prior to Cleaning

- a. Remove and disassemble electrical gun firing contact parts (par. 81b).
- b. Remove driving spring guide and parts (par. 66a).
- c. Remove rear buffer assembly (par. 66c).
- d. Remove and disassemble breechblock assembly (pars. 70 and 71).
- e. Remove gas cylinder sleeve group assembly (par. 76).

12. Cleaning Guns and Equipment Coated With Rust-Preventive Compound

a. All guns and components of guns received from storage that are coated with rust-preventive compound will be thoroughly cleaned with waste, wiping cloths, or a brush saturated with dry-cleaning solvent or volatile mineral spirits or with a solution of four parts of dry-cleaning solvent or volatile mineral spirits and one part of grease-cleaning compound. Vapor degreasing or steam jet, if available, may be used to facilitate removal of the compound. After complete removal of the compound, lubricate as outlined in paragraph 43.

Caution: Immersion of the rear buffer assembly, recoil housing assembly, 20-mm pneumatic charger M4, and the 20-mm feed mechanisms in cleaning solution will result in damage to these assemblies.

b. Component parts of each gun will be cleaned separately. Although like parts are interchangeable, the parts originally assembled to each gun work best together.

Section II. OPERATION UNDER USUAL CONDITIONS

13. General

Information in this section is concerned with the steps necessary to operate the guns under usual conditions. Usual conditions are considered to be a temperate climate with moderate temperature and humidity. In the case of this aircraft materiel, usual operating conditions are the atmospheric conditions ordinarily encountered while the aircraft is flying at low altitudes in a temperate zone. Preventive maintenance of the gun, as described in this manual, refers to maintenance under usual conditions. When flying at high altitude is anticipated, refer to paragraphs 29 and 30.

14. Installation of Gun in Aircraft

Gun installation in aircraft is the responsibility of the Air Force. Instructions for mounting the materiel in aircraft are covered in Air Force technical orders.

15. Checking Lock Clearance of 20-MM Automatic Guns M24 and M24E2

a. Remove the magazine slide anchor (par. 21c(9)) and the driving spring guide and spring (par. 66a).

b. Move the magazine slide forward until the face of the breechblock is exposed. Lock the breechblock in the forward position, with the breechblock lock seated against the breechblock locking key.

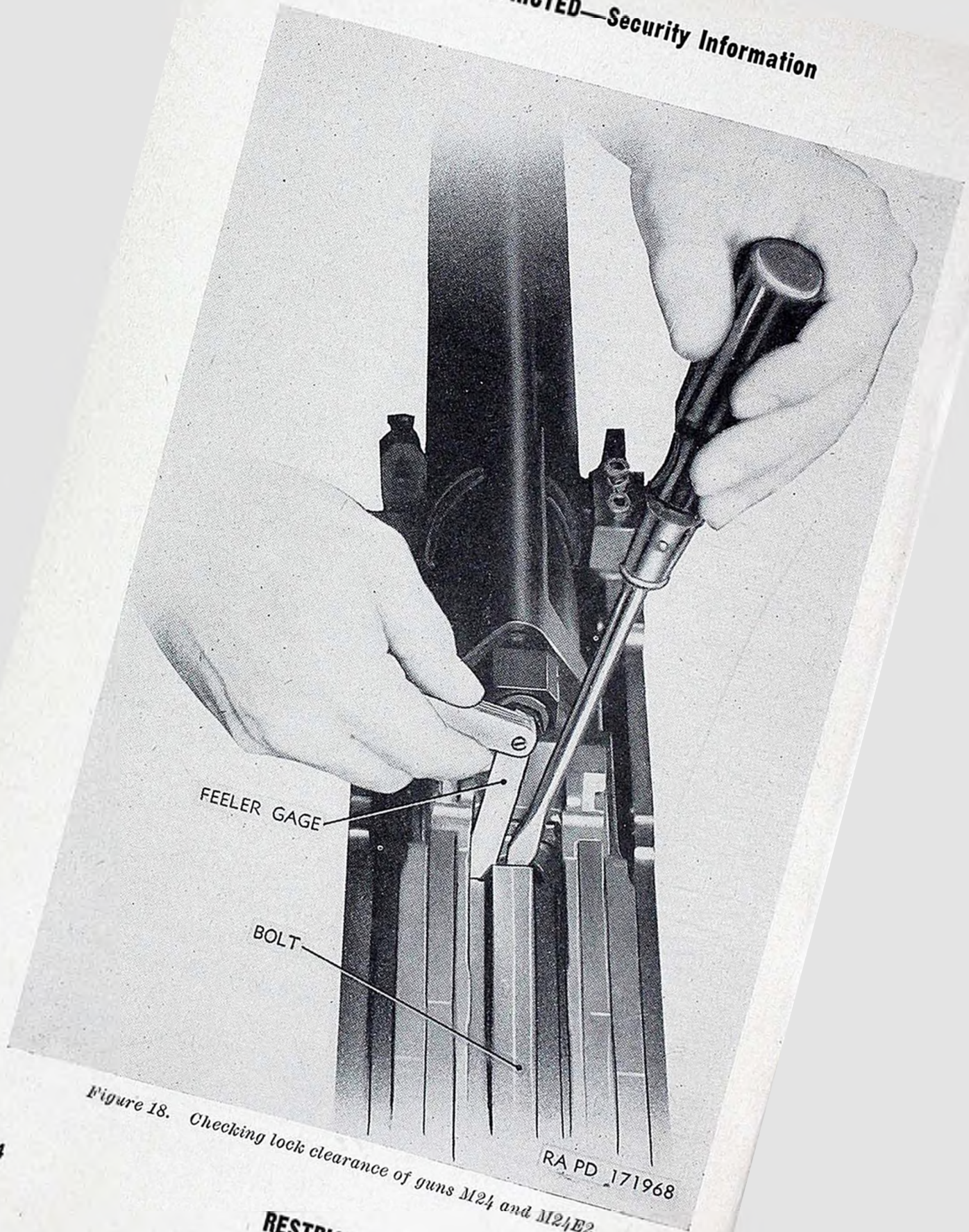

Figure 18. Checking lock clearance of guns M24 and M24E2.

RA PD 171968

RESTRICTED—Security Information

c. Force the breechblock rearward by inserting a large screwdriver between the rear face of the tube and the shallow recess in the face of the bolt assembly (fig. 18).

Caution: A smooth-blade tool or screw driver should be used and care exercised to avoid marring surfaces of tube or breechblock.

d. Use a feeler gage (fig. 18) to accurately measure the distance between the right-hand and left-hand bottom areas of the breechblock and the receiver surface. Do not measure the distance between the breechblock and the rear face of the tube. The average of the right-hand and the left-hand measurements should be 0.015 inch or less. If the average of the two is greater, notify field maintenance personnel. The feeler gage should be inserted with firm rather than light pressure in order to obtain a true reading. However, the pressure applied to the feeler leaves should not produce distortion or scoring of the leaves.

16. Checking Lock Clearance of 20-MM Automatic Gun M24A1

The addition of the two bolt retainers (fig. 5) on the side of the bolt of the gun M24A1 have made it impossible to measure head space in the same manner as on the gun M24. Detailed instructions for checking head space are given in *a* through *d* below.

a. Remove the magazine slide anchor (par. 21*c*(9)) and the driving spring guide and springs (par. 66*a*).

b. Move the magazine slide forward until the face of the breechblock is exposed. Lock the breechblock in the forward position, with the breechblock lock seated against the breechblock locking key.

c. Force the breechblock rearward by inserting a large screw driver between the rear face of the tube and the shallow recess in the face of the bolt assembly (fig. 18).

Caution: A smooth-blade tool or screw driver should be used and care exercised to avoid marring surfaces of tube or breechblock.

d. Insert a feeler gage through the expended case opening (fig. 76) in the bottom of the cradle and accurately measure the distance between the right-hand and left-hand bottom areas of the breechblock and receiver surface. Do not measure the distance between the breechblock and the rear face of the tube.

e. The average of the right-hand and left-hand measurements should be 0.015 inch or less. If the average of the two is greater, notify field maintenance personnel.

17. Checking the Electrical Firing Circuit

a. Gun Circuit.

- (1) Before placing the bolt in the receiver, check the resistance between the firing pin point and the firing pin contact.
 - (a) With the firing pin completely forward, the ohmmeter should read zero or slightly above.
 - (b) With the firing pin rearward, check the resistance between the firing pin contact and a well-polished spot on the bolt. This resistance should be high, several megohms or more. The firing pin point should be retracted by pushing it rearward with an insulated tool, otherwise this check will be misleading. The firing pin makes a short circuit when it is fully forward and in contact with the walls of the firing pin hole.
 - (c) If the results differ from those in (b) above, examine the firing pin contact for damage or misalignment of the wire contact to the firing pin and for short circuits produced by firing pin spring, firing pin, firing pin guide, metal slivers from cartridge cases, etc.
 - (d) If a short circuit can be induced between the partially withdrawn firing pin and the firing pin hole, check firing pin and guide for straightness or tolerances.
- (2) When the checks above have been made satisfactorily, place the bolt in locked position.
 - (a) Check for continuity at the connector end of the receiver contact assembly. The ohmmeter should indicate a short circuit.
 - (b) Partially withdraw the firing pin. The circuit should be broken.
 - (c) If the results differ from those in (a) above, examine the cable and the electrical gun firing group for damage or misalignment. Check the rubber-covered cable for brittleness, cracks in the insulation, etc., especially after it has been subjected to extreme temperatures.

Note. If a misfire occurs during firing, it will be found easier to check in the reverse order; that is, first with the bolt in the locked position and then with the bolt outside the receiver.

b. Firing Circuit.

- (1) *Free-firing guns.* In free-firing (unsynchronized) guns, where the breechblock contact mounted in the receiver is always energized, the output of the circuit should be measured at the connector end of the firing cable or breechblock contact wire and ground, using a dc voltmeter.

RESTRICTED—Security Information

- (2) *Controlled guns.* For those circuits that control the rate of fire of two guns and synchronized one with the other, a different method must be used. Suggested methods of measuring the short pulses from an electric synchronizer are as follows:
- (a) *Lights.* Arrange three or more neon lights in such a manner that each tube requires approximately one-third the minimum firing voltage to light. With three lights in a series, if the output is 160 volts or greater, all lights will flash.
 - (b) *Special vacuum-tube or selenium-rectifier meter.* The pulse output passes through a diode vacuum tube or selenium rectifier arranged so that the output current flows in one direction but is prevented from flowing in the reverse direction when the pulse decays to zero. By successive pulses, a capacitor (condenser) placed beyond the tube or rectifier becomes charged with a voltage equivalent to the output minus the loss through the tube or rectifier. Upon proper calibration, the output can be read directly from a voltmeter connected across the circuit beyond the tube or rectifier.

18. Installation and Removal of Chargers M4 and M6

a. Manual Charger M6.

- (1) *Adjusting the charger for right-hand or left-hand charging* (fig. 19). Determine whether the charger is to be installed for left-hand or right-hand charging (par. 21a). If necessary, adjust for either right-hand or left-hand charging as follows:
 - (a) Unscrew the two cradle mounting bracket screws with a socket wrench, swing the cradle mounting bracket 180°, and install the bracket.
 - (b) When properly adjusted, the yoke of the cradle mounting bracket points downward when the driving lug is adjacent to the side of the gun on which the charger is to be installed.
- (2) *Mounting the charger.*
 - (a) Secure cradle mounting bracket to cradle by means of the cradle mounting bracket screw and locking wire (fig. 21).
 - (b) Attach charger clamp to rear end of cradle, using clamp pin, washer, and cotter pin (fig. 20). The washer should be installed on the inside of the cradle and inside the arm of the clamp yoke. The clamp yoke must be installed so that, as viewed from above, the angle surface in the crotch of the clamp yoke (fig. 21) can be seen.

RESTRICTED—Security Information

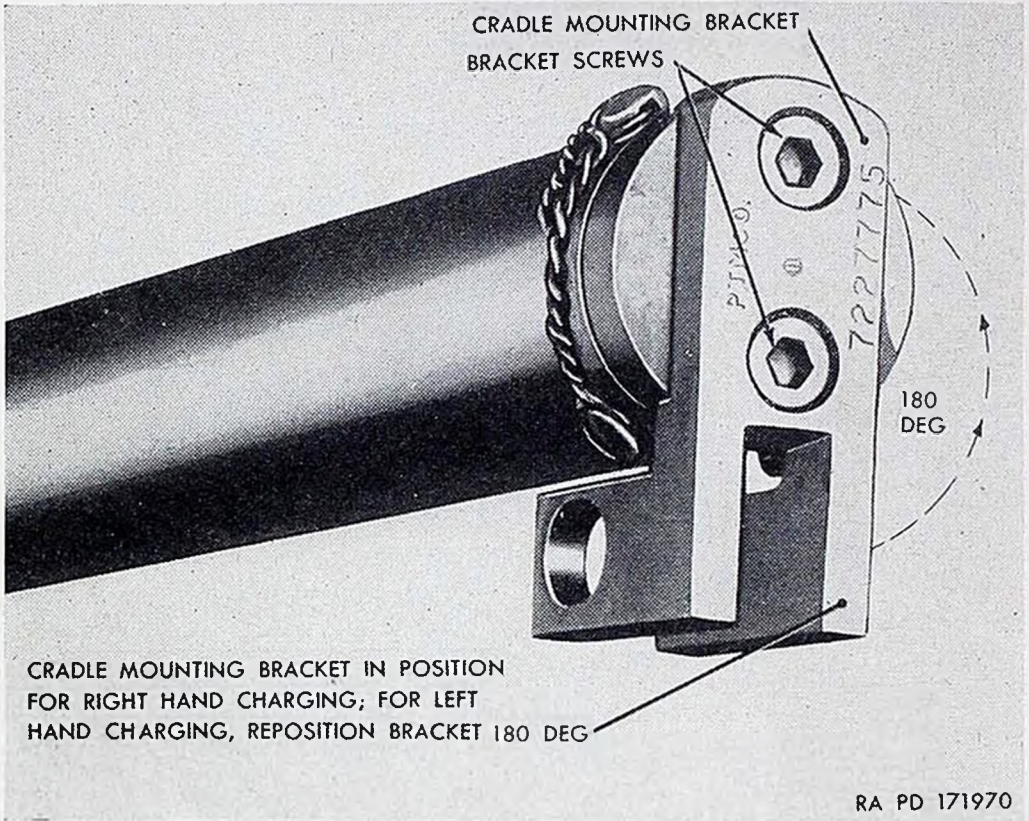

Figure 19. Adjusting 20-mm manual charger M6 for right-hand or left-hand charging.

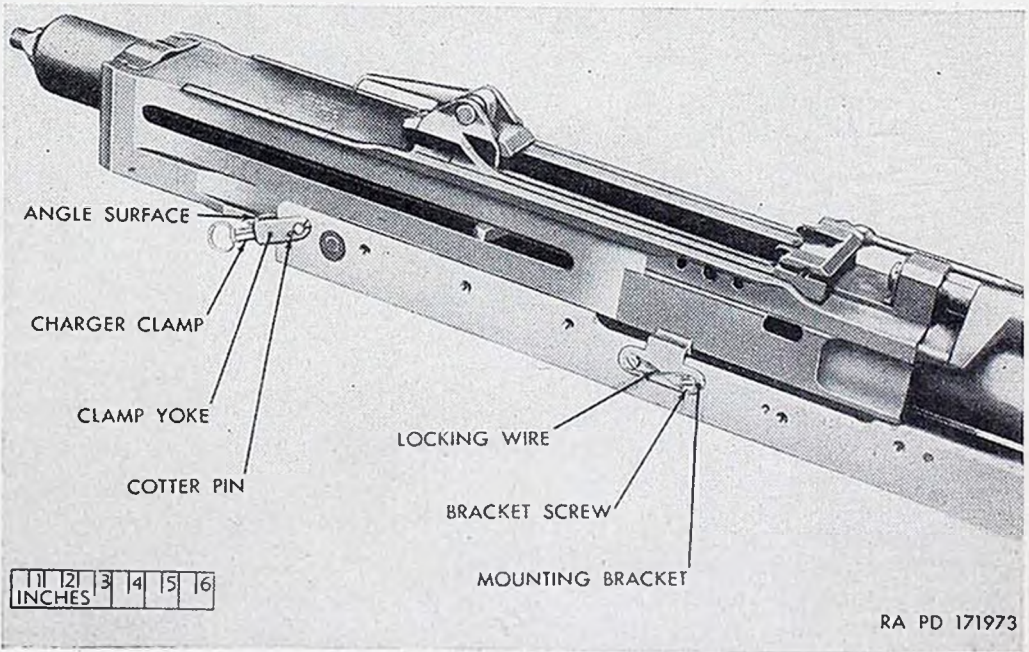

Figure 20. Installation of mounting bracket and charger clamp.

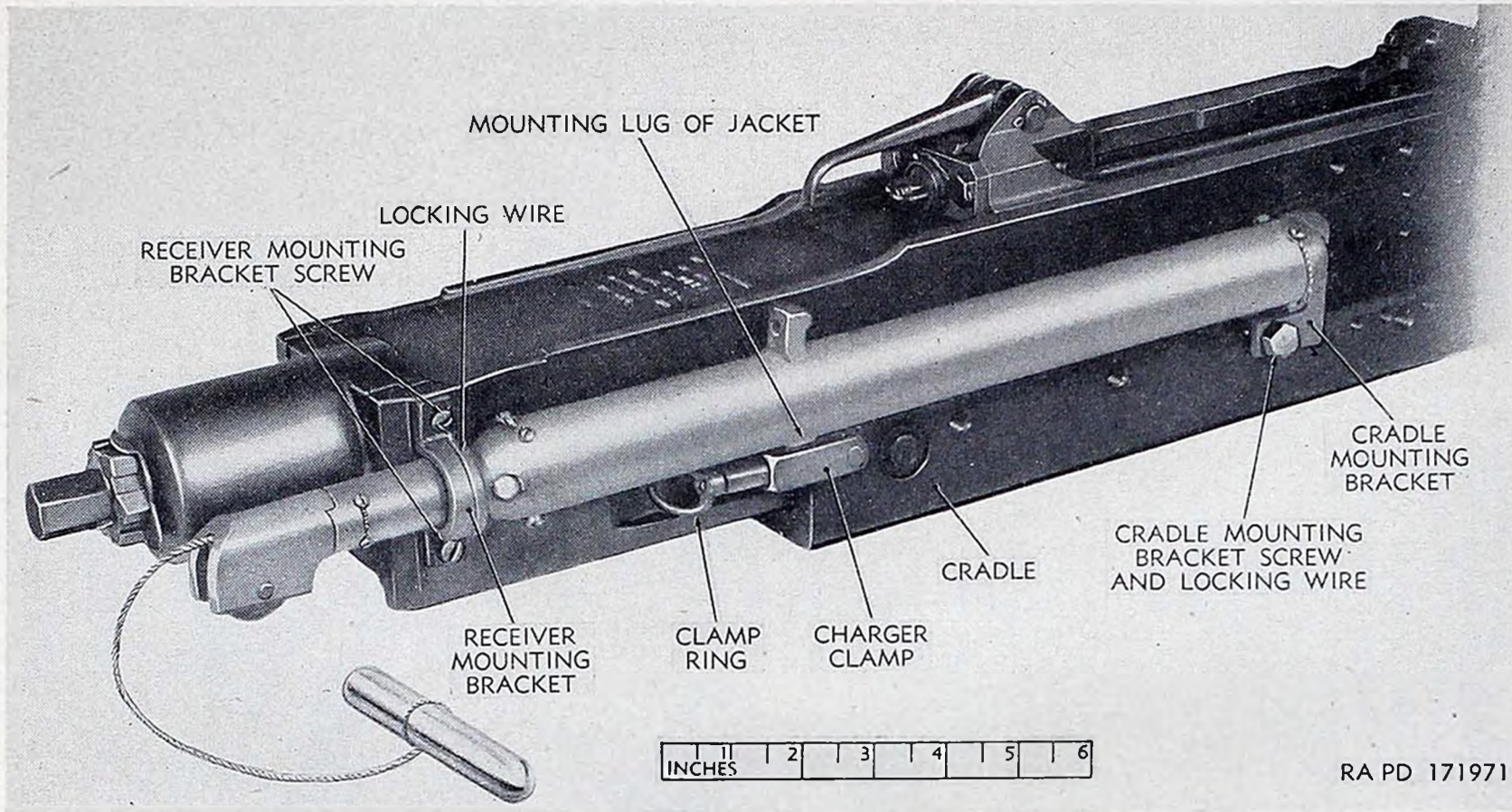

Figure 21. 20-mm manual charger M6 mounted on gun.

RESTRICTED—Security Information

- (c) Place charger on edge of cradle so that arms of cradle mounting bracket fits over side of cradle (fig. 21). Pull clamp ring rearward, swing charger clamp up into horizontal position, and release clamp ring so that clamp plunger fits into seat in lug of jacket.
 - (d) Secure rear of charger to gun by means of receiver mounting bracket, receiver mounting bracket screws, and locking wire (fig. 21).
- (3) *Dismounting the charger* (fig. 21).
- (a) Cut and remove locking wire, unscrew the two receiver mounting bracket screws, and remove the receiver mounting bracket.
 - (b) Cut and remove locking wire and unscrew cradle mounting bracket screw.
 - (c) Pull clamp ring rearward and swing charger clamp down so that clamp plunger is disengaged from mounting lug of jacket.
 - (d) Lift charger off cradle.
- b. *Pneumatic Charger M4.*
- (1) *Adjusting charger for right-hand or left-hand charging* (fig. 22). Determine whether the charger is to be installed for

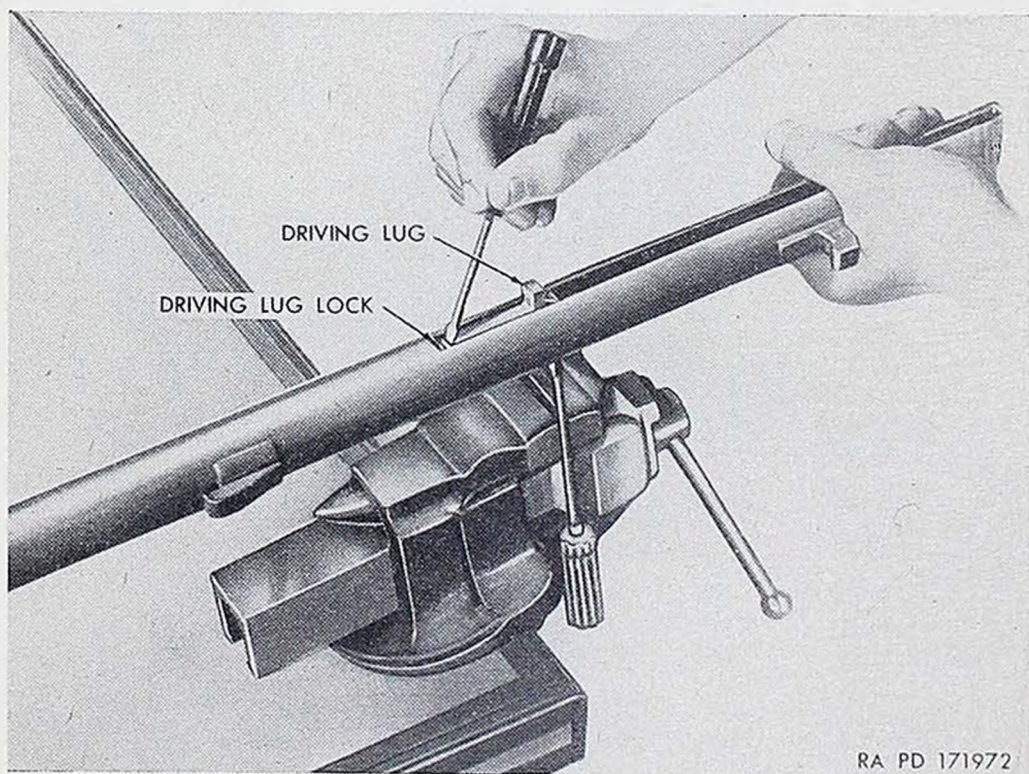

Figure 22. Removal of driving lug—20-mm pneumatic charger M4.

RESTRICTED—Security Information

left-hand or right-hand charging (par. 21a). If necessary, adjust for either left-hand or right-hand charging as follows:

- (a) Clamp a screw driver, having a blade width of no more than one-quarter inch, vertically in a vise. The blade should point upward and should extend about three-quarters of an inch above the jaws of the vise.
 - (b) Hold the charger in a horizontal position above the vise, with driving lug pointing upward and with rear end of charger against your body. The blade of the screw driver in the vise should engage the slot behind the flange of the piston body.
 - (c) Hold charger down firmly on screw driver and push charger forward with your body until the driving lug with the driving lug lock are exposed. Remove lock from the driving lug by prying notched end with a screw driver and pulling lug toward your body. Allow piston to return slowly to its normal position. Disengage charger from screw driver in vise.
 - (d) Apply a screw driver against knurled lines on piston body and turn piston one-half turn, so that recess for lug aligns with slot on opposite side of charger (because of the spring action, it is easier to turn the piston in the same direction in which the return spring is wound).
 - (e) Hold charger vertically, with conical cylinder nut downward, and shake gently so that driving lug lock will slide down piston.
 - (f) Hold charger in a horizontal position above vise, with rear end of charger against your body and with the blade of screw driver engaging slot behind flange of piston body.
 - (g) Place driving lug (notched end leading) in recess in piston body. Push charger forward with your body and position lug on piston body. With a screw driver, snap driving lug lock into notch on lug. Allow piston to return slowly to its normal position.
- (2) *Mounting the charger.*
- (a) Attach mounting bracket to side of cradle by means of two screws and secure screws with locking wire (fig. 20). The flange of the bracket should be on the outside of the cradle and the curved seat of the bracket should be directly over the edge of the cradle.
 - (b) Attach charger clamp to rear end of cradle, using clamp pin, washer, and cotter pin (fig. 20). The washer should be installed on the inside of the cradle and inside the arm

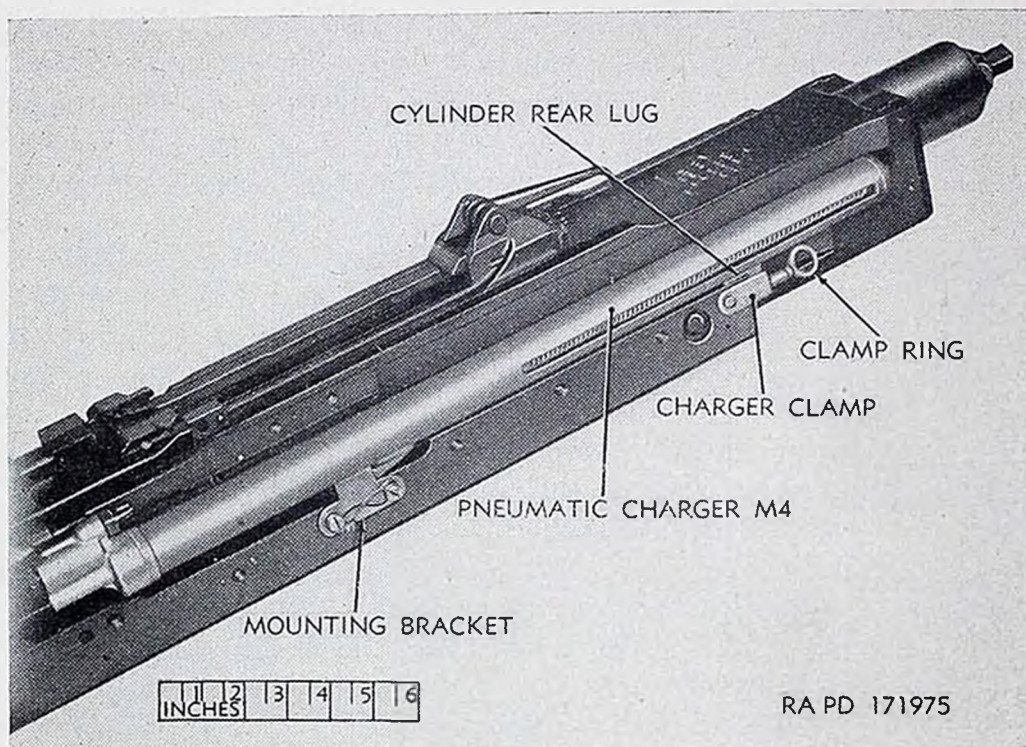

Figure 23. 20-mm pneumatic charger M4 mounted on gun.

of the clamp yoke (fig. 20). The yoke must be installed so that, as viewed from above, the angle surface in the crotch of the clamp yoke (fig. 20) can be seen.

- (c) Hold charger above edge of cradle, with driving lug toward side of gun and with head toward muzzle. Lower charger and push it forward so that cylinder front lug of charger enters under curved surface of mounting bracket (fig. 23).
- (d) Pull clamp ring rearward, swing the charger clamp up into horizontal position, and release clamp ring, allowing clamp plunger to enter seat in cylinder rear lug (fig. 23).
- (3) *Dismounting the charger* (fig. 23).
 - (a) Pull charger clamp ring rearward and swing it down so that the plunger is disengaged from cylinder rear lug.
 - (b) Lift rear end of charger slightly until cylinder rear lug is disengaged from cradle and pull charger to the rear and off cradle.

19. Hand Loading of Belts

a. General.

- (1) All links should be free of rust and dirt. Do not use any deformed links.
- (2) If links are not oiled, immerse them in preservative lubricating oil (special). Drain off excess oil before using links.

RESTRICTED—Security Information

Cartridge cases are coated with a wax film when manufactured. They should be kept clean and free of dust and dirt and shaded from direct rays of the sun.

b. *For Single-Loop Right-Hand Feed.*

- (1) Place links M10 (MSE1) on a belting board, open sides up, with single loop to the right and placed between the double loops.
- (2) Place cartridges in the loops and advance them forward. The distance from the base of the cartridge to the rear edge of the loop is $2\frac{9}{32} \pm \frac{1}{16}$ inch (fig. 24). The last double loop must contain a cartridge, while the first leading loop must be empty, as shown in figure 24.

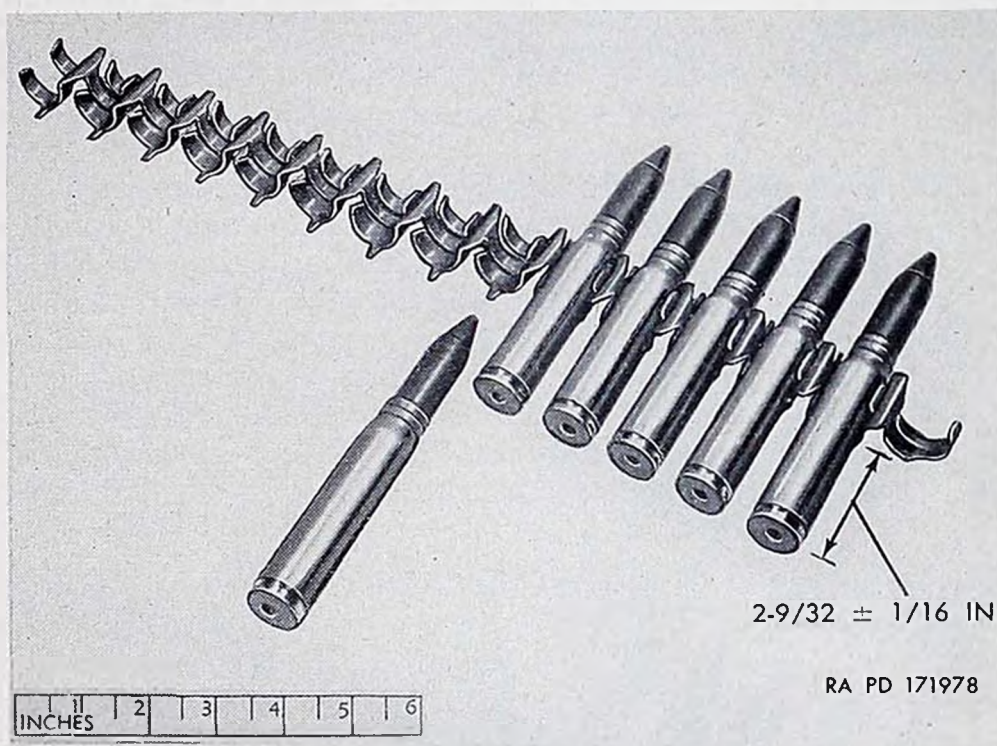

Figure 24. Hand-loading of links M10 (MSE1) for single-loop right-hand feed.

- (3) The completed belt, as shown in figure 25, must be flexible. Lift the left-hand end of the loop and draw it along the top of the belt to the right. If a link is deformed or improperly installed, it will cause a twist and the cartridges will not lap over evenly. All imperfect links must be replaced with other links and the examination repeated.
- (4) Test the belt for links that are too large by hanging it from one end and applying a twisting motion to the other until resistance is felt. The belt will come apart wherever there are oversize links.

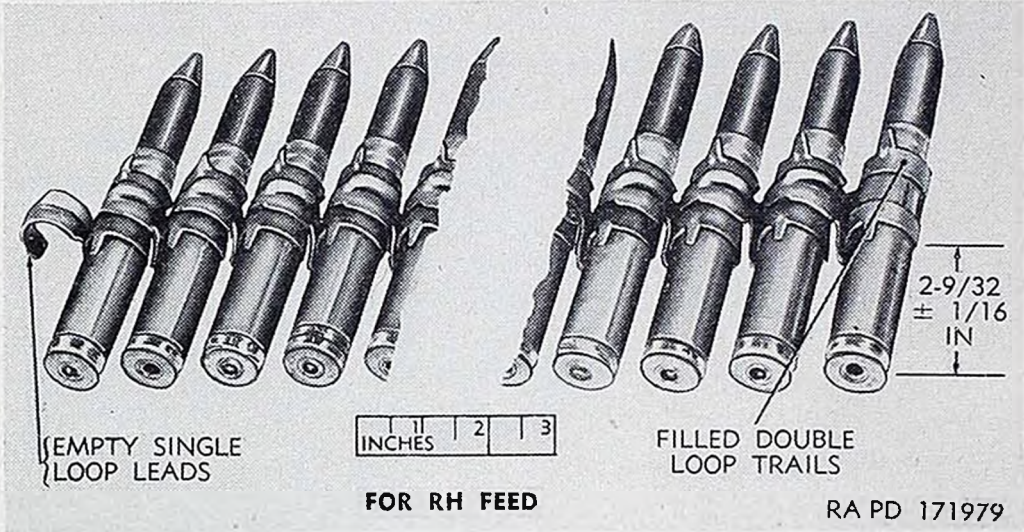

Figure 25. Loaded belt for single-loop right-hand feed.

- (5) Belts may be joined together by eliminating the cartridge from the last double loop of one belt and uniting it with the empty single loop of a second belt, by the insertion of a cartridge. When belts are joined together, prior to installation in the aircraft, it is necessary to repeat the tests given in (3) and (4) above.

c. For Single-Loop Left-Hand Feed. Proceed as in *b* above, but lay the single loops to the left on the belting board, as shown in figure 26. The completed belt is shown in figure 27.

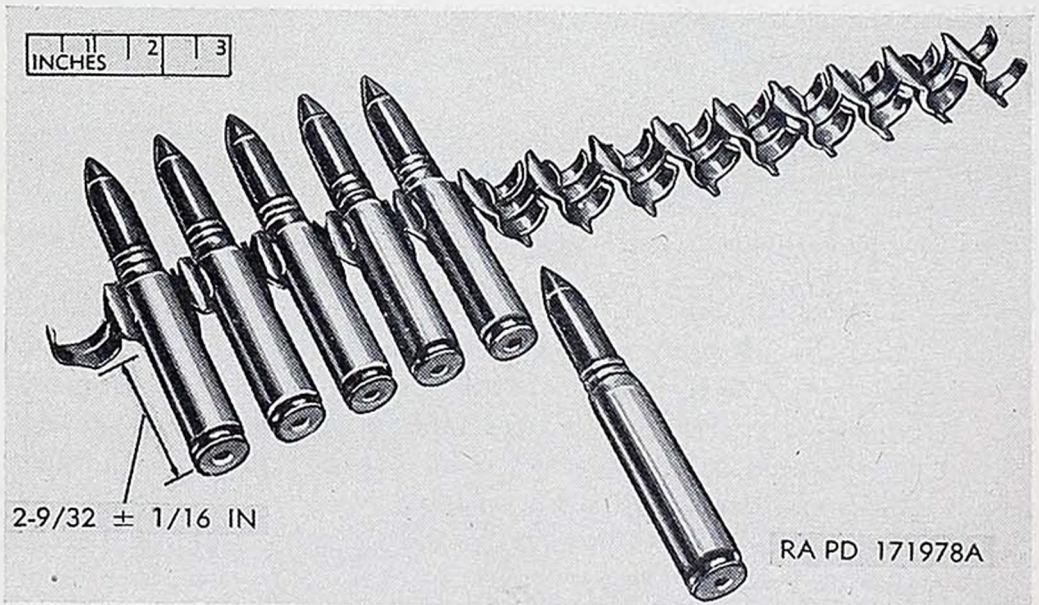

Figure 26. Hand-loading of links M10 (M8E1) for single-loop left-hand feed.

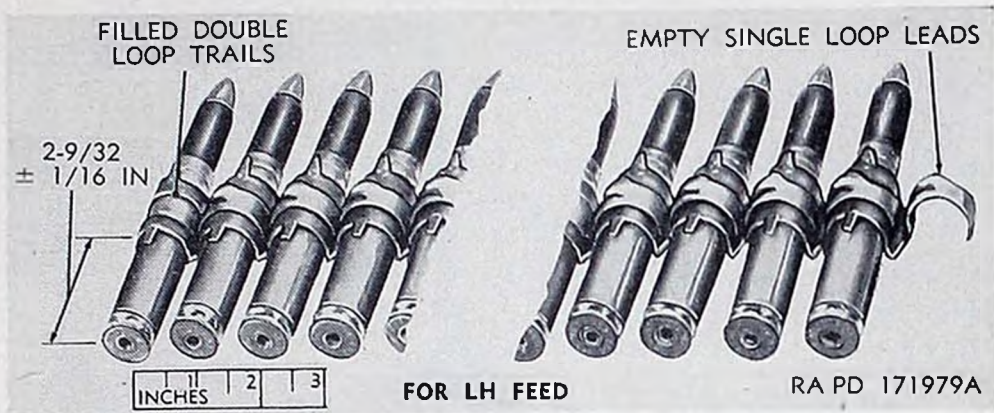

Figure 27. Loaded belt for single-loop left-hand feed.

d. For Double-Loop Left-Hand Feed. Proceed as in b above, but insert a filler piece in the single loop at the end of the belt, as shown in figure 28.

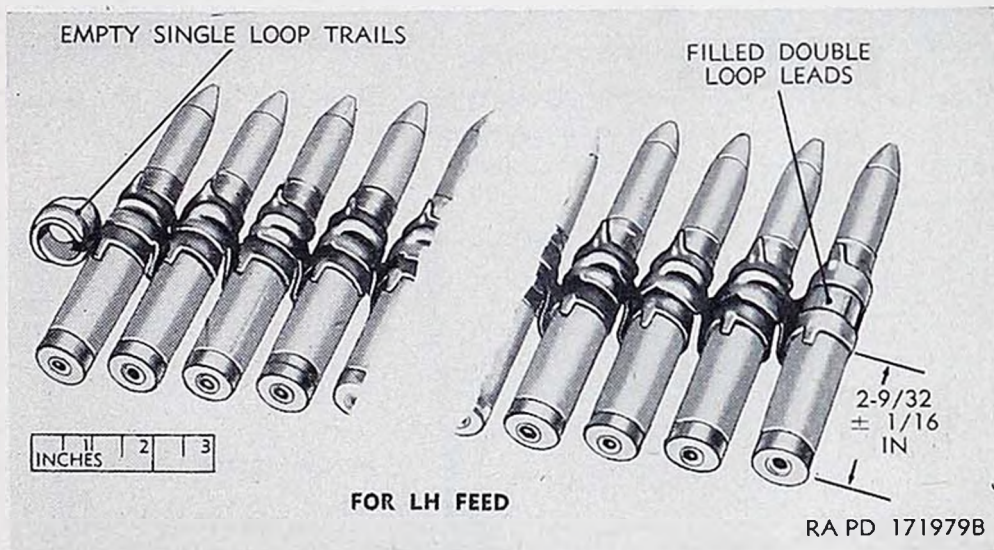

Figure 28. Loaded belt for double-loop light-hand feed.

20. Machine Loading of Belts With the 20-MM Ammunition Linking Machine M13

a. *Adjustment.* The machine is provided with four lock nuts and two pusher adjusting bolts on the pusher bar (figs. 29 and 30) to regulate the length of the stroke. These should be set so that the distance between the face of the pusher bar and the rear of the link stop is $3\frac{11}{16}$ to $3\frac{13}{16}$ inches when the cartridge pusher assembly is in the forward position. This adjustment must be made prior to the loading of the belts.

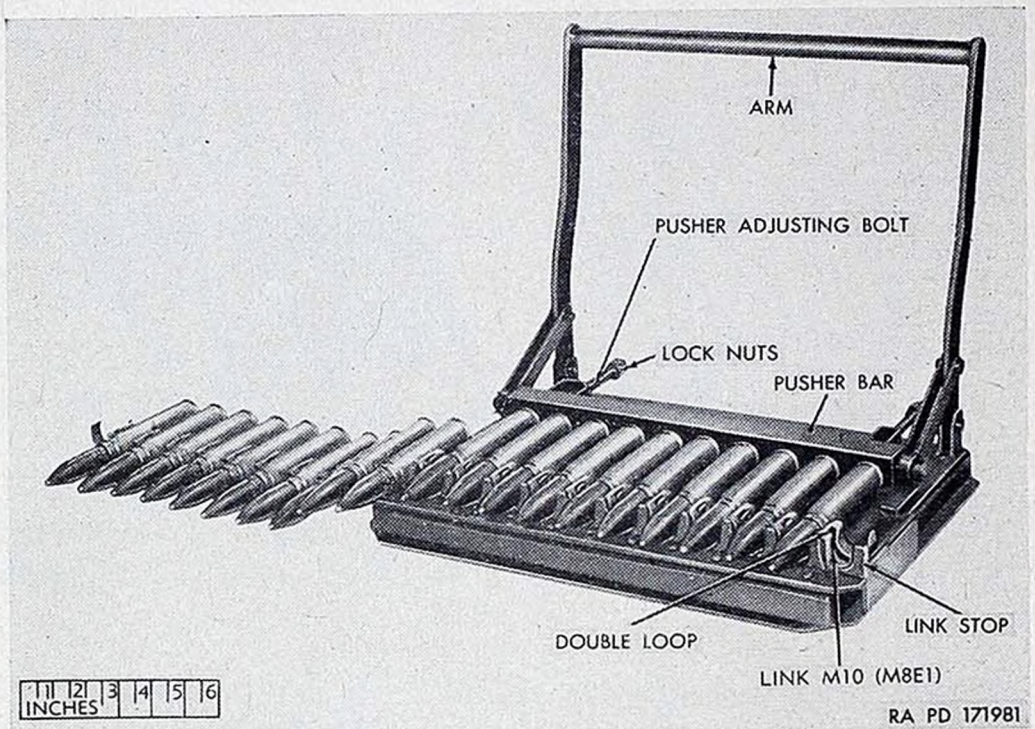

Figure 29. Belting ammunition for right-hand feed, using 20-mm ammunition linking machine M13.

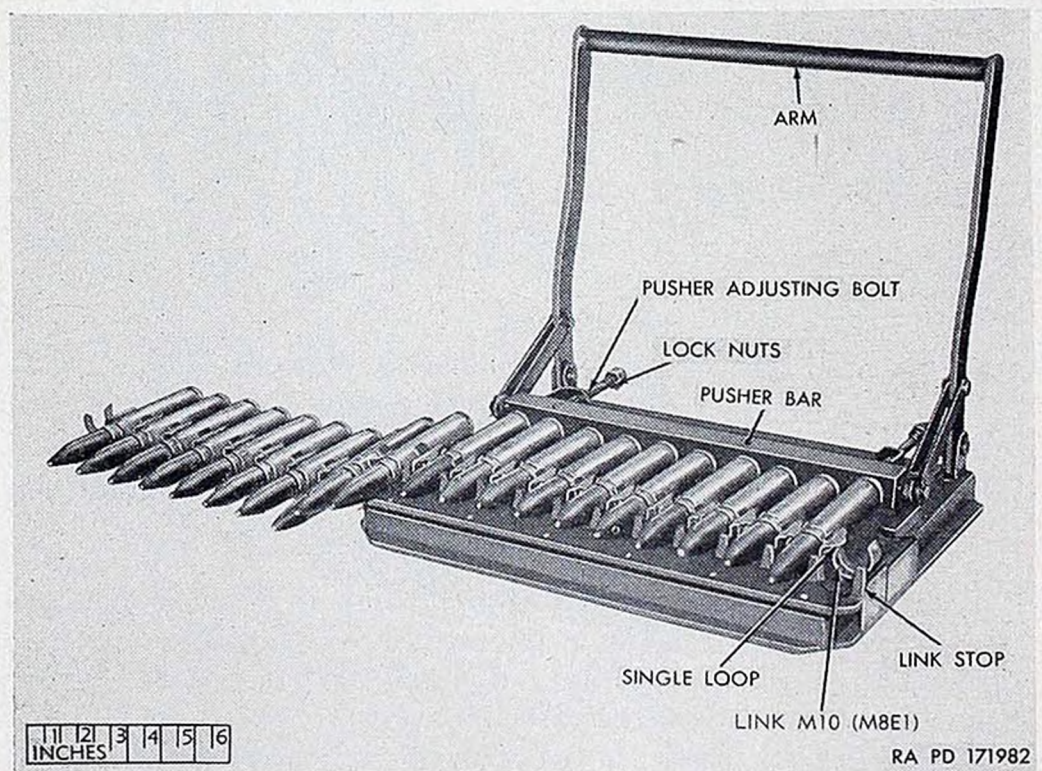

Figure 30. Belting ammunition for left-hand feed, using 20-mm ammunition linking machine M13.

RESTRICTED—Security Information

b. For Single-Loop Right-Hand Feed (fig. 29).

- (1) Inspect the links and lubricate them as directed in paragraph 19a (2).
- (2) Cartridge cases are coated with a wax film at manufacture. They should be kept clean and free of dust and dirt and shaded from direct rays of the sun.
- (3) Place 11 links M10 (M8E1) in a continuous row along the link guide, with their open sides up, and with double loops to the right and single loops positioned between the double loops.
- (4) Place 10 cartridges in the 10 central grooves of the cartridge guide, with their noses resting in the links.
- (5) Pull the cartridge pusher arm down with a steady pressure until the stroke is stopped by the lock nuts on the two pusher adjusting bolts.
- (6) Push back the pusher arm. Lift out the 10 cartridges, which are now linked together, and place the left-end cartridge in the right-end groove. Place additional links and cartridges in the guides and repeat the operations until the belt is of the desired length.
- (7) Test belt for flexibility and oversize links as directed in paragraph 19b (3) and (4).

c. For Single-Loop Left-Hand Feed (fig. 30).

- (1) Inspect the links and lubricate them as directed in paragraph 19a (2).
- (2) Cartridge cases are coated with a wax film when manufactured. They should be kept clean and free of dirt and dust and shaded from direct rays of the sun.
- (3) Place 11 links M10 (M8E1) in a continuous row along the link guide, with their open sides up, and with double loops to the left and single loops positioned between the double loops.
- (4) Place 10 cartridges in the 10 central grooves of the cartridge guide, with their noses resting in the links.
- (5) Pull the cartridge pusher arm down with steady pressure until the stroke is stopped by the lock nuts on the two cartridge pusher adjusting bolts.
- (6) Push back the cartridge pusher arm. Lift out the 10 cartridges, which are now linked together, and place the right-end cartridge in the guides, and repeat the operation until the belt is of the desired length.
- (7) Test belt for flexibility and oversize links as directed in paragraph 19b (3) and (4).

RESTRICTED—Security Information

d. For Double-Loop Left-Hand Feed. Proceed as in *b* above but insert a filler piece in the single loop at the end of the belt.

21. Adjusting Gun for Left- or Right-Hand Feed

a. General. When the gun is adjusted for either right- or left-hand feed, the charger, firing pin contact, breechblock contact and cover, magazine slide anchor, and operating lever bracket must be in the positions indicated below:

<i>LH Feed</i>		<i>RH Feed</i>
On right side.....	Charger.....	On left side
On left side.....	Firing pin contact (fig. 31).....	On right side
On left side.....	Breechblock contact and cover (fig. 31).....	On right side
On left side.....	Magazine slide anchor.....	On right side
On left side.....	Operating lever bracket (fig. 34).....	On right side

b. Changing From Right-Hand Feed to Left-Hand Feed.

- (1) Remove charger from right side of gun and install it on left side of gun. Refer to paragraph 18 for installation and removal of 20-mm manual charger M6 and 20-mm pneumatic charger M4.
- (2) Remove driving spring guide and driving spring or springs (par. 66*a*).
- (3) Remove rear buffer assembly (par. 66*c*).
- (4) Remove electrical gun firing contact parts (par. 81*b* or *c*).
- (5) Remove breechblock assembly (par. 70). Remove the firing pin contact from the right side of bolt assembly and install it on the left side (pars. 71 and 73).
- (6) Install breechblock assembly (par. 74).
- (7) Install electrical gun firing contact parts (par. 81*e* or *f*) on left side.
- (8) Install rear buffer assembly and driving spring group (par. 68).
- (9) Remove magazine slide anchor and anchor support bracket from right side and install it on left side as directed in (*a*) through (*f*) below.
 - (*a*) Remove cotter pin, magazine slide anchor screw lock washer, and magazine slide anchor screw (fig. 32). Remove the two locking nuts and lock washer and remove the magazine slide anchor (fig. 32).
 - (*b*) Remove the locking wire, unscrew the two anchor support bracket screws, and remove the anchor support bracket (fig. 32). Remove the two screws from left-hand trunnion block and use them to secure the right-hand trunnion block to the cradle. Lock-wire the screws.

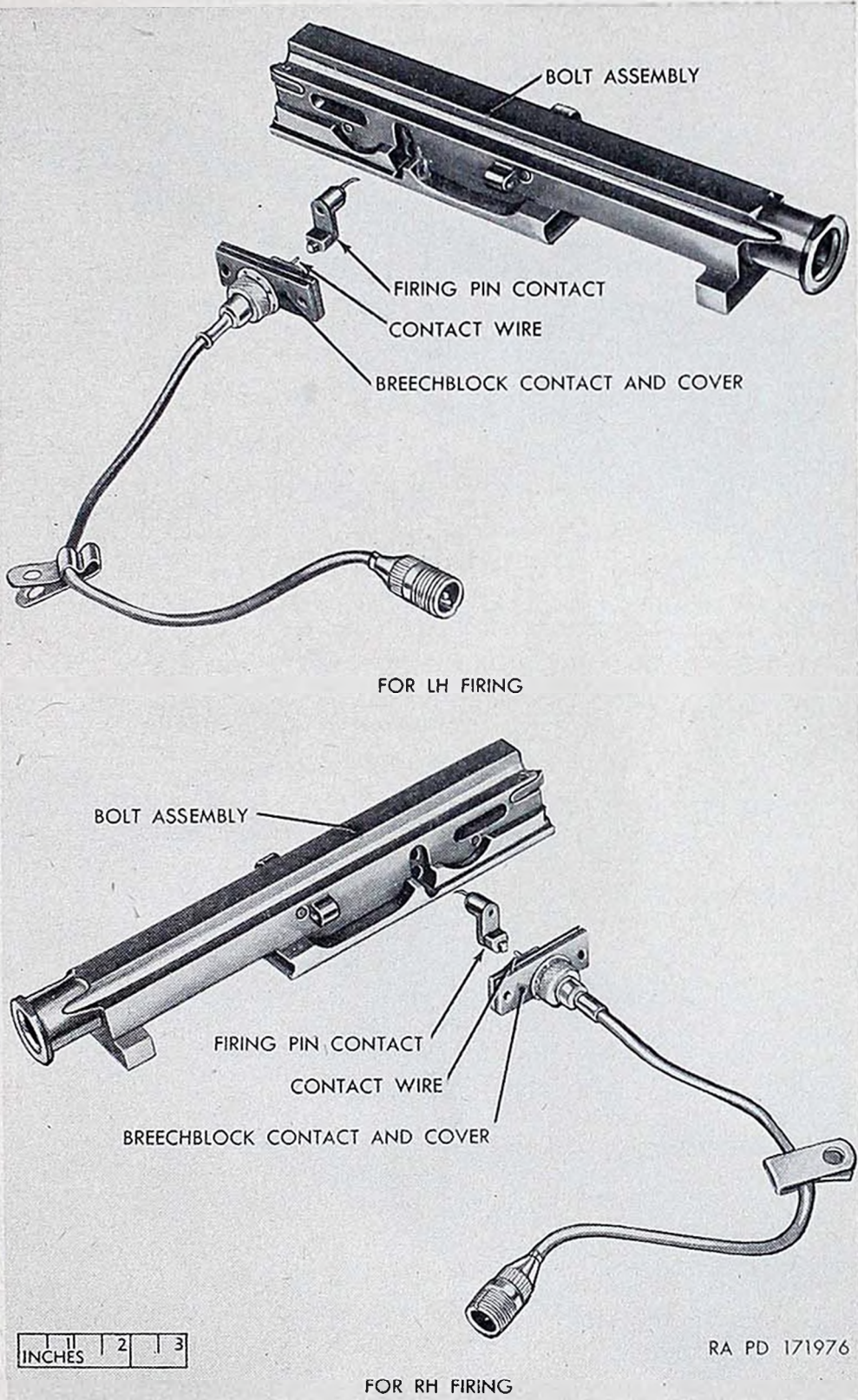

Figure 31. Position of firing pin contact and breechblock contact and cover for left-hand and right-hand feed.

RESTRICTED—Security Information

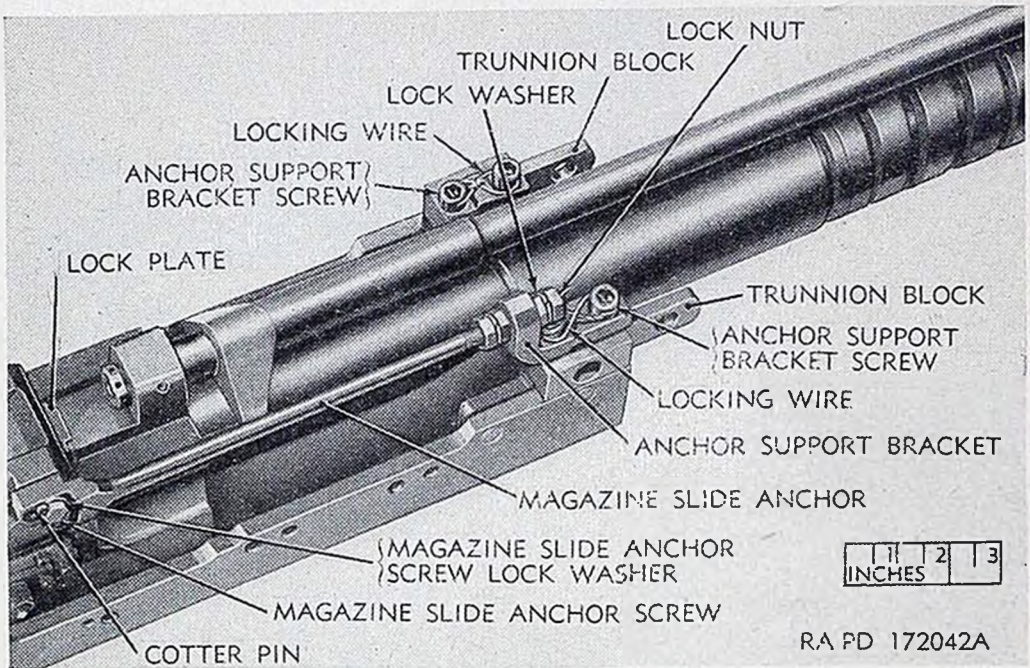

Figure 32. Removal of magazine slide anchor and support bracket from right side.

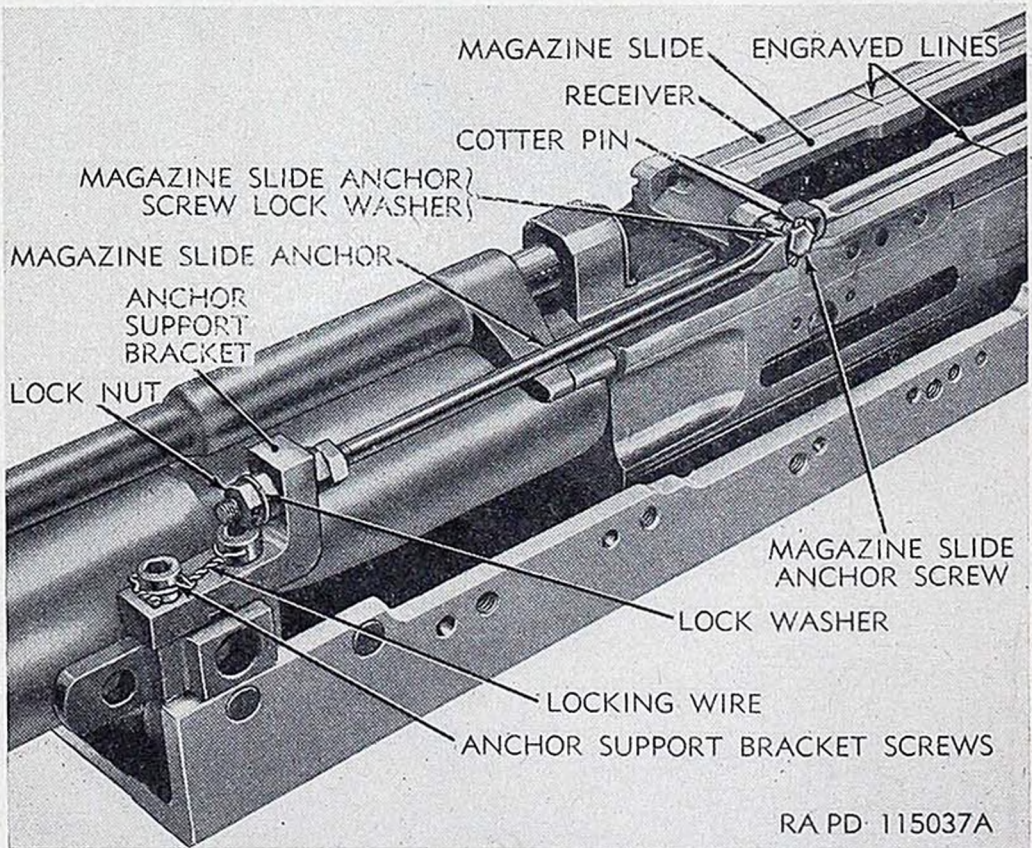

Figure 33. Installation of magazine slide anchor and support bracket on left side.

RESTRICTED—Security Information

- (c) Install the anchor support bracket on the left-hand trunnion block, with horizontal arm of the bracket pointing toward the muzzle end of the gun. Use two anchor support bracket screws to fasten the anchor support bracket and secure the screws with locking wire (fig. 33).
 - (d) Push the threaded end of the magazine slide anchor forward through the hole in the anchor support bracket. The threaded portion should face the muzzle end of the gun.
 - (e) Fasten the magazine slide anchor in place with the magazine slide anchor screw, magazine slide anchor screw lock washer, and cotter pin (fig. 33).
 - (f) Install the two locking nuts and lock washer on the front of the magazine slide anchor and adjust the front and rear locking nuts so that the engraved lines on the receiver and the magazine slide aline. This adjustment must be made when the gun is cold.
- (10) Cut the locking wire, unscrew the operating lever bracket screws, and remove operating lever bracket (fig. 34) from right side of receiver. Install the operating lever bracket on the left side of the receiver and secure with two operating lever bracket screws and locking wire.

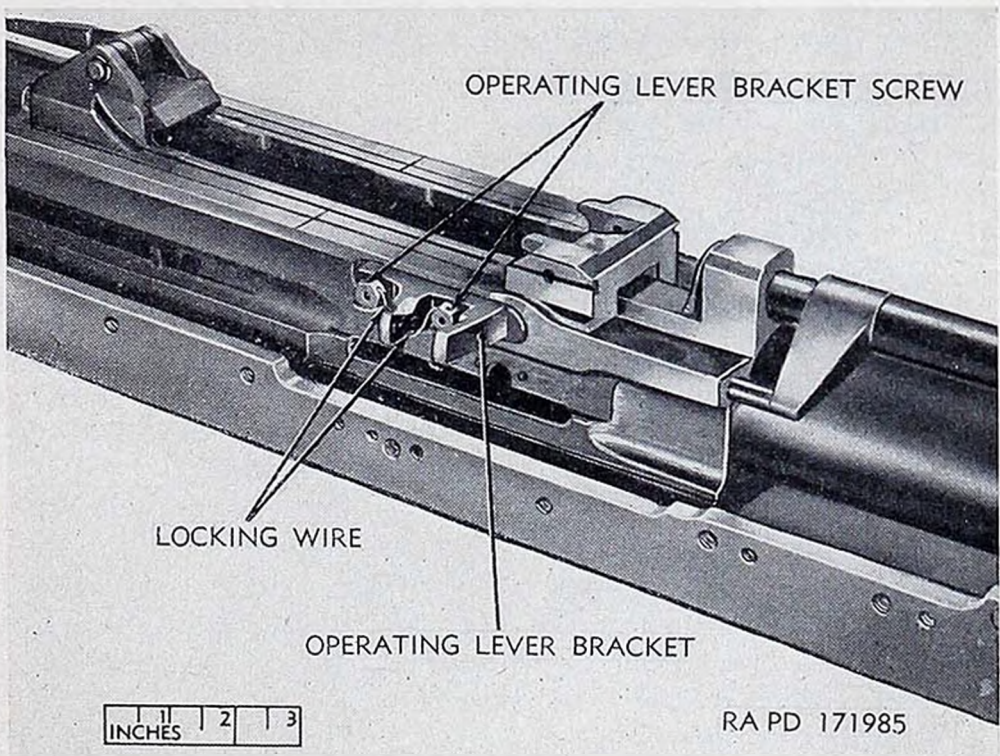

Figure 34. Adjustment of magazine slide and installation of operating lever bracket.

RESTRICTED—Security Information

c. Changing From Left-Hand Feed to Right-Hand Feed.

- (1) Remove charger from left side of gun and install it on right side of gun. Refer to paragraph 18 for installation and removal of 20-mm manual charger M6 and 20-mm pneumatic charger M4.
- (2) Remove driving spring guide and driving spring or springs (par. 66*a*).
- (3) Remove rear buffer assembly (par. 66*c*).
- (4) Remove electrical gun firing contact parts (par. 81*b* or *c*).
- (5) Remove breechblock assembly (par. 70). Remove the firing pin contact from the left side of bolt assembly and install it on the right side (par. 71 and 73).
- (6) Install breechblock assembly (par. 74).
- (7) Install electrical gun firing contact parts (par. 81*e* or *f*) on right side.
- (8) Install rear buffer assembly and driving spring group (par. 68).
- (9) Remove magazine slide anchor and anchor support bracket from left side and install it on right side as directed in (*a*) through (*f*) below.
 - (*a*) Remove cotter pin, magazine slide anchor screw lock washer, and magazine slide anchor screw (fig. 32). Remove the two locking nuts and lock washer and remove the magazine slide anchor (fig. 32).
 - (*b*) Remove the locking wire, unscrew the two anchor support bracket screws, and remove the anchor support bracket (fig. 32). Remove the two screws from right-hand trunnion block and use them to secure the left-hand trunnion block to the cradle. Lock-wire the screws.
 - (*c*) Install the anchor support bracket on the right-hand trunnion block, with horizontal arm of the bracket pointing toward the muzzle end of the gun. Use two anchor support bracket screws to fasten the anchor support bracket and secure the screws with locking wire (fig. 33).
 - (*d*) Push the threaded end of the magazine slide anchor forward through the hole in the anchor support bracket. The threaded portion should face the muzzle end of the gun.
 - (*e*) Fasten the magazine slide anchor in place with the magazine slide anchor screw, magazine slide anchor screw lock washer, and cotter pin (fig. 33).
 - (*f*) Install the two locking nuts and lock washer on the front of the magazine slide anchor and adjust the front and rear locking nuts so that the engraved lines on the receiver and

RESTRICTED—Security Information

the magazine slide aline. This adjustment must be made when the gun is cold.

- (10) Cut the locking wire, unscrew the operating lever bracket screws, and remove operating lever bracket (fig. 34) from left side of receiver. Install the operating lever bracket on the right side of the receiver and secure with two operating lever bracket screws and locking wire.

22. Installation of Feed Mechanism

a. Before installing feed mechanism, make certain the charger, firing pin contact, breechblock contact and cover, magazine slide anchor, and operating lever bracket are installed as indicated in paragraph 21*a*.

Note. The operations and installation shown in figures 35, 36, and 37 for the AN-M2 mechanism are also applicable to the M2E4 and M2E5 mechanisms.

b. Check adjustment of magazine slide (par. 21*b*(9)(*f*)).

c. Position the feed mechanism on the gun, with winding nut toward the muzzle of the gun, push feed mechanism forward until it engages the recesses at the forward part of the magazine slide, as shown in figure 35.

d. Raise the magazine latch lever and exert downward pressure on the rear part of the feed mechanism until it is seated in place past the magazine latch. Release the magazine latch lever.

e. Make certain that the operating lever is latched to the operating

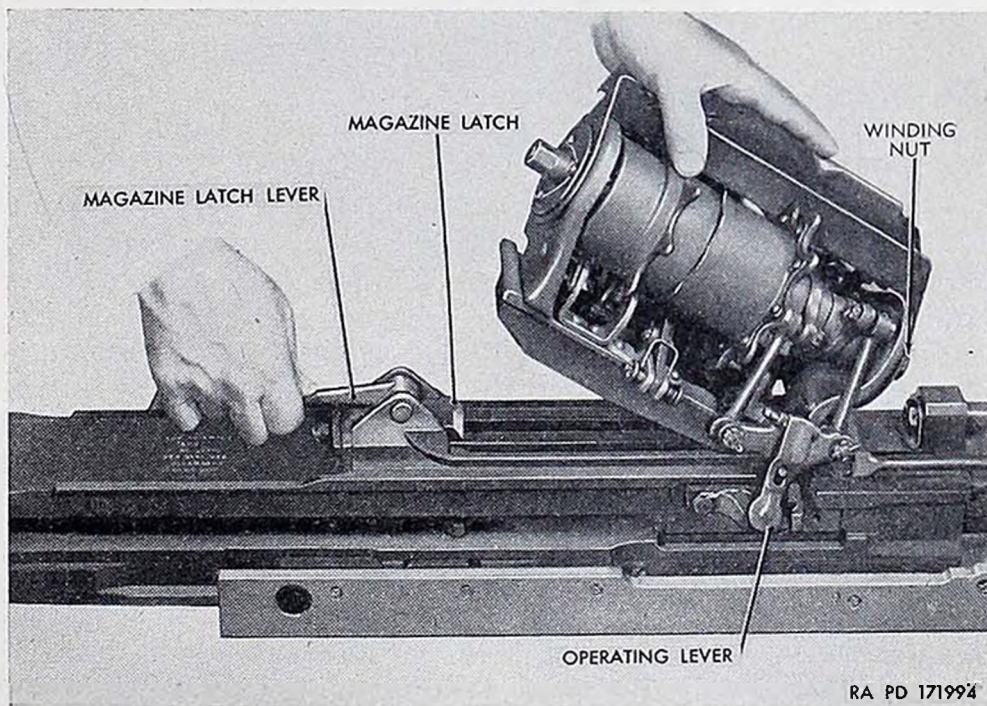

Figure 35. Installation of feed mechanism.

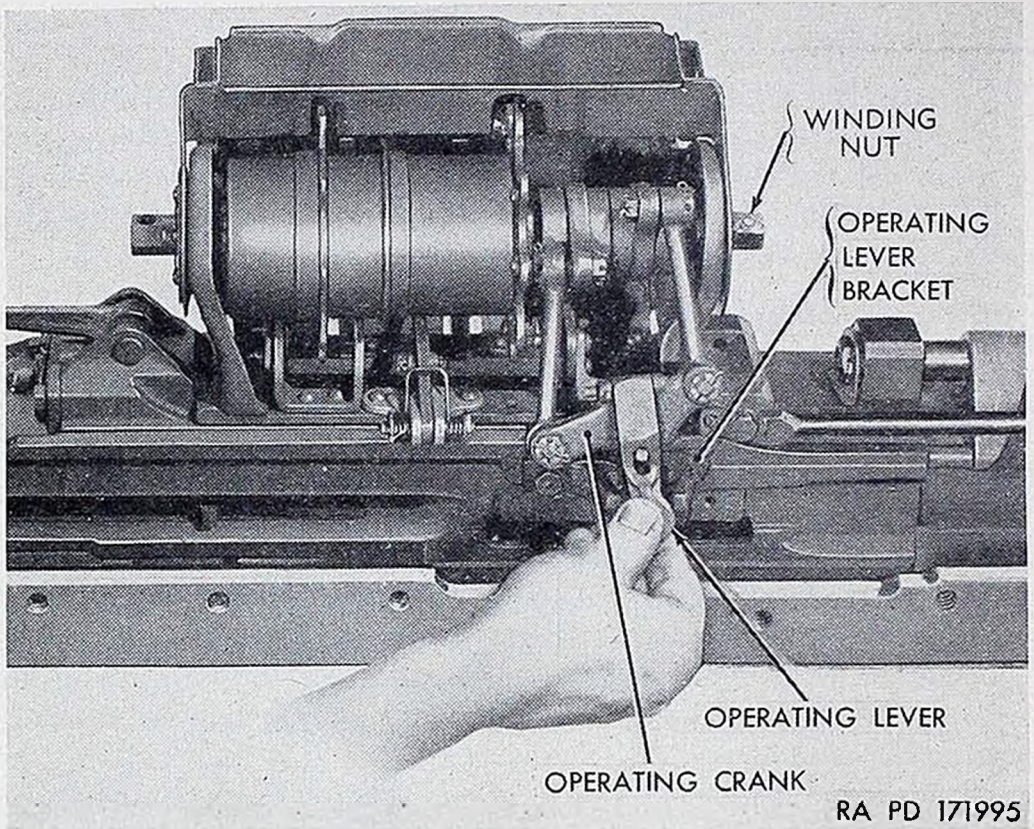

Figure 36. Positioning the operating lever of feed mechanism.

crank (fig. 36). Press the operating lever in between the lugs of the operating lever bracket until the mechanism is secured as shown in figure 37.

23. Installation of Feed Chute and Cover

Note. The operations shown in figures 39, 40, and 41 for the AN-M2 mechanism are also applicable to the M2E4 and M2E5 mechanisms.

a. Normally, ammunition can be fed into the feed mechanism at an angle of 75° above horizontal through the feed chute adapter (fig. 38), which is pivoted about the end bearings of the feeder. However, feed covers are available that will give angles of feed ranging from 55° above horizontal to 47° below horizontal, as shown in figure 38.

b. Feed mechanism covers are inserted between the feed frame and the feed chute adapter (fig. 39). Unlatch the adapter from the feed frame and swing the adapter up. Install the feed cover and latch it to the feed frame and then latch the feed chute adapter to the feed cover (fig. 39).

Note. The covers for the right-hand and left-hand feed mechanisms differ. When the proper cover is installed, the contour of the cover and the feed chute adapter will match. The installation of the wrong cover will result in failure to feed. These feed covers are Air Force equipment and are not issued by the Ordnance Corps.

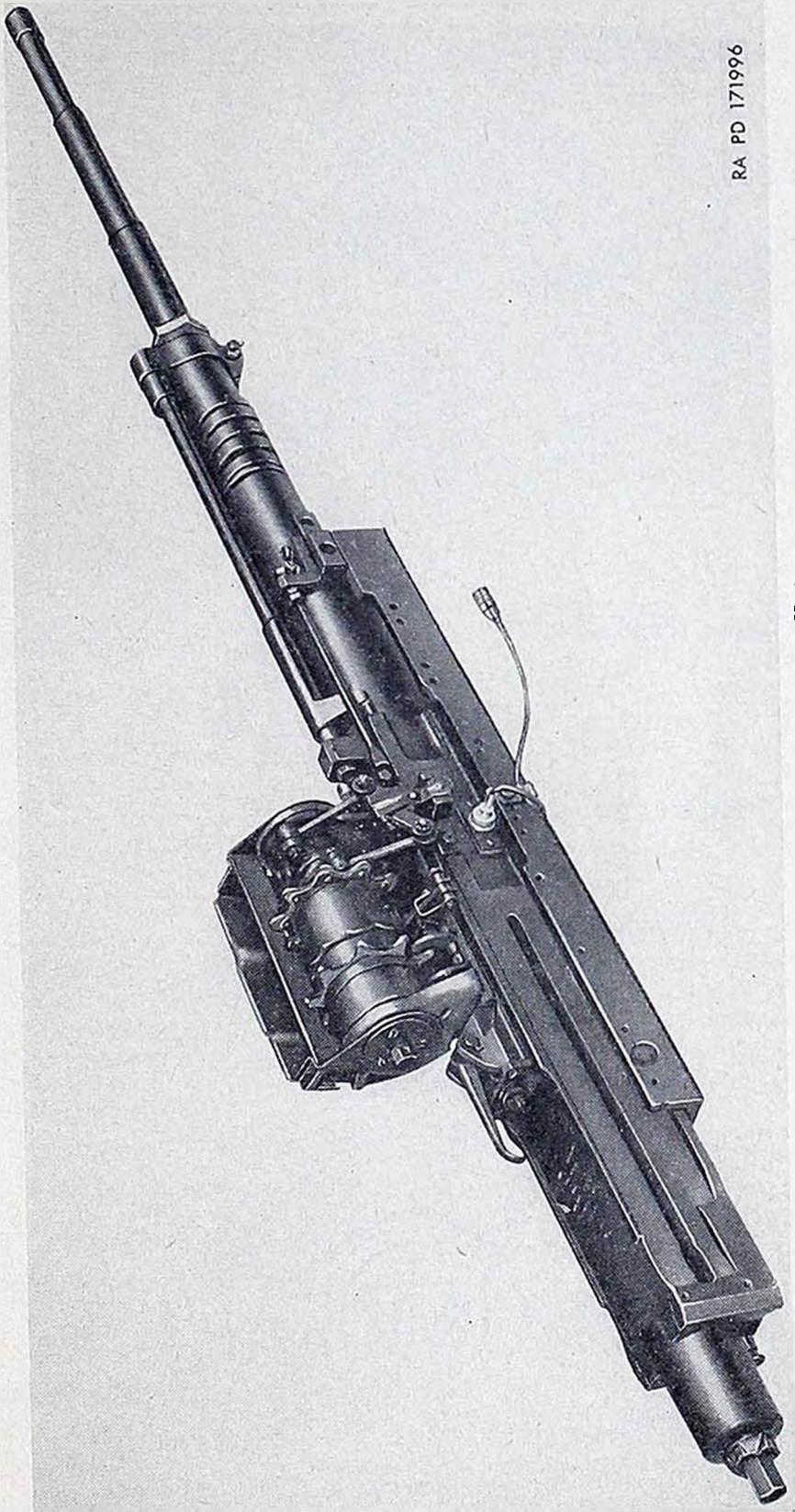

RA PD 171996

Figure 37. Feed mechanism installed on gun.

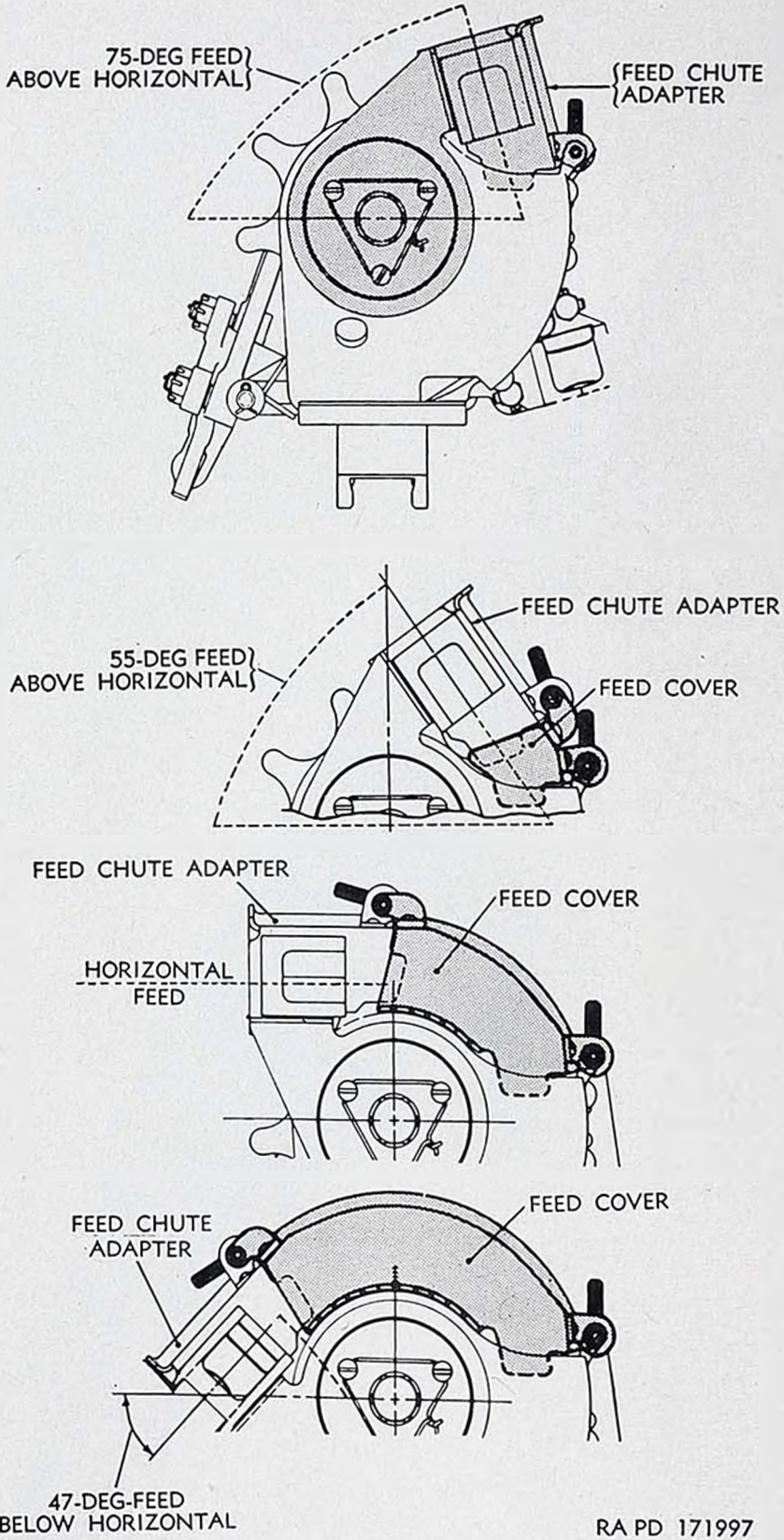

RA PD 171997

Figure 38. Ammunition entrance angles of 20-mm feed mechanisms.

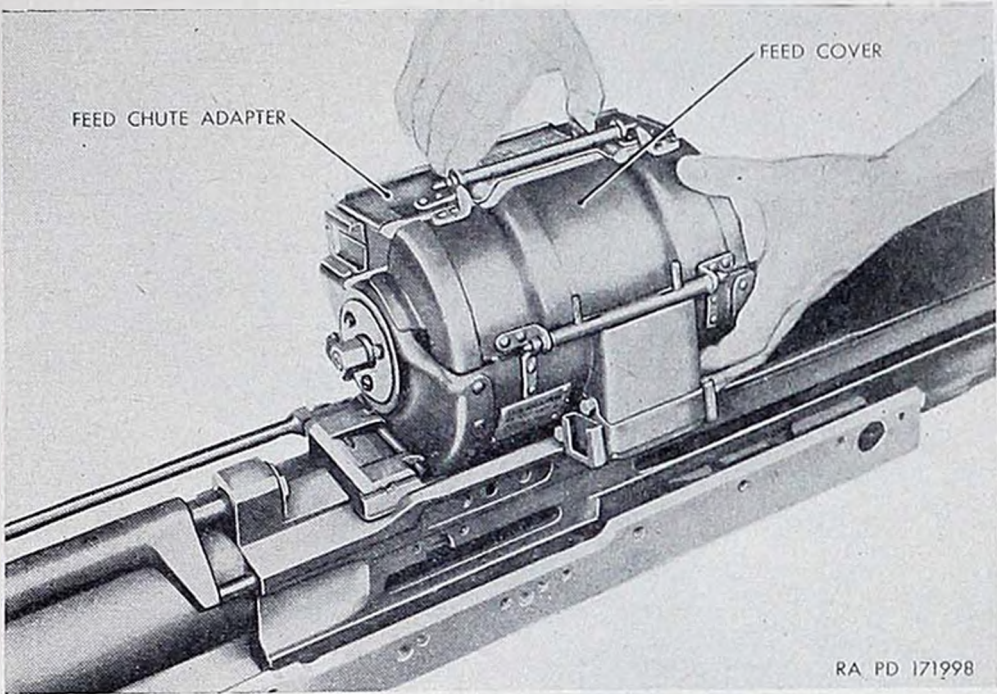

Figure 39. Installation of feed cover.

c. Hold the end of the feed chute marked "GUN END" near the feed chute adapter so that the spring latches of the chute align with the latch guides of the feed chute adapter (fig. 40). Push the chute forward against the adapter until the latches snap into position in the latch guides.

Note. Feed chutes (Air Force equipment) may be either the symmetrical type or the form-fitting type. With the symmetrical type, the open side may be either upward or downward, as desired; with the form-fitting type, the long, narrow end of the feed chute (fig. 40) must point toward the muzzle and the short, wide end toward the rear buffer assembly. The form-fitting type can be reversed from open side up to open side down by changing the feed from right-hand to left-hand or vice versa.

24. Loading the Feed Mechanism

a. For single-loop left-hand or right-hand feed, take the empty single loop of a belt of ammunition, closed loops upward, draw it through the feed chute, and insert it into the feed mechanism; for double-loop left-hand feed, take the double filled loop of a belt of ammunition, closed loops upward, draw it through the feed chute, and insert it into the feed mechanism.

Note. For single-loop, left-hand or right-hand feed, a filler piece may be used in the leading single empty loop but is not required; for double-loop left-hand feed, a filler piece must be used in the single loop at the end of the belt.

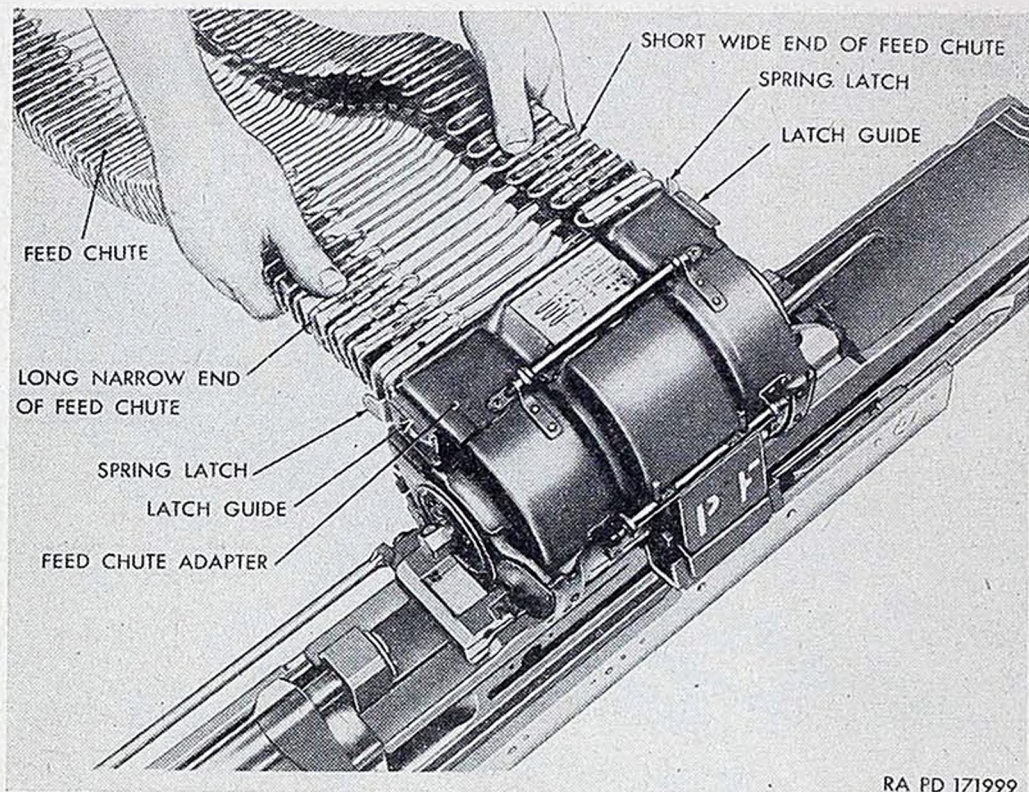

RA PD 171999

Figure 40. Installation of feed chute.

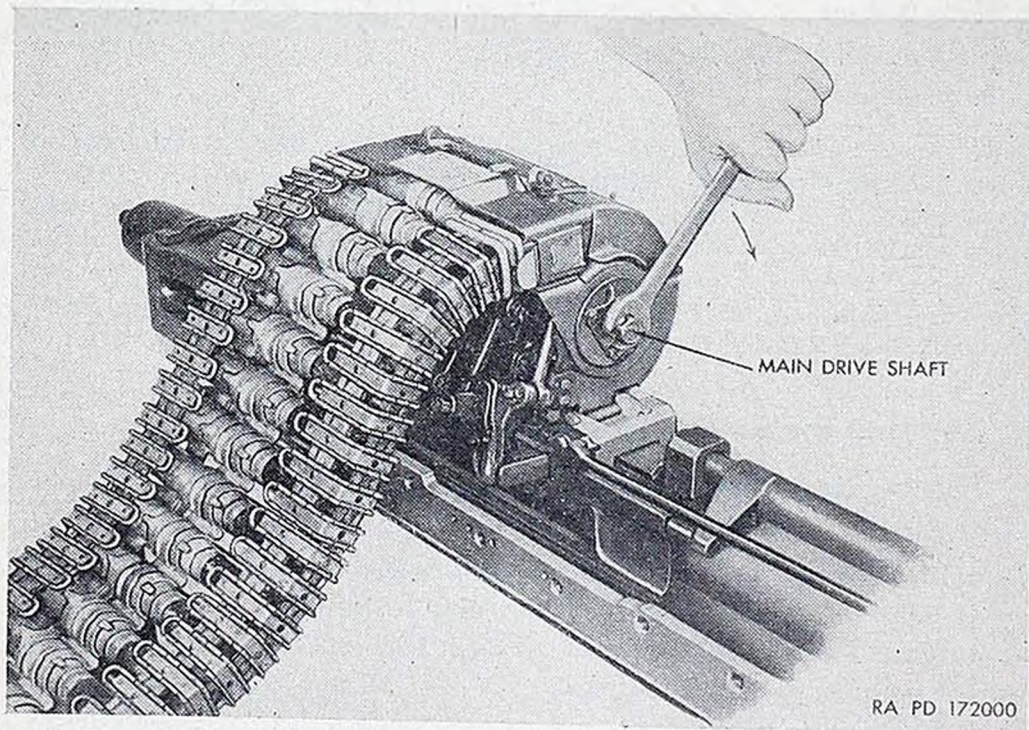

RA PD 172000

Figure 41. Loading the feed mechanism.

RESTRICTED—Security Information

When the first round engages the star wheel tooth, push as many rounds as possible into the feed mechanism.

b. Wind the feed drive spring by continuing to rotate the main drive shaft (fig. 41) about three-quarters to one turn (until you feel the spring slip) after the round has been forced into the mouth of the mechanism.

Note. Torque-stabilizer action protects the drive spring against damage from over winding.

25. Charging the Gun

a. *Pneumatic Charger M4.*

- (1) Open the cylinder valve of the storage cylinder (fig. 42). The cylinder contains gas or air under pressure.

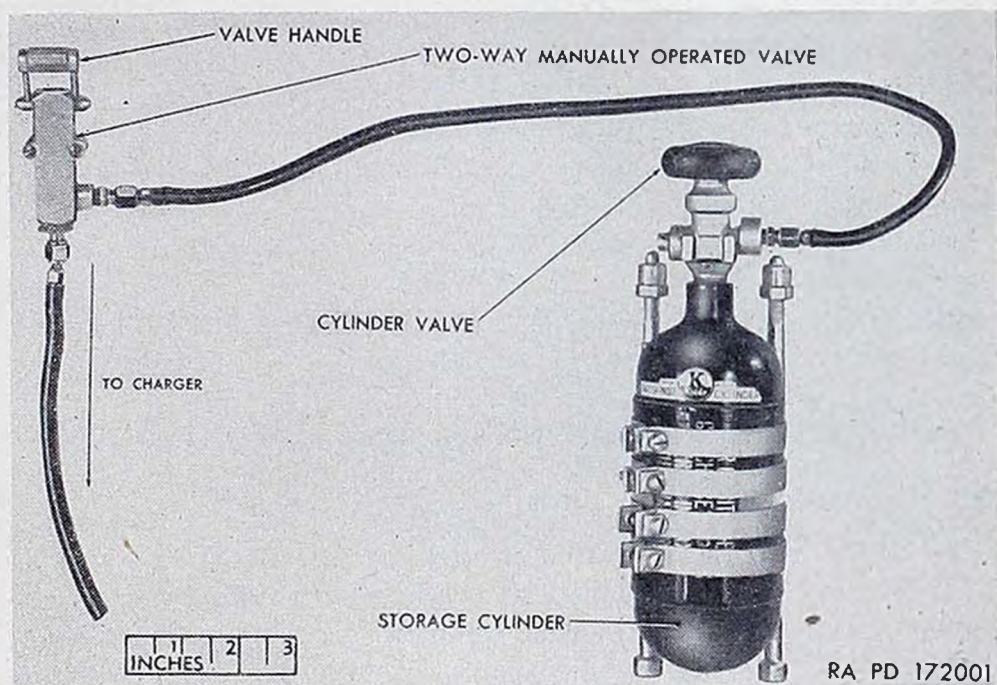

Figure 42. Controls for 20-mm pneumatic charger M4.

- (2) Move the valve handle of the two-way, manually operated valve (fig. 42) and release it after a 1-second delay or close the valve switch of the solenoid-controlled valve and break the circuit by means of another switch.

b. *Manual Charger M6.* To activate the gun, rapidly pull the charger cable its full length to move the breechblock to the rear, then release the charger cable. This charger has an automatic release that permits the breechblock to return to breech closing position at a point near full length of the cable.

26. Firing the Gun

The firing switch for firing the gun is located in the aircraft. When the gun has been charged and the round seated in the chamber, closing of the switch causes the current to flow through the system and fire the round.

- a.* To fire the gun, close the firing switch.
- b.* To cease firing, release the firing switch.

Note. In case of failure to fire, refer to paragraphs 59 through 62.

27. Unloading the Gun

Note. The operation shown in figure 43 for the AN-M2 mechanism is also applicable to the M2E4 and M2E5 mechanisms.

- a.* Shut off armament safety switch.
- b.* If the rounds of ammunition in the belt have been completely expended, the star wheel housing will spin and automatically unwind the drive spring. Disconnect the feed chute, disengage the operating lever, release the magazine latch, and remove the feed mechanism.
- c.* If the rounds of ammunition in the belt have not been completely expended, it will be necessary to unwind the drive spring. Push shaft in about three-sixteenths of an inch (fig. 43) and, at the same time, rotate the shaft about three-quarters of a turn in the direction opposite to that of winding. Pull the belt from the feed mechanism and then proceed as in *b* above.

Section III. OPERATION UNDER UNUSUAL CONDITIONS

28. General

In addition to the operating procedures described in paragraphs 13 through 27 for usual conditions, special instructions for the operation of the materiel under unusual conditions are contained or referred to herein. In addition to the normal preventive maintenance services, special care in cleaning and lubrication must be observed where extremes of temperature, humidity, and terrain conditions are present or anticipated. Proper cleaning, lubrication, and storage and handling of lubricants not only insure proper operation and functioning of the materiel but also guard against wear of the working parts and deterioration of the materiel.

29. Extreme-Cold Weather Conditions

a. General. Extensive preparation are necessary for materiel scheduled to operate in extremely cold weather. It is necessary that the moving parts of the gun and its equipment be kept absolutely free

RESTRICTED—Security Information

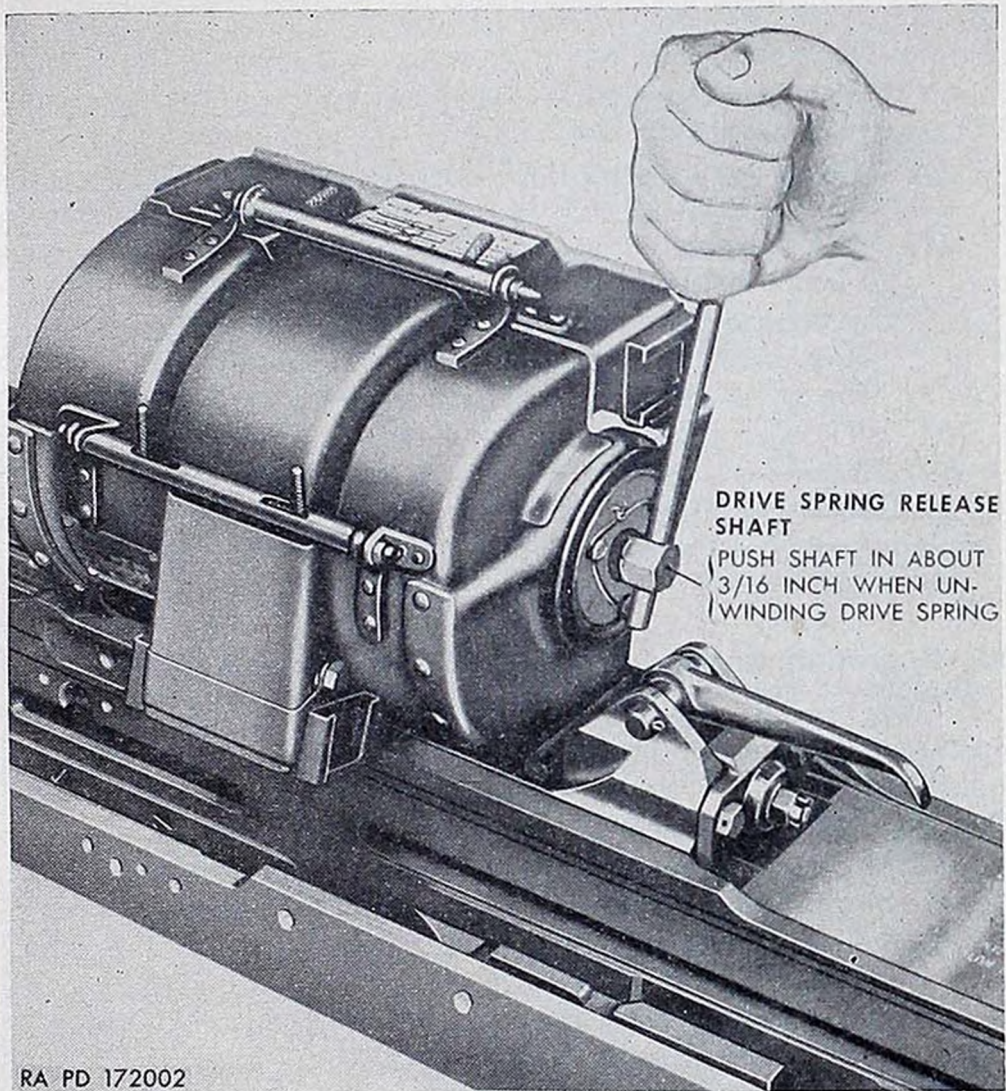

Figure 43. Unloading the feed mechanism.

of moisture. More oil than necessary on the working parts will solidify and cause sluggish operation or even complete failure. This applies particularly to the firing mechanism and small spring-operated parts. Special care should be taken to eliminate this condition from the following:

- Bore of tube.
- Breechblock slide assembly.
- Firing pin, firing pin guide and spring, and tunnel in bolt.
- Breechblock lock.
- Driving spring group.
- Barrel plate, plunger, and spring.

RESTRICTED—Security Information

b. Storage, Handling, and Use of Lubricants.

- (1) The performance of equipment at arctic temperatures will depend, to a great extent, upon the condition of the lubricants used for the equipment.
- (2) The manner in which the lubricants are stored, handled, and used will greatly affect the service the lubricants will render.
- (3) In arctic operations, contamination by moisture is the source of many difficulties. Such contamination may be caused by the presence of snow in the product, by condensation due to "breathing" of a partially filled container, or by condensation from warm air in a partially filled container when a product is taken outdoors from room temperatures.
- (4) Immediate affects of careless storage and handling or improper use of lubricants are not always apparent, but any deviation from proper procedures may cause trouble at the least expected time.

30. Operation Under Extreme-Cold Weather Conditions

a. Cover the gun, when it is not in use, for protection and to prevent frosting. Keep breech and firing mechanisms extremely clean and lightly lubricated. Check frequently recoil mechanism and feed mechanism for sluggishness.

b. When cleaning, do not dilute rifle-bore cleaner or add an anti-freeze. Store cleaning solutions in a warm place, if practicable. Shake rifle-bore cleaner well before using. It is essential that all moving parts be kept absolutely free of moisture. When applying oil to the bore after cleaning, work the oil in well so that it will reach all surfaces of the lands and grooves.

c. When a cold gun is brought into a heated shop, condensation will occur on all metal surfaces of the gun. In order to prevent rusting, wipe all parts dry and coat them with oil as soon as the gun has reached shop temperature.

31. Operation Under Extreme-Hot Weather Conditions

a. In hot climates, the thin film of oil necessary for guns under combat conditions is dissipated quickly. Inspect guns frequently and renew oil film, as often as is necessary, to prevent rusting and keep the gun ready for combat when mounted in aircraft. Clean guns frequently to remove dust or grit from oiled surfaces.

b. Keep guns covered as much as possible.

c. Perspiration from the hands is a contributing factor to rusting because it contains acid. When handled, guns should be wiped dry frequently and the oil film renewed.

RESTRICTED—Security Information

d. Where humidity is high, take special care to inspect unexposed surfaces, such as bore and chamber of tube, breechblock assembly, and driving springs, where rusting might occur without timely detection. Watch screws and pins to prevent rusting and "freezing" in place.

e. Keep ammunition out of direct rays of the sun. Do not break moisture resistant seals until ammunition is to be used.

32. Operation Under Sandy or Dusty Conditions

a. In localities where dust and sand storms are prevalent, guns should be kept carefully covered at all times, whether mounted in the aircraft or not. Dust and sand enter the mechanism and bore and adhere to lubricated surfaces, forming a gummy paste that may clog gun and cause malfunctioning. This paste also acts as an abrasive and causes undue wear of the moving parts of the gun.

b. After a dust or sand storm, guns should be disassembled and thoroughly cleaned, inspected, and lubricated as outlined in paragraph 39.

33. Operation Under Moist or Salty Atmospheric Conditions

When the materiel is operated under moist or salty atmospheric conditions, clean and lubricate exposed metal surfaces more frequently because water emulsifies with oil and destroys its rust-preventive qualities. Inspect parts frequently for corrosion.

CHAPTER 3

ORGANIZATIONAL MAINTENANCE INSTRUCTIONS

Section I. PARTS SPECIAL TOOLS, AND EQUIPMENT FOR ORGANIZATIONAL MAINTENANCE

34. General

Tools, equipment, and spare parts are issued to the using organization for maintaining the materiel. Tools and equipment should not be used for purposes other than prescribed and, when not in use, should be properly stored in the chest and/or roll provided for them.

35. Parts

Organizational spare parts are supplied to the using organization for replacement of those parts likely to become worn, broken, or otherwise unserviceable, providing such operations are within the scope of organizational maintenance functions. Organizational spare parts supplied for the 20-mm automatic guns M24, M24A1, and M24E2, are listed in Department of Army Supply Catalog ORD 7 SNL A-73, which is the authority for requisitioning replacements. Organizational tools and equipment supplied for the 20-mm automatic guns M24, M24A1, and M24E2 are listed in Department of the Army Supply Catalog ORD 7 SNL A-73 and in the 20-mm automatic gun squadron tool set listed in ORD 6 SNL J-12.

36. Common Tools and Equipment

Standard and commonly used tools and equipment having general application to this matériel are listed in ORD 6 SNL J-10, Section 1, and are authorized for issue by T/O&E. They are not specifically identified in this manual.

37. Special Tools and Equipment

Certain tools and equipment specially designed for organizational maintenance, repair, and general use with the materiel are listed in table I for information only. This list is not to be used for requisitioning replacements.

Table I. Special Tools and Equipment for Organizational Maintenance

Item	Identifying number	References		Use
		Fig.	Par.	
BRUSH, bore, 20-mm, M25.....	7225087	44	46, 80c(3)	To clean and oil gun bore.
CHARGER, manual, 20-mm, M6.....	7227817	52	18	To charge gun.
CHARGER, pneumatic, 20-mm, M4.....	7228217	52	18	Do.
COVER, muzzle.....	7237710	44	46b(1)(a)	To protect gun bore from dirt and foreign matter.
or				
COVER, muzzle, 20-mm, M336 (early design).....	7230224		46b(1)(a)	Do.
EXTRACTOR, firing pin contact.....	7237734 (41-E-542-750)	44, 85, 106	71d	To remove firing pin contact.
GAGE, tube.....	7246264		115a(5)	To check remaining life of gun tube.
MACHINE, linking, 20-mm ammunition, M13, used with link M10 (M8E1).	7226304	29, 30, 45.	20	To load rounds into links M10 (M8E1).
MECHANISM, feed, 20-mm, AN-M2, LH.....	7225420	46, 47	22	To load ammunition into gun.
MECHANISM, feed, 20-mm, AN-M2, RH.....	7225419	48, 49	22	Do.
MECHANISM, feed, 20-mm, M2E4, LH.....	7306221	50	22	Do.
MECHANISM, feed, 20-mm, M2E4, RH.....	7306220	50	22	Do.
MECHANISM, feed, 20-mm, M2E5, LH.....	7306224	51	22	Do.
MECHANISM, feed, 20-mm, M2E5, RH.....	7306223	51	22	Do.
STAFF, cleaning, 20-mm, M13.....	5570631	44	46, 80c(3)	Used with bore brush to clean and oil gun bore.
TOOL, breechblock and firing pin spring plug assembling.	7237920	44, 86, 87	71, 73e, 74	To assemble breechblock and firing pin spring plug.
WRENCH, engrs, angle 15°, sgle open end, alloy-S, size of opng 1/16 in, lgh 7/4 in.	5206718 (41-W-1209-4C)	44, 92	76b, 78e	To remove and install gas cylinder guide.
WRENCH, rear buffer.....	5570605 (41-W-1990-400)	44, 79, 106	66a, 68e	To remove and install driving spring group.

RESTRICTED

55

RESTRICTED—Security Information

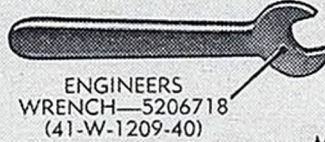
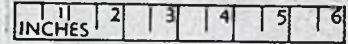
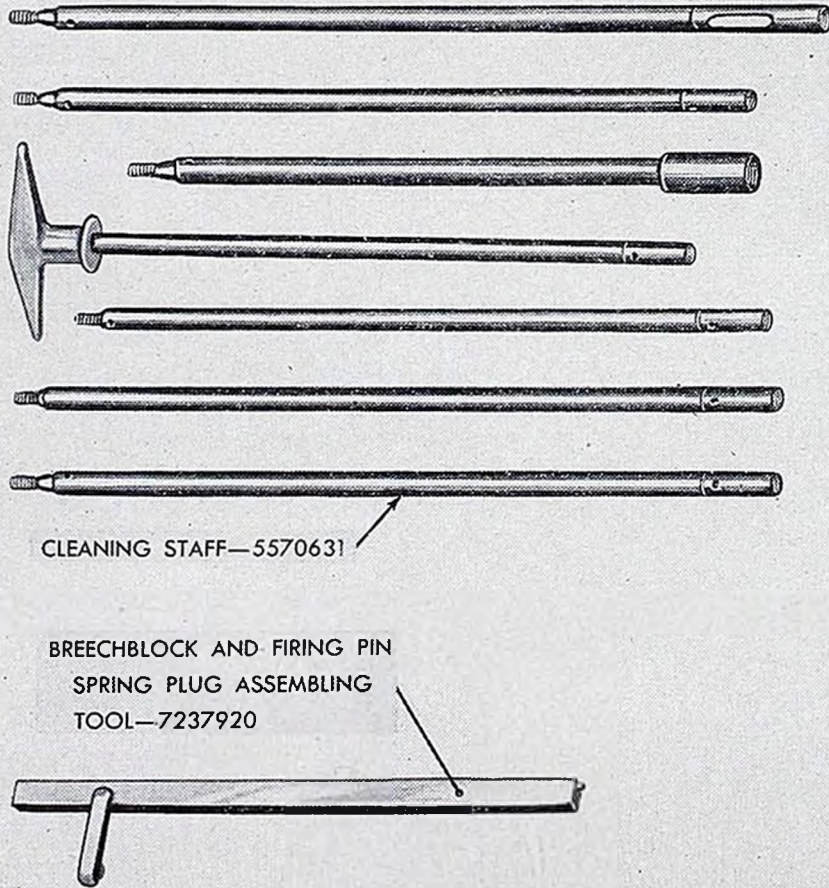

RA PD 172003

Figure 44. Special tools and equipment for organizational maintenance.

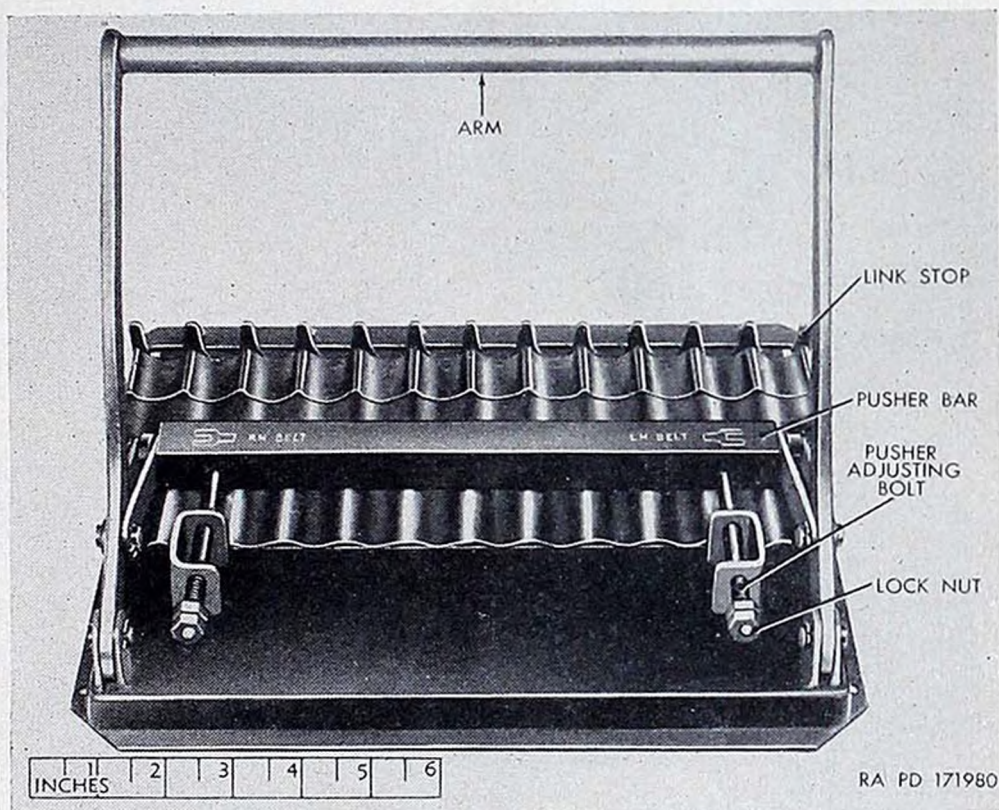

Figure 45. 20-mm ammunition linking machine M13.

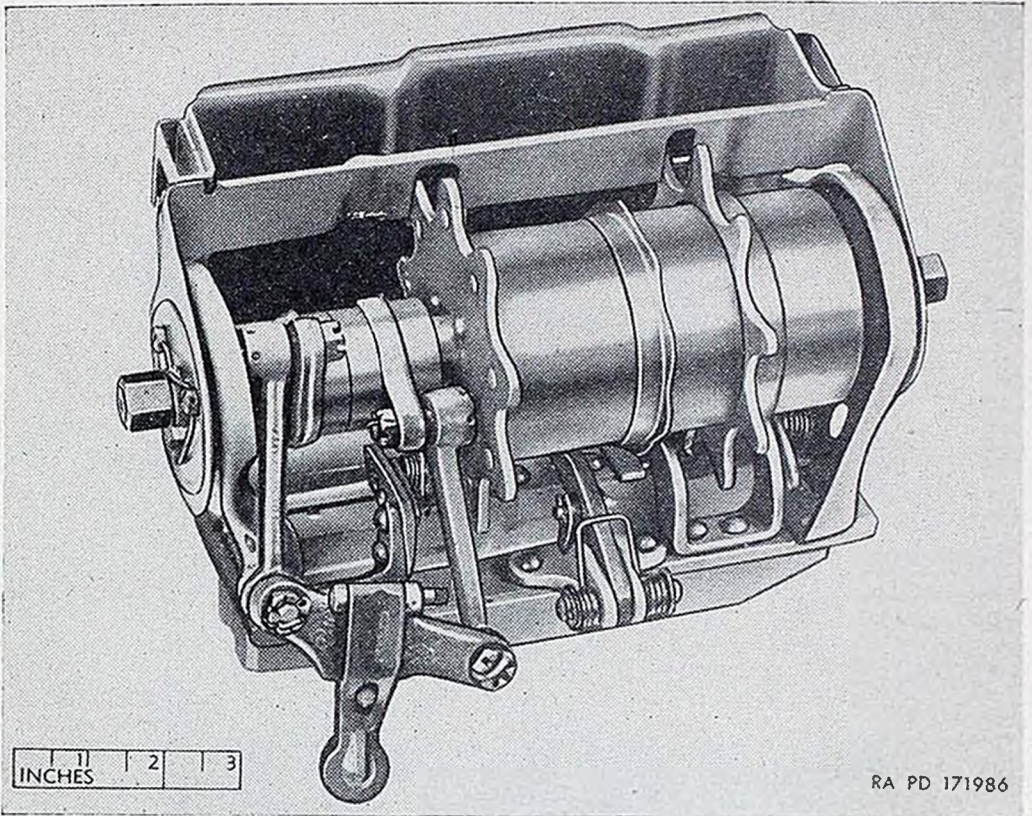

Figure 46. 20-mm feed mechanism AN-M2, left-hand—left-side view.

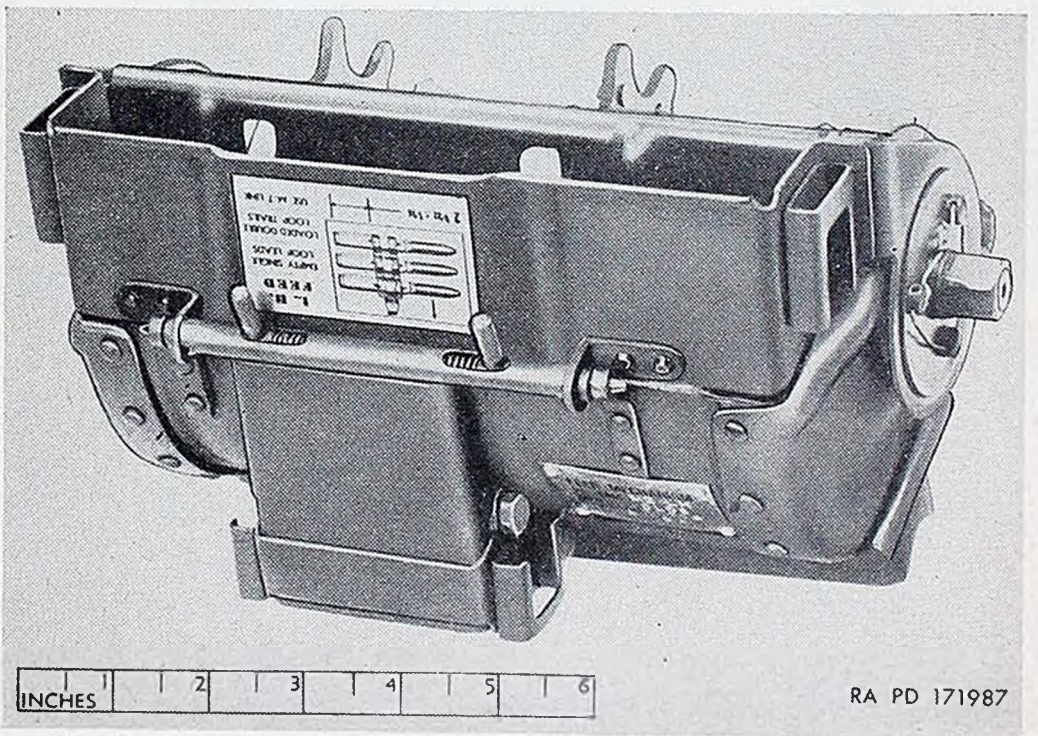
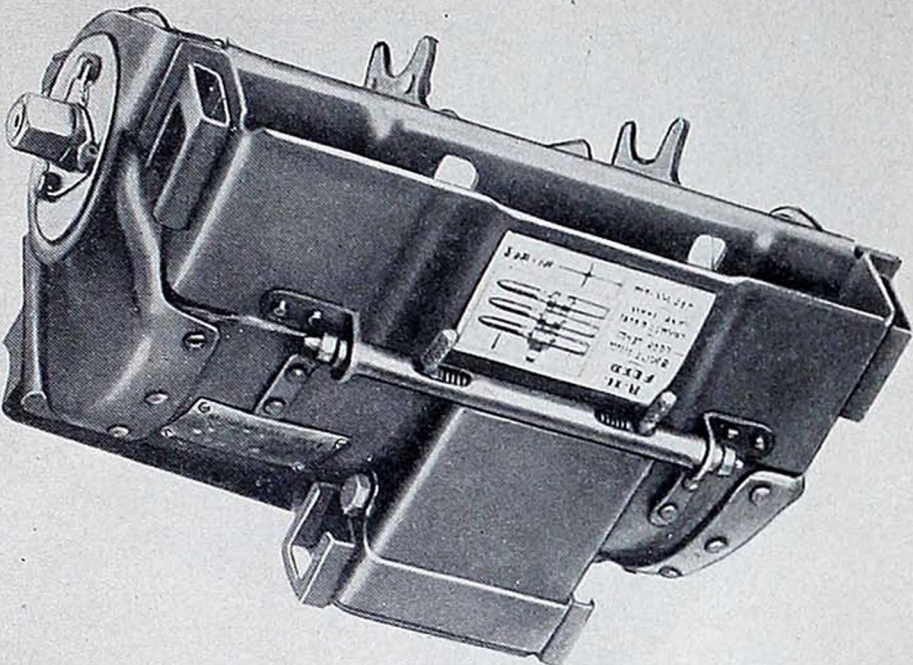
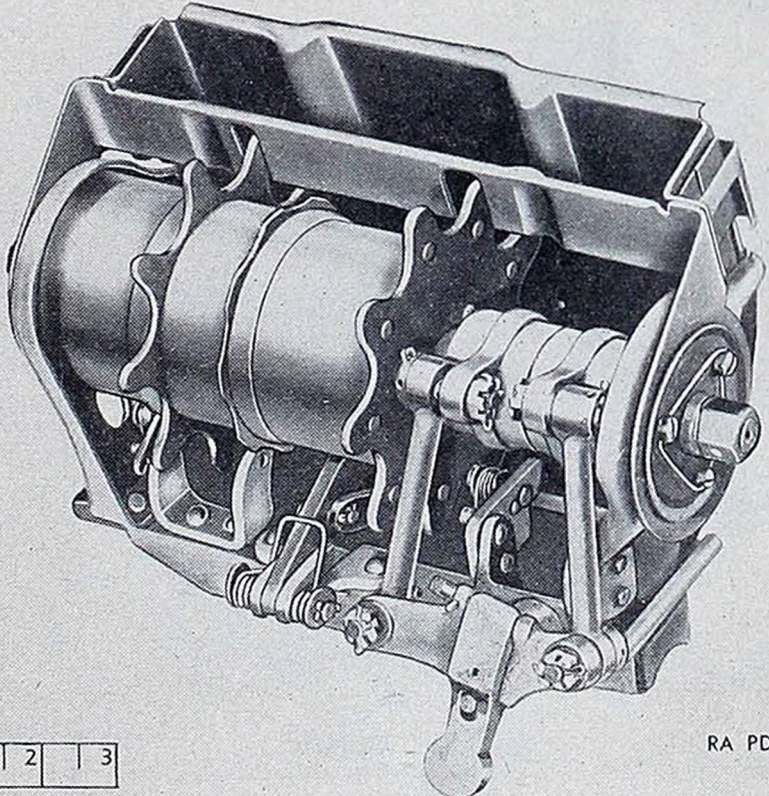

Figure 47. 20-mm feed mechanism AN-M2, left-hand—right-side view.



RA PD 171988

Figure 48. 20-mm feed mechanism AN-M2, right-hand—left-side view.



RA PD 171989

Figure 49. 20-mm feed mechanism AN-M2, right-hand—right-side view.

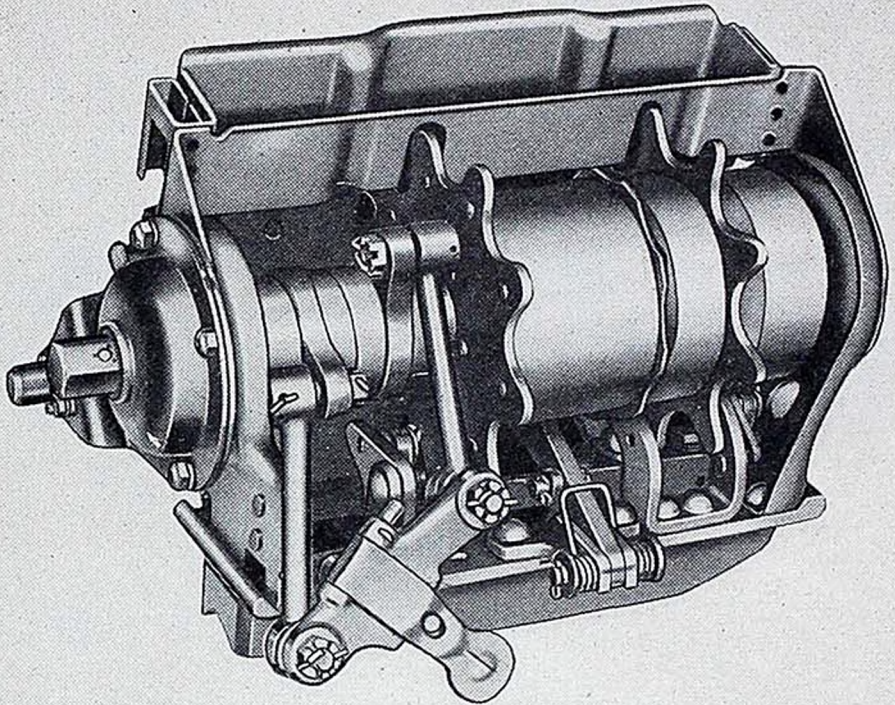

LH FEED MECHANISM

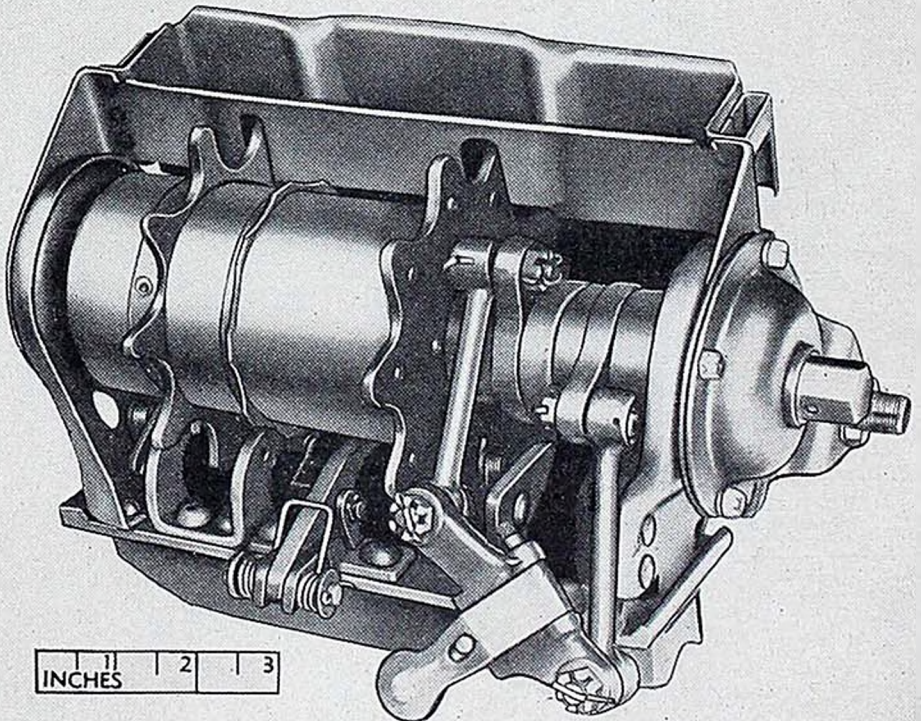

RH FEED MECHANISM

RA PD 196641

Figure 50. 20-mm feed mechanism M2E4, left-hand and right-hand.

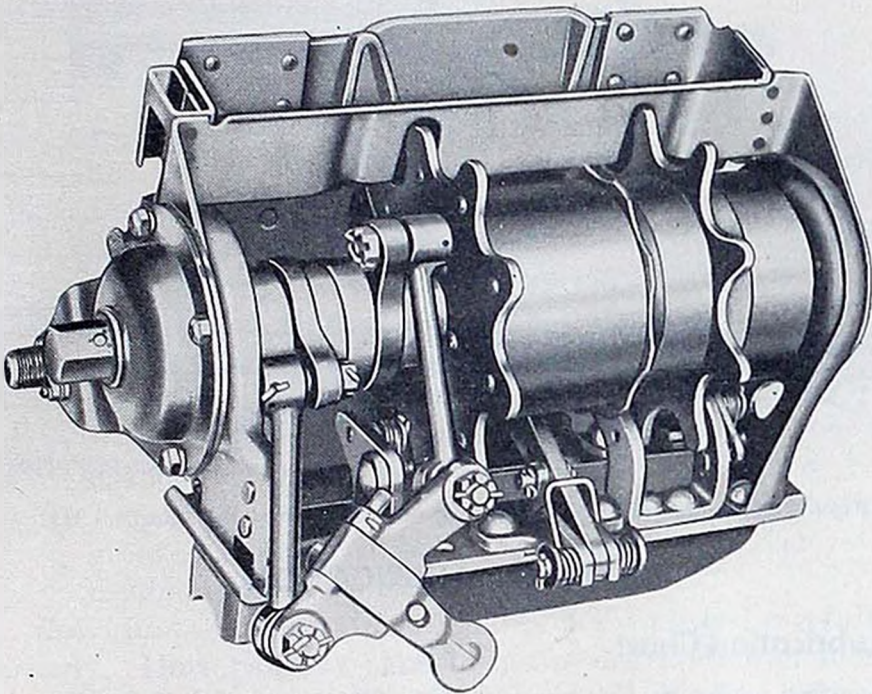

LH FEED MECHANISM

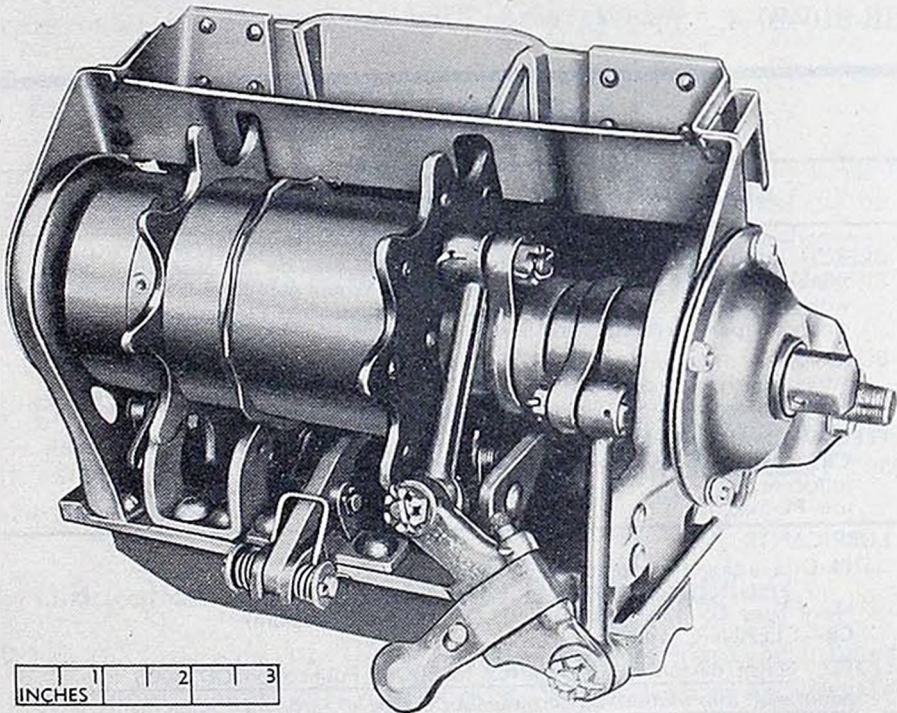

RH FEED MECHANISM

RA PD 196642

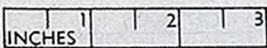

Figure 51. 20-mm feed mechanism M2E5, left-hand—right-side view.

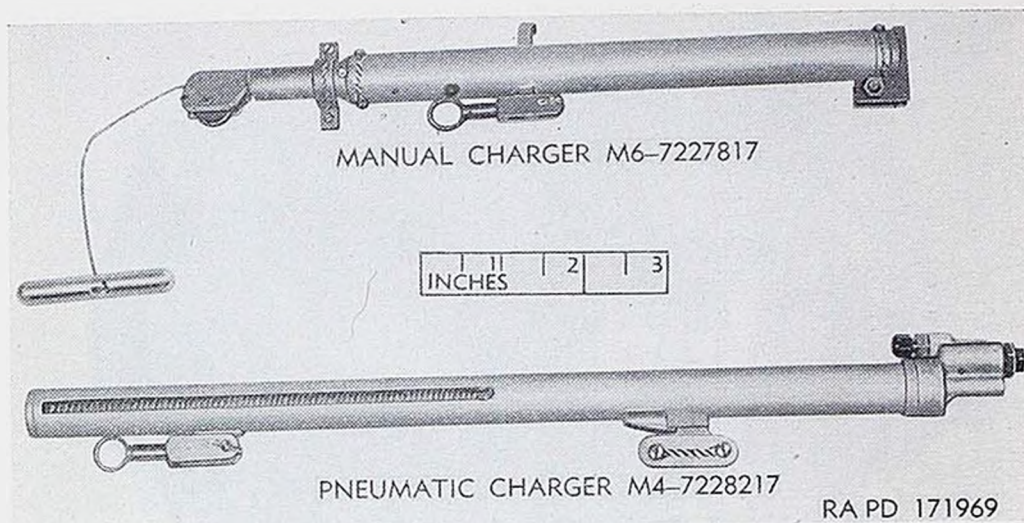

Figure 52. 20-mm manual charger M6 and pneumatic charger M4.

Section II. LUBRICATION

38. Lubrication Chart

The lubrication chart (fig. 53) prescribes cleaning and lubricating procedures as to locations, intervals, and proper materials for this materiel. A copy of the chart should be carried with the weapon at all times. The official lubrication order, when available, will be listed in SR 310-20-4.

LUBRICATION CHART	
GUN, AUTOMATIC, 20-mm, M24, M24A1, and M24E2	
BRECH MECHANISM	—Immediately after firing and on 3 consecutive days thereafter, clean with CR , and wipe dry. When gun is to be fired, lubricate with PL-special . When gun is not being fired, use PL-medium . Weekly clean all parts with CR and renew oil film.
BORE	—After firing and on 3 consecutive days thereafter, clean with CR . After fourth cleaning, dry, oil with PL-medium . When gun is not being fired, renew oil film weekly. Wipe clean before firing.
FEED MECHANISM	—Weekly, and after firing, remove from gun, clean with CR . Wipe exposed surfaces with cloth moistened with PL-special and lubricate moving parts sparingly with PL-special . For inactive period use PL-medium .
LUBRICANTS:	
	PL-OIL , lubricating, preservative
	or
	Navy Spec OS 1361 (PL-special); OS 1363 (PL-medium)
	CR —CLEANER, rifle bore
NOTE: <u>Naval personnel are referred to BuOrd Publication OD 3000 for additional information concerning lubrication of ordnance equipment.</u>	

Figure 53. Lubrication chart.

RA PD 203056

RESTRICTED—Security Information

39. General Lubrication Instructions

a. Service Intervals. Service intervals specified on the lubrication chart are for operation under moderate temperature, humidity, and atmospheric conditions. Reduce service intervals to compensate for abnormal or extreme conditions, such as high or low temperatures, prolonged periods of continued operation in sand or dust, immersion in water, or exposure to moisture. Any one of those operations or conditions may cause contamination and quickly destroy the protective qualities of the lubricants. Lubrication intervals may be extended during inactive periods commensurate with adequate preservation.

b. Cleaning Prior to Lubrication.

(1) Prior to lubrication, all guns should be cleaned by one of the methods outlined in paragraph 9 or 12.

(2) Extra care must be taken when cleaning notched surfaces, grooves, and internal holes to insure complete removal of all residue and sediment.

c. Lubrication. Lubrication should be accomplished carefully and sparingly. Move parts by hand to insure distribution of lubricant. Wipe off excess lubricant. Do not oil bore and chamber before firing because dangerous pressures may develop.

d. Reports. Report unsatisfactory performance of materiel or defects in the application or effect of prescribed lubricants and preserving materials in accordance with paragraph 2*b*.

40. Extreme-Cold Weather Lubrication

In temperatures below freezing, all moving parts must be kept absolutely free of moisture. At low temperatures, excess oil on the working parts will solidify to such an extent as to cause sluggish operation or even complete failure. Extreme cleanliness and the sparing application of oil are essential.

41. Extreme-Hot Weather Lubrication

In extremely high temperatures, lubricate more frequently because heat tends to dissipate the lubricant.

42. Lubrication Under Sandy and Dusty Conditions

When the gun is used in sandy and dusty areas, keep the lubrication to a minimum because oil collects dust, which acts as an abrasive on the working parts and surfaces and may foul the bore and chamber. Apply preservative lubricating oil (special) lightly to working parts.

43. Lubrication Under Extreme Moist or Salt-Atmosphere Conditions

a. Salt air is conducive to quick rusting as the salt has a tendency to emulsify the oil and destroy its rust-preventive qualities. When mounted in aircraft, guns should be kept lightly lubricated and inspected frequently.

b. When guns are dismounted, they should be thoroughly cleaned and lubricated with preservative lubricating oil (medium) if their use is not anticipated for a prolonged period of time. If preservative lubricating oil (special) is used, guns should be inspected daily.

Section III. PREVENTIVE MAINTENANCE SERVICES

44. General

Preventive maintenance services prescribed by Air Force regulations are a function of organizational maintenance units or armorers. These services consist generally of preflight, postflight, and major services performed by organizational maintenance personnel.

45. General Procedure

The general preventive maintenance procedures outlined in *a* through *g* below should be observed, in addition to that referred to in the schedules listed in paragraph 46.

a. The importance of a thorough knowledge of how to clean and lubricate the materiel cannot be overemphasized. The kind of attention given to this gun largely determines whether the gun will shoot accurately and function properly when needed.

b. Rust, grit, dirt, gummed oil, and water cause rapid deterioration of all parts of the materiel. Particular care should be taken to keep all bearing surfaces and exposed parts clean and properly lubricated. Wiping cloths, rifle-bore cleaner, dry-cleaning solvent or volatile mineral spirits, and lubricants are furnished for this purpose. Remove all traces of rust from surfaces with crocus cloth.

c. Tighten all loose parts, replace unserviceable parts, and see that lock washers, safety wire, cotter pins, and other locking devices are properly applied.

d. Do not dip or wash assemblies containing ring springs in dry-cleaning solvent or volatile mineral spirits. These units are lubricated by the manufacturer; if the special lubricant is diluted with dry-cleaning solvent or volatile mineral spirits, early failure of the unit will result.

e. Inspect spare parts, tools, and equipment for completeness, serviceability, and interchangeability. Missing items should be replaced;

RESTRICTED—Security Information

damaged items should be replaced or turned in for repair. Use only tools that are provided and see that they fit properly. Tools that do not fit may fail or cause damage to parts.

f. At least every 6 months, check to see whether all technical orders have been applied. Check AF Form 185 for completeness. A list of current technical orders is published in TO No. 00-1-1 and TO No. 00-1-2. If a technical order has not been applied, notify the local armament officer promptly. No alteration or modification is to be made except as authorized by official publications.

g. Each time the materiel is disassembled for cleaning or repair, carefully inspect all parts for cracks, excessive wear, rust, and other defects that might cause malfunction of the materiel. See paragraphs 58 through 62, for trouble shooting information; use this section for a guide during inspection. Thoroughly clean and properly lubricate all parts before assembly. Also, replace all springs that are broken, kinked, or fail to meet operational requirements.

46. Specific Procedures

a. Preflight or Before-Firing Inspection of Weapons in Aircraft.

- (1) Thoroughly clean the bore and chamber of all dirt, oil, and grease.
- (2) Wipe excess oil from moving surfaces with a clean wiping cloth, dipped in the proper oil and then wrung out.
- (3) Inspect ammunition for presence of wax coating on shell cases and for alinement of rounds in belt.
- (4) Remove covers from gun tubes or flash hidlers.
- (5) Check if charger is securely attached to the cradle assembly.
- (6) Check to assure that all electrical connections are tight and in proper location.
- (7) Check driving spring guide cap lock plate for damage and tightness on driving spring guide cap and on driving spring guide plunger assembly.
- (8) Check driving spring guide retainer for damage and tightness on rear buffer and driving spring guide.

b. Postflight Inspection of Test-Fired Weapons Not to Be Removed From Aircraft.

Caution: Remove ammunition from the weapon.

- (1) *Bore and chamber.* The following cleaning procedure is to be followed at the end of the day's firing. If no further firing is anticipated, the procedure is to be repeated on three consecutive days thereafter.

(a) Place two clean patches in the slot of the cleaning staff 5570631 (fig. 44), saturate the patches with rifle-bore

RESTRICTED—Security Information

cleaner, and move them back and forth through the tube several times. It is imperative that care be taken to avoid any possible damage to breechblock contact wire when cleaning rod is passed through the bore. If rust, rust spots, or foreign matter are not removed by the rifle-bore cleaner, attach bore brush 7225087 (fig. 44) to cleaning staff and run the brush through the tube several times. Make certain that the brush goes all the way through before reversing its direction. Allow a light coating of rifle-bore cleaner to remain in the bore between cleanings to prevent rust. Use muzzle cover 7237710 (fig. 44) or 7230224 to protect interior of tube from dirt and foreign matter.

- (b) After fourth cleaning following firing, if no firing is anticipated within the next 24 hours, place clean dry patches in the slot of the cleaning staff and thoroughly dry bore and chamber. With clean dry patches dipped in preservative lubricating oil (special) and then wrung out, apply a light film of oil to the bore and chamber by working the patches through the bore.

Note. Remove oil from and bore and chamber if matériel is to be fired.

(2) *Parts other than tube.*

- (a) With rifle-bore cleaner, thoroughly clean all surfaces, that have been exposed to powder gases.

Caution: Immersion of the recoil mechanism, rear buffer assembly, and the pneumatic charger in cleaning solution will damage these assemblies. Clean these assemblies with a cloth that has been dipped in cleaning solution and wrung out; then wipe them with a dry cloth.

- (b) Remove dirt and foreign matter from all other parts. Thoroughly dry all components and immediately apply a light coating of preservative lubricating oil (special). Handle parts with gloved hands, as the acid affect of perspiration of the hands accelerates rusting.

- (3) *Feed mechanism.* Check torque (par. 57g), unless the ammunition has been expended, allowing the drive spring to unwind. The torque reading should not change appreciably.

Note. The greatest number of malfunctions due to low torque occurs at or below 240 inch-pounds or 20 foot-pounds.

c. Preflight Inspection of Weapons in Shop Prior to Installation in Aircraft.

- (1) Check firing cable for cracks in the insulation; see if rubber insulation is pulled out from under the ferrule.

RESTRICTED—Security Information

- (2) Check driving spring guide spring for tension on guide. Plunger should be under tension when fully extended.
- (3) Check radius on top edge of breechblock locking key; remove sharp edge and burrs.
- (4) Test extractor spring for deformation and set.
- (5) Check breechblock slide key to see that insulating button is in place.
- (6) Inspect firing pin contact for deformation and defective insulation.
- (7) Check breechblock lock for cracks and marred surfaces.
- (8) Test spring tension on breechblock bolt retainers. If springs are obviously weak or broken, replace breechblock bolt assembly (if replacement bolt assembly is available) and request instructions for the disposition of bolt assembly from the appropriate Air Force installation. If replacement bolt assembly is not available, the retainers and springs will be replaced by the A and E maintenance squadron.
- (9) Check feed mechanism for brass tacking on underside of stripper cams and for burrs in link ejection passageway. Check holding pawls, etc., for lubrication. Check heater cartridge with an ammeter; reading should be 0.478 amps at 115 volts.
- (10) Check stripping clearance by properly positioning two dummy rounds and links (single-loop feed for RH mechanism and double-loop feed for LH mechanism) on star wheel and easing forward by hand until stripper cams engage ears of the links; cams should not obstruct round or ears.

47. Schedule of Preventive Maintenance

a. Before Firing or Preflight. When firing the gun or when a flight is anticipated, perform the preventive maintenance operations indicated in table II.

b. After Firing or Postflight. After firing of the gun and after each flight, perform the preventive maintenance operations indicated in table II.

Section IV. CYCLIC FUNCTIONING OF WEAPON

48. General

The cyclic functioning of the weapon as a whole, from the firing of one round to the firing of the next, is described in paragraphs 49 through 55. For the purpose of explanation, the cyclic functioning is divided into the following actions:

Recoil action (par. 49).

RESTRICTED—Security Information

Table II. Before Firing or Preflight and After Firing or Postflight Preventive Maintenance Schedule

Item	Preventive maintenance	Detailed instructions
	<i>Before firing or preflight</i>	
Gun as a unit.....	Check for proper lubrication and cleanliness.	Par. 38.
Magazine slide.....	Check alinement of engraved lines on slide and receiver.	Par. 21b(9)(f).
Magazine slide anchor.	See that the anchor locking nuts are tight.	Par. 21b(9)(f).
Gas cylinder group..	Check gas cylinder vent plug for looseness (M24 and M24E2).	Par. 77a.
Electric firing circuit.	Look for breaks in wires and insulation and check the electrical firing circuit.	Par. 17.
Chargers.....	Check operation.....	Actuate and note operation. If breechblock is retracted, mechanism may be considered serviceable.
Do.....	Lubricate.....	Par. 85a or 87a.
Feed mechanism.....	do.....	Par. 89a and b.
	<i>After firing or postflight</i>	
Malfunctions or stoppages.	Check for type.....	Table III (par. 6).
Gun as a unit.....	Unload and record the number of rounds fired.	Par. 2.
Bore, chamber, and all working parts.	Inspect, clean, and oil.....	Par. 38.
	Examine firing pin contacts.....	Par. 72.
	Check spring tension of breechblock bolt retainer springs.	Notify field maintenance personnel.
	Inspect breechblock lock for cracks or marred surfaces.	Par. 72.
	Inspect driving spring guide assembly.	Par. 67.
Gas cylinder group..	Clean and inspect.....	Remove any carbon deposits (M24 and M24E2). Make certain that gas ports in tube and in vent plug are open (M24 and M24E2).
Chargers.....	Check operation.....	Actuate and note operation. If breechblock is retracted, mechanism may be considered serviceable.
Feed mechanism.....	Clean and lubricate.....	Par. 89a and b.

RESTRICTED—Security Information

- Breechblock unlocking action (par. 50).
- Extraction and ejection (par. 53).
- Rear buffer and driving spring action (par. 51).
- Feeding and chambering (par. 52).
- Breechblock locking action (par. 54).
- Firing action (par. 55).

49. Recoil Action

(fig. 54)

a. When a round is fired, the pressure of the propellant gases in the tube forces the gun to recoil to the rear for about 1 inch. As the gun recoils, the recoil spring front seat and the gun move toward the rear and compress the recoil spring. Since the spring rate of the ring spring in the recoil housing assembly is greater than the spring rate of the helical recoil spring, the helical recoil spring alone is compressed by the rearward movement of the gun for the first phase of recoil until the gun has recoiled approximately seven-eighths of an inch rearward. At this point, the rear end of the recoil spring front seat contacts the front end of the recoil spring rear seat, thus stopping the compression of the recoil spring. The recoil spring rear seat compresses the ring spring of the recoil housing assembly, which absorbs the remaining shock of recoil. At maximum recoil, both springs recover and return the gun into battery.

b. The ring spring of the recoil housing assembly functions as a counter-recoil buffer if the gun travels past its in-battery position. For this function, the ring springs are compressed in the same manner as during recoil movement of the gun, but the action of the parts is reversed.

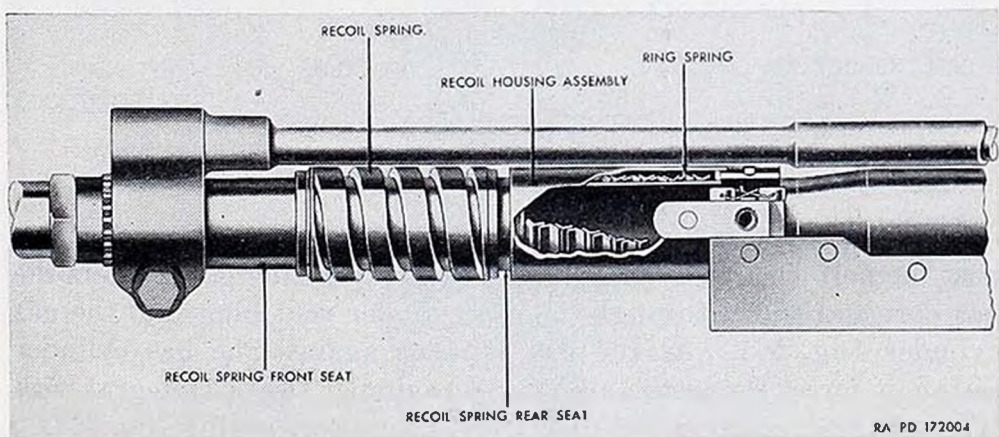

Figure 54. Action of recoil spring and ring springs.

50. Breechblock Unlocking Action

a. The breechblock is unlocked by the action of the gas cylinder sleeve group. At the moment of firing, the breechblock is held in its forward position by the action of the breechblock lock. The lock engages the breechblock at point (A, fig. 55) and bears against surface (B, fig. 55) of the breechblock key. The breechblock slide engages the lock at point (C, fig. 55), thus preventing the lock from being forced upward prematurely.

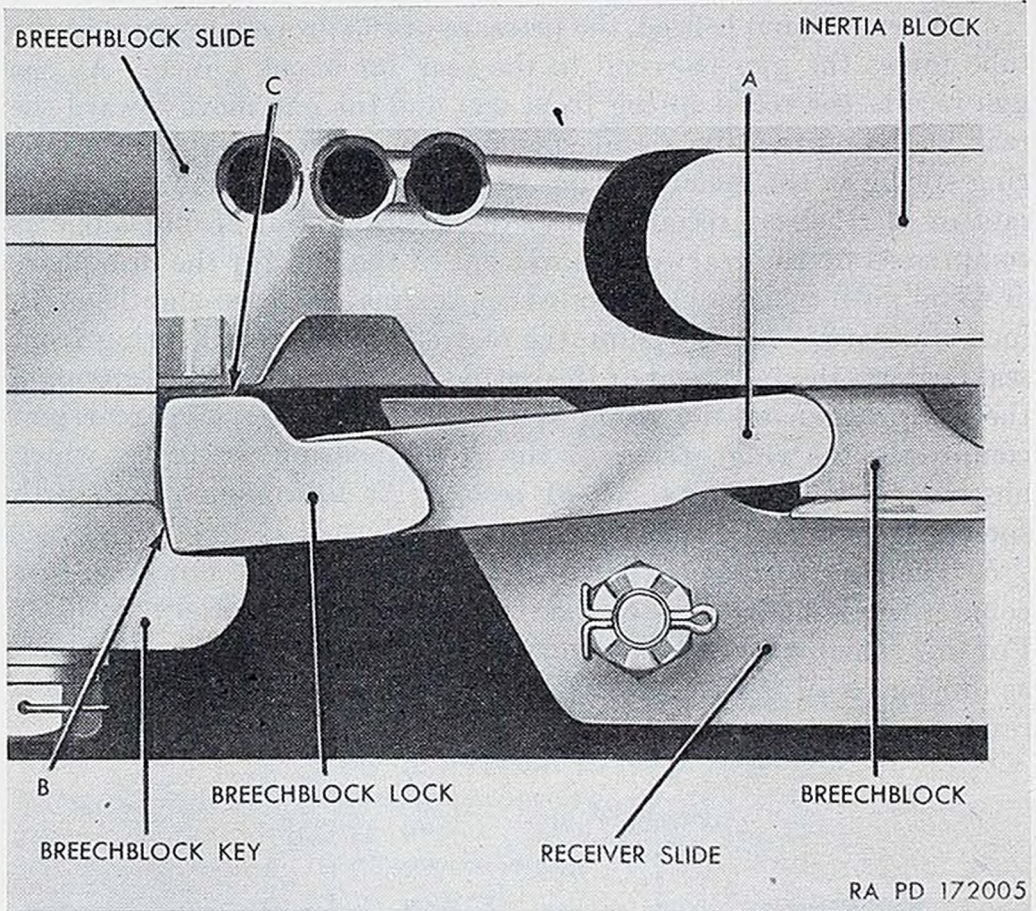
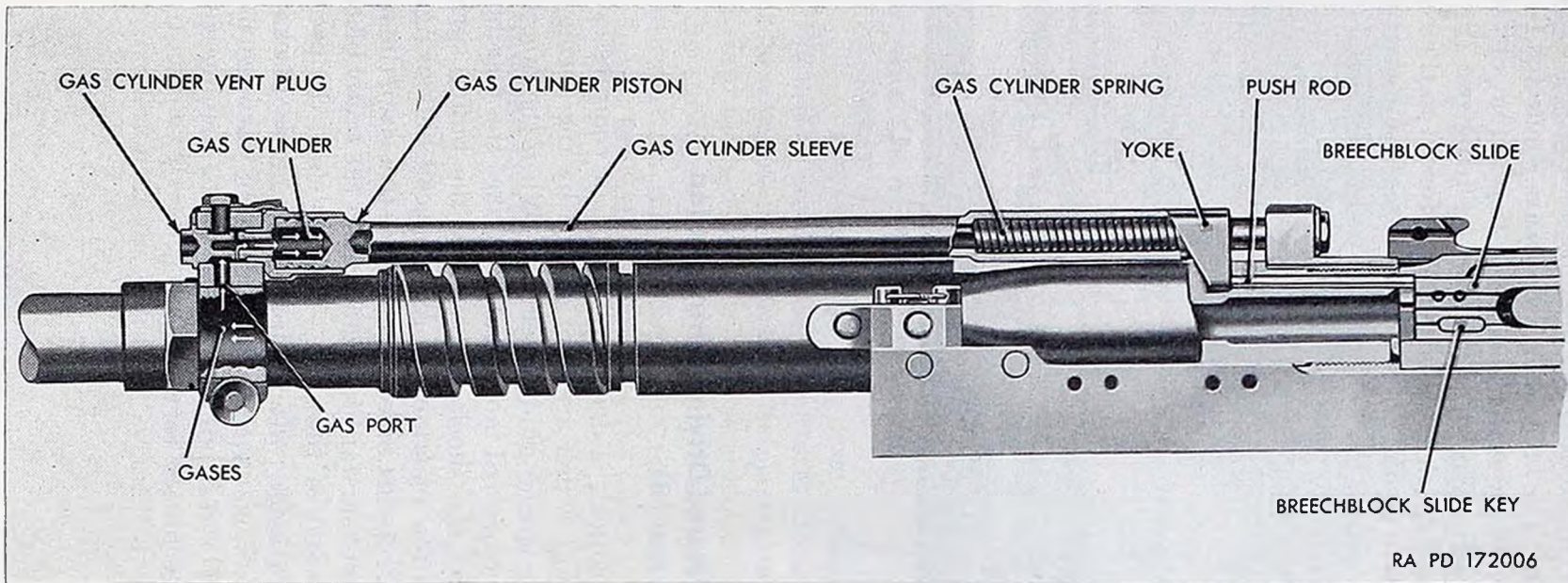

Figure 55. Breechblock lock in locked position at moment of firing.

b. As the round is fired, the projectile is driven forward in the tube, past the port (fig. 56). A portion of the expanding gases enters the gas port and passes through the gas cylinder vent plug into the gas cylinder (fig. 56). As the gas expands against the gas cylinder piston, it forces the piston and the gas cylinder sleeve (integral with it) to the rear, compressing the gas cylinder sleeve spring (fig. 56).

c. As the sleeve is forced to the rear, the yoke on the sleeve contacts the two push rods, which, in turn, move the breechblock slides (fig. 57)

RESTRICTED



RESTRICTED—Security Information

Figure 56. Action of gas cylinder sleeve group for unlocking the breech.

RESTRICTED—Security Information

rearward, allowing residual gas pressure acting on the bolt to unlock the breechblock. The breechblock slides are connected to the breechblock slide key, which engages a slot in the bottom of the firing pin guide, and the latter, in turn, retracts the firing pin (fig. 57). The moment the breechblock is unlocked, it is forced to the rear by blow-back action, with a resultant drop of gas pressure in the tube. As the gas pressure drops, the gas cylinder sleeve spring expands and returns the sleeve and piston to the original position.

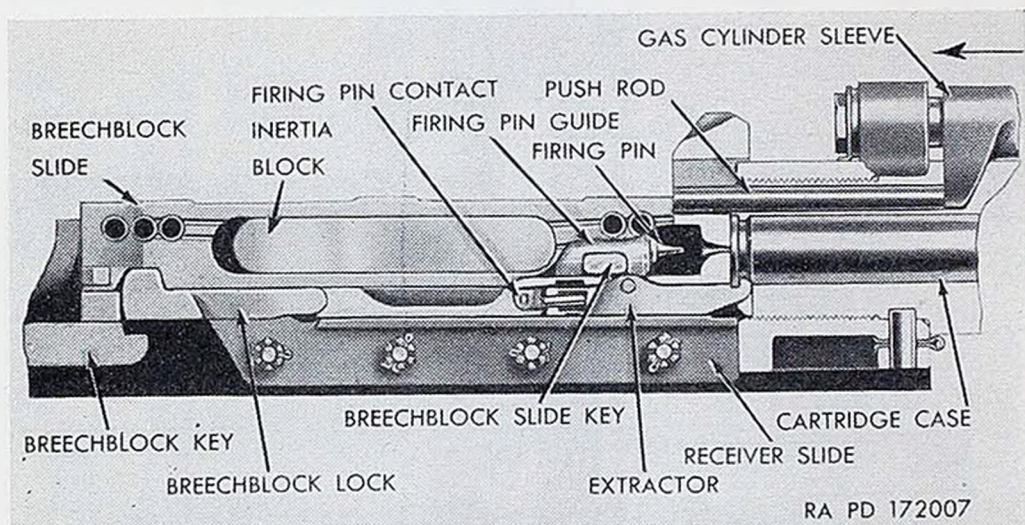

Figure 57. Unlocking of breechblock and retraction of firing pin.

51. Rear Buffer and Driving Spring Action

(figs. 58 and 59)

As the breechblock is driven rearward, it compresses the driving spring or springs which are kept in line by the spring-loaded telescoping driving spring guide assembly. When the breechblock nears the end of the rearward movement, it strikes the rear buffer washer, which transmits the shock of recoil to the buffer springs. These springs absorb the remaining force of recoil and bring the breechblock to a stop. As the breechblock comes to a stop, the inertia blocks continue to move rearward in their slots in the breechblock slide until they reach the end of the slots. By this time, the breechblock has started forward again; after impact, the inertia blocks bounce forward and then move to the rear during the forward motion of the breechblock. The rear buffer springs and the driving spring expand, forcing the breechblock forward.

RESTRICTED—Security Information

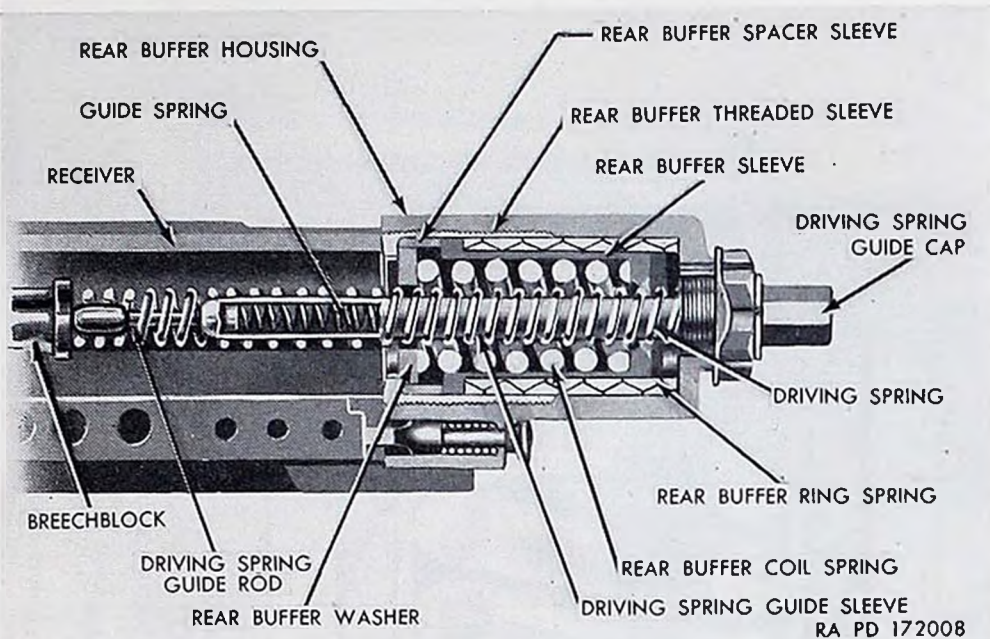

Figure 58. Rear buffer and driving spring guide group—cross-sectional view.

52. Feeding and Chambering

(figs. 60 and 61)

When the recoiling breechblock is sufficiently far to the rear to clear the feed mechanism, a new round is forced downward into the mouth of the feed mechanism. As the breechblock is forced forward by the driving spring or springs, it engages the new cartridge that has been positioned in the mouth of the feed mechanism. As the cartridge is forced forward, it drops into the recess in the bolt, where it is gripped by the lip of the extractor as it enters the chamber.

53. Extraction and Ejection

(fig. 62)

When the breechblock assembly is forced to the rear, the empty cartridge case, which has been forcing the bolt back by blow-back action, is contacted on the upper edge by the two prongs of the ejector. The ejector causes the cartridge case to pivot about and force downward the forward end of the extractor. The cartridge case leaves the lip of the extractor and moves through an opening in the bottom of the receiver, thus completing the ejection action. When the cartridge case frees itself from the extractor, the extractor is returned to its normal position by the action of the extractor spring. The bolt assembly

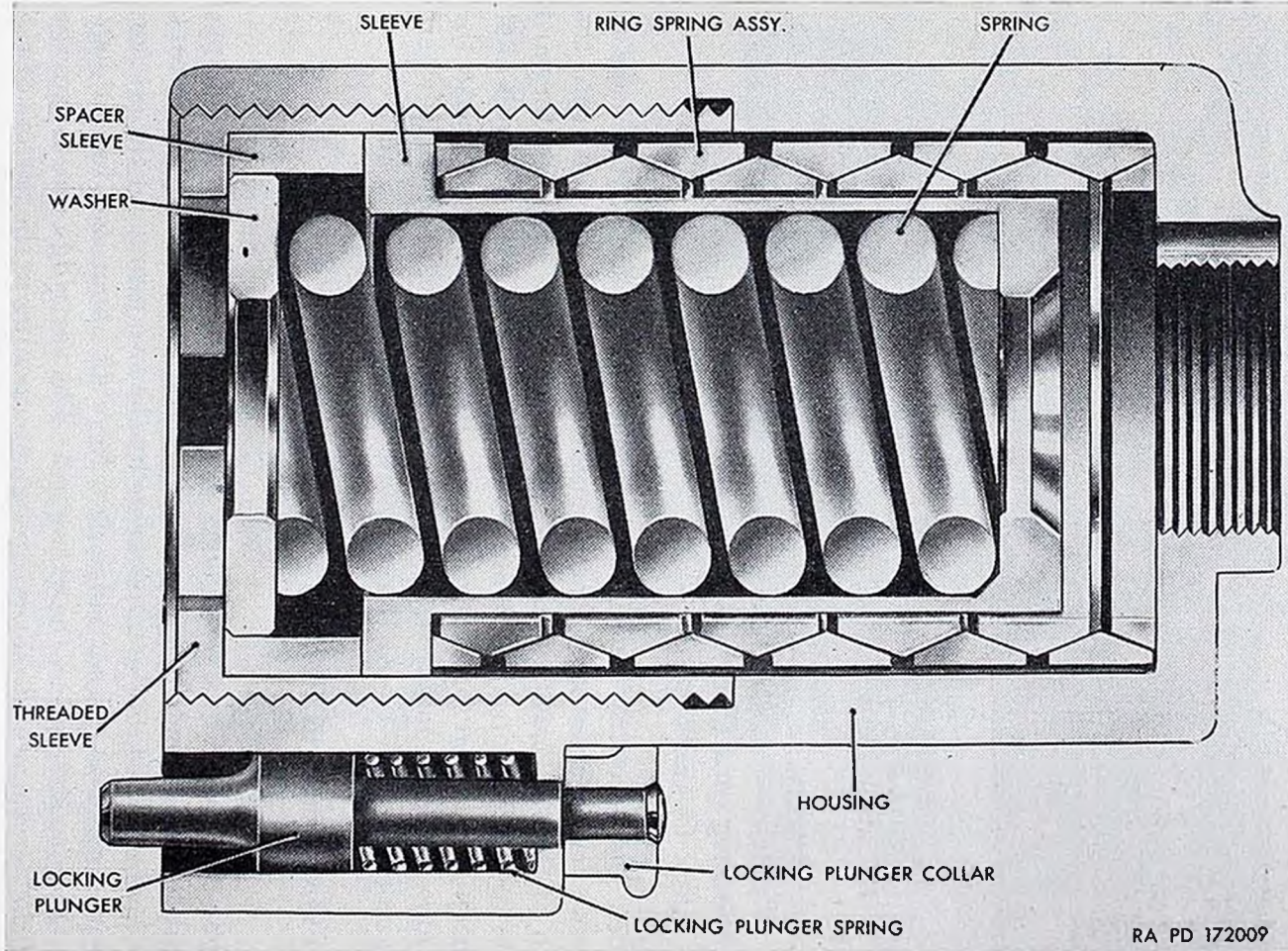

Figure 59. Rear buffer assembly—cross-sectional view.

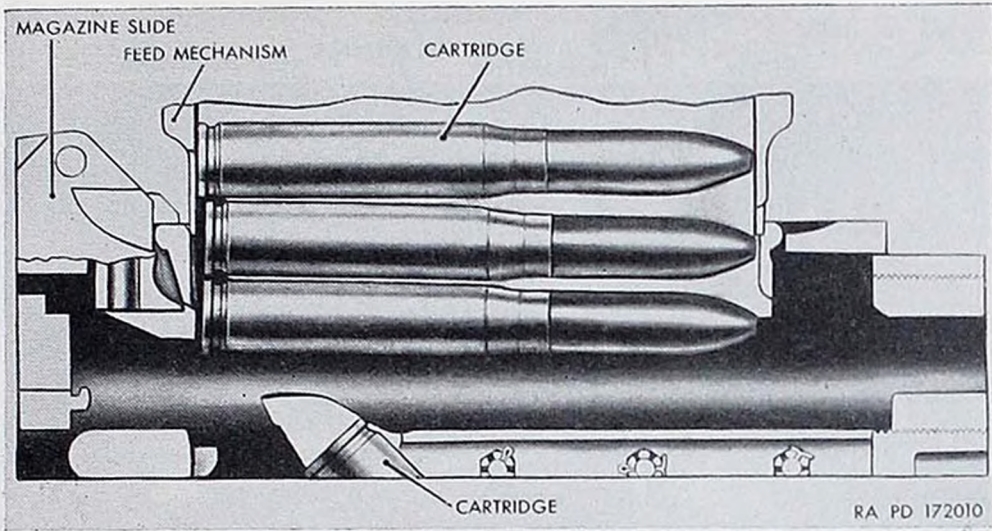

Figure 60. New round being forced downward into mouth of feed mechanism.

of the guns M24A1 and M24E2 has bolt retainers (fig. 5) to make ejection of misfired rounds more positive. These retainers stabilize the case or round against vibration of the lip of the extractor. The retainers are also helpful when guns are mounted in position other than with the ejection opening downward.

54. Breechblock Locking Action

As the breechblock reaches the end of its forward motion, it seats against the end of the tube and receiver, closing the chamber. The momentum of the slides and the action of the slide springs cause the slides to continue to move forward and cam the breechblock down

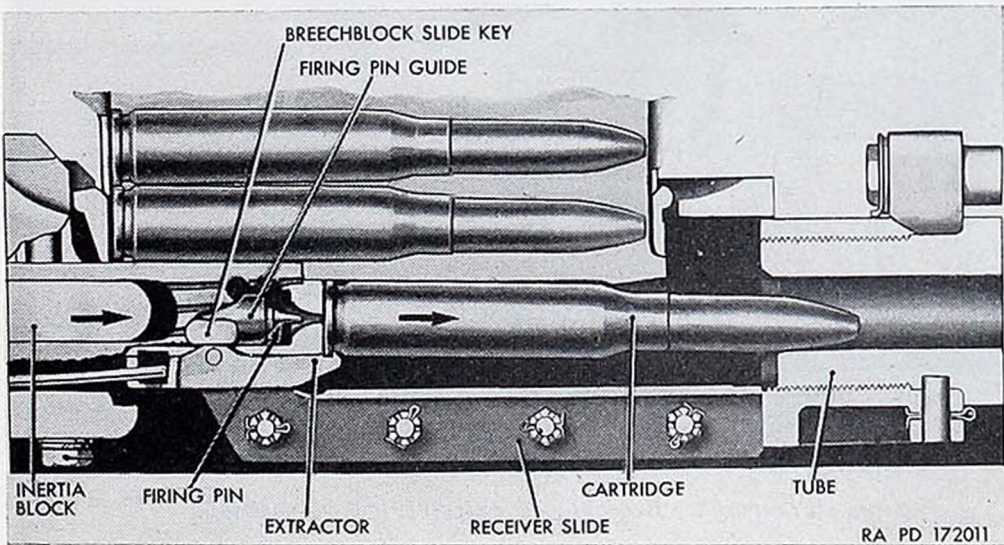

Figure 61. Ramming of round.

P12NAX

RESTRICTED—Security Information

**DEPARTMENT OF THE ARMY
TECHNICAL MANUAL**

TM 9-2006

**DEPARTMENT OF THE AIR
FORCE TECHNICAL ORDER**

TO 39A-5BA-4

**20-mm
AUTOMATIC GUNS
M24, M24A1
AND
M24E2**

*DEPARTMENTS OF THE ARMY AND THE AIR FORCE
APRIL 1953*

RESTRICTED

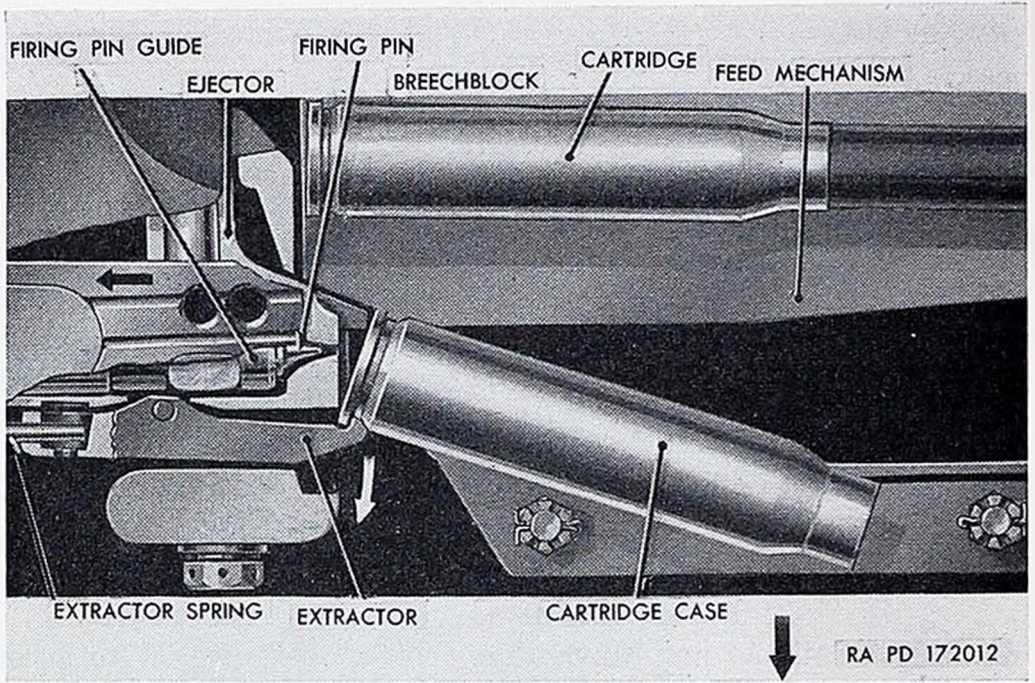

Figure 62. Ejection of cartridge case.

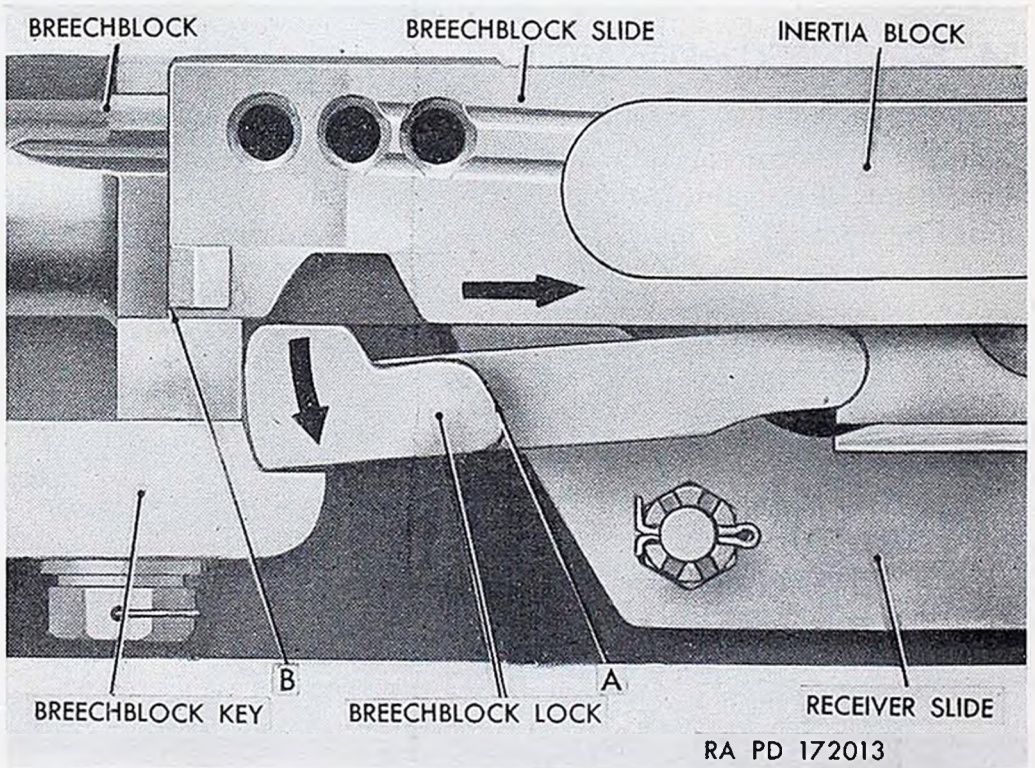

Figure 63. Breechblock entering locked position.

RESTRICTED—Security Information

into its locked position. At the same time, projecting cams (A, fig. 63) of the lock are engaged by cam surfaces on the receiver slides, which (together with the action of the cams on the bevel of the lock) cam the lock downward. The lock seats against the breechblock key and is locked in its downward position by the lower surface of the breechblock slides (B, fig. 63), which move over the rear end of the lock.

55. Firing Action

(fig. 64)

As the slides reach the end of their forward motion, the firing pin guide is carried forward by the slide key, allowing the firing pin spring to force the firing pin into contact with the electric primer. The current then passes through the cable, receiver contact, breechblock contact, and firing pin and through the firing pin to the primer, to fire the round. When the slides reach the end of their forward motion, the inertia blocks continue to move forward for a short distance and strike against the forward end of the slot, thereby counteracting any tendency to rebound that the slides might have. The circuit to the primer is broken when the slides move approximately one-fourth inch rearward and withdraw the firing pin from contact with the primer. Further motion of the slides unlocks the breech-

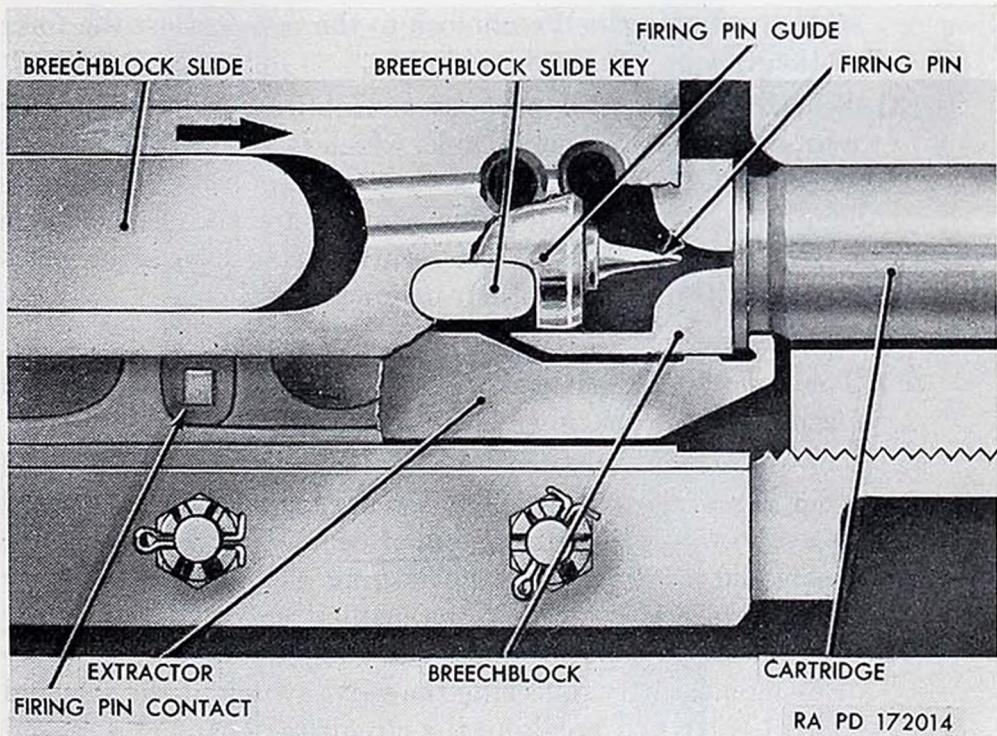

Figure 64. Firing pin moving to fire round.

block, permitting it to recoil. This action causes the circuit to the firing pin to be broken by the motion of the firing pin contact away from the breechblock contact and constitutes an additional safety feature.

Section V. FUNCTIONING OF CHARGES AND FEED MECHANISMS

56. Chargers

a. Manual Charger M6 (fig. 65).

- (1) The 20-mm manual charger M6 is a device for charging the 20-mm automatic guns by hand. Charging is accomplished by pulling the charger cable (fig. 65) to move the breechblock to the rear and then allowing it to return by spring action.
- (2) One end of the charger cable is fixed in position to the rear end plug of the charger and the other end passes through a latch pulley in the plunger assembly and out of the charger over a swivel sheave. Therefore, as the cable is pulled to the rear, it draws the plunger assembly to the rear against the force of the return spring. As the plunger assembly is forced to the rear, it contacts the lug on the breechblock slide and forces the breechblock to the rear against the force of the driving spring or springs.
- (3) When the slide and plunger assemblies are pulled to the rear, the end of the catch cable, which is fixed to the plunger assembly, also moves and, as a result, the return spring is compressed. When the gun is charged and the charger cable is released, the force of the return spring causes the operating parts to return to their original positions.

b. Pneumatic Charger M4 (fig. 66).

- (1) The 20-mm pneumatic charger M4 is an air or gas-powered mechanism for charging the 20-mm automatic guns.
- (2) The charger is activated by compressed air or gas supplied from a storage cylinder. The charger action is initiated by a two-way manually operated control valve (fig. 42) or a solenoid control valve. Charging is brought about by moving the valve lever of the manual valve and returning it to its original position after not less than 1-second delay or by momentarily squeezing the valve switch of the solenoid control valve and breaking the circuit by means of a second switch.

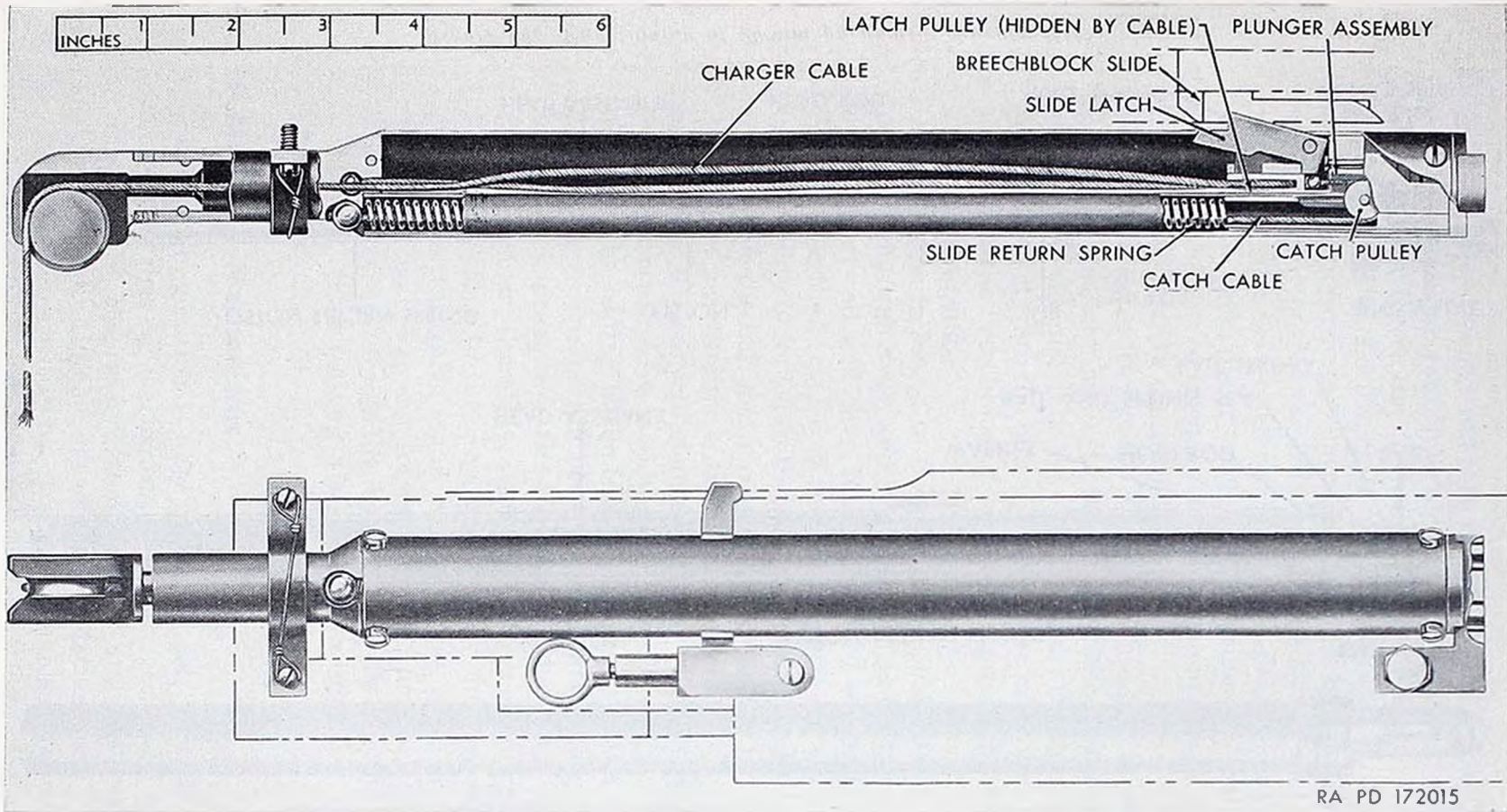

RESTRICTED

RA PD 172015

Figure 65. Functioning of 20-mm manual charger M6.

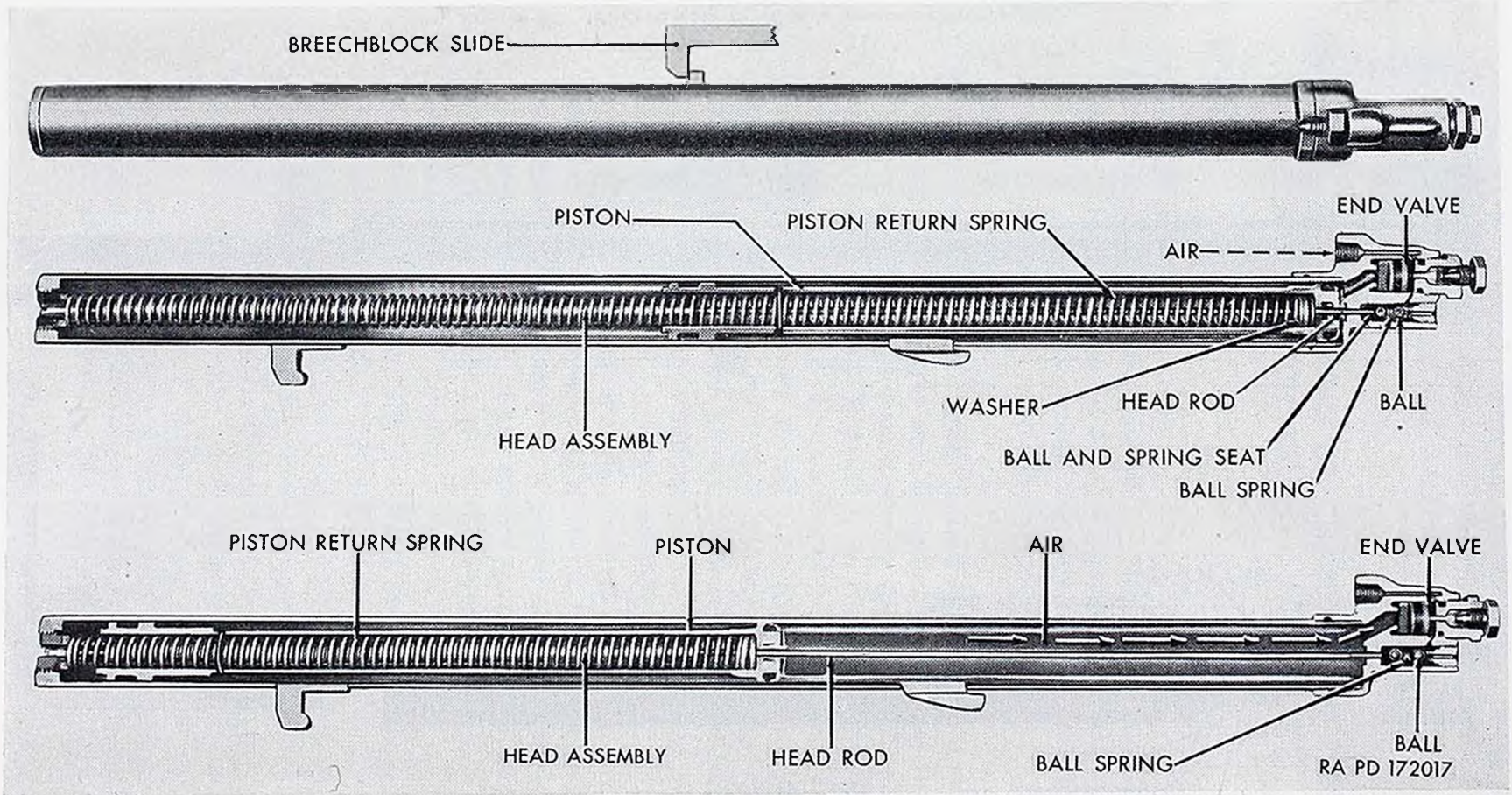

Figure 66. Functioning of 20-mm pneumatic charger M4.

RESTRICTED—Security Information

- (3) As the valve is opened and then closed, the compressed air on gas passes through the connector into the cylinder end assembly, where it forces the end valve against the inclined duct leading into the charger cylinder and closes the duct. The air, in the meantime, continues into the ball and spring seat, where it pushes the ball against the spring and enters the seat. The rear opening from the seat is always kept open by the pressure of the head rod against the ball, thus allowing the air to escape from the seat and pass around the head rod against the piston head.
- (4) As the air expands against the piston head, it forces the piston to the rear against the force of the piston return spring. As the piston is forced to the rear, the driving lug, which is attached to the piston, engages the breechblock slide and moves the breechblock to the rear against the force of the driving spring.
- (5) As the piston is forced to the rear, the inside bottom of the piston pushes the brass and steel washers against the flange of the head rod and thus forces the head assembly to the rear against the pressure of the head return spring. As the head assembly is forced to the rear, it enables the ball spring to act upon the ball and close the rear opening in the seat. This action prevents the entry into the cylinder of any more air than is necessary to charge the gun. When the storage cylinder control valve is closed, the supply of air is cut off and the line leading to the charger is opened to the outside, permitting escape of air between valve and charger, thus lowering the pressure in the front end of the valve. The air in the cylinder, therefore, passes up into the inclined duct, forces the valve to the rear, and escapes through two side openings in the valve seat. As the air escapes, the return spring forces the piston forward into its original position. The head rod now forces the rear outlet of the ball and spring seat open, thus making the charger ready for another operation cycle.

57. 20-MM Feed Mechanisms

a. As a belt of ammunition is drawn into the feed mechanism by the rotation of the driving mechanism, the rear star wheel engages the cartridge case at the rear of the belt link and the front star wheel engages the projectile just ahead of the rotating band.

b. As the belt rotates with the driving mechanism, the stripper cams (figs. 67 and 68) wedge between each cartridge case and the

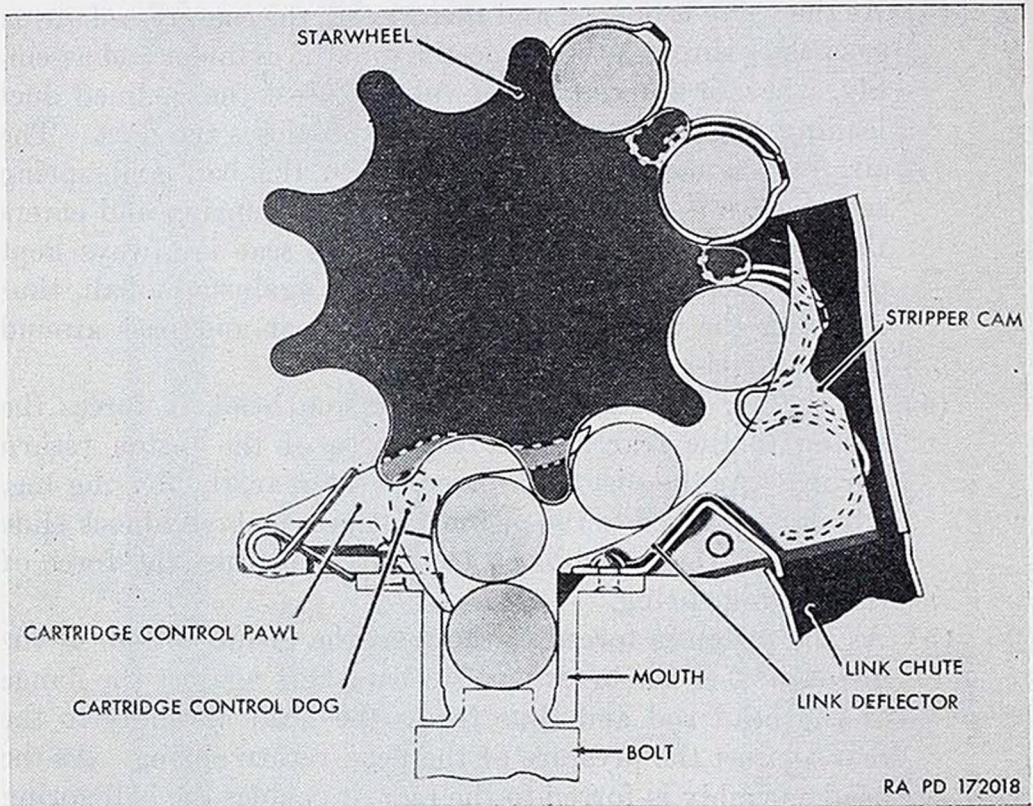

Figure 67. Stripper cam action in single-loop feed.

ears of the belt links and thus strip the links from the cartridges. If the empty single loop leads the belt, the first single loop is guided into the link chute by the link deflector, while the double loop (with the single loop between it) is being cammed from the round, as shown in figure 67. If the filled double loop leads the belt (left-hand mechanisms M2E4 and M2E5), the first double loop is cammed from the round and directed by the link deflector into the link chute, while the next double loop (with the single loop between it) is cammed from the round by the stripper cams, as shown in figure 68. The link is ejected from the feed mechanism through the link chute adapter. After the links have been stripped from them, the rounds are carried on by the star wheel until they are in line with the mouth. At this point, they are guided into the mouth by the front and rear cartridge guides (fig. 69), where they contact the spring-operated cartridge holding front and rear cams (fig. 70) and force them aside. The cams prevent the rounds from re-entering the feed mechanism after they have been forced into position in the mouth of the feed mechanism, as shown in figures 71 and 72.

c. The round is positioned in the bottom of the mouth at an angle of 3° and 20 minutes. The round is held in this position by the force exerted by the star wheels through the round that follows. This

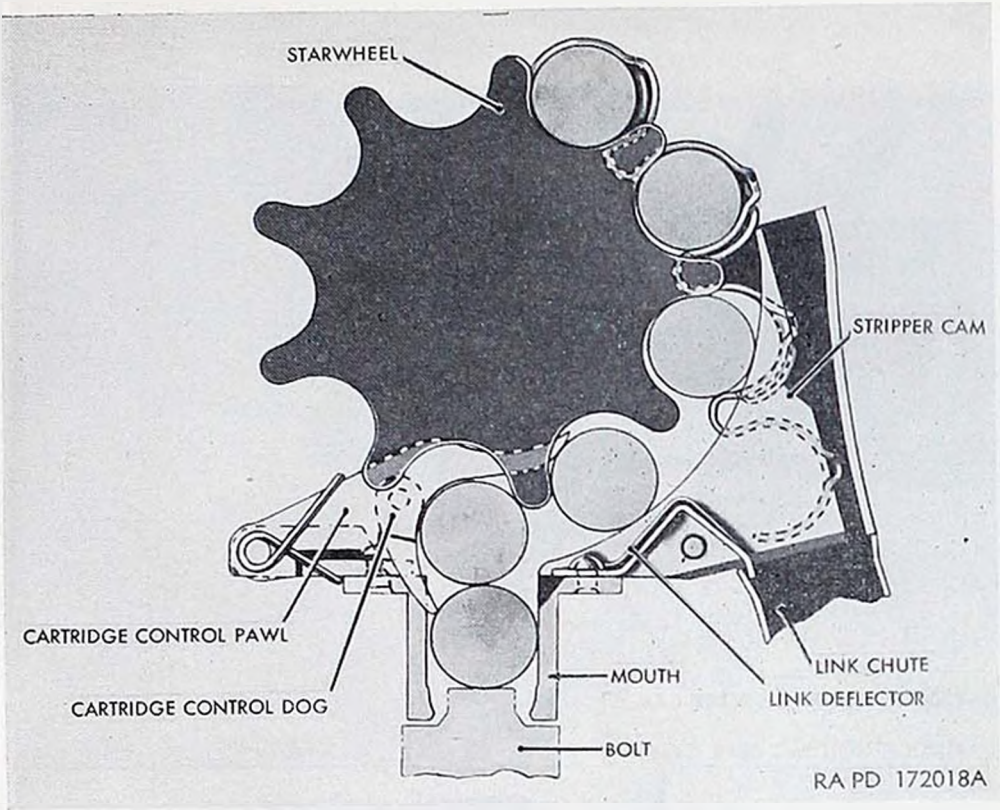

Figure 68. Stripper cam action in double-loop feed.

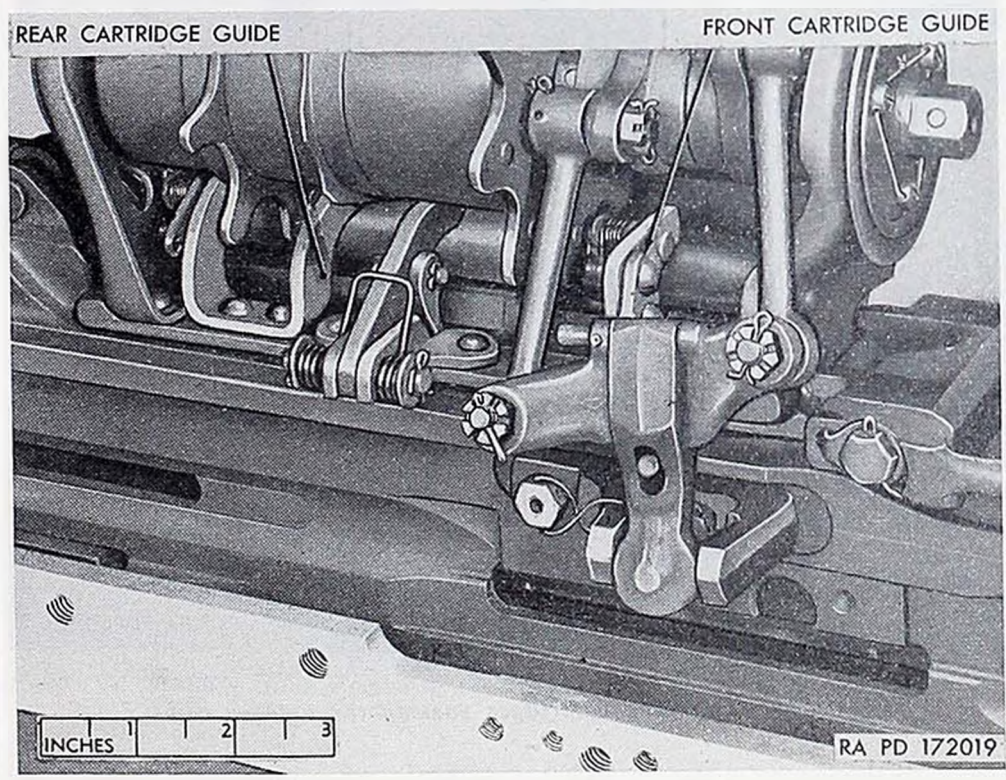

Figure 69. Action of cartridge guides.

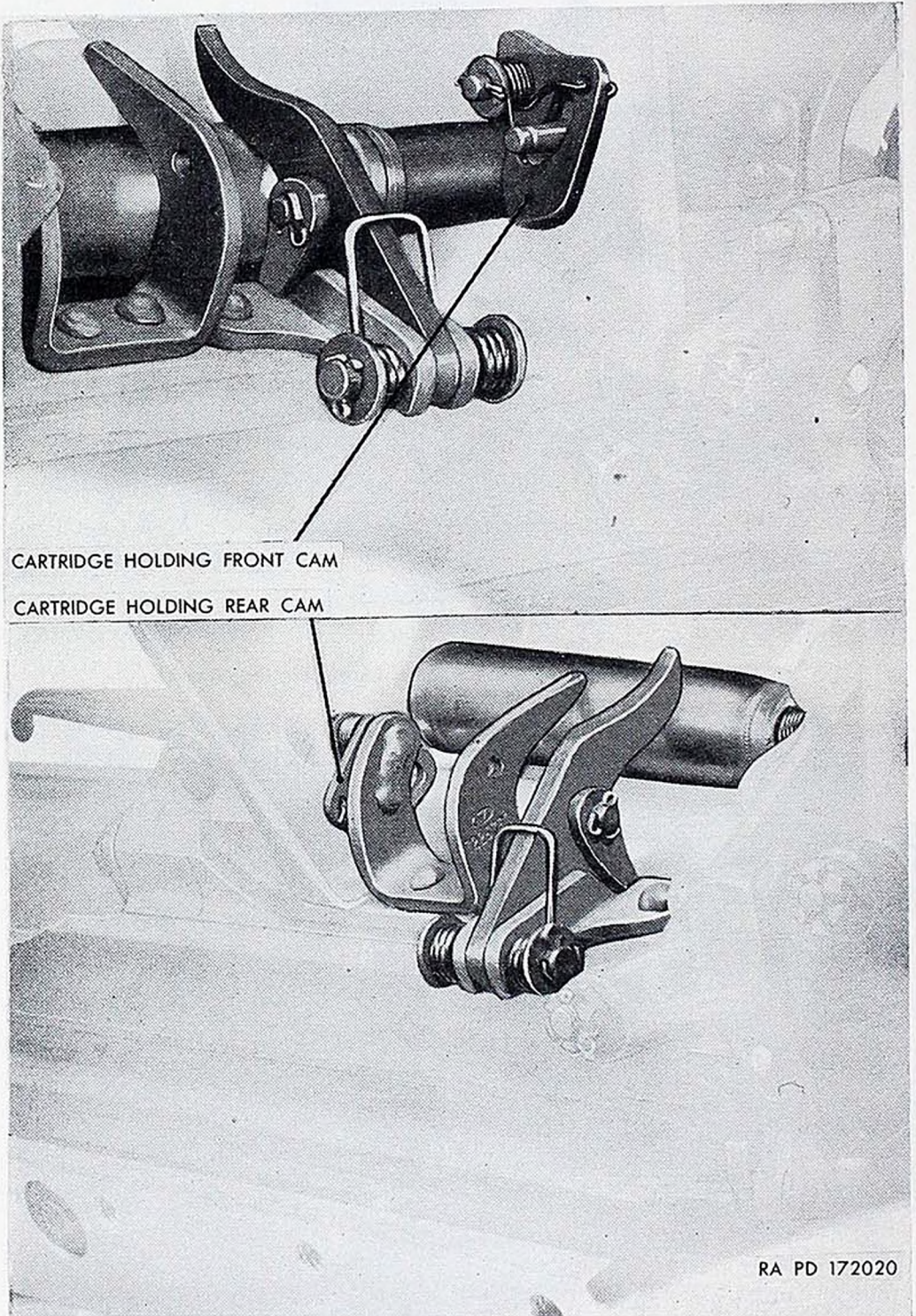

Figure 70. Incoming cartridges passing the holding cams.

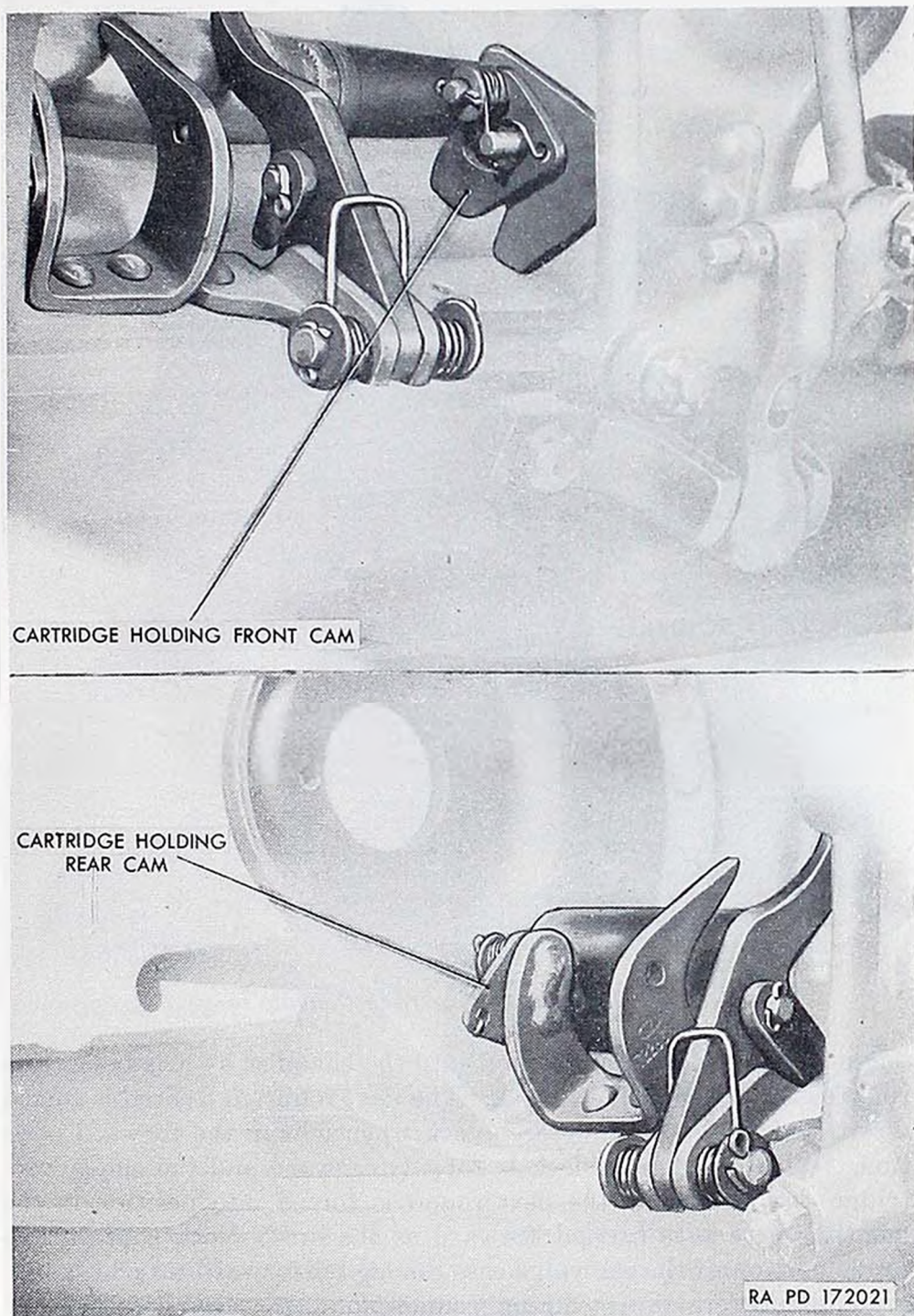
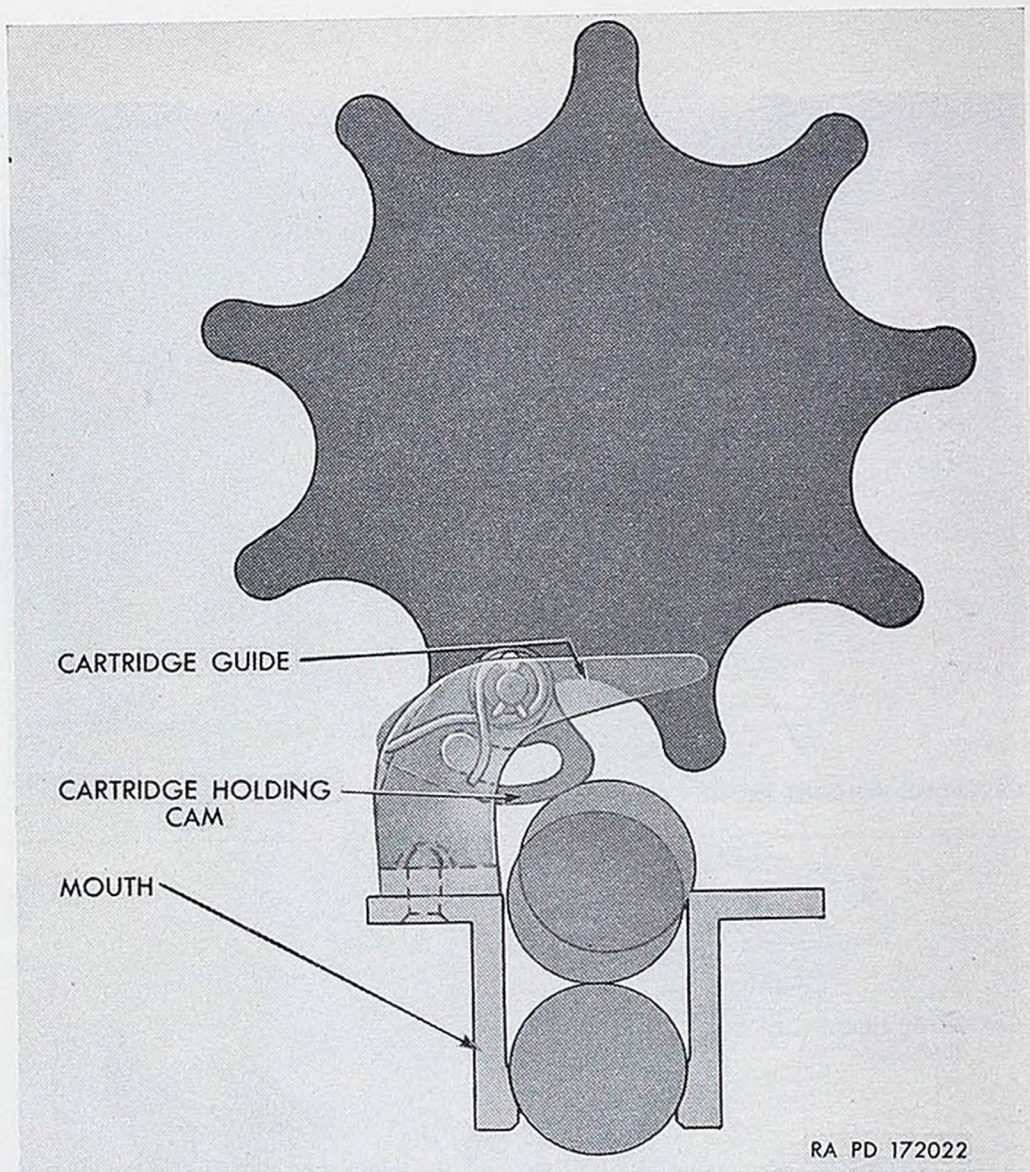

Figure 71. Holding cams preventing cartridges from re-entering feed mechanism.



RA PD 172022

Figure 72. Action of cartridge holding cam.

angle properly directs the round into the chamber as it is being carried forward by the breechblock. The next round to be fired is forced downward on top of the breechblock when it is in the forward position. When the breechblock is forced rearward and the empty cartridge case is ejected, the next round is forced into position in the mouth, where it is carried forward as the breechblock contacts the lower portion of the cartridge case during its forward travel.

d. Just before the incoming rounds enter the feed mouth, they contact the lower side of the spring-loaded cartridge control pawl, raising it slightly. This action lifts the cartridge holding dog, allowing the cartridge to enter the mouth (fig. 73). When the last round has passed under the control pawl and entered the mouth

RESTRICTED—Security Information

of the feed, the control-pawl spring forces the control pawl downward so that the holding dog prevents the last round from dropping all the way down into the mouth of the feed mechanism. If the last round should drop into the path of the breechblock, it would cause the gun to jam. The last round in the belt is held in such a position, by the holding dog, that the breechblock cannot contact it and jam the gun as it closes on the empty chamber. This round is also so

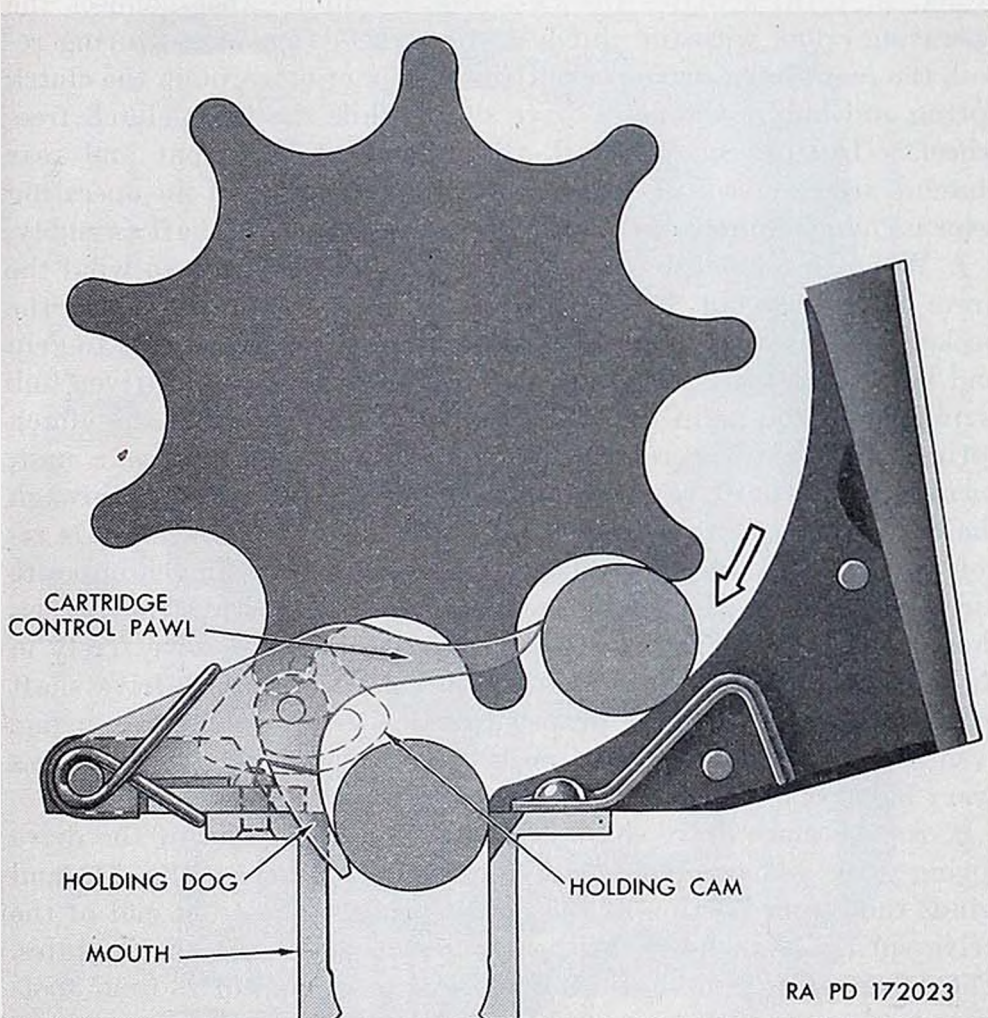

Figure 73. Action of cartridge control pawl and holding dog.

positioned that it clears the star wheels, permitting them to spin and automatically unwind the drive spring when the last two rounds have entered the mouth. The last round being held by the holding dog is released and forced into the feeding position in the mouth by the action of the first round of a new belt on the cartridge control pawl and dog. When the last round leaves the star wheels and enters the feed mouth, the cartridge holding cams are forced over the top

RESTRICTED—Security Information

of the cartridge holding cam springs. The holding cams prevent the last two rounds in the mouth from re-entering the feed mechanism and, in so doing, position the lower round in the mouth so that it can be removed by the breechblock.

e. The driving mechanism is powered by the drive spring, which is wound by the recoil of the gun. As the gun recoils and counter-recoils, the operating lever actuates the link-operating crank; the crank, in turn, actuates the two link assemblies that connect the operating crank with the clutch drive pockets (fig. 74). During recoil, the rear clutch drive pocket transmits motion through the clutch spring and hub to the main drive shaft, while the front clutch free-wheels. During counterrecoil, the actions of the front and rear clutches are reversed. Thus, the fore-and-aft motion of the operating lever is changed into rotary motion to actuate the main shaft assembly.

f. When the clutch drive pockets rotate in a direction to wind the drive spring, the clutch springs (fig. 74) tend to expand within the pockets. The force of this expansion causes the clutch spring to grip and be carried with the pocket as it rotates. The clutch driven hub is pinned to the main drive shaft and is also locked to the clutch spring (fig. 74). Therefore, the clutch assembly rotates as a unit, turning the main drive shaft, which winds the drive spring through the drive spring driver (fig. 74). While one clutch assembly is revolving in the winding direction, the other revolves in the opposite direction, causing the clutch spring to contract within the pocket, thus relaxing its grip. This permits the pocket to revolve freely in the opposite main shaft. This action causes the main drive shaft to always be rotated in the proper direction to wind the drive spring, even though the clutch drive pockets are reversing their directions every half cycle of gun operation.

g. As the main drive shaft is rotated, the small end of the drive spring grips and revolves with the drive spring driver (fig. 74) and winds the larger portion of the drive spring. The front end of the drive spring is anchored to the front star wheel, which it rotates. The drive spring is designed to wind to a maximum of 23 to 27 foot-pounds; however, this is output (useful) torque and does not correspond to the reading of a torque wrench used to wind the shaft, which will be considerably higher because of nonuseful torque required to expand the drive spring to the slipping point and to overcome friction. Overwinding the drive spring is prevented by the torque-stabilizer action. When the gun recoils more than eleven-sixteenths of an inch, the drive spring driver revolves through an angle greater than that through which the driving mechanism is required to revolve in order to feed one round into the gun. Such a condition would overwind the drive spring if the torque stabilizing

RESTRICTED

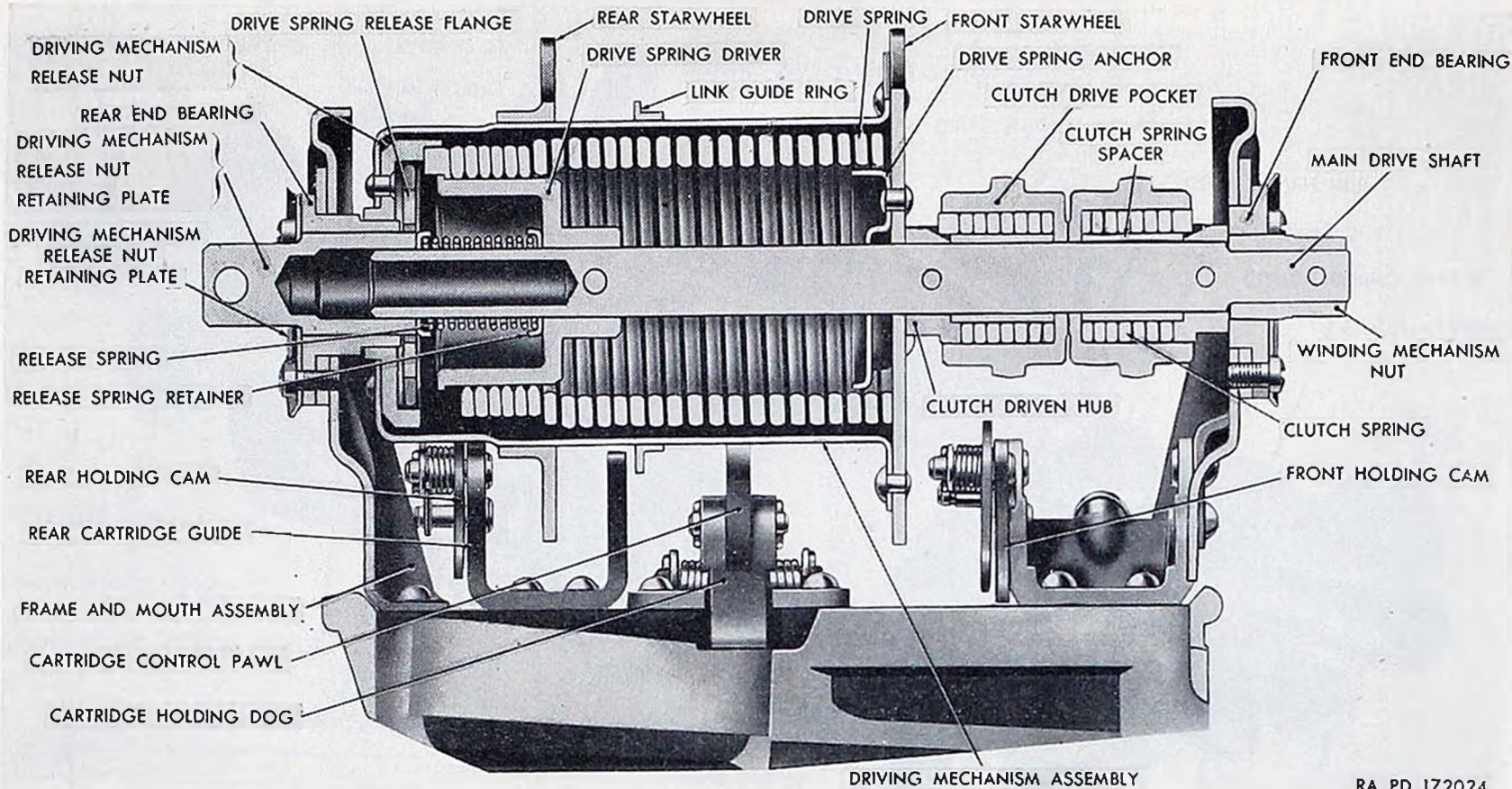

RESTRICTED—Security Information

RA PD 172024

Figure 74. Cross-sectional view of driving mechanism.

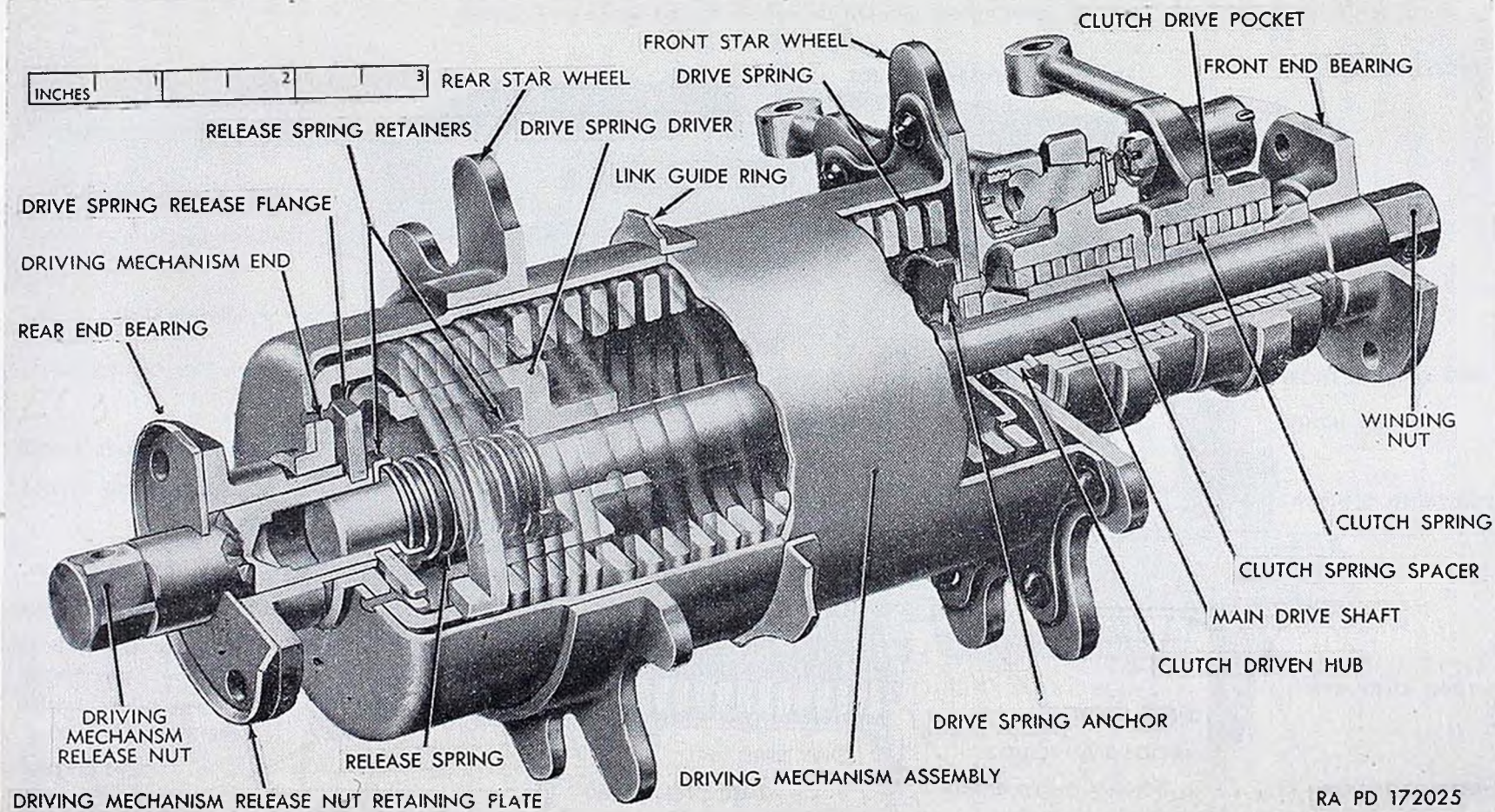

Figure 75. Driving mechanism and clutch group—cutaway view.

RESTRICTED—Security Information

action did not function to dissipate excess energy of recoil. To overcome this, the projection on the star wheel and exerts a force on the small coils of the spring, causing them to relax their grip on the driver, until the driver can revolve within the spring and still maintain full drive spring force. This action insures that the spring will always be wound by the driver until the driving mechanism end, which revolves with the driving mechanism, is contacted by the drive spring lug. It also prevents the drive spring from being overwound because the contact of the lug with the driving mechanism end prevents further winding of the drive spring (figs. 74 and 75).

h. The drive spring may be unwound by pushing the drive spring release shaft forward, so that the drive spring release flange (figs. 74 and 75) contacts the drive spring lug, and revolving the release shaft in the direction opposite to that of winding. When the release shaft is turned in this direction, the release shaft flange exerts a force on the drive spring through the lug and causes it to relax its grip on the spring driver. This allows the drive spring to be revolved on the driver by the rotation of the release shaft and thus the spring is unwound. The release shaft is returned to its nonoperating position (rearward) by its release spring (figs. 74 and 75).

Section VI. TROUBLE SHOOTING

58. General

The purpose of trouble shooting is to determine the defective components by making a systematic check of the probable causes of the malfunctions and to apply corrective measures. The extent of trouble shooting in this section is governed by the scope of the organizational maintenance.

59. Stoppage and Misfire

All stoppages will be considered as misfires if the gun is not readily accessible.

60. Stoppage During Ground Firing

In case of a stoppage, make two more attempts to fire by closing the switch. If the gun still does not fire, *wait 10 seconds*, recharge the gun, and remove the round to a safe place. Always wait 10 seconds before recharging the gun to avoid the possibility of a delayed explosion taking place after the round has been removed from the chamber.

RESTRICTED—Security Information

Table III. Trouble Shooting

Malfunction	Probable causes	Corrective action
Failure to feed-----	Improper magazine slide adjustment.	Adjust properly (par. 21 <i>b</i> (9)(<i>f</i>)).
	Broken anchor parts-----	Replace (par. 82 <i>b</i> and <i>d</i>).
	Round jammed in mouth of feed mechanism.	Remove and inspect mouth.
	Link jammed-----	Clear jam and replace defective link.
	Belt broken-----	Replace defective links.
	Faulty ammunition-----	Replace.
	Excessive friction in feed mechanism.	Lubricate operating parts.
	Insufficient recoil of breechblock.	Remove burs from interior of receiver, breechblock, push rods, or gas cylinder sleeve and piston.
Failure to fire chambered round.	Defective ammunition-----	Treat as misfire.
	Broken or shorted firing circuit due to—	
	Weak or broken firing spring.	Replace (pars. 70, 71, 73, 74).
	Broken, deformed, or burred firing pin.	Replace (pars. 70, 71, 73, 74) or remove burs with a fine oilstone and crocus cloth.
	Broken or deformed firing pin guide.	Replace (pars. 70, 71, 73, 74) if insulator, sleeve, or bushing is broken or deformed.
	Defective breechblock slide key.	Replace breechblock slide plate assembly (pars. 70, 71, 73, 74) if insulator on key is loose or missing.
	Broken or deformed contact wire.	Replace breechblock contact (par. 81 <i>b</i> and <i>e</i> or <i>c</i> and <i>f</i>).
	Defective cable-----	Replace cable (par. 81 <i>b</i> and <i>e</i> or <i>c</i> and <i>f</i>) if wires are separated from connector or ferrule.
Failure to extract---	Broken extractor spring, pin, or extractor.	Replace (pars. 70, 71, 73, 74).
	Carbon deposit in chamber--	Clean chamber (par. 46 <i>b</i> (1)).
	Dirty or improperly waxed ammunition.	Wipe the dirt off ammunition; use only waxed ammunition.
Failure to eject-----	Broken ejector stud or ejector.	Replace (par. 82 <i>b</i> and <i>d</i>).

RESTRICTED—Security Information

Caution: If the barrel is hot and the round cannot be fired, the round must be allowed to remain in the chamber for a minimum of 5 minutes because of the possibility of a cook-off. Cook-offs normally take place between 10 seconds and 5 minutes after the round is loaded into the hot barrel. If the round is removed too soon there is danger that the extracted round will explode outside the gun. However, it is safe to fire the round in the barrel during this interval.

61. Misfire During Air Firing

In case of a misfire, make two more attempts to fire by closing the switch. If the gun still does not fire, recharge the gun. If the gun cannot be recharged, no corrective action is possible.

62. Other Malfunctions and Corrections

The probable causes and the corrective measures for other malfunctions are listed in table III.

Section VII. CRADLE GROUP

63. General

a. The cradle (fig. 76) is fixed in the airplane installation and, during firing, remains stationary while the recoiling parts of the gun move to the rear in recoil and come forward in counterrecoil. The recoil housing of the gun is supported on trunnion blocks and the receiver of the gun slides on rollers which control the vertical movement of the gun. The sides of the cradle have drilled and tapped holes for mounting the chargers M4 and M6.

b. The anchor support bracket (fig. 77) is bolted to the top of the trunnion block to provide support for the magazine slide anchor, which prevents the magazine slide from moving during recoil. This feature is used in the operation of the feed mechanisms during firing, as the feed mechanisms are recoil-operated.

64. Maintenance

a. Check cradle for condition and for tightness of assembled components.

b. Tighten loose screws and apply lock-wire. Oil the cradle rollers and check rotation. Remove brass chips and burrs from expended case opening. Notify field maintenance if parts are missing, broken, or show signs of fracture.

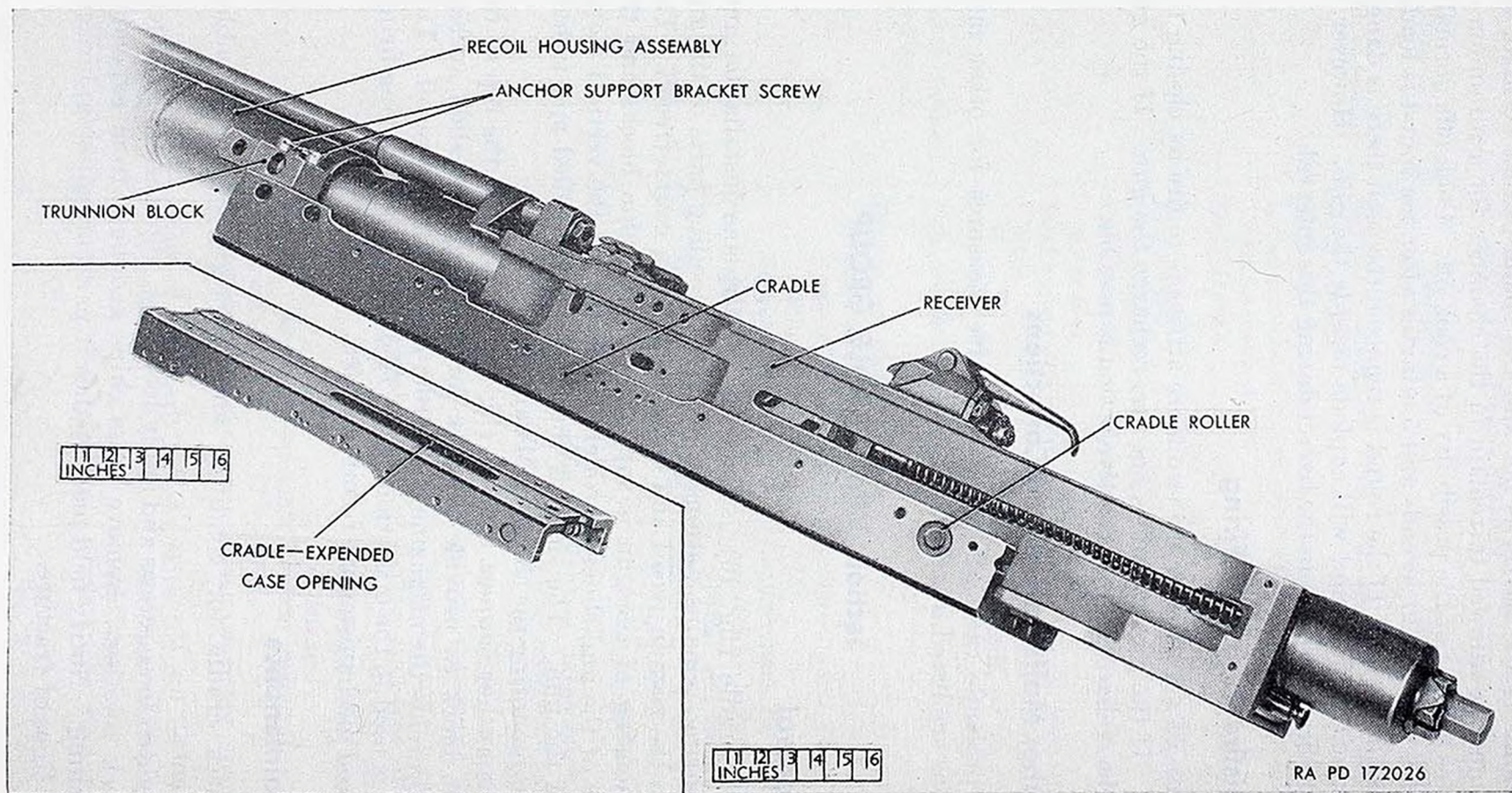

Figure 76. Cradle assembled to gun and view of bottom of cradle.

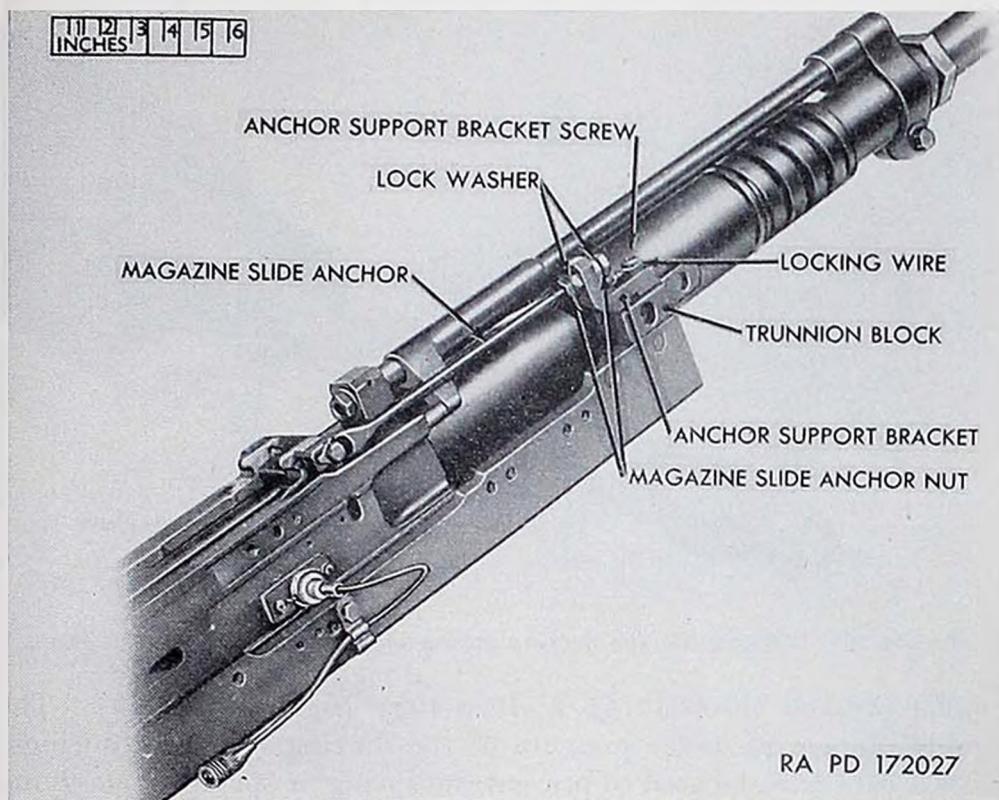

Figure 77. Anchor support bracket assembled to cradle.

Section VIII. DRIVING SPRING GUIDE GROUP AND REAR BUFFER ASSEMBLY

65. General

a. The driving spring guide assembly (fig. 58) fits through the rear buffer assembly into the bolt assembly with the driving spring or springs positioned between the head of the guide and the head of the plunger. In recoil, the breechblock compresses the driving spring and the firing pin spring plug compresses the spring inside the guide, which aids in retarding the rearward motion of the breechblock.

b. The rear buffer assembly acts as a shock absorber for the breechblock assembly. It arrests the recoiling of the breechblock and starts the breechblock forward. It consists of a housing that contains a coil spring nested in a series of ring springs and a washer. The washer transmits the shock of recoil to the springs.

c. The expansion of the compressed springs in the rear buffer assembly and the compressed driving spring guide plunger group give the breechblock assembly its forward motion.

66. Removal and Disassembly

a. Use a blunt cold chisel to straighten out bent portions of driving spring guide retainer (fig. 78). Unscrew guide plunger with rear

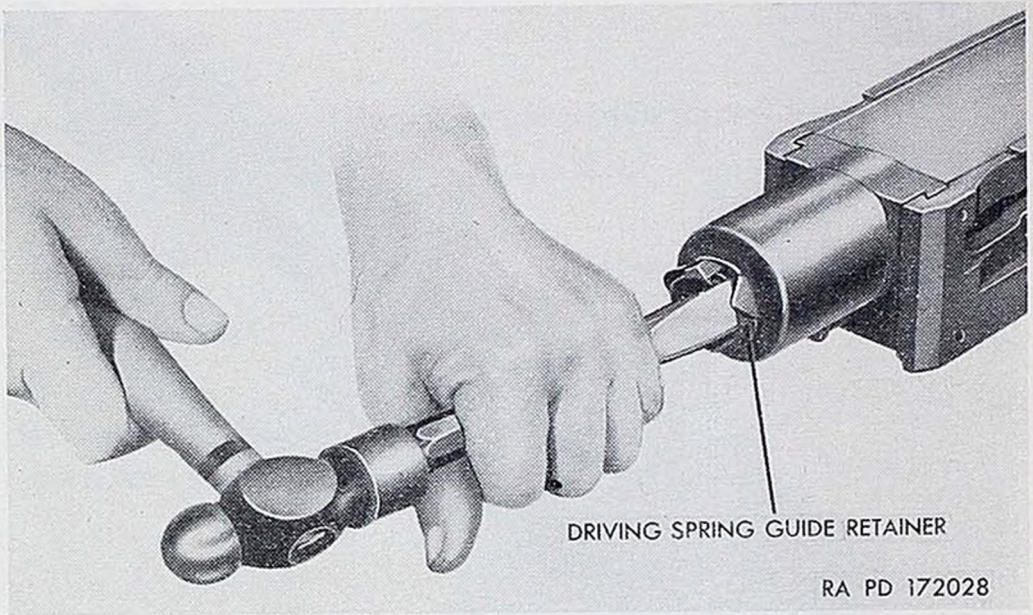

Figure 78. Disengaging the driving spring guide retainer from the guide.

buffer wrench 5570605 (41-W-1990-400) (figs. 44 and 79). The guide plunger is under pressure of the driving spring or springs; hence, care must be used to prevent the spring or springs from flying out while the guide plunger is being removed. Remove driving guide assembly with driving spring or springs (fig. 80). Slide driving spring or springs off guide plunger (figs. 10 and 11).

b. Use a blunt cold chisel to straighten out bent portion of driving spring guide cap lock plate and unscrew the driving spring guide cap (figs. 10 and 11). Remove guide spring from guide plunger (figs. 10 and 11).

c. Retract rear buffer lock plunger (fig. 81) and push rear buffer down and out of the dovetail slots of the receiver.

67. Maintenance

a. Replace driving spring or springs and driving spring guide springs if they are set, kinked, or broken.

b. Replace driving spring guide retainer and cap locking plate if broken or if they show signs of fracture.

c. Remove burrs from sliding surfaces of rear buffer housing and locking plunger; if plunger is broken, deformed, or inoperative or if buffer is otherwise damaged, notify ordnance maintenance personnel. Do not immerse rear buffer assembly in any type of cleaning fluid. The ring springs inside the housing are lubricated at manufacture; dilution of this lubricant with cleaning fluid will result in damage to the rear buffer assembly.

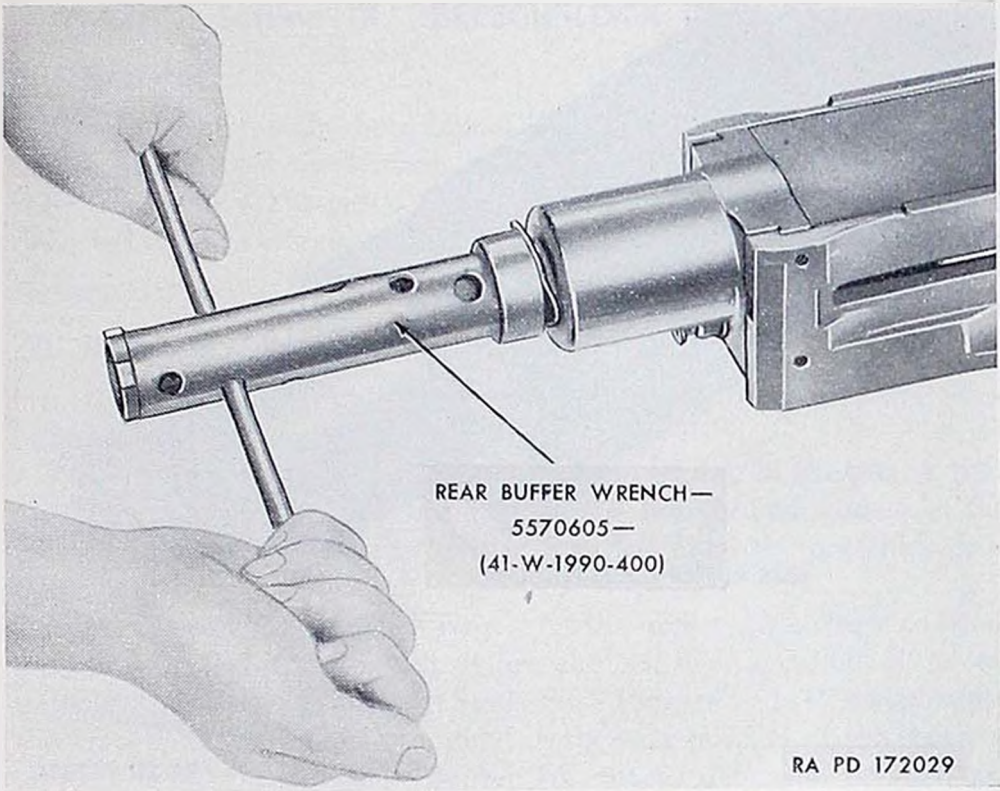

Figure 79. Removing guide plunger.

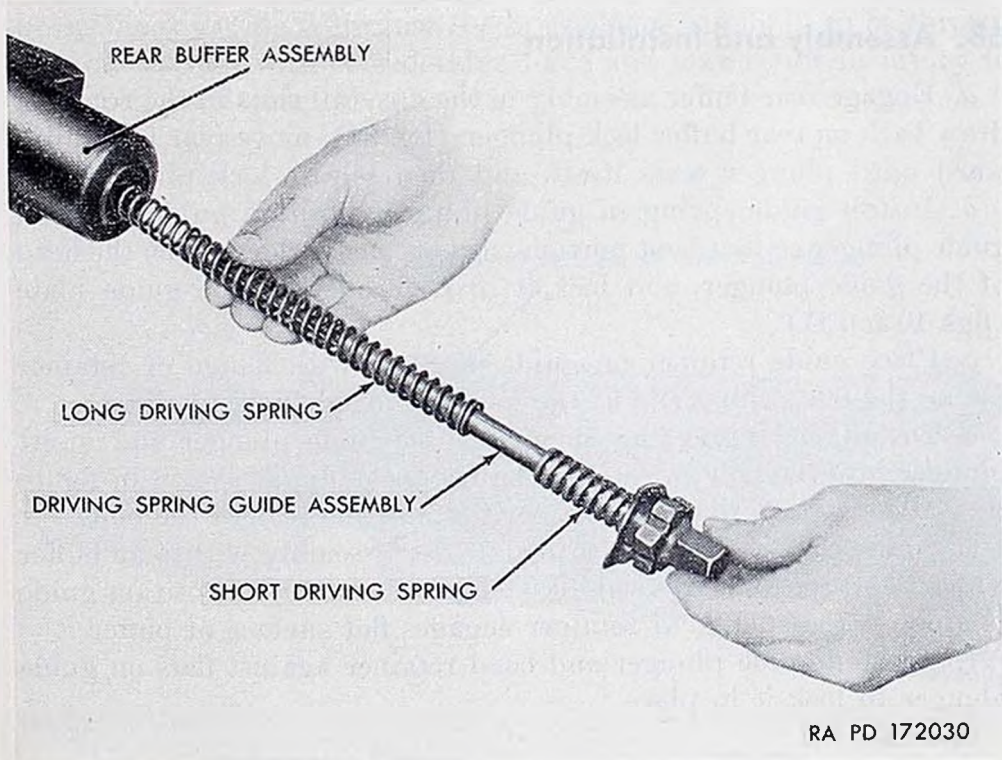

Figure 80. Removal of driving spring group.

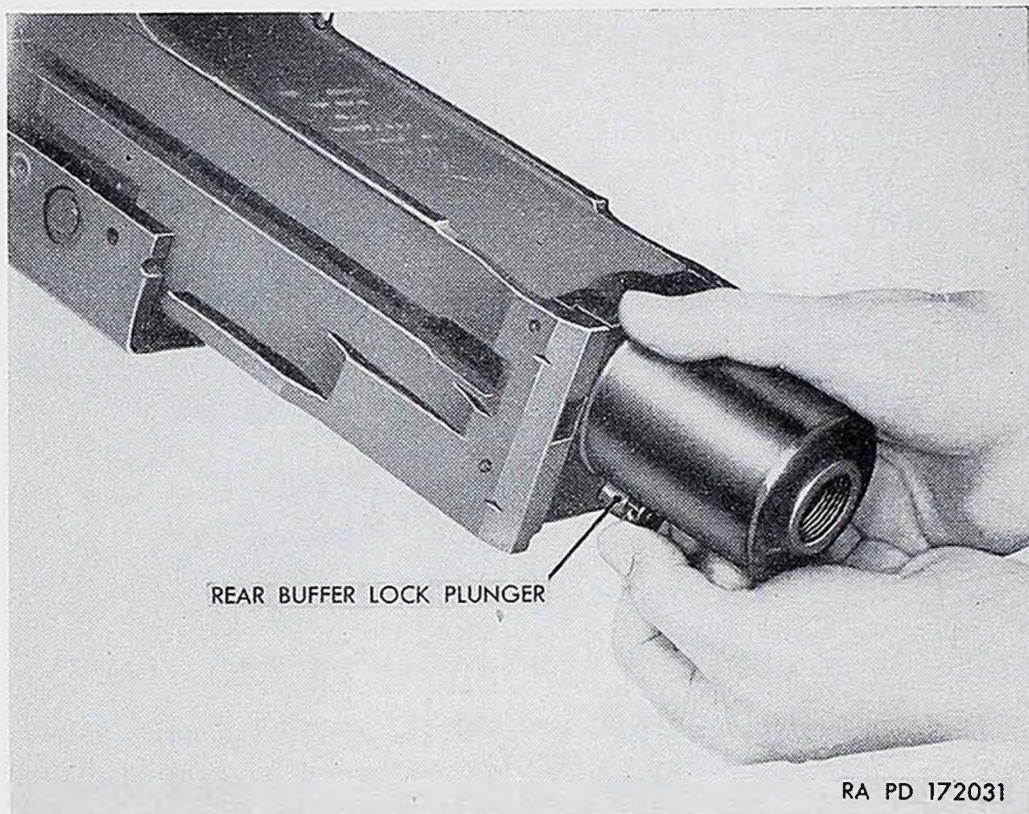

Figure 81. Retracting the rear buffer lock plunger.

68. Assembly and Installation

a. Engage rear buffer assembly in the dovetail slots in the receiver, draw back on rear buffer lock plunger (fig. 81), move rear buffer upward until plunger seats itself, and then release lock plunger.

b. Install guide spring in guide plunger, position guide plate on guide plunger so that bent portion engages one of the slots on the head of the guide plunger, and lock it in position with the guide plate (figs. 10 and 11).

c. Place guide retainer on guide plunger, with flange of retainer facing the telescoping end of the guide plunger (figs. 10 and 11).

d. Install driving spring or springs on guide plunger and insert plunger into the hole in the rear buffer assembly, as shown in figure 80. Make certain that the plunger fits into the rear of the bolt.

e. Screw guide plunger into rear buffer assembly with rear buffer wrench 5570605 (41-W-1990-400) (figs. 44 and 79). Position guide retainer so that flange of retainer engages flat surface of buffer.

f. Tighten guide plunger and bend retainer against flats on guide plunger to lock it in place.

RESTRICTED—Security Information

Section IX. BREECHBLOCK GROUP

69. General

The function of the breechblock is to carry the round from the mouth of the feed mechanism into the chamber, fire the round, extract the empty cartridge case, and support the case until it is deflected out of the receiver by the ejector. For detailed description of the functioning, see paragraphs 48 through 55.

70. Removal

a. Remove guide plunger and driving spring or springs and rear buffer assembly (par. 66).

b. Insert a screw driver through the top opening in the gun so that the blade is between the front face of the breechblock slide and the receiver and press the screw driver forward until the breechblock is unlocked.

c. Move breechblock to the rear. As the breechblock starts to come out of the receiver, take hold of breechblock lock and hold it in the unlocked position, as shown in figure 82. Failure to do this may cause the breechblock to become jammed in the rear portion of the receiver as it is being pulled out. Be careful not to drop the breechblock lock.

Caution: Do not actuate the pneumatic charger M4 in removing the breechblock as this will cause the breechblock assembly to be thrown free of the gun with considerable force and may result in injury to personnel and damage to materiel.

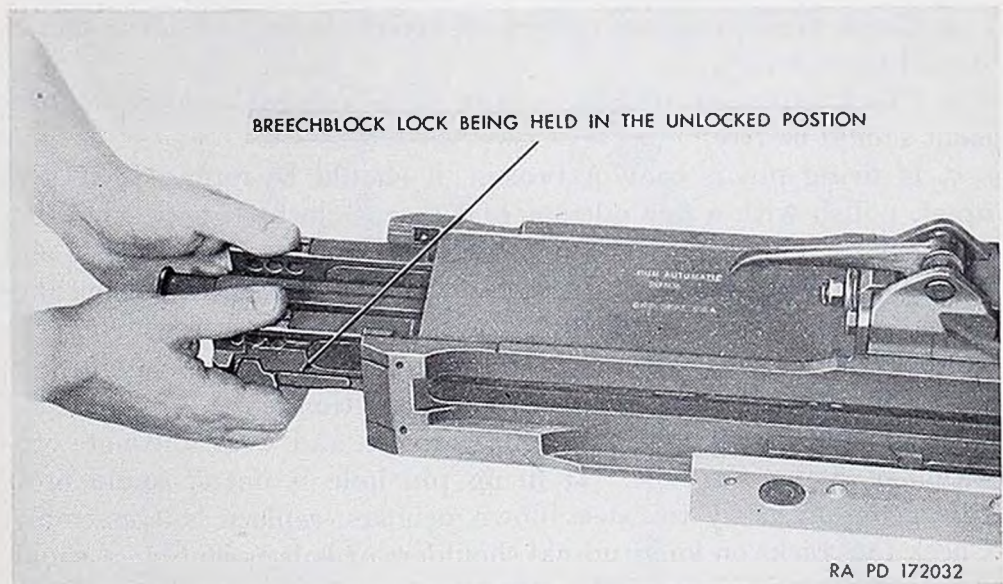

Figure 82. Removing breechblock from receiver.

71. Disassembly

(figs. 83 and 84)

- a.* Remove breechblock lock. Remove right and left inertia blocks.
- b.* Withdraw left breechblock slide and then breechblock slide plate assembly, exercising care not to let spring and guide fly out. Do not attempt to remove breechblock slide key from breechblock slide plate assembly.
- c.* Push extractor against extractor spring and remove extractor pin with a drift punch. Withdraw extractor and extractor spring.
- d.* Remove firing pin contact with firing pin contact extractor 7237734 (41-E-542-750) (figs. 44 and 85). It may also be removed by applying equal force at each end of the contact, pushing at the top inside, and pulling at the bottom outside; exercise care when using this method of removal as the contact can be easily deformed.
- e.* Insert breechblock and firing pin spring plug assembling tool 7237920 (fig. 44) into the bore of the bolt so that it engages the holes in the firing pin spring plug. While exerting pressure against the tool, drive firing pin spring plug pin out with a drift punch, gradually release pressure, and remove firing pin plug and firing pin spring. If the pressure is released too quickly, the firing pin plug and spring will fly out.
- f.* Carefully slide firing pin guide and firing pin out through rear of bolt.

72. Maintenance

- a.* Check freedom of movement of breechblock in the receiver; it should move freely.
- b.* Check movement of firing pin in guide and guide in bolt; movement should be free.
- c.* If firing pin is bent or broken, it should be replaced; if it is upset, polish with a fine oilstone and crocus cloth. Check condition of insulator on firing pin guide. Examine guide outer sleeve and inner bushing for cracks and breaks. If outer sleeve or inner bushing is cracked or broken or if insulator is damaged, replace firing pin guide. Check firing pin spring and breechblock slide springs for set, kinks, or cracks; replace if any of these conditions exist.
- d.* Examine front face of bolt for erosion and wear and note condition of firing pin hole. If firing pin hole is out-of-round or is enlarged sufficiently to cause blown primers, replace bolt assembly. Check for cracks on longitudinal shoulders of bolt assembly; if shoulders are cracked, replace bolt assembly.
- e.* If bolt retainers fail to hold a round, replace bolt assembly.

RESTRICTED

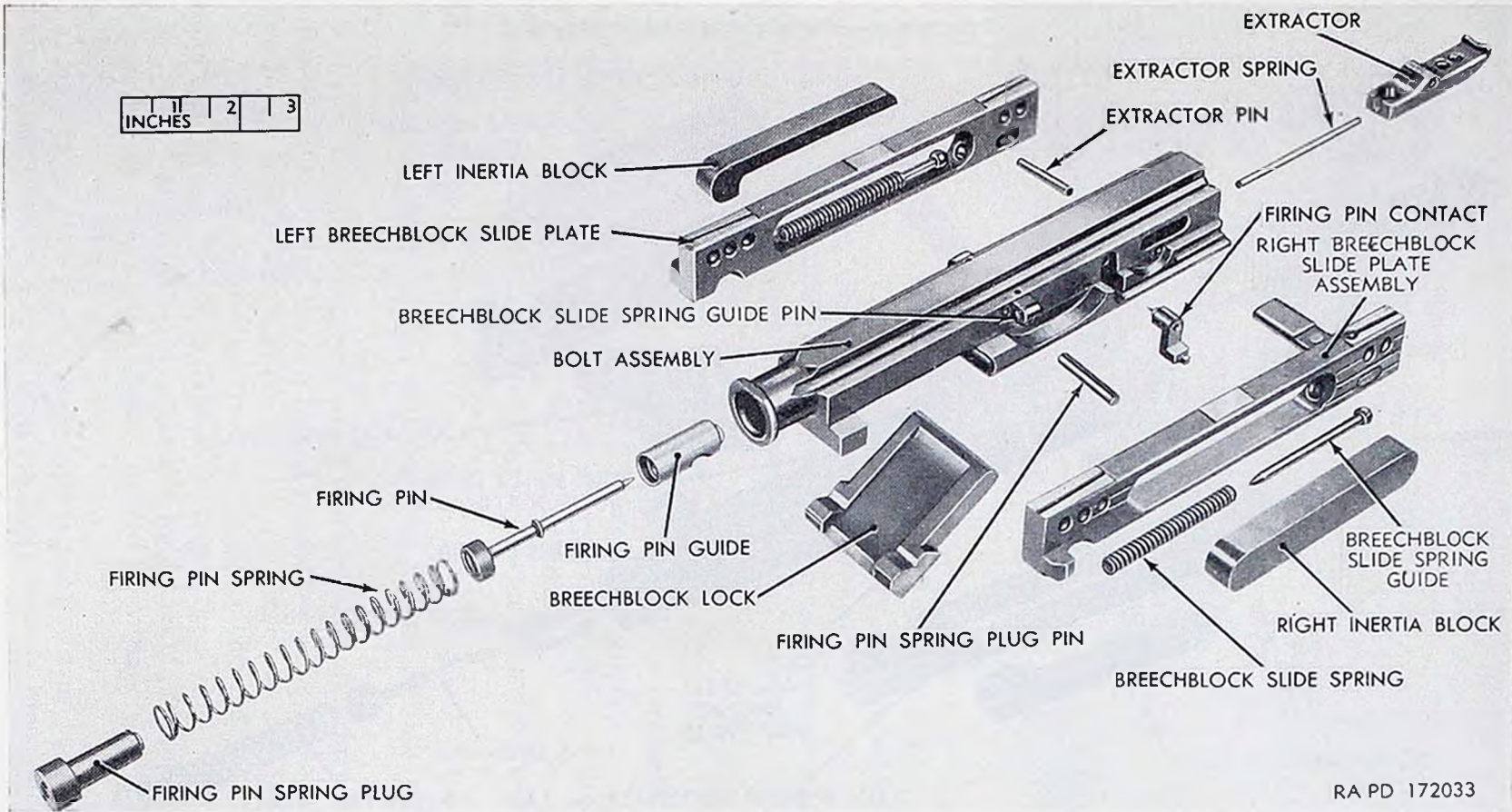

Figure 83. Breechblock group—Gun M24.

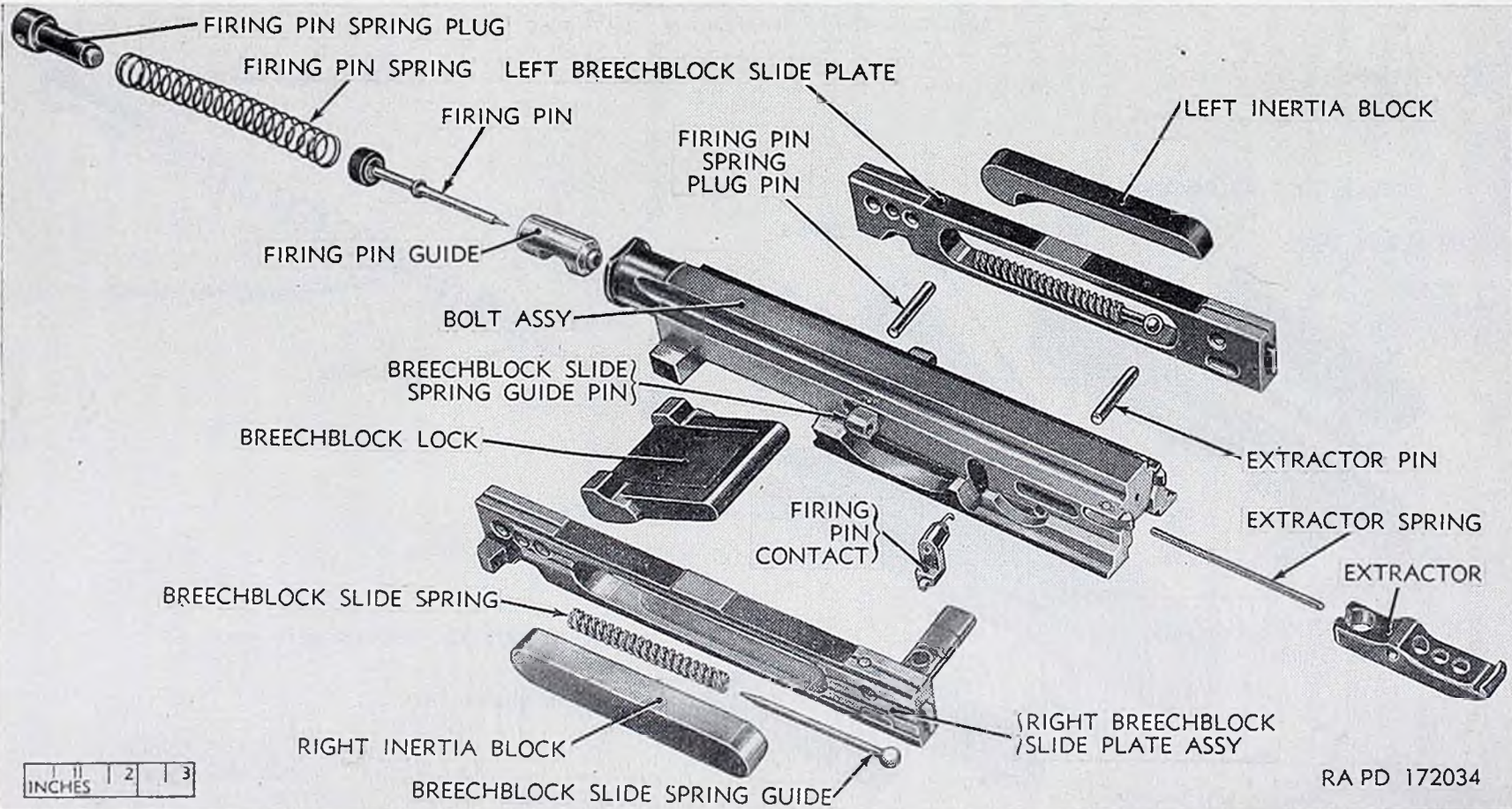

Figure 84. Breechblock group—Gun M2/A1.

RESTRICTED—Security Information

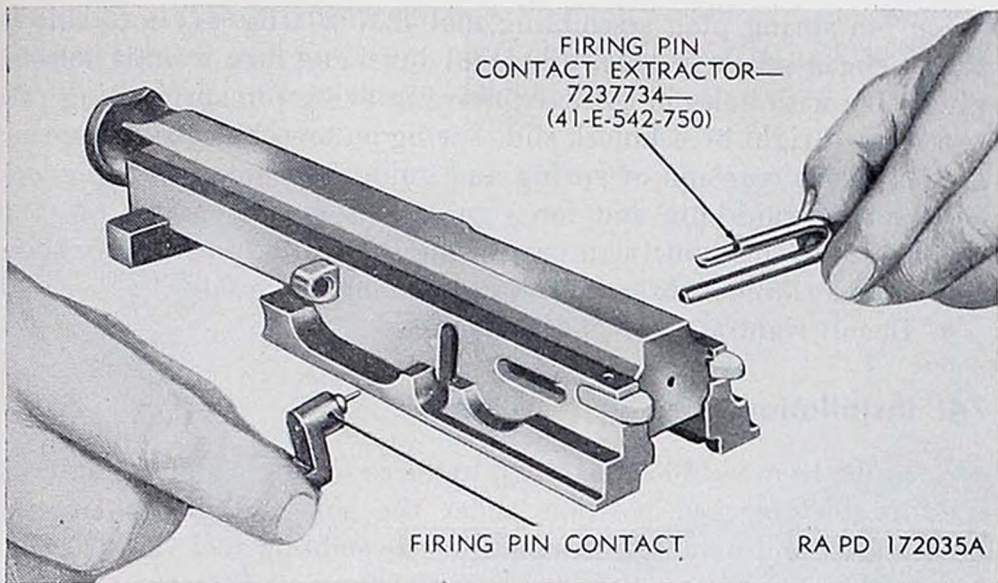

Figure 85. Removing firing pin contact.

f. Examine breechblock lock carefully for condition of cams on both sides and for wear or roughness on hinging lock surfaces. Check undersides for wear. Replace if worn or cracked.

g. Examine breechblock slide plates for damaged plate contacts and worn insulation on slide key and loose slide key; replace slide plates if any of these conditions exist.

Note. Replace slide plates as a matched set.

h. Replace firing pin spring plug if insulation is damaged.

i. Replace firing pin spring if set, kinked, or cracked.

j. Replace extractor spring if set or cracked. Replace extractor if it shows signs of fracture or if lip is damaged.

k. Replace extractor pin and firing pin spring plug pin if damaged.

73. Assembly

a. Install extractor spring and extractor and secure them with extractor pin.

b. Place firing pin in firing pin guide and slide unit forward into bolt. The slots in the firing pin and guide should be placed so that they align with the recess in the bolt for the breechblock slide key.

c. Press firing pin contact into the required side of the bolt assembly, being careful not to deform contact wire.

d. Install breechblock slide plate assembly, making certain that key of breechblock slide plate assembly interlocks with slots of firing pin and firing pin guide.

e. Insert firing pin spring in the bolt and follow with the firing pin spring plug (narrow end of plug leading). Insert breechblock and

RESTRICTED—Security Information

firing pin spring plug assembling tool 7237920 (fig. 44) into bolt so that it engages hole in plug, press tool down and turn it until holes in plug align with holes in bolt, and drive in firing pin spring plug pin.

f. Install right breechblock slide spring on breechblock slide spring guide. Place rear end of spring and guide into hole in breechblock slide spring guide pin and force guide and spring against pin and sideways into slide until ball part of guide is seated in recess in slide. Similarly, install left breechblock slide spring and guide.

g. Install right and left inertia blocks.

74. Installation

a. Slide the breechblock partly into the receiver. Hold breechblock lock in the unlocked position under the bolt and manipulate the breechblock and firing pin spring plug assembling tool 7237920 (fig. 44) so that the lug on the arm engages in third hole from rear of the breechblock slide and the body of the tool pivots against the rear lower face of the bolt assembly, as shown in figure 86.

b. Pull back on the upper end of the body of the breechblock and firing pin spring plug assembling tool 7237920 until the recesses in

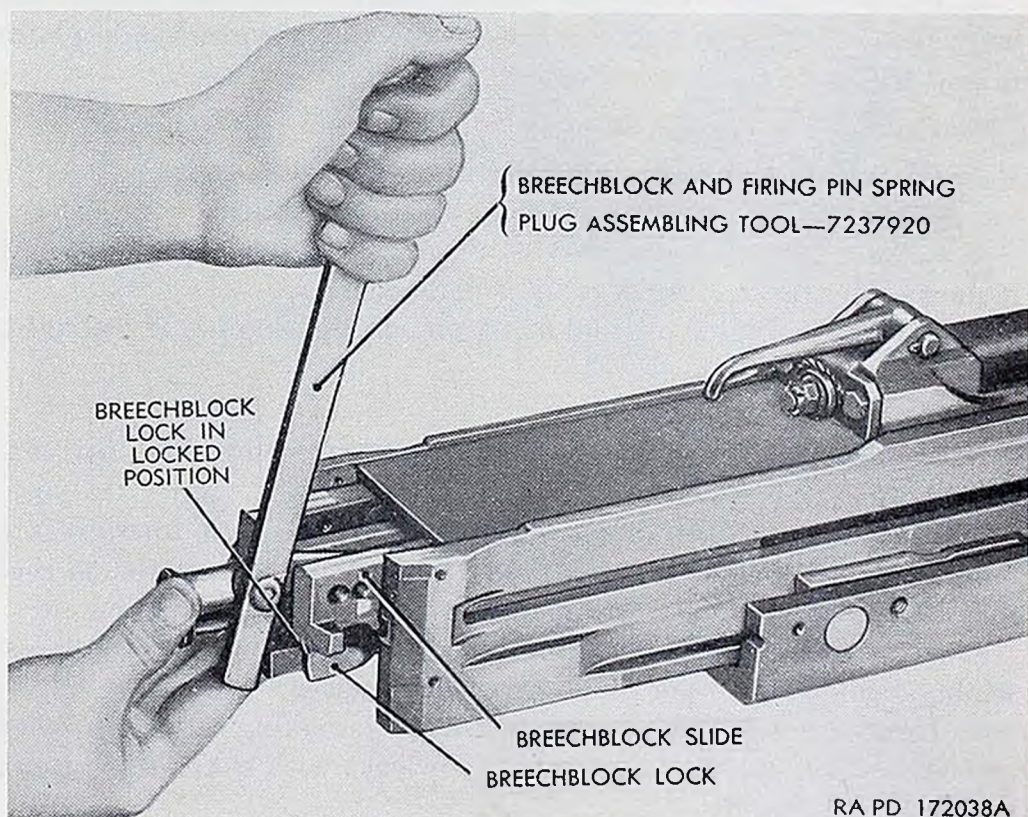

Figure 86. Positioning the breechblock and firing pin spring plug assembling tool 7237920 for installation of breechblock.

RESTRICTED—Security Information

the slides are directly over the lugs on the breechblock lock, press up the breechblock lock until it is in the unlocked position, and then push the breechblock home, as shown in figure 87.

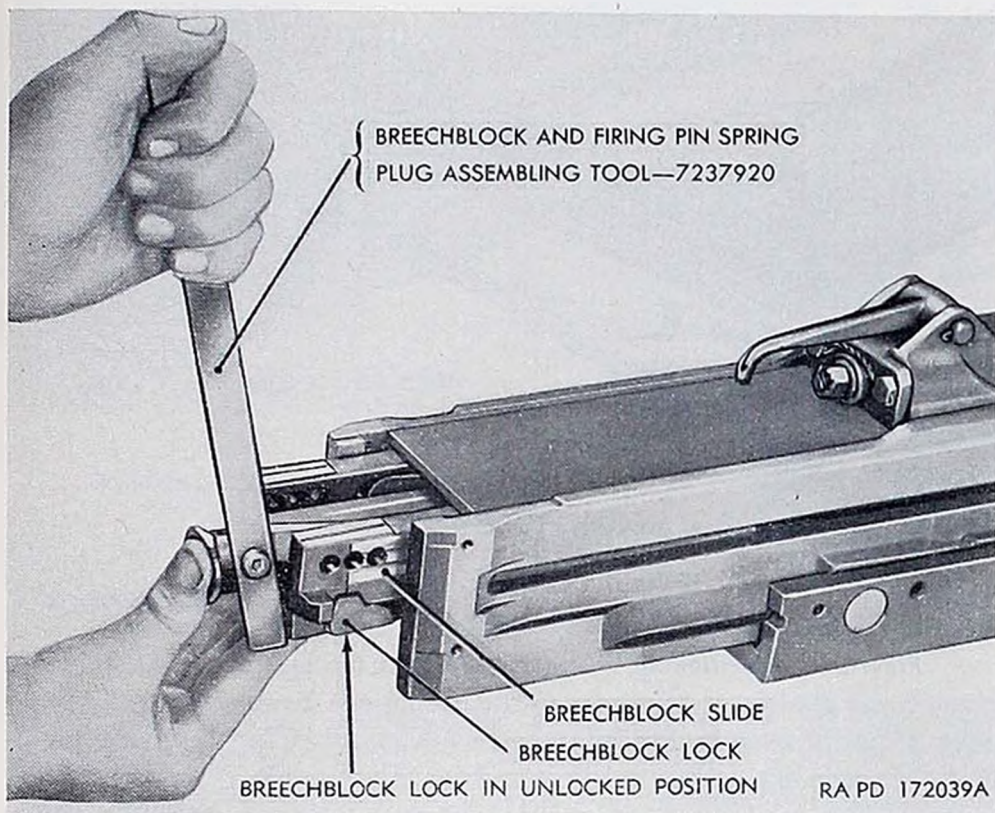
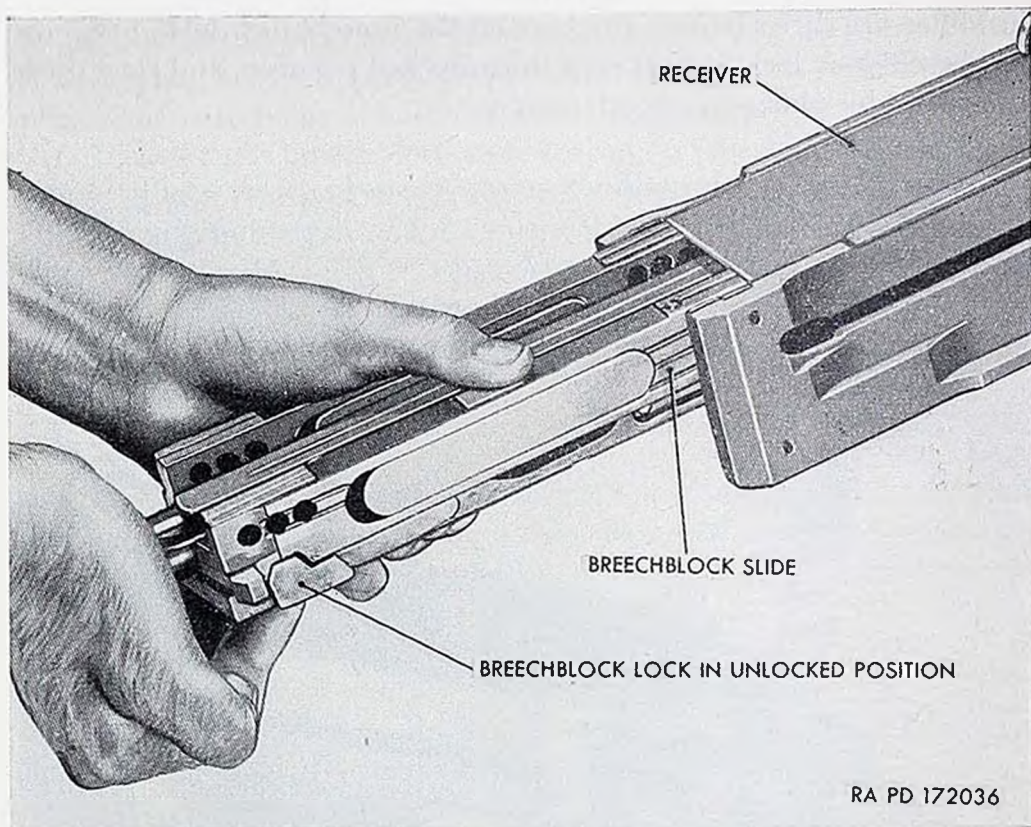

Figure 87. Positioning breechblock lock in unlocked position, using breechblock and firing pin spring plug assembling tool 7237920.

c. If the breechblock and firing pin spring plug assembling tool 7237920 (fig. 44) is not available, use the method described in (1) and (2) below for installing the breechblock.

- (1) Install breechblock lock by forcing breechblock slides rearward and, at the same time, exerting pressure against the breechblock lock until it is in the unlocked position, as shown in figure 88. A convenient point for the application of the pressure is the rear end of the top plate of the receiver, provided that the gun is secured to the bench so that it cannot slide.
- (2) Insert breechblock into the receiver as far as it will go, exercising care to keep breechblock lock in unlocked position (fig. 89), and push breechblock home.



RA PD 172036

Figure 88. Positioning breechblock lock in the unlocked position.

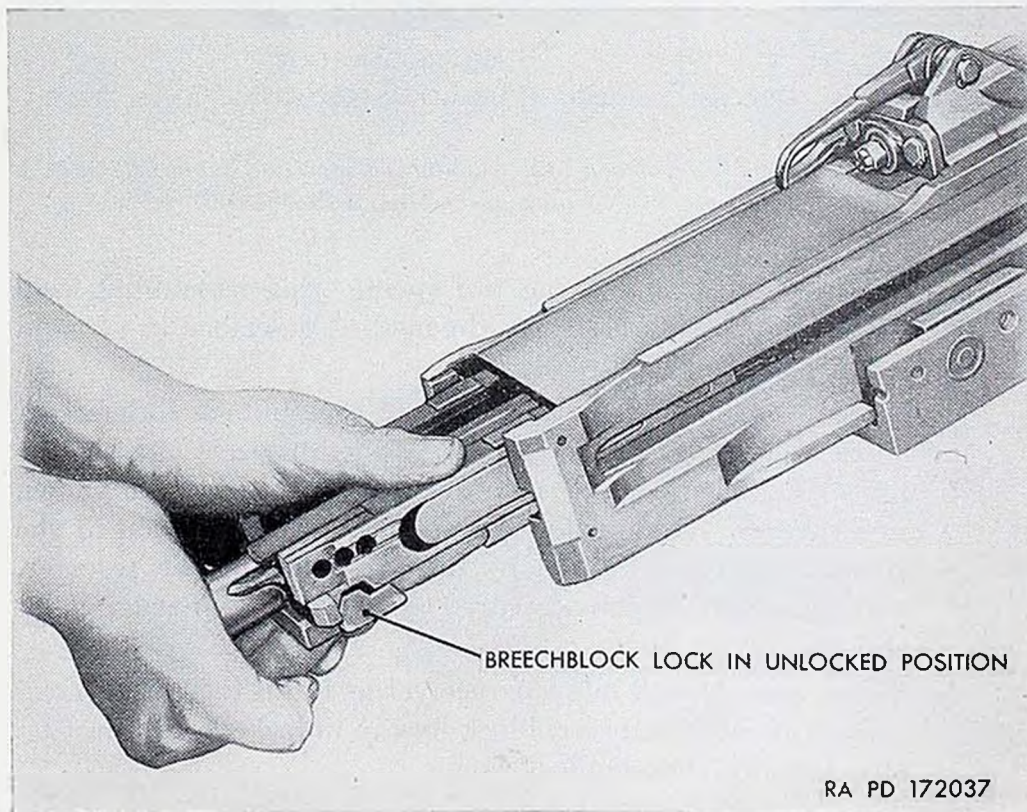

RA PD 172037

Figure 89. Installing breechblock in receiver.

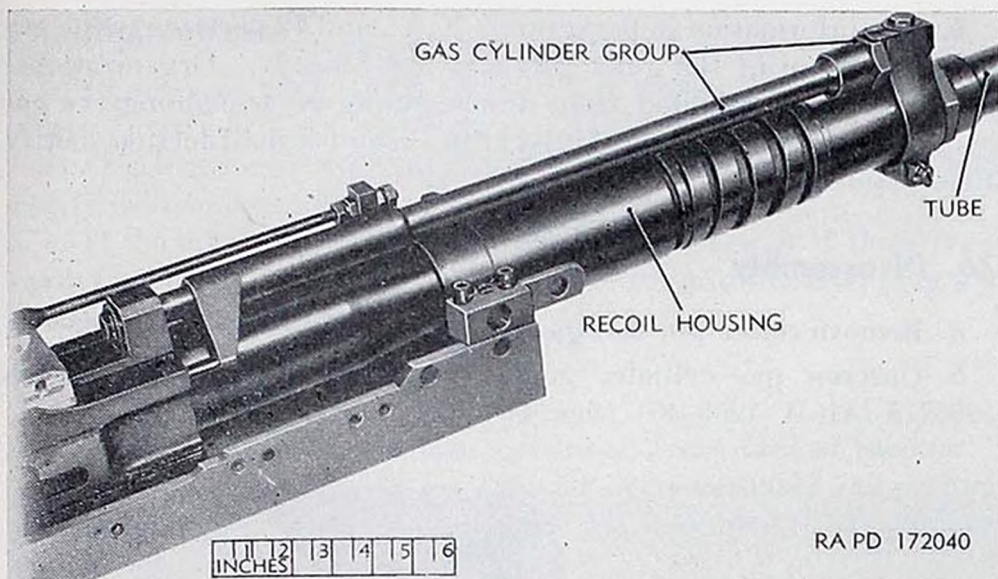

Figure 90. Gas cylinder group—guns M24 and M24E2.

Section X. GAS CYLINDER GROUP

75. General

(figs. 90 and 91)

a. The function of the gas cylinder group is to unlock the breechblock so that it can be forced back by straight blow-back action. Refer to paragraph 50 for details of functioning and to paragraph 4b(2) for differences between the groups in the guns M24, M24A1, and M24E2.

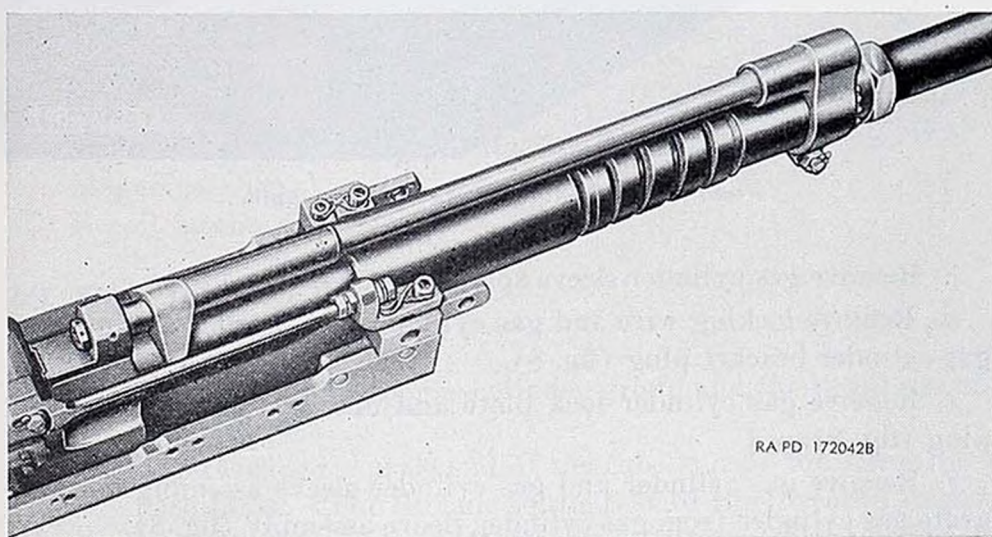

Figure 91. Gas cylinder group—gun M24A1.

RESTRICTED—Security Information

b. The information in paragraphs 76, 77, and 78 pertains to the gas cylinder group of the guns M24 and M24E2 only. Organizational personnel are prohibited from disassembling or assembling the gas cylinder group of the gun M24A1; in case of a malfunction, notify field maintenance.

76. Disassembly

- a. Remove cotter pin and gas cylinder guide lock washer (fig. 8).
- b. Unscrew gas cylinder guide (fig. 8) with engineers wrench 5206718 (41-W-1209-40) (figs. 44 and 92).

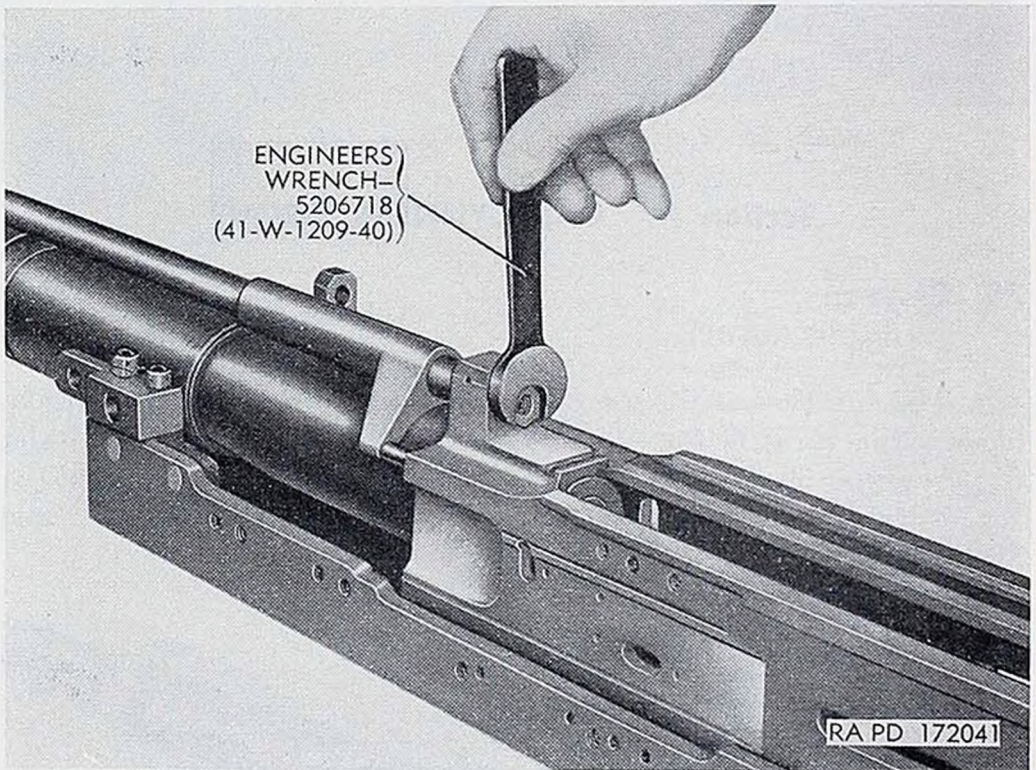

Figure 92. Removing gas cylinder guide.

- c. Remove gas cylinder sleeve spring (fig. 8).
- d. Remove locking wire and gas cylinder lock washer and unscrew gas cylinder bracket plug (fig. 8).
- e. Remove gas cylinder lock plate and unscrew gas cylinder vent plug (fig. 8).
- f. Remove gas cylinder and gas cylinder sleeve assembly and separate gas cylinder from gas cylinder sleeve assembly (fig. 8).
- g. Remove push rods (fig. 8) from recesses in front face of receiver.

RESTRICTED—Security Information

77. Maintenance

a. Check vent plug for looseness; if it cannot be tightened sufficiently, notify field maintenance.

b. Check gas vent hole for erosion; if diameter exceeds 0.092 inch, notify field maintenance.

c. If the bracket plug becomes loose during firing or if there is excessive plug bevel safety-wire the bracket plug to the vent plug and notify field maintenance.

78. Assembly

a. Fit push rods (fig. 8) into recesses in front face of receiver.

b. Install gas cylinder on gas cylinder sleeve assembly and position unit on gun tube so that gas cylinder fits into gas cylinder bracket (fig. 8).

c. Screw in gas cylinder vent plug and install gas cylinder lock plate (fig. 8).

d. Screw in gas cylinder bracket, install gas cylinder lock washer, and secure with locking wire (fig. 8).

e. Install gas cylinder sleeve spring in gas cylinder sleeve assembly and screw in gas cylinder guide and tighten it with engineers wrench 5206718 (41-W-1209-40) (figs. 44 and 92).

f. Install gas cylinder guide lock washer and cotter pin (fig. 8).

Section XI. TUBE AND RECEIVER GROUP

79. General

For purposes of removal, disassembly, maintenance, assembly, and installation, the following components are grouped as the tube and receiver group:

Gun tube.

Receiver and breechblock contact parts.

Magazine slide.

Recoil mechanism.

80. Gun Tube

a. *General.*

(1) The tube holds the gas cylinder group and the recoil mechanism (fig. 93).

(2) The threaded muzzle end of the tube is used for attaching a flash hider. The threads to the rear of the threaded muzzle end (fig. 93) serve for attaching certain types of British mounts, but are not used for mounting the guns in United

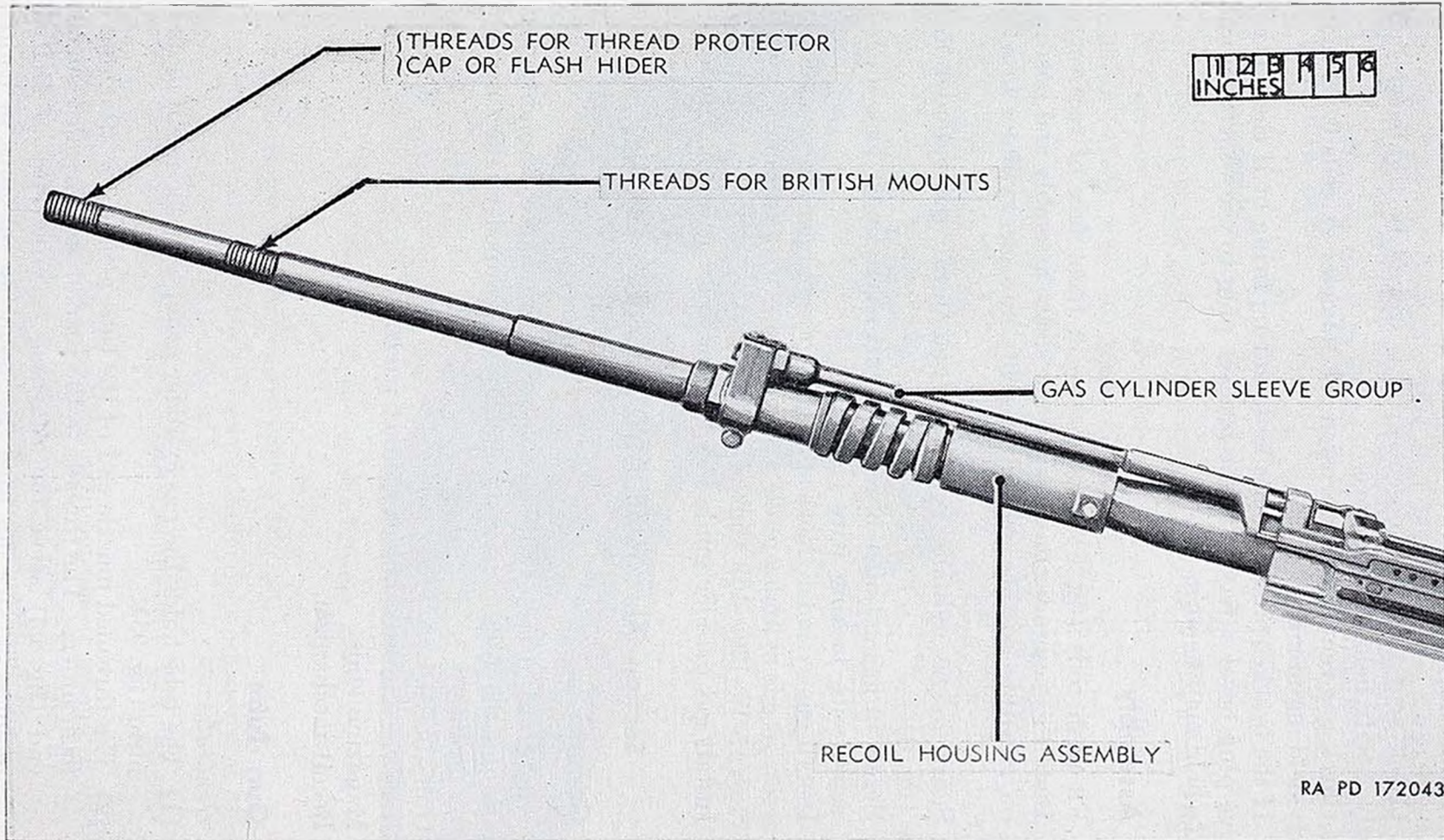

RA PD 172043

Figure 93. Gun tube showing components mounted on tube—gun M24.

RESTRICTED—Security Information

States aircraft. The threads for British mounts appear on the tube for gun M24 only and are not on the tubes for gun M24A1. When these threads are not in use, they are covered and protected by a thread protective sleeve and cap (M24 only) and a thread protector cap (M24A1 and M24E2), as shown in figure 13.

- (3) For differences between the gun tubes of the guns M24 and M24E2 and M24A1 refer to paragraph 4b(4).

b. Removal and Installation of Thread Protector Sleeve and Cap (fig. 13).

- (1) To remove, unstake thread protector cap and unscrew cap; slide off thread protector sleeve (M24 only).
- (2) To install, slide on thread protector sleeve (M24 only) and screw on thread protector cap and stake it.

c. Maintenance.

- (1) Gun tubes become copper-fouled to less extent when they are cared for in the proper manner. Wear in the bore does not depend entirely upon the number of rounds fired. It depends also upon the care given the bore in cleaning and cooling between periods of firing. Since the accuracy life of a gun tube is decreased by a fast rate of firing and the attendant heat, the gun should be allowed to cool as often as possible. It is important to inspect the bore, whenever possible, and to make certain that it does not contain foreign particles that might cause damage to the gun. Gun tubes will be inspected by field maintenance personnel for remaining tube life.
- (2) Prior to firing, clean the bore of the tube if the bore is heavily oiled or if muzzle covers are not used.
- (3) To clean bore after firing, run several patches of bore-cleaning cloth, impregnated with rifle-bore cleaner, through bore from breech end. Remove patch from cleaning staff M13 5570631 (fig. 44) and attach bore brush M25 7225087 (fig. 44). Run brush through bore several times. Make certain that brush goes all the way through before reversing its direction. If rifle-bore cleaner is not available, use warm soapy water or warm water alone. Remove brush and run several patches, wet with clean water, through chamber again, and follow this with dry patches until they come out clean and dry. Failure to remove all traces of water from the receiver and the bolt is apt to result in malfunctioning of gun at low temperatures. Oil gun immediately after drying it.

81. Receiver and Breechblock Contact Parts

a. *General* (figs. 94 and 95).

- (1) The receiver houses the breechblock assembly and most of the working parts of the gun. The gun tube screws into the front of the receiver, the rear buffer assembly slides into dovetail grooves in the rear, and the magazine slide is housed in guide-ways on top of the receiver.
- (2) Empty cartridge cases are ejected through an opening in the bottom of the receiver. Above the ejector opening are

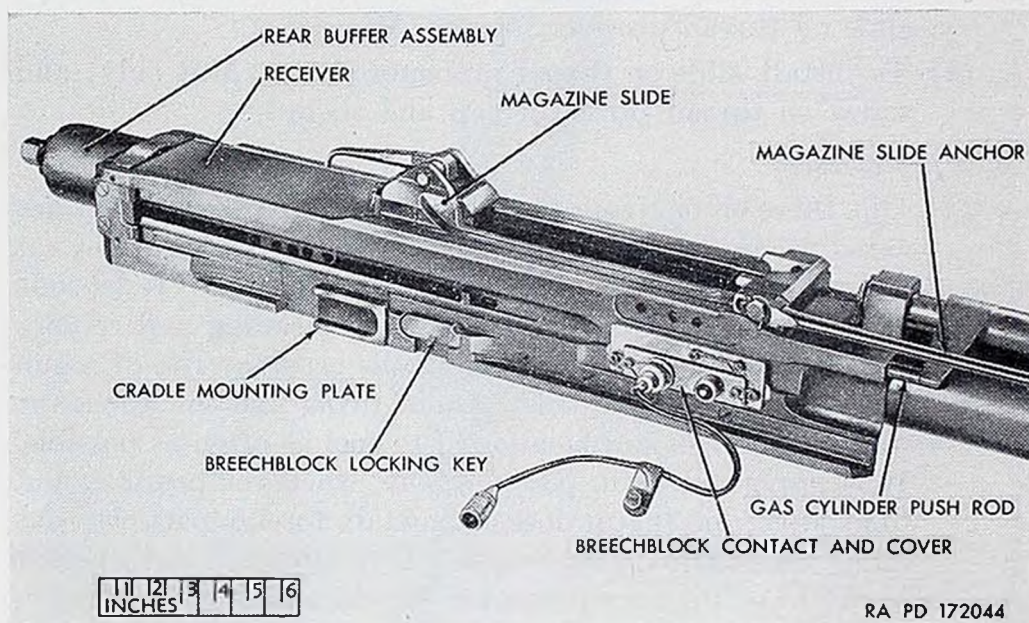

Figure 94. Receiver—top-right view—gun M24.

two receiver slides, which are bolted to the side of the receiver and serve to support the breechblock in its forward movement. The slides have cammed surfaces at the rear, which engage corresponding cams on the breechblock lock, to cam it into the locked position with the assistance of the camming action of the breechblock slides. To the rear of the ejector opening, a slot is cut into each side of the receiver body to accommodate the breechblock locking key. The breechblock locking key engages the breechblock lock when the lock is cammed down into the locked position (fig. 63).

- (3) The cradle mounting plate, fastened on the underside of the receiver, supports the gun and controls its vertical movement by means of cradle rollers fitted into the gun cradle.

RESTRICTED—Security Information

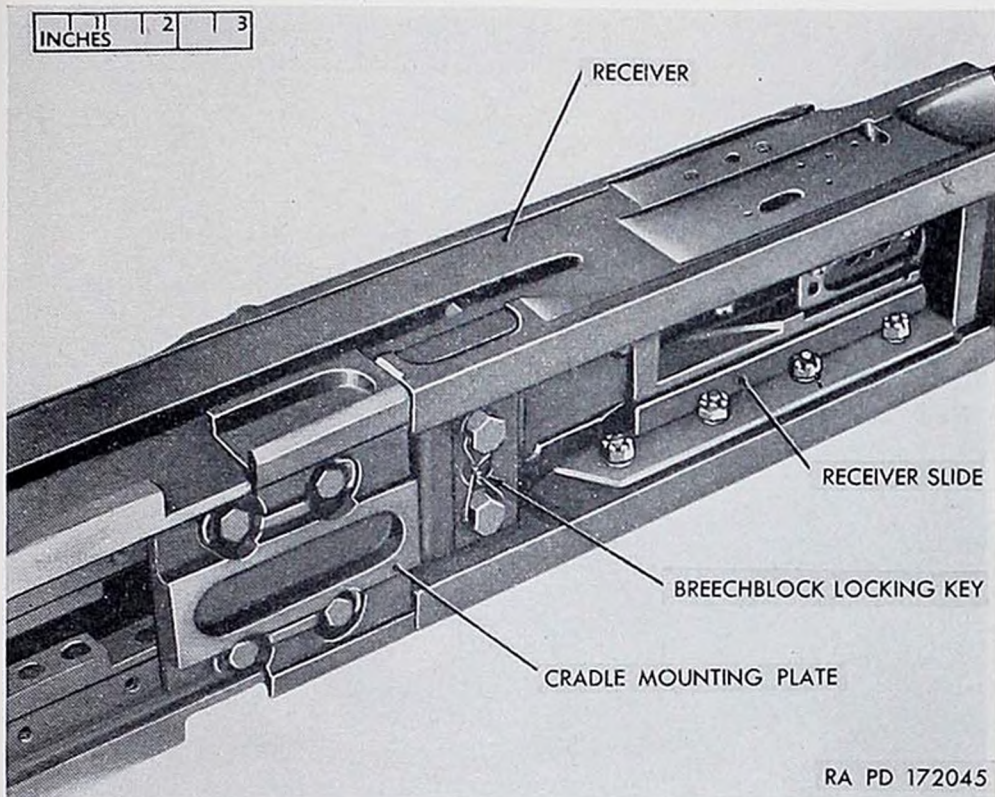

Figure 95. Receiver—bottom view—gun M24 or M24A1.

- (4) The function of the breechblock contact is to furnish a path by means of which the ignition current can reach the firing pin through the firing pin contact. The breechblock contact may be mounted on either side (left or right) of the receiver; however, the breechblock contact and the firing pin contact must be assembled on the same side of the receiver in order to fire the gun.

b. Disassembly of Breechblock Contact Parts (Guns M24 and M24E2) (fig. 96).

Note. Some early production models of the gun M24A1 use the same breechblock contact parts as guns M24 and M24E2.

- (1) Remove locking wire that secures receiver filler block retainer screw and the breechblock contact cover screw to the connector of the firing cable (fig. 96).
- (2) Remove cable clip screw and lock washer to disconnect firing cable (fig. 97).
- (3) Remove the two breechblock contact cover screws and the four receiver filler block retainer screws (fig. 96).
- (4) Remove receiver filler block retainer, breechblock contact cover, and breechblock contact from outside the receiver and

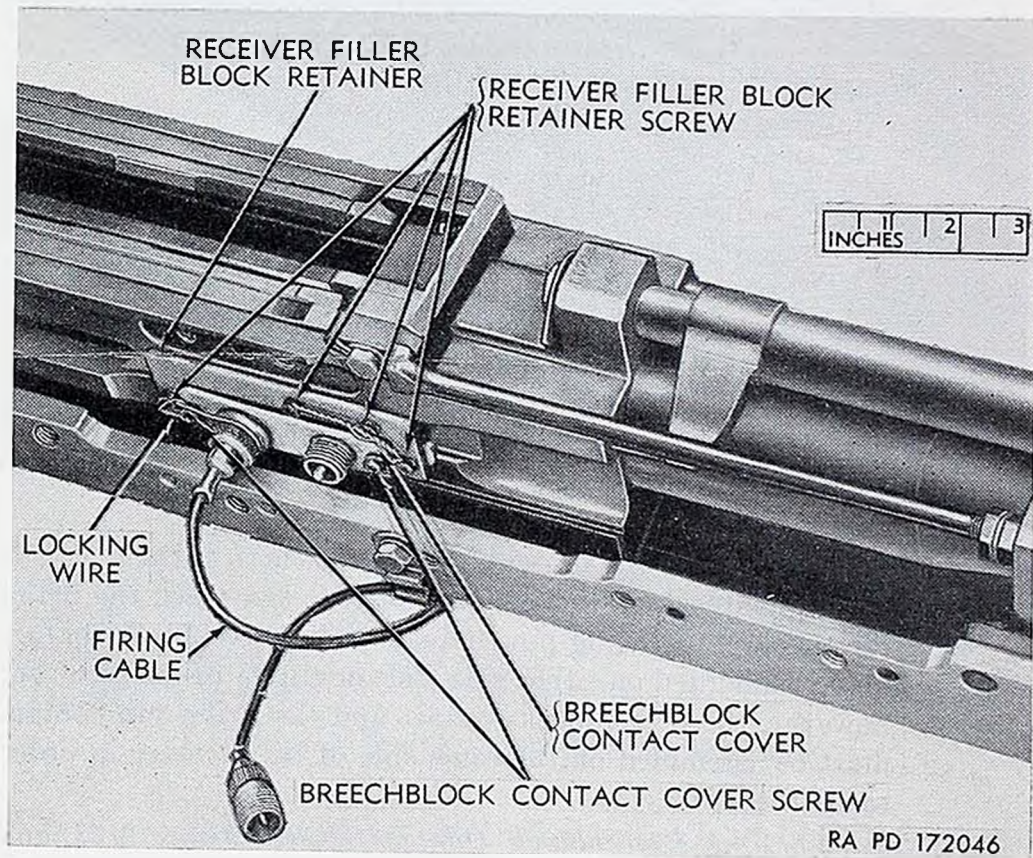

Figure 96. Removing breechblock contact parts.

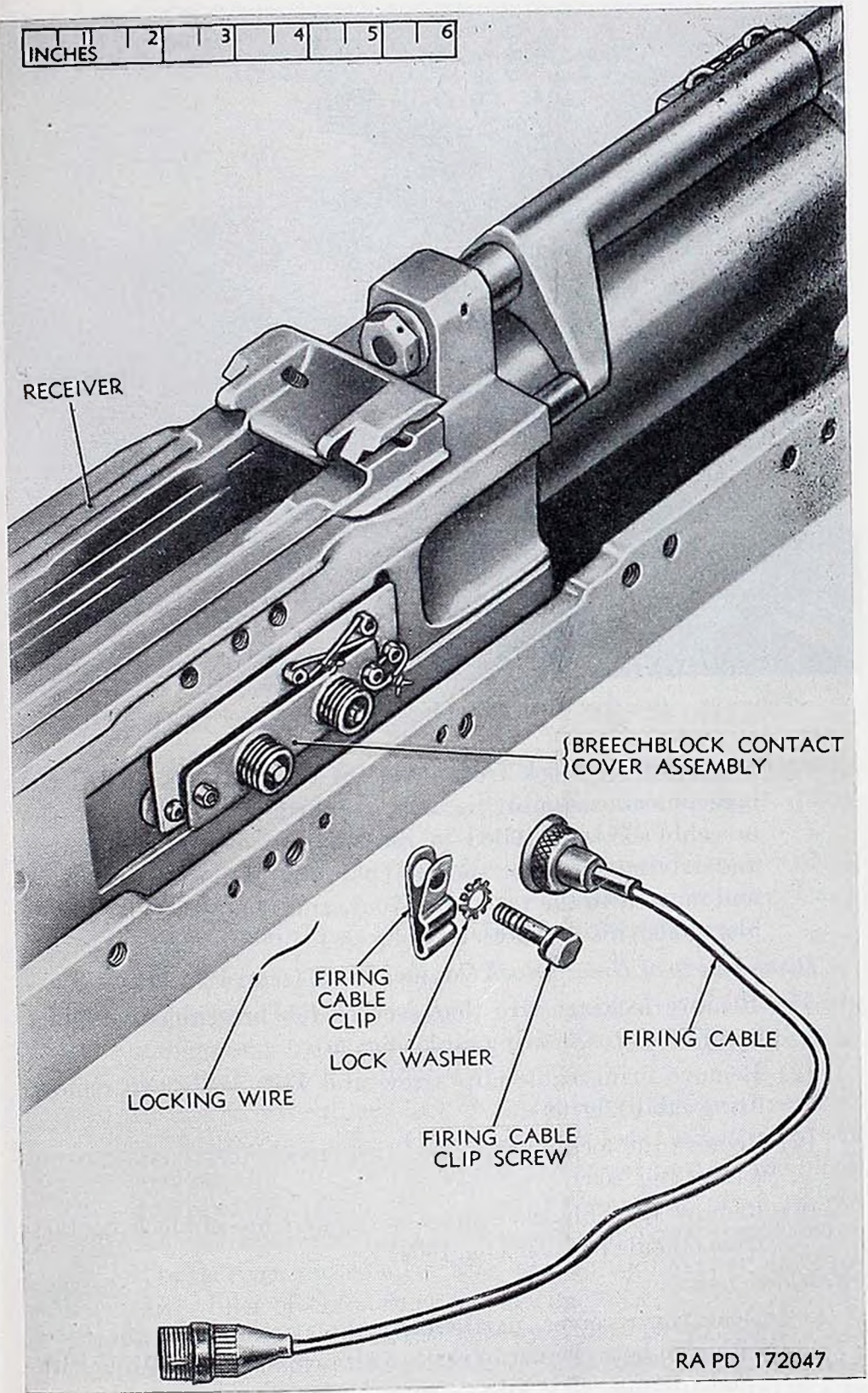

Figure 97. Firing cable and attaching parts.

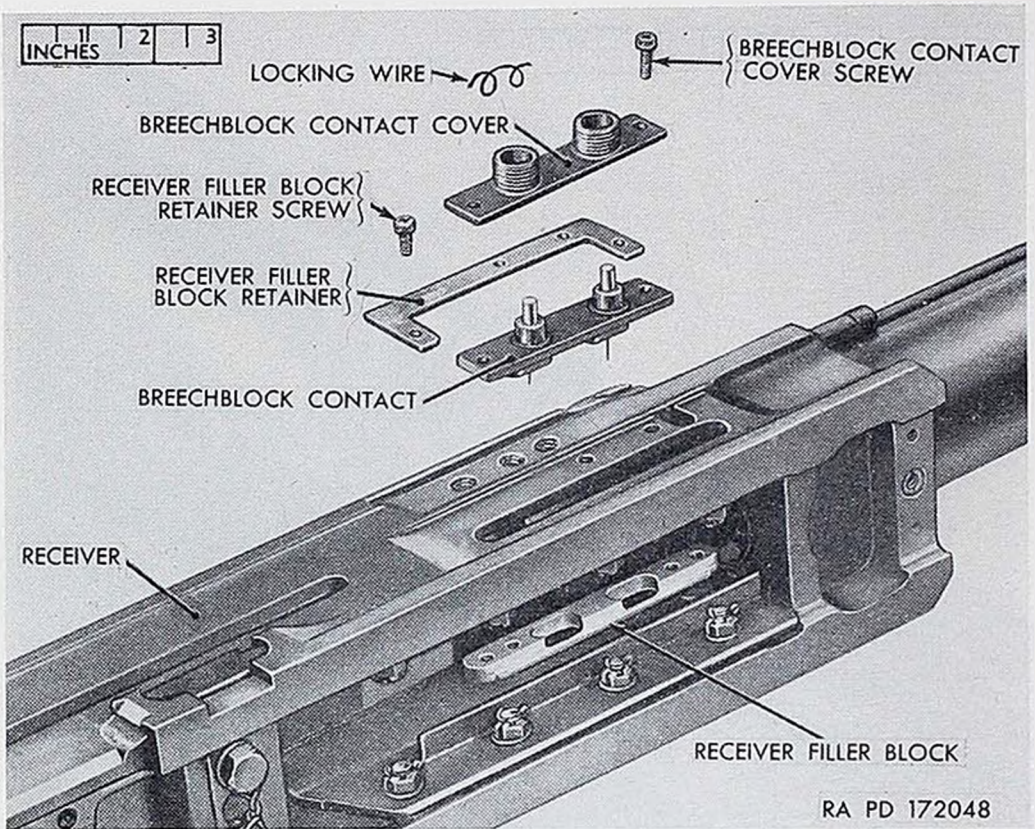

Figure 98. Disassembly of breechblock contact and cover—gun M24.

receiver filler block from inside of receiver (fig. 98), if the breechblock assembly is not installed in receiver; if the breechblock is installed in receiver, remove guide plunger and driving spring or springs (par. 66a), unlock breechblock and move it to the rear (par. 70c), and remove receiver filler block from inside of receiver (fig. 98).

c. Disassembly of Breechblock Contact Parts (Gun M24A1).

- (1) Remove locking wire that secures the breechblock contact cover screw to the firing cable (fig. 99).
- (2) Remove firing cable clip screw and lock washer to remove firing cable (fig. 99).
- (2) Remove the locking wire and two breechblock contact cover screws (fig. 100).
- (4) Remove breechblock contact cover and breechblock contact from outside receiver (fig. 100).

d. Maintenance.

- (1) Clean the receiver, particularly the portion near the tube, with rifle-bore cleaner to remove all primer salts. Wipe with a cloth dampened in oil.

RESTRICTED—Security Information

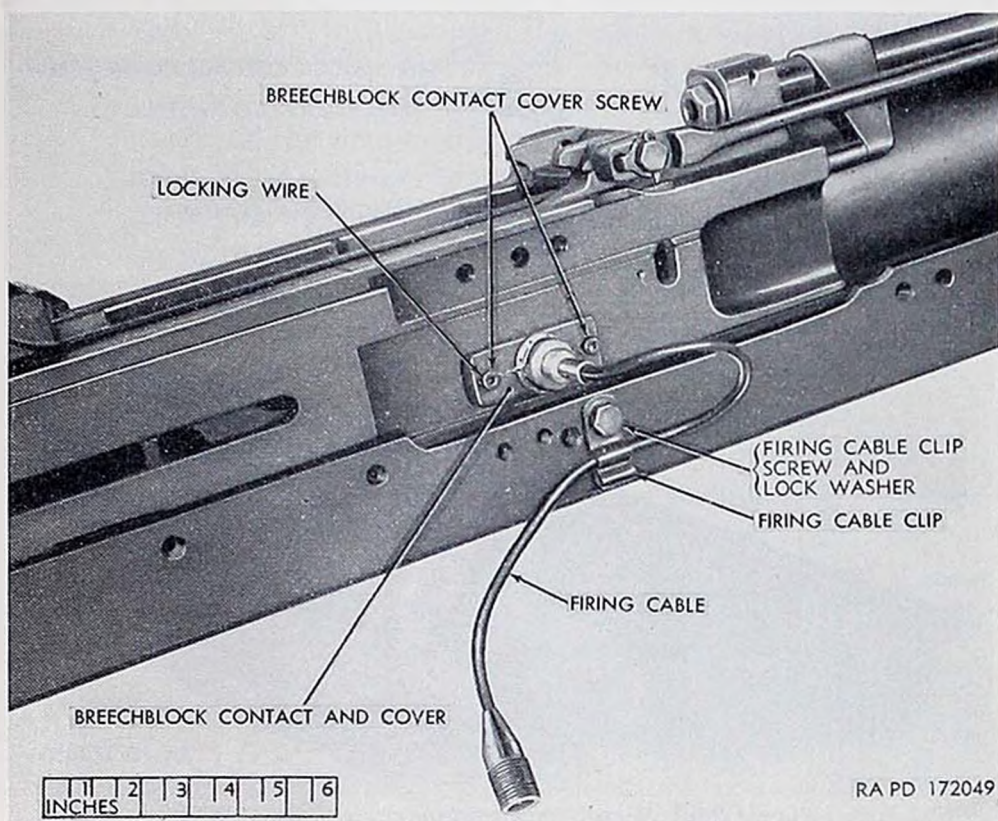

Figure 99. Removing breechblock contact parts—gun M24A1.

- (2) Inspect receiver for cracks, spreading of receiver plates in vicinity of dovetail grooves, dents, and other damage; if any damage is found, notify field maintenance.
 - (3) Examine firing cable for defective insulation, broken wiring, and separation of wiring from connector or ferrule; if any of these conditions exist, notify field maintenance.
- e. *Assembly of Breechblock Contact Parts (Guns M24 and M24E2).*
- (1) If the breechblock is already in the gun, first remove guide plunger and driving spring(s) (par. 66a) and unlock breechblock and move it to the rear (par. 70c).
 - (2) Install receiver filler block in slot through inside of receiver so that the open sides of the filler block face the bottom of the receiver (fig. 101). The upper and lower part of the block should fit neatly into the slot in the receiver.
 - (3) Mount the receiver filler block retainer on receiver and fasten it to receiver and receiver filler block with the four short receiver filler block retainer screws (fig. 98).
 - (4) Assemble breechblock contact cover and breechblock contact to receiver filler block from outside receiver so that the shorter of the two contact wires is toward the rear of the gun

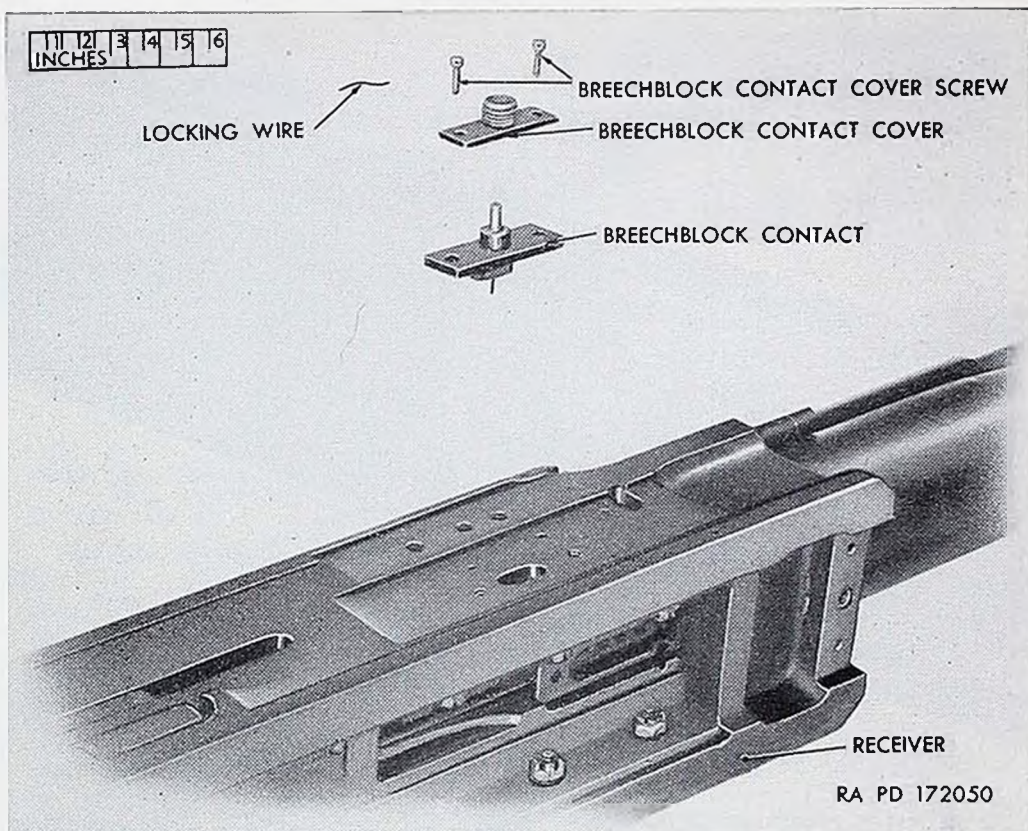

Figure 100. Breechblock contact parts—gun M24A1.

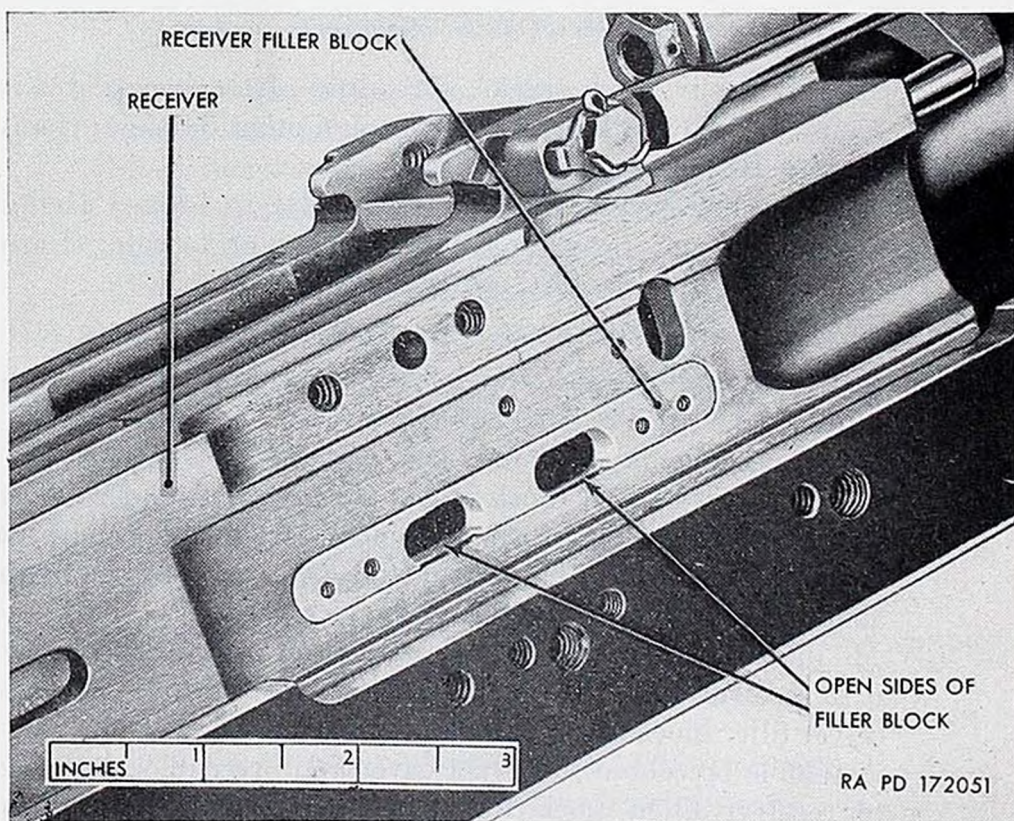

Figure 101. Installation of filler block in receiver.

RESTRICTED—Security Information

and fasten it in place with the two long breechblock contact cover screws (fig. 98).

- (5) Connect firing cable to rear receptacle and secure the connector of the firing cable with locking wire to the receiver filler block retainer screw and breechblock contact cover screw (fig. 96). Secure the four remaining screws with locking wire (fig. 96).
- (6) Adjust cable slack to permit a recoil of $1\frac{1}{8}$ inches and secure firing cable clip to cradle with a cable clip screw and lock washer (fig. 97).

f. Assembly of Breechblock Contact Parts (Gun M24A1).

- (1) If the breechblock is already in the gun, first remove the guide plunger and driving spring or springs (par. 66a) and unlock the breechblock and move it to the rear (par. 70c).
- (2) Secure the breechblock contact and breechblock contact cover to receiver with the two breechblock contact cover screws (fig. 100).
- (3) Connect the firing cable to receptacle and secure the connector of the firing cable and the two breechblock contact cover screws with locking wire (fig. 99).
- (4) Adjust cable slack to permit a recoil of $1\frac{1}{8}$ inches and secure the firing cable clip to the receiver with the firing cable clip screw and lock washer (fig. 99).

82. Magazine Slide

a. General (fig. 102).

- (1) The function of the magazine slide is to hold the feed mechanism in a fixed position with respect to the cradle while the rest of the gun recoils during firing.
- (2) The magazine slide has machined runners on either side that slide back and forth in machined runways on the receiver. There is an upper and a lower set of longitudinal grooves in the magazine slide to house the magazine latch (upper set) and the ejector (lower set).
- (3) Two magazine latch springs fit into the magazine latch and rest against the magazine slide back plate, which is held in place by two magazine slide back plate screws. The springs give tension to the latch, which is held in place by the magazine latch lever. The ball of the lever fits into a countersunk hole in the latch and is secured in place by the magazine latch lever pin, which fits through two lugs on the slide and the lever. The feed mechanism, which is held in place on the

- | | | |
|-----------------------------------|----------------------------|-----------------------------|
| A—COTTER PIN | G—MAGAZINE LATCH SPRINGS | N—MAGAZINE SLIDE |
| B—EJECTOR STUD NUT | H—MAGAZINE LATCH | P—ANCHOR SCREW LOCK WASHER |
| C—MAGAZINE SLIDE BACK PLATE SCREW | J—MAGAZINE LATCH LEVER | Q—ANCHOR SECURING SCREW |
| D—EJECTOR STUD WASHER (FIBER) | K—MAGAZINE LATCH LEVER PIN | R—MAGAZINE SLIDE ANCHOR |
| E—EJECTOR STUD WASHER (STEEL) | L—EJECTOR SPRINGS | S—MAGAZINE SLIDE ANCHOR NUT |
| F—MAGAZINE SLIDE BACK PLATE | M—EJECTOR | T—LOCK WASHER |

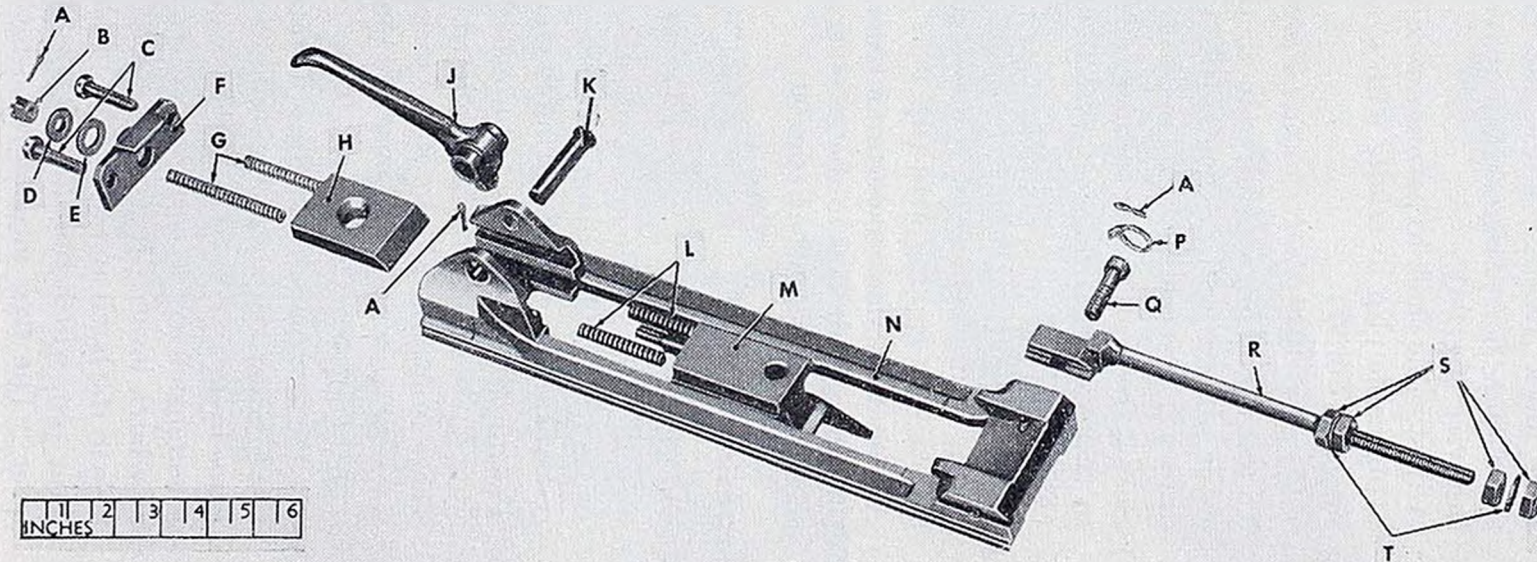

Figure 102. Magazine slide parts.

RESTRICTED—Security Information

slide by two projections on the front, is locked in place at the rear by the magazine latch.

- (4) The ejector, which fits into the lower longitudinal guides, consists of two prongs projecting from a steel plate. The plate houses two springs that contact the magazine slide back plate. A threaded stud, projecting from the rear of the ejector, passes through the backplate, ejector stud fiber washer, and ejector stud steel washer and is secured by the ejector stud nut and cotter pin. The upper, inner surfaces of the prongs are shaped to center the incoming round into the path of the breechblock as it moves forward. The top shoulder of the breechblock moves between the two prongs of the ejector. The prongs deflect the empty cartridge case downward as the breechblock moves to the rear.
- (5) The magazine slide anchor is fastened to the anchor support bracket that is attached to the cradle. It holds the magazine slide stationary while the receiver recoils. This factor is utilized in the operation of the feed mechanism.

b. Removal and Disassembly.

- (1) Remove the two magazine slide anchor nuts and lock washer on the front end of the magazine slide anchor (fig. 102).
- (2) Remove driving spring or springs and rear buffer assembly (par. 66).
- (3) Remove cotter pin that secures ejector stud nut (fig. 103).
- (4) Remove ejector stud nut and the ejector stud nut washers (figs. 103 and 104).
- (5) Remove ejector and ejector springs (fig. 104).
- (6) Remove locking wire and gradually and evenly unscrew magazine slide back plate screws (figs. 102 and 103).
- (7) Remove magazine slide back plate and two magazine slide latch springs (fig. 102).
- (8) Remove cotter pin from magazine latch lever pin, withdraw magazine latch lever pin, and remove magazine latch lever and magazine latch (fig. 102).
- (9) Push magazine slide rearward and off receiver.
- (10) Remove cotter pin, anchor securing screw, and anchor screw lock washer from magazine slide anchor (fig. 102).
- (11) Withdraw magazine slide anchor from magazine slide (fig. 102).

c. Maintenance.

- (1) Check ejector for stripped threads, loose stud, cracks, or fractures; if any of these conditions exist, replace ejector.
- (2) Replace ejector springs if kinked or broken.

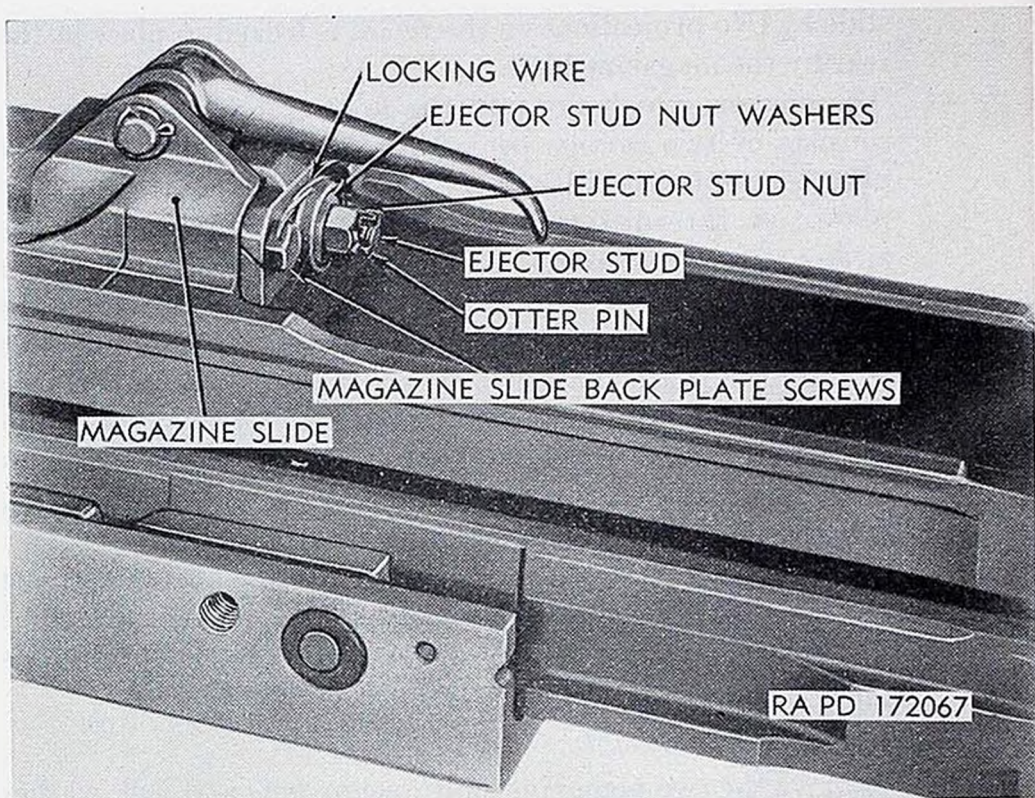

Figure 103. Removal of ejector.

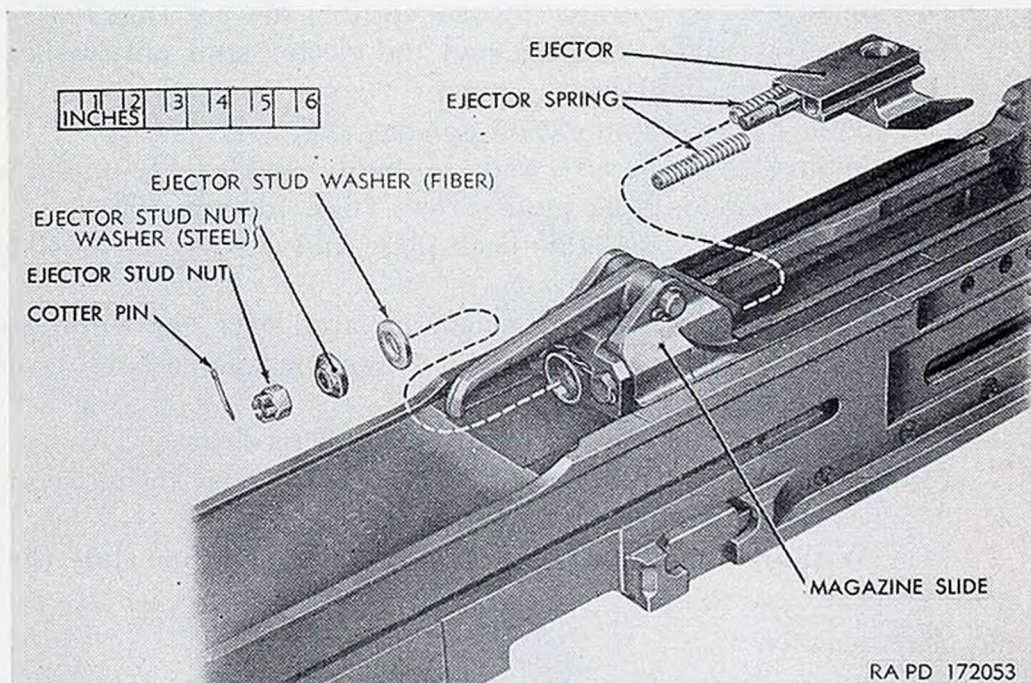

Figure 104. Ejector removed from magazine slide.

RESTRICTED—Security Information

- (3) Replace ejector stud nut if threads are bruised.
- (4) Check magazine slide anchor; if threads are bruised or anchor is bent, replace it.

d. Assembly and Installation.

- (1) Attach magazine slide anchor to magazine slide, with threaded portion of the magazine slide anchor pointing away from the front end of the magazine slide (fig. 102). The magazine slide anchor should be installed on the same side as the anchor support bracket (fig. 32 or 33).
- (2) Install magazine slide anchor securing screw and magazine slide anchor screw lock washer and secure with cotter pin (fig. 102).
- (3) Slide magazine slide, with magazine slide anchor leading, into the guideways of the receiver.
- (4) Place magazine latch in upper grooves on magazine slide, with the angled end pointing toward muzzle of gun, as shown in figure 102.
- (5) Position magazine latch lever so that its ball is in hole in magazine latch, handle of lever points toward rear of gun, and hole in lever aligns with holes in magazine slide (fig. 102). Install magazine latch lever pin and secure it with cotter pin (fig. 102).
- (6) Insert the two latch springs into their seats in rear of magazine latch (fig. 102).
- (7) Place magazine slide back plate flush against latch springs and screw in evenly the two magazine slide back plate screws (fig. 102). Secure the magazine slide back plate screws with locking wire (fig. 103).
- (8) Insert the two ejector springs into their recesses in rear of ejector (fig. 102). Place ejector in the two grooves of magazine latch and slide it to rear until ejector stud protrudes through hole in magazine slide back plate (figs. 102 and 103).
- (9) Place ejector stud fiber washer on ejector stud, with hole bevel toward ejector (outside bevel will then face the rear), follow with ejector stud nut steel washer, and then screw on the ejector stud nut (figs. 102 and 104). Draw stud nut tight, then back it off three-quarters of a turn to prevent the ejector springs from being compressed solidly and to prevent the ejector from piercing the rim of the cartridge during ejection. Secure the ejector stud nut with cotter pin (figs. 103 and 104).
- (10) Install magazine slide anchor front nuts and lock washer on front end of magazine slide anchor (fig. 102).

RESTRICTED—Security Information

83. Recoil Mechanism

The function of the recoil mechanism is to absorb the shock of recoil of the gun and return it into battery. For detailed information on functioning, refer to paragraph 49.

Note. The using organizations are prohibited from disassembling or assembling the recoil mechanism. In case of a malfunction, notify field maintenance.

Section XII. 20-MM MANUAL CHARGER M6

84. General

The 20-mm manual charger M6 is a device for charging the 20-mm automatic gun by hand. Charging is accomplished by pulling the charger cable to move the breechblock to the rear and then allowing it to return by spring action. For detailed explanation of functioning, refer to paragraph 56*a*.

85. Maintenance

- a.* Clean and oil charger weekly and after each firing period.
- b.* The disassembly of the 20-mm manual charger M6 is not within the scope of organizational maintenance. In case of malfunction, notify field maintenance.

Section XIII. 20-MM PNEUMATIC CHARGER M4

86. General

The 20-mm pneumatic charger M4 is an air- or gas-powered mechanism for charging the 20-mm automatic gun. For detailed explanation of functioning, refer to paragraph 56*b*.

87. Maintenance

- a.* Clean and oil charger weekly and after each firing period.
- b.* The disassembly of the 20-mm pneumatic charger M4 is not within the scope of organizational maintenance. In case of malfunction, notify field maintenance.

Section XIV. 20-MM FEED MECHANISMS AN-M2, M2E4, AND M2E5

88. General

a. The 20-mm feed mechanisms AN-M2, M2E4, and M2E5 are complete recoil-operated units designed for feeding belted ammuni-

RESTRICTED—Security Information

tion into 20-mm automatic guns. There are two distinct feed mechanisms for each model—a right-hand feed mechanism that feeds ammunition from the right-hand side and a left-hand feed mechanism that feeds ammunition from the left-hand side.

b. Ammunition can be led into the feed mechanism, through the feed chute adapter, at an angle of 75° above the horizontal on the drive side of the feed mechanism. The mechanism can be fitted with feed covers (feed covers are contractor-furnished Air Force equipment and are not issued by the Ordnance Corps) to give ammunition entrance angles from 55° above the horizontal to 47° below on the drive side of the mechanism. Ammunition belts for this mechanism are made up of 20-mm metallic belt links M10 (M8E1) (fig. 105). A filler piece (fig. 105) is also used (par. 19*d*).

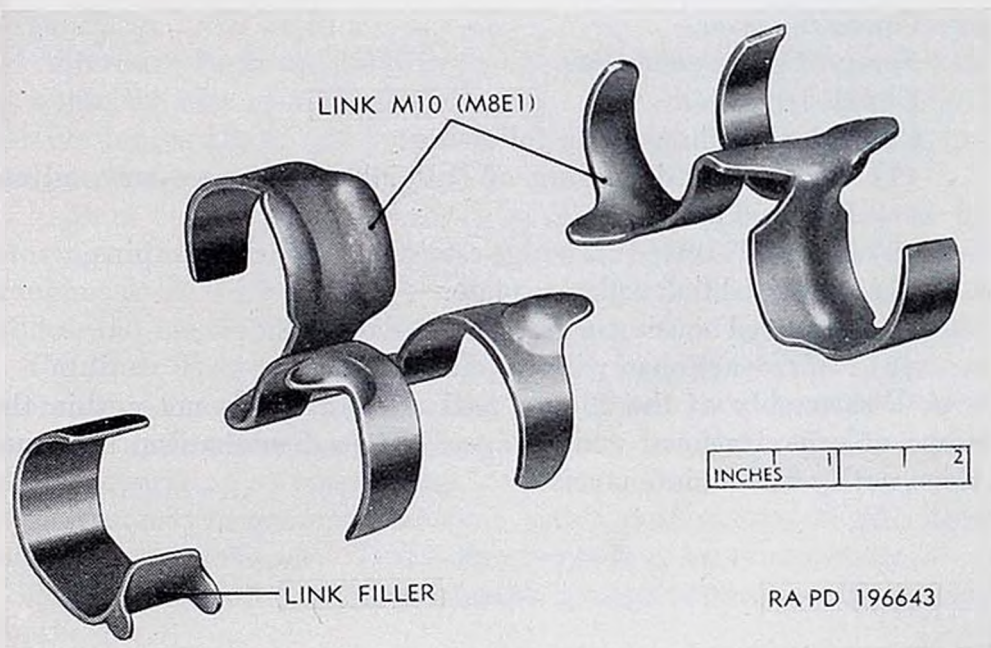

Figure 105. Links M10 (M8E1) for belting ammunition.

c. The feed mechanism, as a whole, is mounted on the magazine slide, which, in turn, is secured to the nonrecoiling cradle. The operating lever bracket (fig. 36), which is secured to the recoiling receiver, actuates the mechanism during recoil and counterrecoil. A recoil distance of $\frac{5}{8}$ to $1\frac{3}{16}$ inches is satisfactory to keep the mechanism in operation.

d. For detailed information on the functioning of the feed mechanisms, refer to paragraph 57; for information on differences between the feed mechanisms, refer to paragraph 4*c*.

89. Maintenance

a. Weekly and after firing, clean all accessible parts with rifle-bore cleaner and then wipe with a cloth dampened with preservative lubricating oil (special).

Caution: Do not dip the complete 20-mm feed mechanism in any cleaning fluid or oil, because such fluids will destroy the lubricant in the mechanism. The driving assembly is lubricated during manufacture and no provision is made for cleaning or lubrication after the assembly is riveted together.

b. Lubricate the following parts with a drop of oil:

Front holding cam.

Rear holding cam.

Cartridge control pawl.

Operating crank bracket.

Operating lever.

Joints of link assemblies.

Clutch driven hubs.

c. Check feed mechanism for following:

(1) Backlash and binding of ball joints. If necessary, adjust link stud plugs.

(2) Lost or distorted cartridge retainer cam springs or pins.

(3) Distorted link deflector plate.

(4) Distorted housing or feed chute adapter.

(5) Positive action of winding clutches.

d. Disassembly of the 20-mm feed mechanisms is not within the scope of organizational maintenance. If feed mechanism malfunctions, notify field maintenance.

CHAPTER 4

FIELD MAINTENANCE INSTRUCTIONS

Section I. GENERAL MAINTENANCE

90. General

a. Field maintenance of the materiel, for the most part, consists of the replacement of unserviceable parts or assemblies. It usually means turn-around maintenance, i. e., repair and return to the using organization. In event the materiel is found unserviceable or signs of failure are disclosed, it will be thoroughly and completely inspected, put into the best possible condition that time, materials, and tactical circumstances allow, and returned to the using organization for immediate use.

b. Burs on components, caused by firing, should be removed by stoning. Burs on working surfaces such as the bolt assembly and roughness on working parts such as breechblock lock, breechblock slides, and inertia blocks should be removed with a fine-grained stone.

Caution: Exercise care to stone evenly, lightly, and not to remove more metal than is absolutely necessary. Parts should not be altered in any way that would make them noninterchangeable or affect their proper operation or functioning.

c. Rust may be generally removed with a cloth moistened with light oil or rifle-bore cleaner. If this does not suffice, use crocus cloth.

d. Clean and oil parts and assemble groups before installing them on the gun.

e. Check AF Form 185 (par. 2*c*) for number of rounds fired.

f. Guns that have been fired 5,000 rounds will be withdrawn from service and tagged for ordnance depot rebuild. Inspectors classifying guns for ordnance depot rebuild will record all deficiencies on AF Form 185 at time of inspection.

91. Field Maintenance Allocation

The publication of these field maintenance instructions is not to be construed as authority for the performance, by field maintenance personnel, of those functions that have been restricted to depot shops and arsenals. Complete disassembly and rebuild of the materiel is re-

RESTRICTED—Security Information

stricted to depot maintenance, which is the responsibility of the Ordnance Corps.

Section II. PARTS, SPECIAL TOOLS, AND EQUIPMENT FOR FIELD MAINTENANCE

92. General

Tools, equipment, and maintenance parts over and above those available to the using organization are supplied to field maintenance units for maintaining and repairing the materiel.

93. Parts

Field maintenance parts are listed in the appropriate column of the Department of Army Supply Catalog ORD 8 SNL A-73, which is the authority for requisitioning replacements. Requisition for ORD 9 parts will contain a complete justification of requirements.

94. Common Tools and Equipment

Standard and commonly used tools and equipment having general application to this materiel are listed in ORD 6 SNL J-8, Section 6 and are authorized for issue by T/O & E. They are not specifically identified in this manual.

95. Special Tools and Equipment

The special tools and equipment given in table IV are listed in Department of the Army Supply Catalog ORD 6 SNL J-12. This tabulation lists only the special tools and equipment necessary to perform the operations described in this chapter. It is included for information only and is not to be used as a basis for requisition.

96. Improvised Tools

Information on the improvised tool, listed in table V and shown in the dimensional detail drawing in figure 107, is furnished to enable field maintenance organizations to fabricate this tool locally if desired. This tool is of considerable value to maintenance organizations engaged in repairing a large number of weapons. However, the tool is not essential for repair or available for issue; the data is furnished for information only.

Table IV.—Special Tools and Equipment for Field Maintenance

Item	Identifying number	References		Use
		Fig.	Par.	
CLAMP, tube, assembly-----	5570632 (41-G-2005)	106, 118	114a	To remove and install tube.
EXTRACTOR, firing pin contact-----	7237734 (41-E-542-750)	85, 106	71d	To remove firing pin contact.
GAGE, tube-----	7246264		115a	To check remaining life of gun tube.
TOOL, breechblock and firing pin spring plug assembling.	7237920	86, 87, 106	71e, 73e, 74a, b, and c	To assemble breechblock and firing pin spring plug.
TOOL, tube lock removing-----	6163764 (41-T-3378-87)	106, 116	114a	To remove tube lock.
WISE, receiver, clamp type-----	41-V-405	106, 118	114a	To clamp receiver while removing and installing tube.
WRENCH, engrs, angle 15°, sq open end, alloy-S, size of opng $\frac{1}{16}$ in, lgh $7\frac{1}{4}$ in.	5206718 (41-W-1209-40)	92, 106	110c, 116e	To remove and install gas cylinder sleeve guide.
WRENCH, rear buffer-----	5570605 (41-W-1990-400)	79, 106	66a, 68e	To remove and install guide plunger.

RESTRICTED

RESTRICTED—Security Information

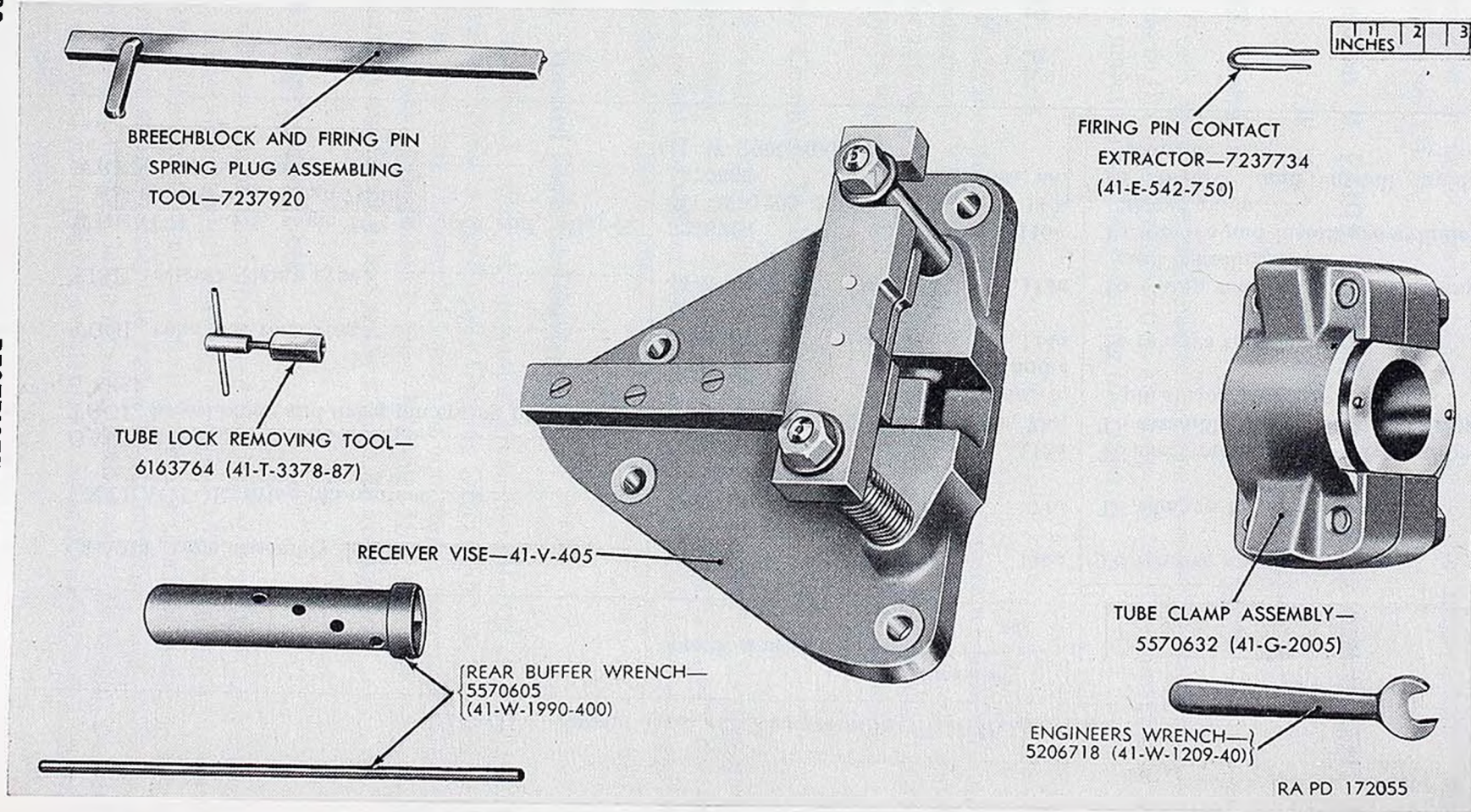
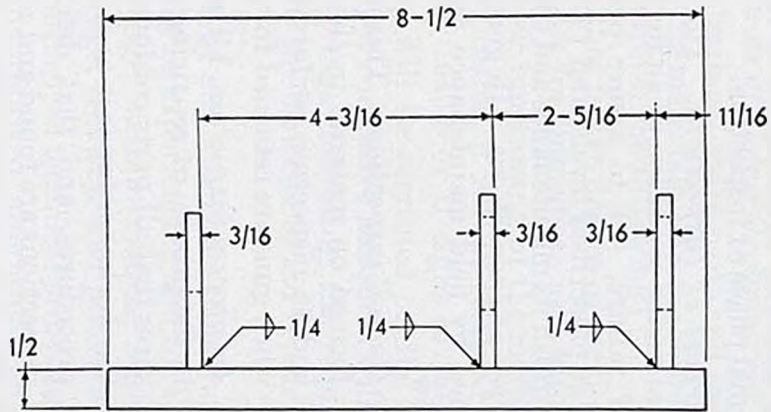
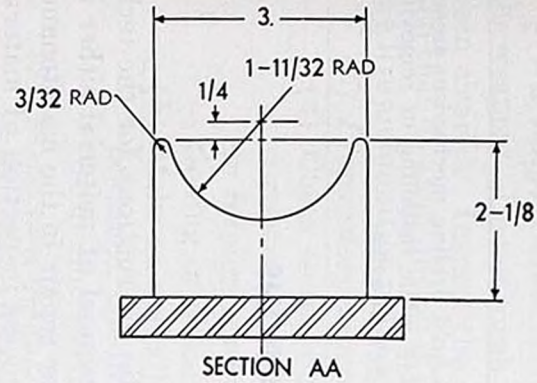
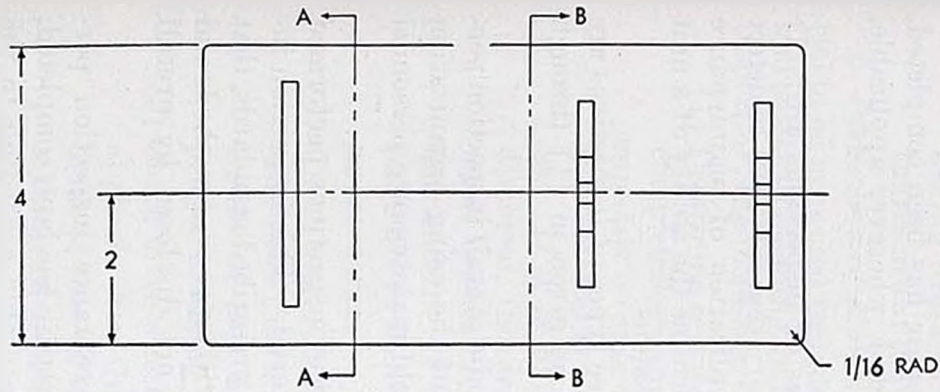
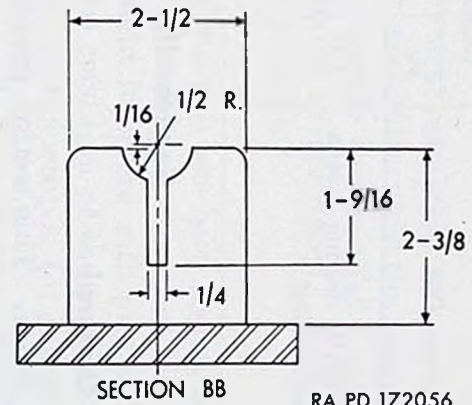

Figure 106. Special tools and equipment for field maintenance.



NOTE: ALL DIMENSIONS SHOWN ARE IN INCHES



RA PD 172056

Figure 107. Improvised driving mechanism holding fixture.

RESTRICTED—Security Information

Table V. *Improvised Tool for Field Maintenance*

Item	References		Use
	Fig.	Par.	
FIXTURE, driving mechanism holding.	107	124g	To hold driving mechanism assembly while installing or removing clutch pocket.

Section III. INSPECTIONS

97. General

a. Scope. This section provides specific instructions for the technical inspection by field maintenance personnel of material either in the hands of the user or when received for repair in the maintenance shops. It also briefly describes the in-process inspection of materiel during repair and final inspection after repair has been completed. Trouble shooting information is incorporated, wherever applicable, as a normal phase of inspection.

b. Purpose of Inspections. The purposes of inspections are: (1) to determine the condition of an item as to serviceability, (2) to detect signs of failure, (3) to assure proper application of maintenance policies at prescribed levels, and (4) to determine the ability of a unit to accomplish its maintenance and supply missions.

c. Types of Inspections. In general, three types of inspections are performed by field maintenance personnel as given in (1) through (3) below.

- (1) *Overall inspection.* This is a periodic overall inspection performed on materiel in the hands of the using organization and an inspection performed by field maintenance personnel when guns are returned for repair.
- (2) *In-process inspection.* These are the inspections performed in the process of repairing the materiel. This inspection insures that all parts conform to the prescribed standards, that the workmanship is in accordance with approved methods and procedures, and that deficiencies not disclosed by overall inspections are found and corrected.
- (3) *Final inspection.* This is an acceptance inspection performed by a final inspector, after repair has been completed, to insure that the materiel is acceptable according to the standards established.

98. Overall Inspection

a. General.

Warning: Before starting a technical inspection, be sure to clear the weapon. Do not touch the firing mechanism until the weapon has been cleared. Inspect the chamber to make certain that it is empty and that no ammunition is in a position to be introduced. Avoid having live ammunition in the vicinity of the work.

(1) *Preparatory procedures.*

(a) Check to see whether the weapon has been cleared of all corrosion-preventive compound, grease, excess oil, dirt, or foreign matter that might interfere with proper functioning or obscure the true condition of the parts.

(b) Make an overall inspection of the weapon for general appearance, condition, operation, and manual functioning. Use dummy cartridges.

(2) *Inspection guide.* Table VI lists the points to be inspected during overall inspection and final inspection and indicates the nature of the checks to be made.

b. Inspection of Materiel in Hands of Using Organization. Materiel to be inspected includes organizational spare parts and equipment and stocks of cleaning and preserving materials. In the course of this inspection, the inspector will accomplish the following:

(1) Determine serviceability, that is, the degree of serviceability, completeness, and readiness for immediate use, with special emphasis on safe and proper functioning of the materiel. If the materiel is found serviceable, it will be retained in service. If it is found unserviceable or if signs of failure are disclosed, the deficiencies will be corrected on the spot or, when applicable, the proper corrective measures will be recommended. If necessary, tags indicating the required repairs are to be attached to the materiel to aid repair by field maintenance.

(2) Check materiel for causes of any mechanical and functional difficulties that the user may be experiencing and for apparent results of lack of knowledge, misinformation, neglect, improper handling and storage, security, and preservation.

(3) Check to see whether all authorized technical orders have been applied. See that no unauthorized alterations have been made or that no work beyond the authorized scope of the unit is being attempted.

(4) Instruct the using personnel in proper preventive maintenance procedures where existing procedures are found inadequate.

RESTRICTED—Security Information

Table VI. Inspection Guide for 20-mm Automatic Guns

Point to be inspected	Overall inspection	Final inspection
FINISH.....	Should be intact, clean, and free from rust.	Should be dull black or gray.
SPRINGS.....	Check for set, kinks, and breaks.	Check for set, kinks, and breaks.
ELECTRICAL CONNECTIONS.	Check for broken insulation, broken wires, separations, and condition of contacts.	Check the electrical firing circuit (par. 17).
REAR BUFFER GUIDE PLUNGER.	Check guide plunger for bends and breaks. Plunger should work freely. Threads should not be mutilated.	Rear buffer assembly should fit snugly, but should not bind.
CRADLE.....	All rivets must be tight. Holes should not be elongated. All rollers should rotate freely and should not be cracked or chipped. Test mounting bracket for tightness (par. 100c).	Check spacing between recoil housing and trunnion blocks (par. 102).
BREECHBLOCK GROUP.	Firing pin hole should not be enlarged or out-of-round. Check right-hand and left-hand receiver slides for contact with breechblock. Check breechblock slides for parallelism. Check bolt for longitudinal cracks.	Breechblock should move freely in receiver.
GAS CYLINDER GROUP.	Assemble gas cylinder sleeve without spring and check for freedom of motion. Guide should have a medium close fit in sleeve. Push rods should move freely in their recesses. Check for gas leak between tube and gas cylinder bracket. Gas cylinder vent plug should be tight.	Measure distance between gas cylinder sleeve and push rods (par. 111f). Diameter of gas vent hole should not exceed 0.092 inch. Check clearance between hex shoulder of gas cylinder and top of tube (par. 116e).
RECOIL MECHANISM. RECEIVER AND TUBE.	Any damaged parts should be replaced. Check for cracks, spreading of receiver plates in vicinity of dovetail grooves, dents or other damage. Check tube for pastilles or fouling.	Gun should recoil about 1 inch. All parts should function properly in grooves and slides of receiver. Fine pits in tube are allowable.

RESTRICTED—Security Information

- (5) Check completeness of organizational maintenance allowances and procedures for obtaining replenishments.
- (6) Check condition of storage of general supplies and ammunition.
- (7) Initiate a thorough report on materiel awaiting repair, with reasons therefor, for further appropriate action.
- (8) Report to the responsible officer any carelessness, negligence, unauthorized alterations, or tampering that may be discovered during the inspection. This report should be accompanied by recommendations for correcting the unsatisfactory conditions.

c. Inspection of Materiel in Field Maintenance Shops. During the course of this inspection, the inspector will accomplish the following:

- (1) Determine serviceability, that is, the degree of serviceability, completeness, and readiness for use, with special emphasis on safe and proper functioning of the materiel.
- (2) Pay particular attention to tagged materiel in order to determine the accuracy of the information on the tag so that corrective action can be initiated.
- (3) Check on application of all authorized technical orders and see that no unauthorized alterations have been made.
- (4) Check all points listed in table VI.
- (5) Perform trouble shooting, as required, using table VII as a guide.

Table VII. Trouble Shooting

Malfunction	Probable causes	Corrective action
Failure to fire chambered round.	Defective primer-----	Remove round.
	Broken, deformed, or burred firing pin.	Replace firing pin (pars 70, 71, 73, 74) or stone off burs.
	Broken firing pin guide-----	Replace firing pin guide (pars. 70, 71, 73, 74).
	Broken breechblock slide key.	Replace breechblock slide plate assembly (pars. 70, 71, 73, 74).
	Broken driving spring or springs.	Replace driving spring or springs (pars. 66 and 68).
	Failure of guide plunger-----	Replace guide plunger (pars. 66 and 68).
	Broken firing circuit in gun. Broken or deformed breechblock contact wires.	Check firing circuit (par. 17). Adjust wires, if possible, or replace breechblock contacts (par. 81).
Defective firing pin contact.	Replace firing pin contact (pars. 70, 71, 73, 74).	

RESTRICTED—Security Information

Table VII. *Trouble Shooting*—Continued

Malfunction	Probable causes	Corrective action
Failure to fire chambered round—Con.	Defective firing cables-----	Check all cables and replace, if necessary (par. 81).
	Loose gas cylinder bracket plug.	Replace with new type plug (pars. 76 and 78) or adjust (par. 109).
Failure to feed-----	Failure of power supply-----	Correct failure.
	Improper adjustment of magazine slide.	Adjust correctly (par. 21b (9)(f)).
	Broken components of magazine slide.	Replace broken parts (par. 82).
	Insufficient recoil of breechblock due to faulty ammunition.	Replace ammunition.
	Broken belt or belt jam----	Check ammunition box and feed chute.
	Broken links or link jam---	Replace defective links.
	Deformed or burred feed mouth.	Stone burs or replace feed mechanism.
	Excessive friction in feed mechanism.	Check movement of parts and lubricate (par. 89a and b).
	Loss of tension in driving spring of feed mechanism.	Replace (pars. 124, 125, 127, and 128).
	Loss of pins (AN-M2) or screws (M2E4 and M2E5) in clutch driven hubs of feed mechanism.	Replace pins and stake in position (pars. 124 and 127) or replace screws (pars. 125 and 128).
	Broken feed mechanism drive clutch springs.	Replace (pars. 124, 125, 127, and 128).
	Frozen front end bearing of feed mechanism.	Free and replace (pars. 124, 125, 127, and 128).
	Improper adjustment of feed chute.	Adjust properly (par. 23a).
Failure to extract---	Broken extractor-----	Replace extractor (pars. 70, 71, 73, 74).
	Broken extractor spring----	Replace extractor spring (pars. 70, 71, 73, 74).
	Broken extractor pin-----	Replace broken extractor pin (pars. 70, 71, 73, 74).
	Dirty or improperly lubricated ammunition.	Remove spent round.
Failure to eject-----	Improper lock clearance----	Adjust (par. 117).
	Broken ejector stud or ejector.	Replace ejector (par. 82).
Runaway gun-----	Defective firing switch-----	Release firing switch.

RESTRICTED—Security Information

Section IV. CRADLE GROUP

99. Removal and Disassembly

a. Remove firing cable clip with firing cable from cradle by removing firing cable clip screw and lock washer (fig. 108).

b. Remove the two magazine slide anchor nuts and lock washer from the front end of the magazine slide anchor (fig. 108).

c. Remove the cotter pin and magazine slide anchor screw lock washer (fig. 108). Unscrew magazine slide anchor screw and remove magazine slide anchor support bracket (fig. 108).

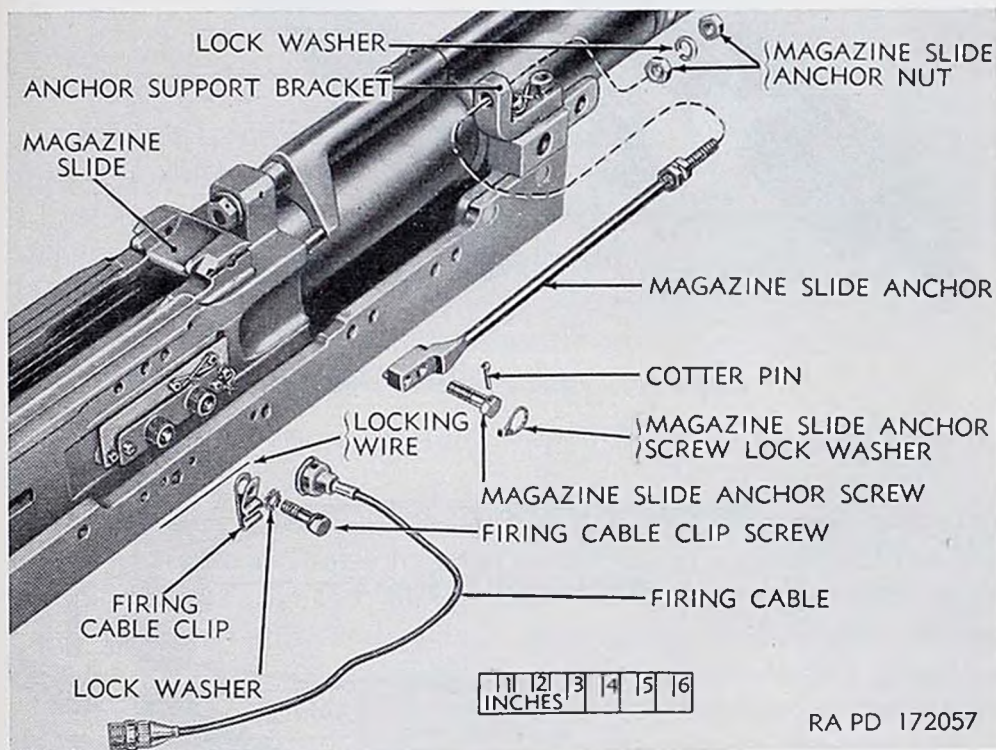

RA PD 172057

Figure 108. Removing cradle from gun.

d. Cut and remove locking wire from the four anchor support bracket screws (fig. 109). Unscrew the screws and lift off anchor support bracket (fig. 109).

e. Raise front end of gun and remove the two trunnion blocks (fig. 109).

f. Move gun forward in cradle until cradle mounting rollers (fig. 110) are disengaged from the cradle mounting plate (fig. 109) and lift gun off cradle. Remove tube trunnion shims (fig. 109) from trunnions and carefully note the quantity on each side.

Caution: These shims should be installed in their original position when assembling the gun.

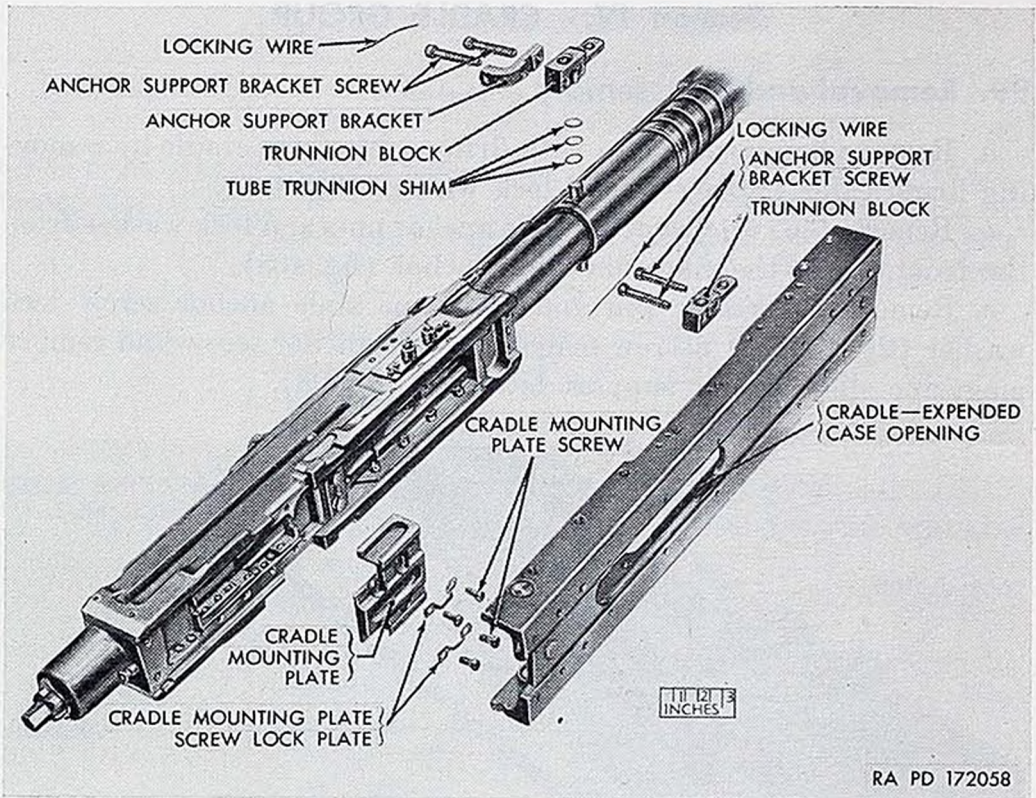

Figure 109. Cradle removed from gun.

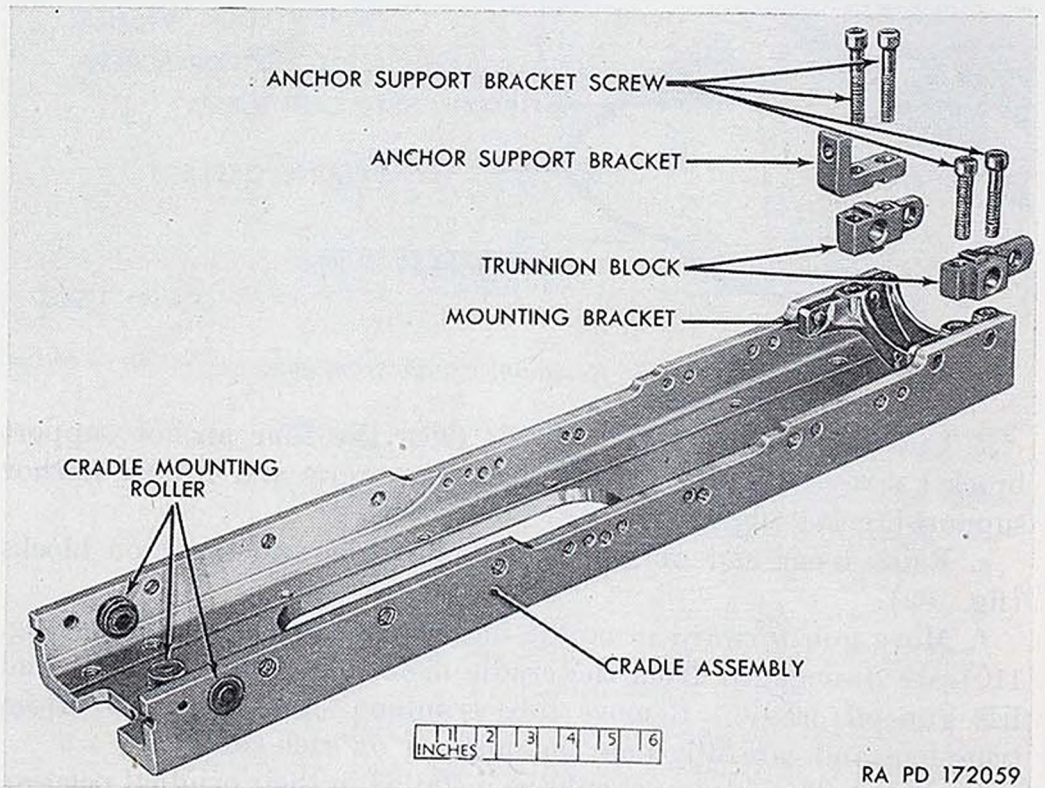

Figure 110. Parts of cradle.

RESTRICTED—Security Information

100. Maintenance

a. Check the cradle for damage or loose parts. Loose parts cause the mounting holes to become elongated and render the cradle useless for further service. Should the holes in the cradle become elongated, the cradle must be replaced.

b. Check cradle mounting rollers for chips and cracks and make certain that rollers rotate freely. If rollers bind or do not rotate freely or are chipped or cracked, replace cradle.

c. Check cradle mounting bracket and all rivets for tightness by tapping either end of cradle mounting bracket a light blow with a hammer. If cradle bracket assembly appears to be loose, replace cradle.

d. Check expended case opening for burs.

e. Inspect trunnion blocks and screws for wear and damage and replace if necessary.

f. Note if pertinent modifications are complete. Cradle for gun M24A1 should have case opening of $10\frac{5}{8}$ inches. Refer to TO 01-5EU-149.

101. Assembly and Installation

a. Install tube trunnion shims (fig. 109) in original position on trunnions.

b. Engage cradle mounting plate of gun with the cradle mounting rollers of cradle and raise forward end of gun enough to slide the two trunnion blocks (fig. 110) on the trunnions and lower forward end of gun. The lugs on the underside of the trunnion blocks should engage the slots in the cradle mounting bracket and the drilled flange on the trunnion block should point toward the muzzle end of the gun. Install the four anchor support bracket screws and tighten by hand; they should be slightly loose to permit adjustment of the spacing between the recoil housing and the trunnion blocks. This adjustment must be made whenever the trunnion blocks and shims are removed; refer to paragraph 102 for the procedure.

c. After adjustment, remove two screws from left or right trunnion block and position the anchor support bracket on trunnion block, with vertical arm on bracket to the rear of the trunnion block. Install the two screws. Tighten the four anchor support bracket screws and wire them with locking wire (fig. 109).

d. Slide the threaded end of the magazine slide anchor forward through the hole in the vertical arm of the anchor support bracket and position rear end of anchor in groove in magazine slide (fig. 108).

RESTRICTED—Security Information

Install the two magazine slide anchor nuts and lock washer (fig. 108) between them.

e. Attach the firing cable with the firing cable clip to the cradle by means of the firing cable clip screw and lock washer (fig. 108). Allow $1\frac{1}{8}$ inches of slack in firing cable for recoil action.

102. Adjustment

Whenever the trunnion blocks and trunnion block shims are removed, it is necessary to adjust the spacing between the recoil housing and the trunnion blocks. Proceed as follows:

a. Secure gun cradle firmly to a bench.

b. Loosen screws slightly (if this has not been done previously).

c. Pull muzzle end of tube to the left side to produce as much clearance as possible between trunnion block and recoil housing. The same results may be obtained by prying against the tube with a large screw driver inserted between the cradle and the tube, slightly to the rear of the trunnion block (fig. 111).

Caution: Be careful not to mar finish of gun.

d. Place a feeler gage between recoil housing and right-hand trunnion block (fig. 111) and measure distance between them.

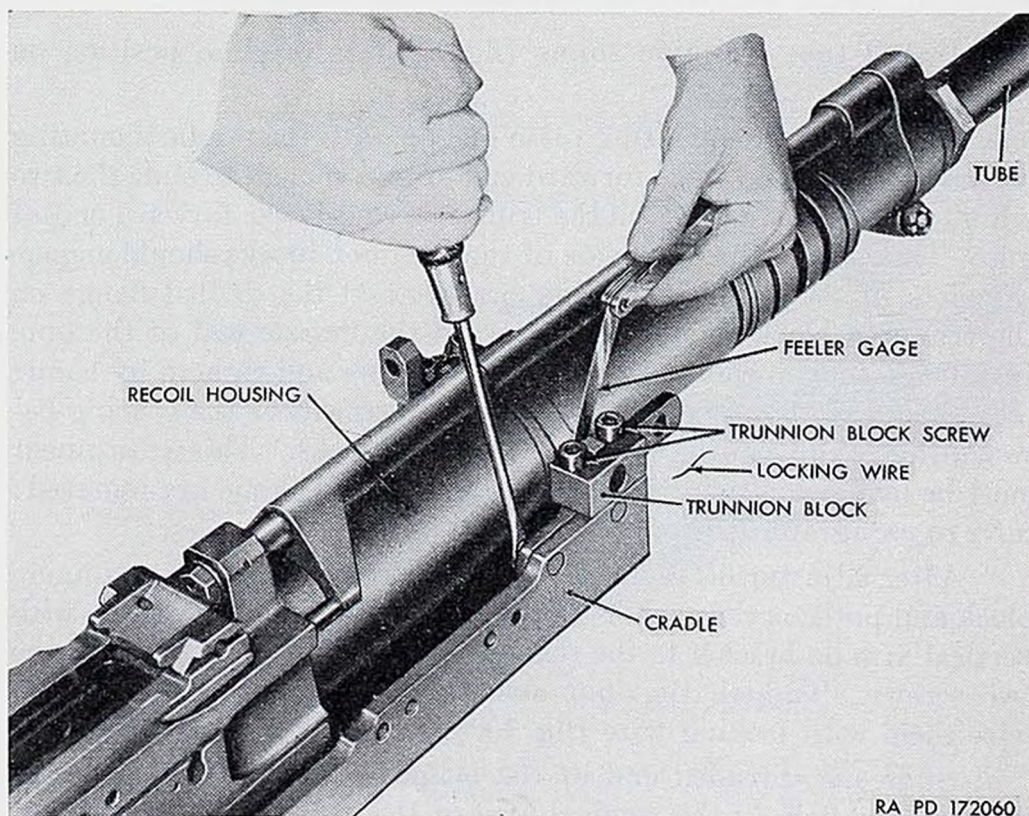

Figure 111. Measuring distance between recoil housing and trunnion block.

RESTRICTED—Security Information

e. In the same manner, measure distance between recoil housing and left-hand trunnion block.

f. Remove the four anchor support bracket screws, anchor support bracket, and trunnion blocks and insert shims, as necessary, to eliminate clearance. Divide shims as evenly as possible between right-hand and left-hand trunnion blocks.

g. Install trunnion blocks, anchor support bracket, and the four anchor support bracket screws. Tighten the four anchor support screws and secure them with locking wire.

Section V. BREECHBLOCK GROUP

103. Disassembly

Note. For removal and disassembly of breechblock group, refer to paragraphs 70 and 71.

a. Removal of Breechblock Bolt Retainers (fig. 112).

Note. Normal maintenance should not require removal of the breechblock bolt retainers. If they are removed for any reason, care should be exercised to insure that both springs (inner and outer) are inserted and that the retain-

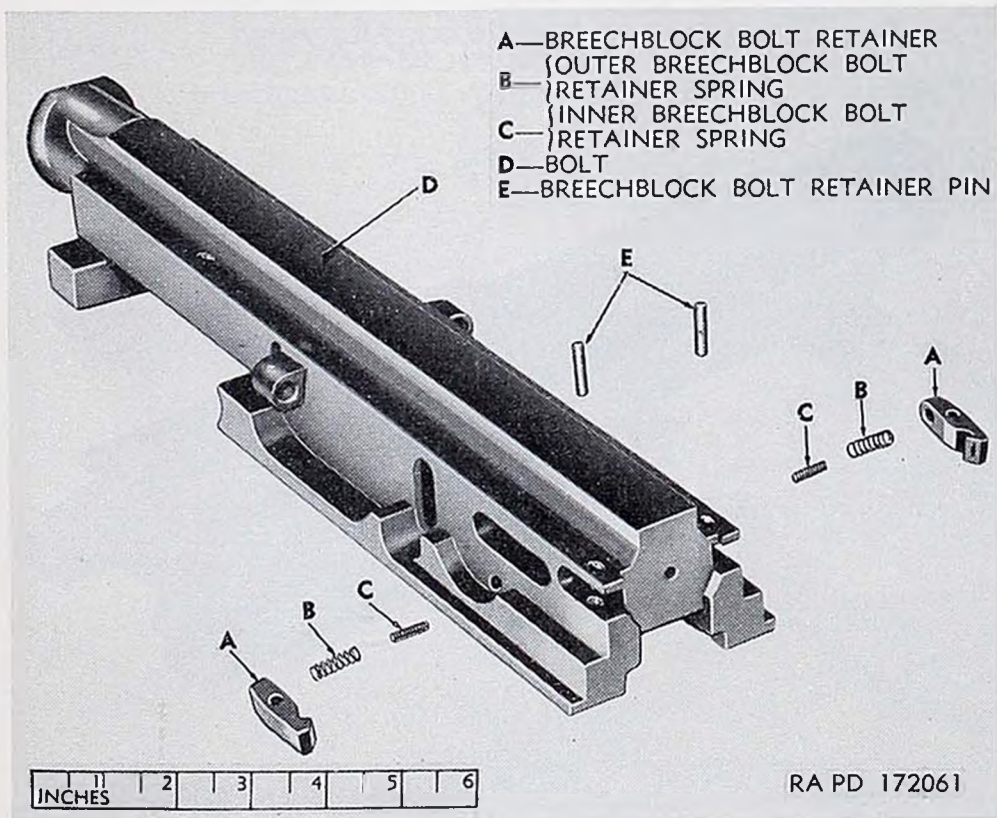

Figure 112. Removal of breechblock bolt retainers.

RESTRICTED—Security Information

ing pin is staked only on the upper surface of the bolt in the rear of the retaining pin hole. It was found that staking the portion of the bolt to the front of the pin hole sometimes started cracks. In early production of guns M24A1, breechblock bolt retainer pins were staked at both ends, while in present production, the pins are staked at upper end only.

- (1) Remove left-hand bolt retainer pin from bolt with a drift punch. Pin should be driven out from lower end of bolt as it is staked on the upper end. Some early production models are staked at top and bottom.
- (2) Remove left-hand bolt retainer carefully so that inner and outer bolt retainer springs will not fly out. Remove inner and outer bolt retainer springs.
- (3) Repeat operations in (1) and (2) above to remove right-hand bolt retainer.

b. Removal of Breechblock Slide Spring Guide Pin (fig. 113).

- (1) Remove breechblock slide spring guide pin retaining pin and bolt with a drift punch. Pin should be driven from bottom of bolt as it is staked in position on top side.
- (2) Withdraw breechblock slide spring guide pin.

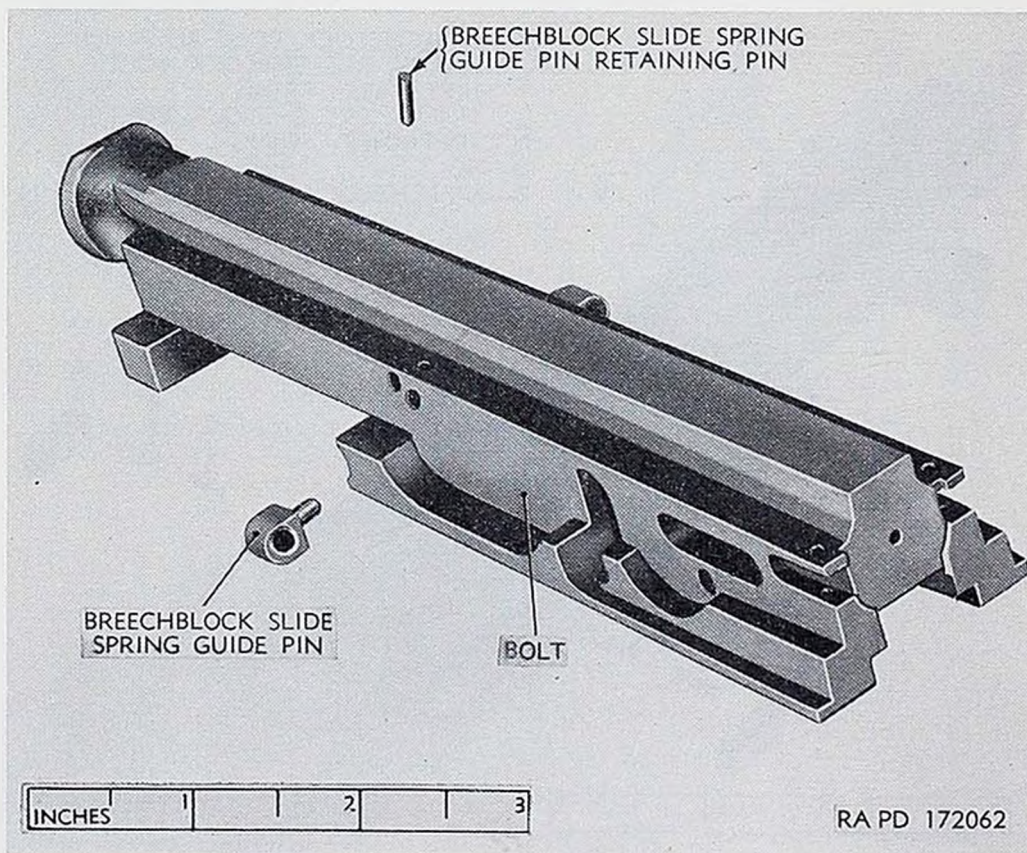

Figure 113. Removal of breechblock slide spring guide pin.

RESTRICTED—Security Information

- (3) Repeat operations in (1) and (2) above to remove right-hand breechblock slide spring guide pin.

104. Maintenance

- a. Check freedom of movement of breechblock in receiver.
- b. Check for cracks on longitudinal shoulders of bolt; inspect, particularly, area over retainers. If shoulders are cracked, replace bolt.
- c. Remove all burrs or rough surfaces from camways of breechblock slide. Check for cracks around cam surface.
- d. Check for free movement of firing pin in guide and of guide in bolt. Be sure that insulation is in visibly good condition. Examine firing pin for deformation and replace if bent or broken. Segregate firing pins 7238051 in accordance with instructions in figure 114. Examine guide outer sleeve and inner bushing for cracks or breaks. Replace the guide if cracked or broken.
- e. Remove any burrs or rough spots from inertia blocks. Be sure of free movement of blocks in breechblock slides.
- f. Examine breechblock lock for cracks and marred surfaces.
- g. Inspect breechblock slides for cracks and marred surfaces; be sure that insulation in right breechblock slide plate assembly is not defective.
- h. Check breechblock slide springs manually. If available, use

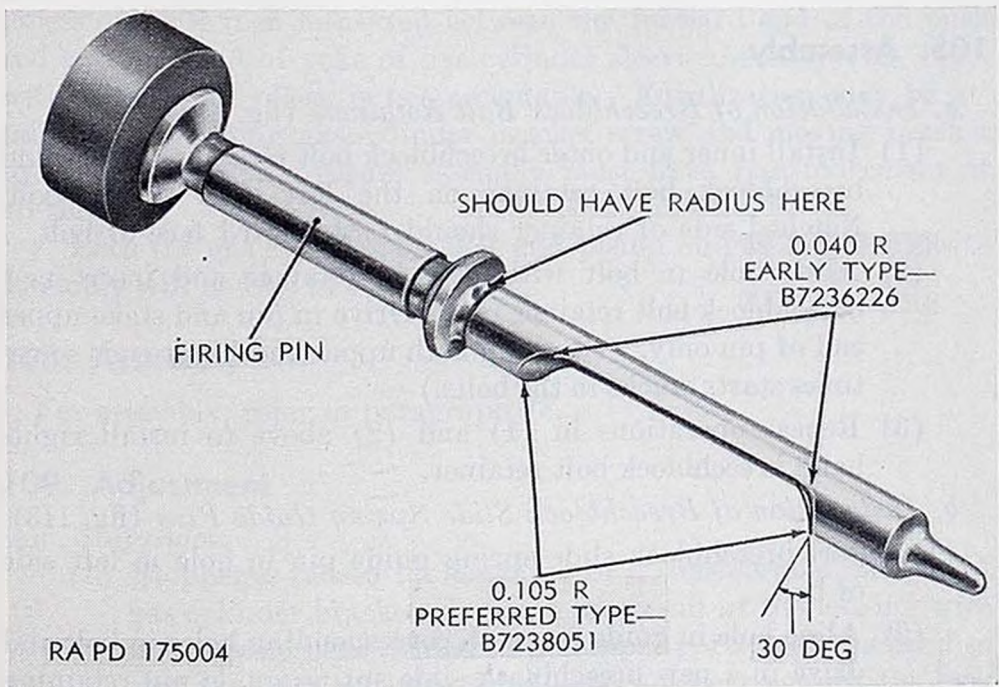

Figure 114. Firing pins.

RESTRICTED—Security Information

only spring 7238276 and corresponding guide 7238262, which is smaller in diameter.

i. Manually check tension of breechblock bolt retainer springs, with retainers assembled to bolt. If springs are weak, replace bolt if available; if bolt is not available, springs will be replaced by A and E maintenance squadron.

j. Check breechblock slide spring guide pins for distortion, which may have been caused by accident in assembling firing pin spring plug pin.

k. Inspect extractor spring for set and deformation of ends. Spring can be checked for set by rolling on a flat surface and noting movement.

l. Inspect firing pin spring plug to be sure that insulation is not broken or in poor condition.

m. Check extractor pin to be sure that it is not battered or deformed.

n. If available, extractor 7305899 will be used in all cases; all early type extractors will be disposed of by transfer to salvage.

o. If available, use only breechblock 7306114. This lock is 0.005 inch longer than lock 7319407 to eliminate line contact on key.

p. Check firing pin spring for distortion.

q. Check breechblock slide spring guides for distortion.

r. Visually check condition of insulation on firing pin contact. Contact should not be burred or bent. Contact 7238311 is preferred; contacts 7237627 and 7231219 are usable.

105. Assembly

a. Installation of Breechblock Bolt Retainers (fig. 112).

- (1) Install inner and outer breechblock bolt retainer springs and breechblock bolt retainer on the left side of the bolt. Notched side of retainer should face toward face of bolt.
- (2) Aline hole in bolt with hole in retainer and insert new breechblock bolt retainer pin. Drive in pin and stake upper end of pin only. (Staking both upper and lower ends sometimes starts cracks in the bolts.)
- (3) Repeat operations in (1) and (2) above to install right-hand breechblock bolt retainer.

b. Installation of Breechblock Slide Spring Guide Pins (fig. 113).

- (1) Insert breechblock slide spring guide pin in hole in left side of bolt.
- (2) Aline hole in guide pin with corresponding holes in bolt and drive in a new breechblock slide spring guide pin retaining pin. Stake pin in position on upper part of bolt.

RESTRICTED—Security Information

- (3) Repeat operations in (1) and (2) above to install right-hand breechblock slide spring guide pin.

Note. For assembly and installation of the breechblock group, refer to paragraphs 73 and 74.

Section VI. GAS CYLINDER GROUP (GUNS M24 AND M24E2)

106. Disassembly

For disassembly, refer to paragraph 76.

107. Maintenance

a. Examine all parts for condition. Replace gas cylinder sleeve assembly if it is bent.

b. Check gas cylinder sleeve spring; if it is kinked or set, replace it.

c. Check action of gas cylinder sleeve guide. The guide should have a reasonably close (medium) fit in sleeve. It is expected that this part will have a longer life than the receiver.

d. Check cylinder end of gas cylinder sleeve assembly for burrs. Remove burrs with a fine stone. If it is too rough, replace the gas cylinder sleeve assembly.

e. Check for free movement of push rods in receiver. Replace any push rods showing evidence of peening. A variation of clearance in excess of 0.004 inch measured between the forward end of the push rod and rear end of yoke of gas cylinder sleeve assembly (fig. 115), with the bolt in place, is not acceptable. Equalization may be attained by loosening gas cylinder bracket screw and moving bracket to desired location. Sleeve assembly must have free movement at all times.

f. Both the gas cylinder bracket and piston on gas cylinder sleeve assembly will be free of corrosion.

108. Assembly

For assembly, refer to paragraph 78.

109. Adjustment

a. Stoppages.

- (1) Stoppages caused by loosening of a considerable number of gas cylinder bracket plugs are the result of the locking wire hole having been drilled in the upper portion of the head so that the wire, when inserted, does not bear against the lock washer. The washer rises or tilts during firing, causing the

RESTRICTED—Security Information

washer tang to disengage and ride over the locking slot, with consequent loosening and loss of the gas cylinder bracket plug and lock washer.

- (2) Early type gas cylinder bracket plugs have a bevel on the underside of the plug head, which does not permit the locking washer to engage the hex side of the plug. This results in loosening of the plug during firing.

b. Corrective Action. New type gas cylinder bracket plugs have eliminated this trouble. If the new plugs are not available, proceed as follows:

- (1) Examine the gas cylinder bracket plug to determine whether the locking wire hole is in the proper location and whether the bevel on the underside of the plug head allows the lock washer to engage the hex side of the plug.
- (2) If the hole is not properly located, an additional hole should be located and drilled in an adjoining flat on the plug.

Section VII. GAS CYLINDER GROUP (GUN M24A1)

110. Disassembly

Note. It is not usually necessary to disassemble the gas cylinder group in normal maintenance.

a. Install a clamp over rear end of gas cylinder sleeve assembly (fig. 9) to hold gas cylinder sleeve spring while the gas cylinder bracket is removed.

b. Drive out spring pin (fig. 9) that is generally staked in position.

c. Unscrew gas cylinder guide, using engineers wrench 5206718 (41-W-1209-40) (figs. 92 and 106).

d. Remove cotter pin, gas cylinder bracket screw nut, and gas cylinder bracket key from gas cylinder bracket (fig. 9).

e. Remove gas cylinder bracket nut (fig. 9) from tube.

f. Remove clamp from rear end of gas cylinder sleeve assembly and remove gas cylinder sleeve assembly (fig. 9).

g. Remove push rods (fig. 9) from recesses in front face of receiver.

Note. Some early production models of gun M24A1 used the old-type gas cylinder bracket that requires a special lock washer to secure it in position.

111. Maintenance

a. Examine all parts for condition. If gas cylinder sleeve assembly is bent, replace it.

b. Replace gas cylinder sleeve spring if it is kinked, set, or broken.

c. Remove all carbon and other foreign matter from gas cylinder sleeve assembly. Remove any small burrs from plug at end of sleeve

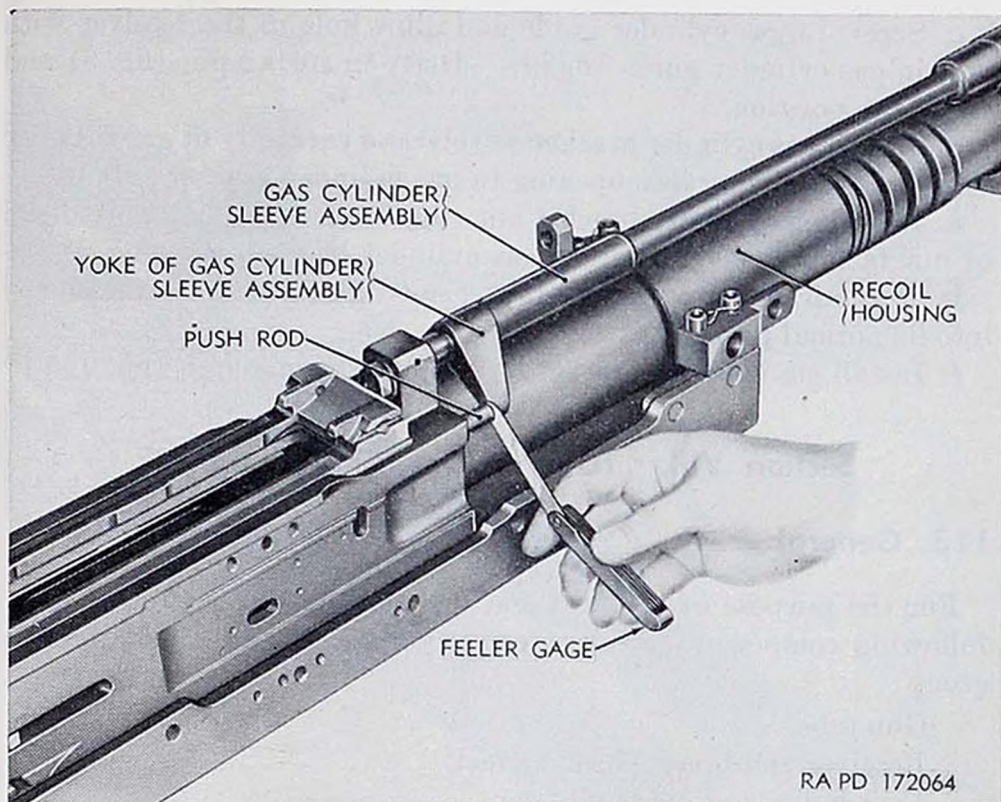

Figure 115. Measuring clearance between push rods and yoke.

assembly. If it is burred excessively, replace assembly and gas cylinder bracket.

d. Check action of gas cylinder sleeve guide in gas cylinder sleeve assembly. Guide should have a reasonably close (medium) fit in sleeve. It is expected that this part will have a longer life than the receiver.

e. Check movement of gas cylinder sleeve plug and ring in gas cylinder bracket. If fit is poor, replace with new parts.

f. Check movement of push rods in receiver. Remove all burs from push rods. Replace any push rods showing evidence of peening. A variation of clearance in excess of 0.004 inch measured between the forward end of the push rod and rear end of yoke of gas cylinder sleeve assembly (fig. 115), with the bolt in place, is not acceptable. Equalization may be attained by loosening gas cylinder bracket screw and moving bracket to desired location. Sleeve assembly must have free movement at all times.

112. Assembly

a. Fit push rods (fig. 9) into recesses in front face of receiver.

b. Install gas cylinder sleeve spring into gas cylinder sleeve assembly (fig. 9) and position sleeve on gun.

RESTRICTED—Security Information

c. Screw in gas cylinder guide and aline hole in the receiver with hole in gas cylinder guide (fig. 9). Drive in spring pin (fig. 9) and stake it in position.

d. Install gas cylinder bracket on tube and carefully fit gas cylinder sleeve plug and ring into opening in gas cylinder bracket (fig. 9).

e. Install gas cylinder bracket nut (fig. 9) on tube, with slotted end of nut facing receiver. Insert gas cylinder bracket key (fig. 9) upside down, draw gas cylinder bracket nut tight, and then reverse key into its normal position.

f. Install gas cylinder bracket screw nut and cotter pin (fig. 9).

Section VIII. TUBE AND RECEIVER GROUP

113. General

For the purpose of removal and disassembly, inspection, etc., the following components are treated as part of the tube and receiver group:

- Gun tube.
- Receiver and breechblock contact.
- Rear buffer and guide plunger.
- Magazine slide.
- Recoil mechanism.

114. Removal and Disassembly

a. Removal of Tube From Receiver.

Note. The tube is to be removed from the receiver only for replacement.

- (1) Remove cradle from receiver (par. 99). Remove cotter pin from tube locking pin in receiver (fig. 117).
- (2) To remove tube locking pin, using tube locking pin removing tool 6163764 (41-T-3378-87) (figs. 106 and 116), screw threads on shaft of tool into tube locking pin as far as they will go, screw large nut on tool downward so that it is flush with the receiver and handtight, and continue to turn nut in same direction with a wrench, while holding the handle of the tool with the other hand. Remove tube locking pin (fig. 117).
- (3) Fasten receiver in receiver vise 6536367 (41-V-405) (figs. 106 and 118), which should be bolted to a bench.
- (4) Install tube clamp assembly 5570632 (41-C-2005) (figs. 106 and 118) over tube, as close to receiver as possible.

RESTRICTED—Security Information

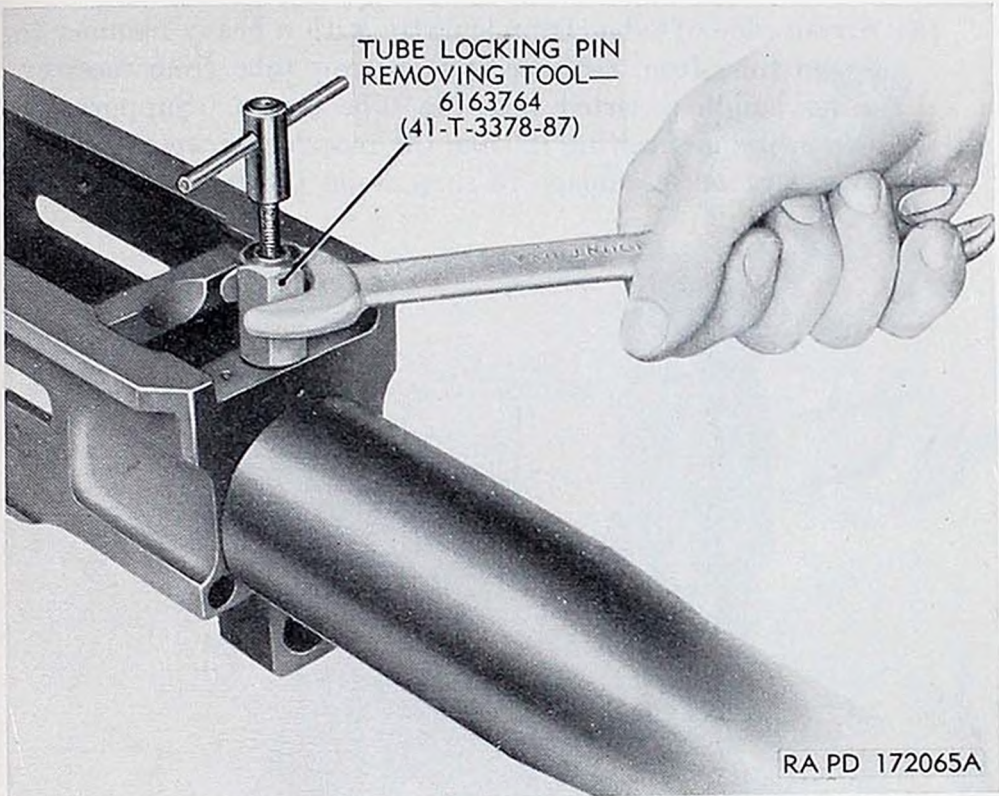

Figure 116. Removing tube locking pin.

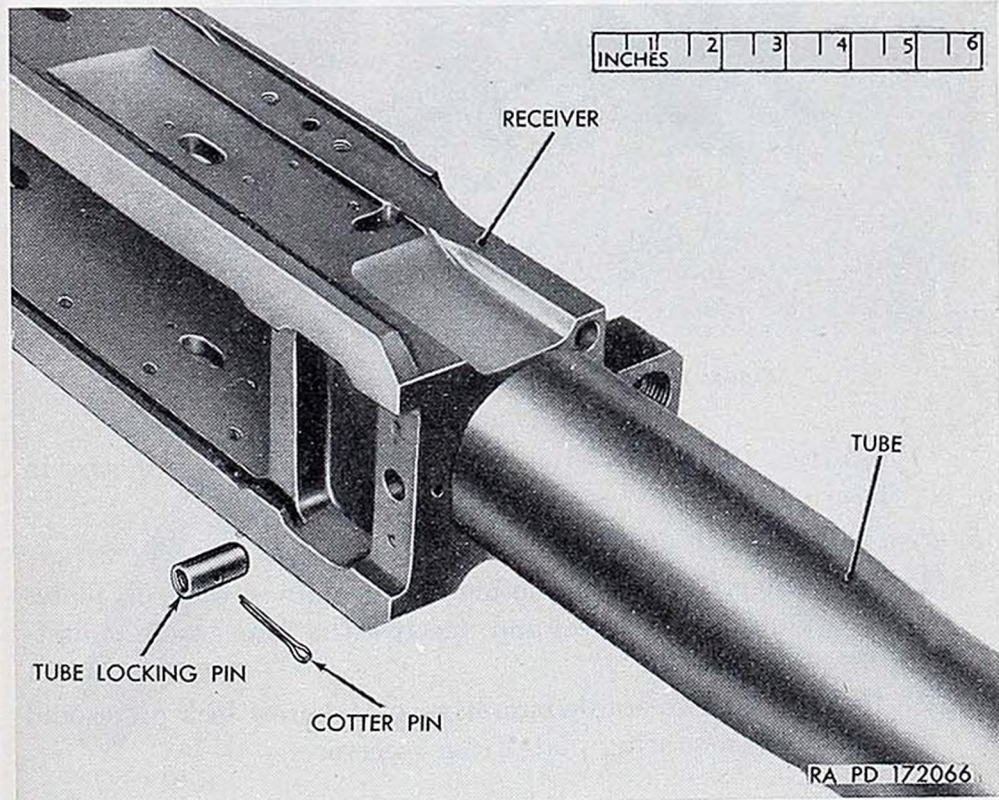

Figure 117. Tube locking pin removed.

RESTRICTED—Security Information

- (5) Strike edge of tube clamp smartly with a heavy hammer to loosen tube from receiver and unscrew tube from receiver, using handle inserted into the tube clamp. Support the tube while unscrewing it from the receiver, as weight of the tube may cause damage to threads on the tube and in the

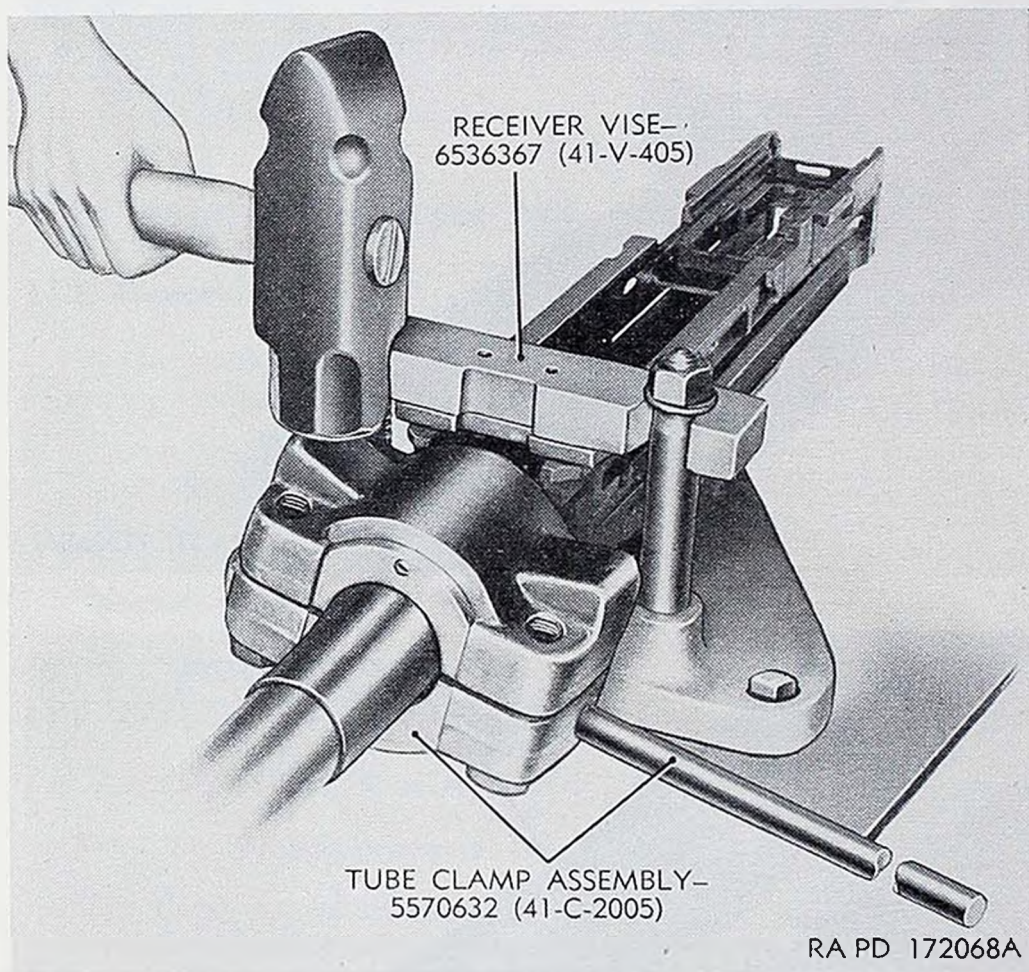

Figure 118. Loosening tube from receiver.

receiver. The separated tube and receiver are shown in figure 119.

b. Removal of Cradle Mounting Plate (fig. 120).

- (1) Straighten the two cradle mounting plate screw lock plates with a blunt cold chisel and unscrew the four cradle mounting plate screws.
- (2) Remove the two cradle mounting plate screw lock plates and lift cradle mounting plate from receiver.

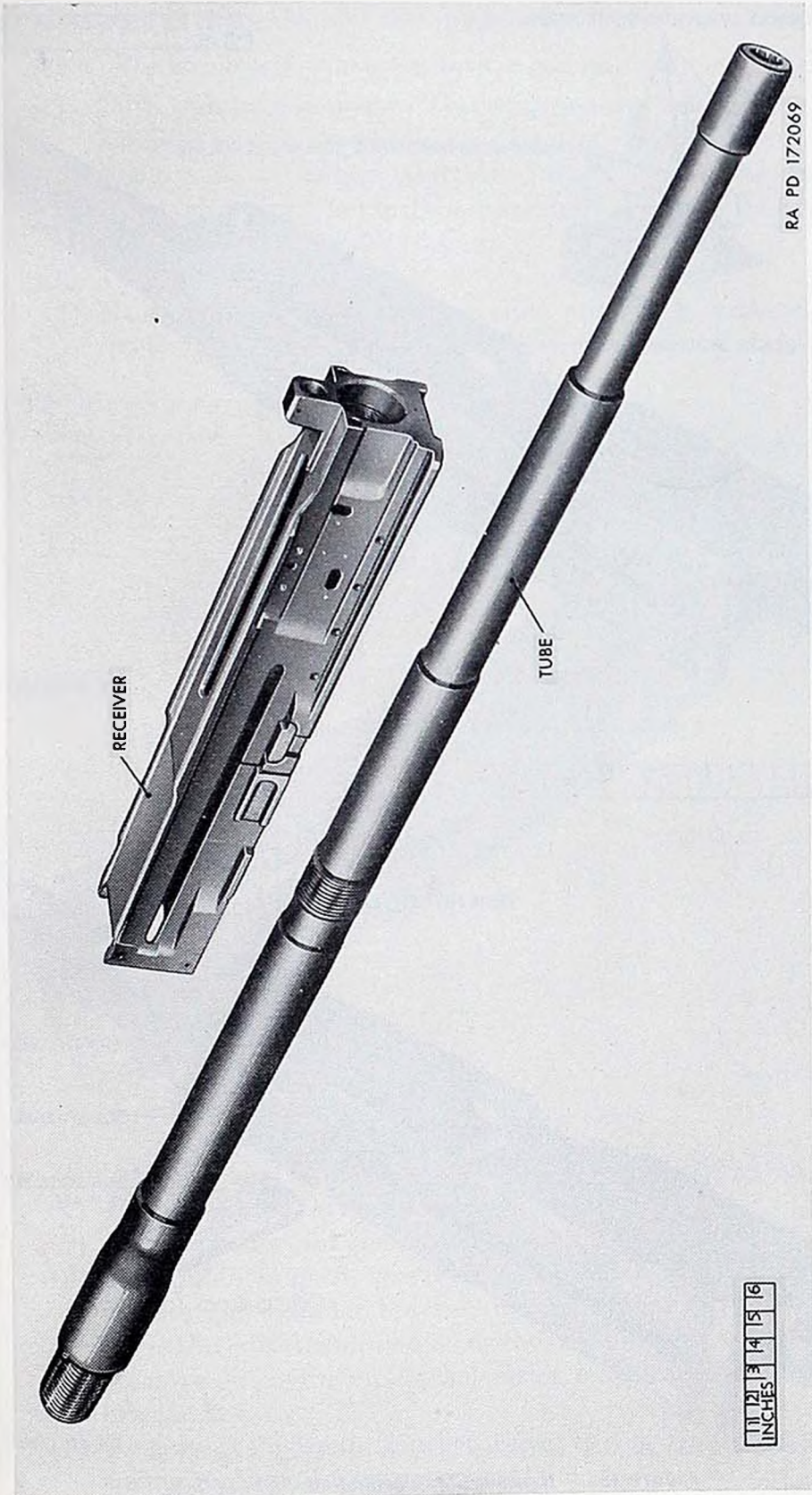

Figure 119. Tube and receiver.

RESTRICTED—Security Information

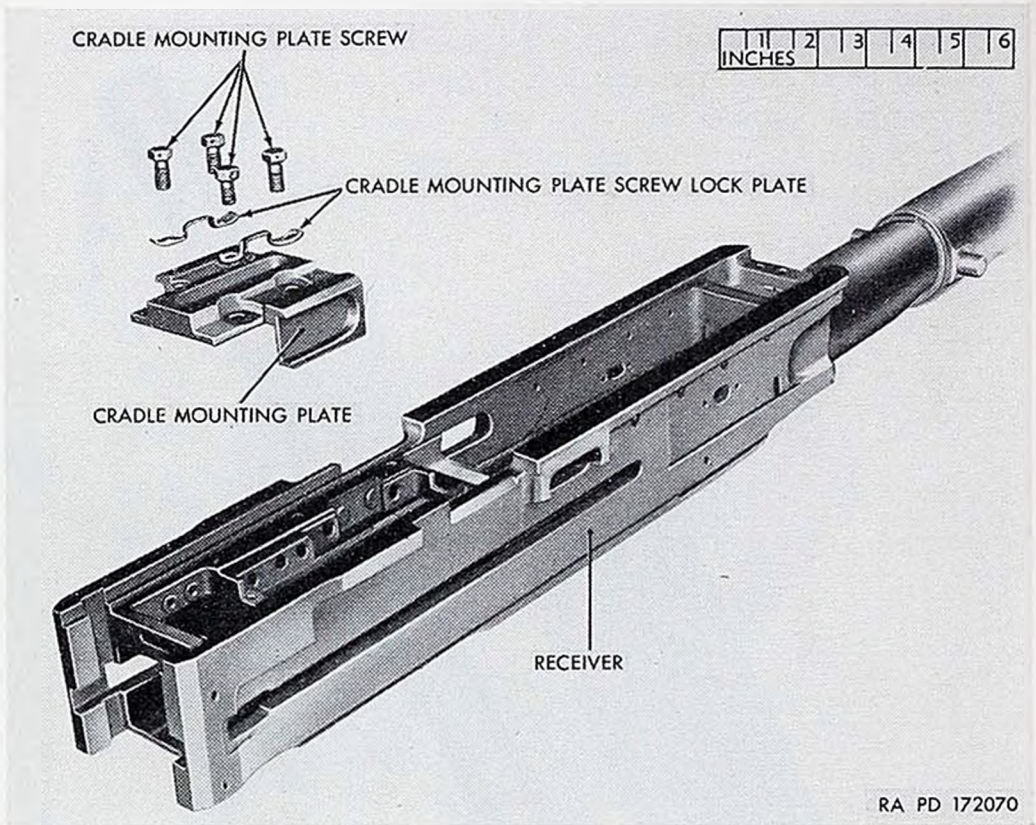

Figure 120. Removal of cradle mounting plate.

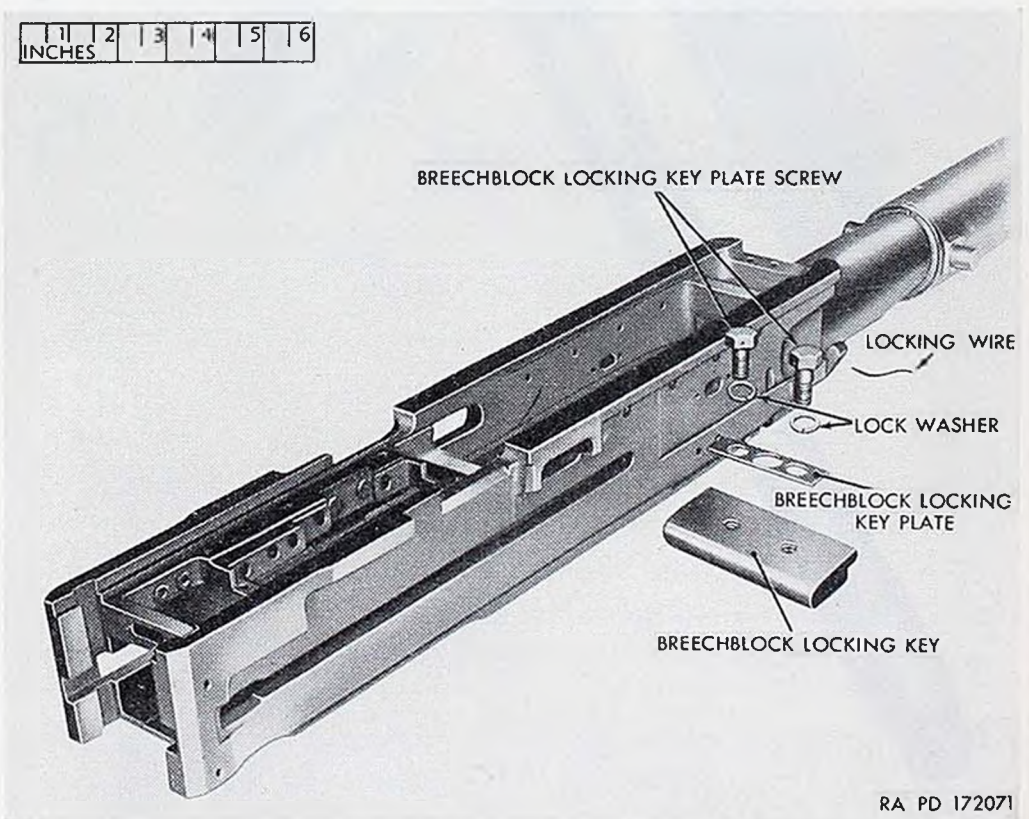

Figure 121. Removal of breechblock locking key.

RESTRICTED—Security Information

c. Removal of Breechblock Locking Key (fig. 121).

Note. The breechblock locking key is to be removed only for replacement.

- (1) Turn gun upside down. Cut and remove locking wire and remove the two breechblock locking key plate screws.
- (2) Remove lock washers and breechblock locking key plate. Drive out locking key with a brass drift or soft hammer.

d. Removal of Receiver Slides (fig. 122).

- (1) Turn gun upside down.
- (2) Remove cotter pins, receiver slide nuts, lock washers, and receiver slide bolts and then remove the receiver slides.

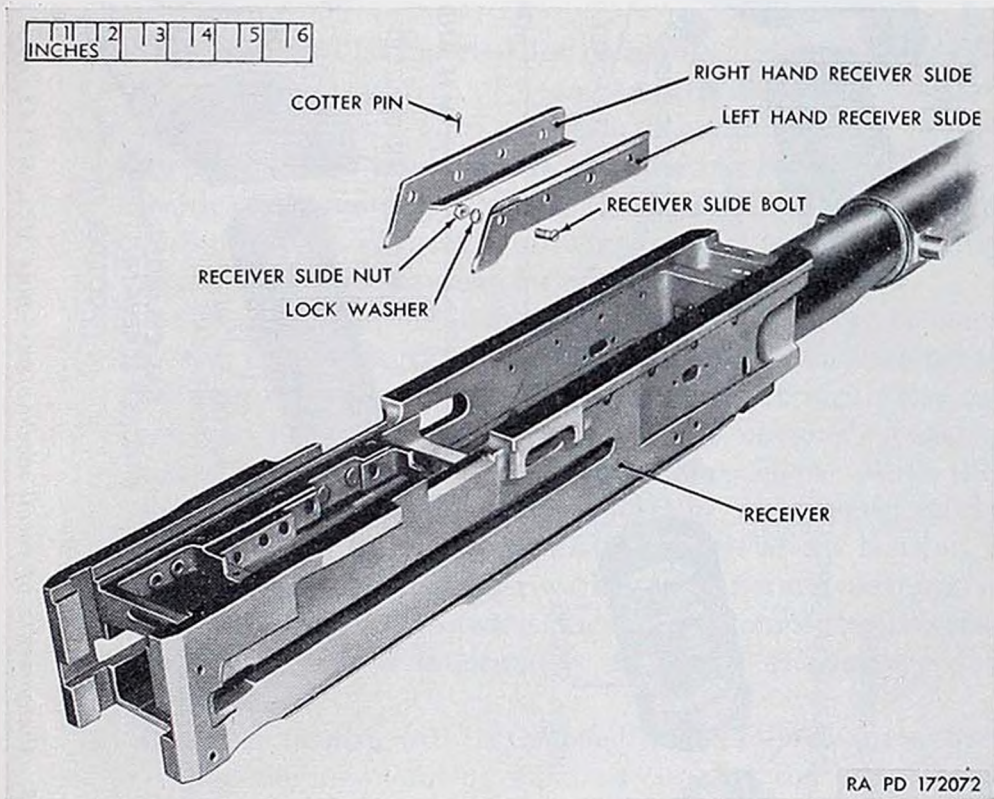

Figure 122. Removal of receiver slides.

e. Removal of Recoil Mechanism (Guns M24 and M24E2) (fig. 123).

- (1) Disassemble gas cylinder group (par. 76).
- (2) Remove cotter pin and loosen gas cylinder bracket screw nut.
- (3) Straighten tang in gas cylinder bracket nut washer and remove gas cylinder bracket nut. Removal of this nut relieves the initial compression on the recoil spring.
- (4) Remove gas cylinder bracket screw nut, bracket screw, and bracket key.
- (5) Remove gas cylinder bracket, recoil spring front seat, recoil spring, and recoil spring rear seat.

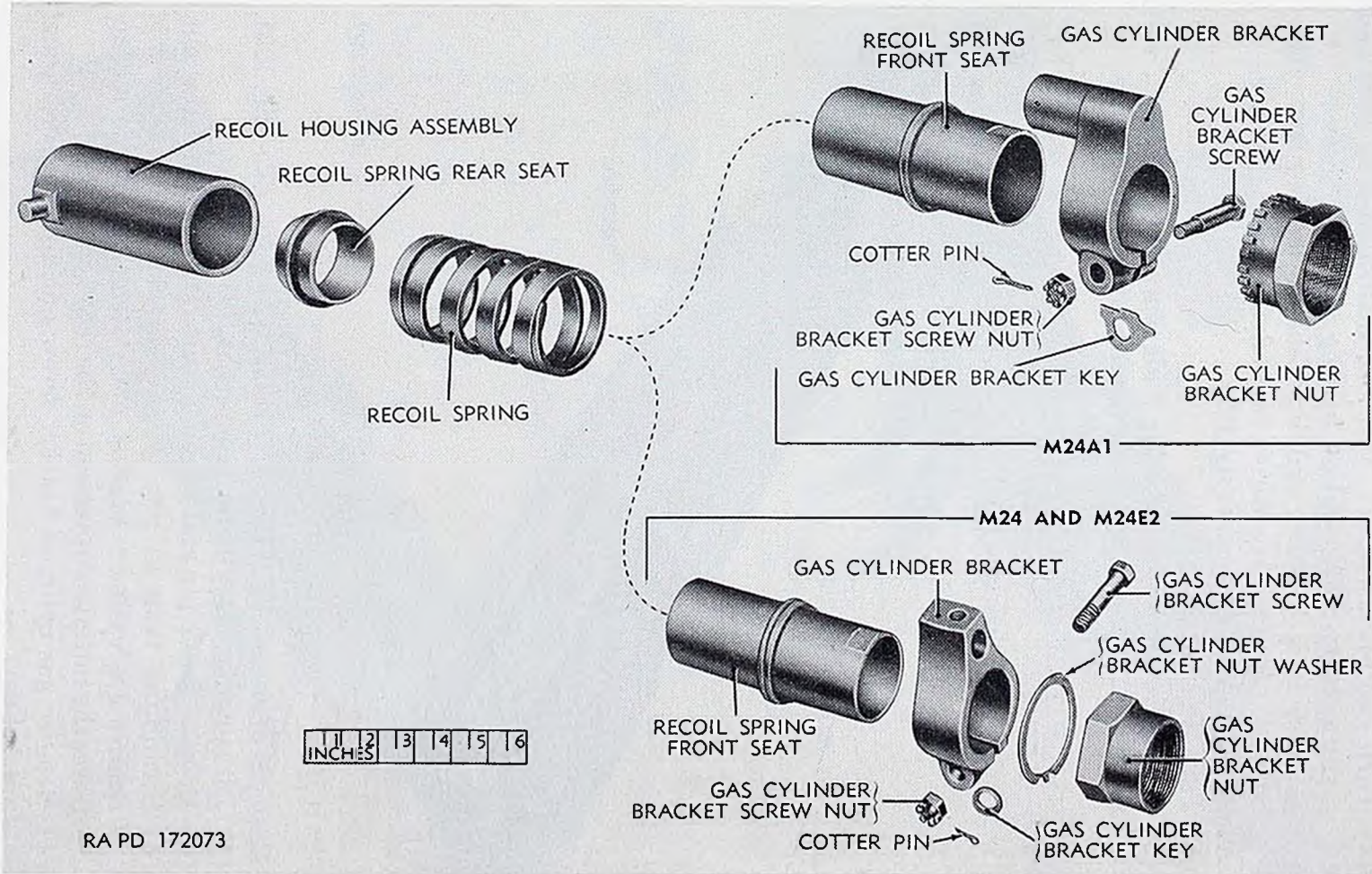

Figure 123. Components of recoil mechanism—guns M24, M24A1, and M24E2.

RESTRICTED—Security Information

- (6) Slide recoil housing assembly off tube. The recoil housing assembly must not be disassembled by field maintenance.
- f. *Removal of Recoil Mechanism (Gun M24A1) (fig. 123).*
 - (1) Disassemble gas cylinder group (par. 110).
 - (2) Remove gas cylinder bracket nut, gas cylinder bracket, recoil spring front seat, recoil spring, recoil spring rear seat, and recoil housing assembly. The recoil housing assembly must not be disassembled by field maintenance.

115. Maintenance

a. *Gun Tube.*

- (1) Gun tube will be inspected for corrosion and remaining life. Chamber will be free of chamber tarnish, carbon ring, or other roughness. This condition generally occurs just to the rear of the lands, where the rotating band of the projectile seats, and is very difficult to detect with the naked eye. This condition is brought about by normal use but is greatly aggravated by exposure to the elements.
- (2) A simple tool for use in checking bore condition can be made locally from a length of wire approximately 9 inches long by bending one end at right angles one-quarter inch from the end and flattening the short end with a hammer so that it resembles a miniature hoe with a sharp edge. With this simple tool, any significant roughness in the chamber will be amplified and the vibration distinctly felt as the hoe end is moved against the chamber wall. After normal cleaning, if any movement is detected, it is a sign of chamber tarnish that must be removed immediately to obtain satisfactory gun performance.
- (3) Chamber tarnish will be removed in the following manner:
 - (a) Grip the first joint of standard cleaning rod in a Jacob's chuck by means of an improvised adapter; special adapters will be issued at a later date.
 - (b) Move the tool back and forth with a rotary motion of the bore brush. This will remove all traces of chamber tarnish, carbon ring, or other roughness in approximately 5 to 15 minutes. This prepares the chamber for the final cleaning.
- (4) Use a piece of soft cloth, large enough to cover the circumference of the bore brush, dip in preservative lubricating oil (special), and wring out. The cloth is wrapped around the bore brush and the brush is rotated on a block of jeweler's rough (emery cake type No. 4, polishing and buffing com-

P12NAX

RESTRICTED—Security Information

**DEPARTMENT OF THE ARMY
TECHNICAL MANUAL**

**DEPARTMENT OF THE AIR
FORCE TECHNICAL ORDER**

TM 9-2006

TO 39A-5BA-4

**20-mm
AUTOMATIC GUNS
M24, M24A1
AND
M24E2**

*DEPARTMENTS OF THE ARMY AND THE AIR FORCE
APRIL 1953*

RESTRICTED

RESTRICTED—Security Information

pound) until the cloth is well coated with the rouge. The cloth covered brush is again placed in the chamber. The jeweler's rouge will polish the chamber wall to a mirror finish. All traces of the rouge will be removed from the chamber area.

- (5) The remaining life of the gun tube is checked with tube gage (modified) 7246264 as described in (a) through (i) below.

Note. Exercise care in use of gage. Rough handling may bend the shaft, score, bur, or scratch the gaging head. If damage is suspected, micrometer the diameter of the gaging head and discard if diameter is found to be outside the limits of 0.7965 and 0.7975 inch.

- (a) Remove the rear buffer, the driving spring group, and the breechblock from the gun.
- (b) Visually inspect the tube. If grease is present, clean the tube. A film of preservative lubricating oil (special) on the rifling can be tolerated by the gage.

Note. If there are partially stripped lands in the rifling area adjacent to the chamber, which protrude to impede the "bottoming" of the plug, the inspector will make note of the conditions and evaluate the gage readings accordingly.

- (c) Insert the gage through the rear of the receiver. Position the shaft so as to make readily visible the words "new," "half worn," and "reject" that are stamped 90° from the pin handle. Slide the hardened gaging head into the bore and position the measuring arm shoulder against the breech face to help aline the shaft with the bore.
- (d) When the measuring head on the tubular member of the gage has been firmly inserted into position and seated against the breech face, grasp the protruding knurled end of the shaft and move it gently forward. Also, rotate the shaft gently with finger pressure back and forth through an arc of approximately 20°. Continue these manipulations until the gaging head is firmly seated. An inspector will soon learn the "feel" of the gage, by which the encountering of minor obstacles is found to be different from the true "bottoming" of the gage. The inspector should also keep the protruding end of the gage near the center of the opening in the rear of the receiver during this "seating"
- (e) The gage reading is taken from the shaft, adjacent to the rear end of the tubular member, and will be obtained while the gage is properly "seated" ((a) through (d) above).
- (f) Three circumferential rings appear on the shaft, each with a descriptive word adjoining, namely: "new," "half worn," and "reject." These calibrations should provide a simple

RESTRICTED—Security Information

index for use in the field, but for more accurate gaging, a pocket scale may be placed against the end of the tubular member and exact position (between the marked calibration lines) can be measured. The "half worn" line is 6 inches behind the "new" line, while the "reject" line is 3 inches behind the "half worn" line.

Note. The tube must be at normal temperature during gaging. Use of the gage in a "hot" tube will give inaccurate readings and freezing of the head is likely.

- (g) Rejection points are 1-inch advance from the "new" line for tubes intended for combat use and 14-inches advance from the "new" line for tubes intended for training use.

Note. These rejection points apply only to unlined, unplated standard 20-mm gun tubes.

(h) Rejected tubes will be mutilated and transferred to salvage.

(i) In determining remaining life, the following exceptions will be noted: A tube that has been subjected to "cook-off" of a high explosive incendiary (HEI) projectile, with consequent gross enlargement of the tube diameter immediately forward of the chamber, will furnish an erroneous reading when this tool is used because the enlargement is localized in position and length; a gun subjected to "cook-off" of a high-explosive incendiary (HEI) projectile usually incurs considerable and characteristic damage. Breechblock components and receiver units will be broken. A slight bulge is usually found on the outside surface of the tube over the chamber.

b. Receiver.

- (1) Front end of receiver slides should be less than 0.002 inch from adjoining face of receiver; check with feeler gage. If necessary to disassemble and assemble slides or to correct assembly, drive slides forward against receiver to obtain this dimension. Care will be taken in assembly, however, as all slides are not interchangeable. Some slides are marked with large numbers "4," "8," and "12" and must be put together in pairs; both right and left slides must bear the same number. Marking is on side of the slide. Unmarked slides need not be kept in pairs.
- (2) Examine firing cable for defective insulation, broken wiring, and insulation pulled from under ferrule. Replace the cable, if any of these defects are found.
- (3) Inspect receiver at front and rear of charger slot and rear buffer grooves for cracks.
- (4) Magazine slide will move freely on machined grooves on top

RESTRICTED—Security Information

of receiver. Draw up ejector stud nut tight and back off three-quarters of a turn.

- (5) Breechblock locking key will not be burred or loose.
- (6) Inspect rear buffer for rough or peened surfaces on dovetails. Remove rough spots with crocus cloth or fine oilstone to secure a good push fit in the receiver. Buffer should not be loose enough to jar against the receiver.
Caution: Rear buffer will not be dipped in any cleaning fluids.
- (7) The buffer is lubricated with graphite at assembly and fluid will wash the graphite out and thus impair the functioning of the buffer. Buffer will not be disassembled by field maintenance. Exterior surfaces only will be cleaned with a dry or oily cloth.
- (8) Check rear buffer lock for free movement. Remove burs from lock or buffer to relieve binding. Lock must not fit loosely in receiver to prevent vertical motion of buffer during firing.
- (9) Replace all used driving spring guide retainers and driving spring cap lock plates that are cracked or broken or do not perform their intended function.
- (10) Buffer housing should be provided with drilled hole for driving spring guide retainer 7227771.
- (11) If available, black plastic breechblock contact 7238932 will be assembled to guns.
- (12) Note condition of threads on guide plunger; if mutilated or excessively worn, replace guide plunger. Check for looseness of head and for deformation; if loose or bent, replace guide plunger.
- (13) Check functioning of spring in guide plunger. Plunger will be extended fully and without binding.
- (14) Check functioning of magazine latch springs by hand. If springs are weak, replace them.
- (15) Magazine latch will slide freely in grooves of slide.
- (16) Replace ejector if stud or horns show signs of fracture. Inspect ejector for wear on slides and on the two prongs. Ejector must slide freely in groove of magazine slide, but should have very little side play.
- (17) Check ejector stud fiber washer for splits, seat, and thickness; replace if deformed.

116. Assembly and Installation

a. Assembly of Tube to Receiver.

- (1) Examine threads on new tube and coat them with a thin film of graphite grease (soft).
- (2) Install new tube and align hole in receiver with hole for tube locking pin.
- (3) Insure alinement of barrel plunger holes in tube and receiver (gun M24A1).
- (4) Ream a hole in tube to twenty-five sixty-fourths inch, using standard reamer; install tube locking pin and cotter pin.

b. Installation of Cradle Mounting Plate (fig. 120).

- (1) Install cradle mounting plate in recess on bottom of receiver. The opening for the roller guide slots should face the rear of the gun.
- (2) Position the two cradle mounting plate screw lock plates and screw in the four cradle mounting plate screws.
- (3) Bend the ends of the two cradle mounting plate screw lock plates against the heads of the four screws.

c. Installation of Breechblock Locking Key (fig. 121).

- (1) Drive breechblock locking key into its slot in the receiver with a soft hammer or brass drift. The indented side of the key should face the muzzle end of the gun.
- (2) Install the two breechblock locking key plates, lock washers, and screws and secure them with locking wire.

d. Installation of Receiver Slides (fig. 122).

- (1) Position slides in their respective slots in the receiver. Angled ends of receiver slides should point toward the rear of the gun.
- (2) Secure each receiver slide with four receiver slide bolts, receiver slide nuts, and lock washers and secure them with cotter pins.

e. Installation of Recoil Mechanism (Guns M24 and M24E2) (fig. 123).

- (1) Slide recoil housing assembly over front end of tube, with trunnions on housing facing rear of gun.
- (2) Install recoil spring rear seat, recoil spring, recoil spring front seat, and gas cylinder bracket, with recess in bracket for recoil washer tang facing toward muzzle end of gun.
- (3) Install gas cylinder bracket screw, key, and screw nut. Do not tighten screw until gas cylinder sleeve assembly has been checked for alinement. Assemble gas cylinder sleeve assembly

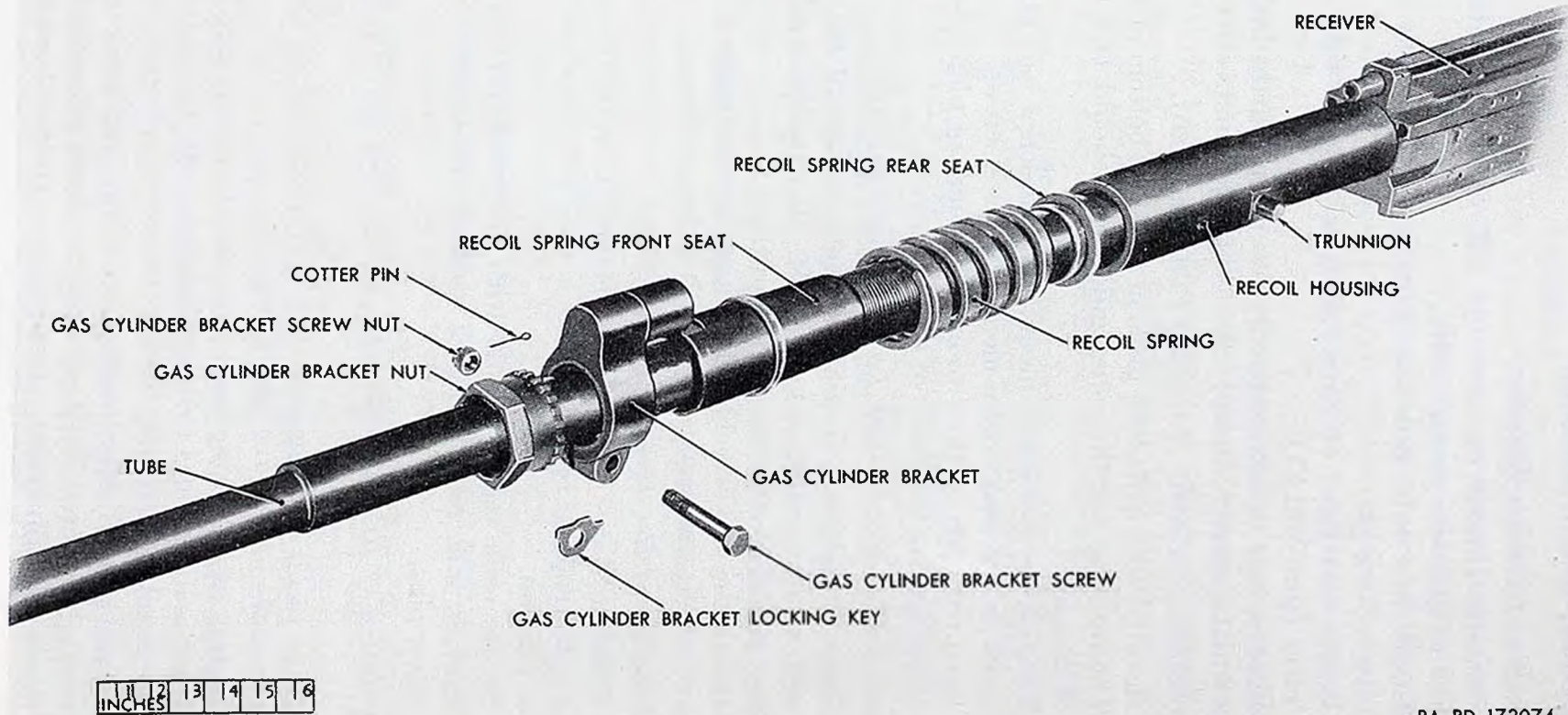

Figure 124. Assembly of recoil mechanism.

RESTRICTED—Security Information

to gas cylinder guide, without gas cylinder spring, and check for freedom of movement. If sleeve assembly does not move freely, move gas cylinder bracket to the right or to the left until it does, then tighten nut, and secure with cotter pin. The gas cylinder should have at least 0.01-inch clearance between the hex shoulder and the top of the tube to allow for heat expansion. This clearance may be checked with a 0.010-inch feeler gage. Tighten gas cylinder vent plug. Remove gas cylinder guide and install gas cylinder spring. Install gas cylinder guide and tighten with engineers wrench 5206718 (41-W-1209-40) (figs. 92 and 106).

- (4) Install gas cylinder bracket nut washer and bend tang into recess in gas cylinder bracket.
 - (5) Install gas cylinder bracket nut and tighten it.
- f. Assembly of Recoil Mechanism (Gun M24A1)* (figs. 123 and 124).
- (1) Slide recoil housing assembly over front end of the tube, with trunnions on housing facing receiver.
 - (2) Install recoil spring rear seat, recoil spring, recoil spring front seat, gas cylinder bracket, and gas cylinder bracket nut.
 - (3) Assemble gas cylinder group (par. 112).

117. Adjustment of Lock Clearance

If the average of the two lock clearance measurements (par. 15) is greater than 0.015 inch, adjustment is necessary. If the average of the two measurements is 0.016 to 0.020 inch, install a 0.008-inch oversize breechblock locking key. If the average of the two measurements is 0.021 inch or greater, install a 0.013-inch oversize breechblock locking key. Record the installation of oversize breechblock locking keys on AF Form 185.

Section IX. 20-MM CHARGER M6

118. Removal and Disassembly

a. Removal. For removal of charger M6 (figs. 125 and 126) from gun, refer to paragraph 18a(3).

b. Disassembly.

- (1) Cut and remove locking wire and unscrew jacket screws at rear of jacket (fig. 127). Pull off jacket (fig. 127).
- (2) Disengage connector fitting of charger cable from its seat in rear end plug (figs. 65 and 127). Disengage connector fitting of catch cable from its seat in the rear end plug (fig. 128).
- (3) Pull charger cable out.
- (4) Press slide assembly to the rear and remove it from plunger assembly (fig. 129).

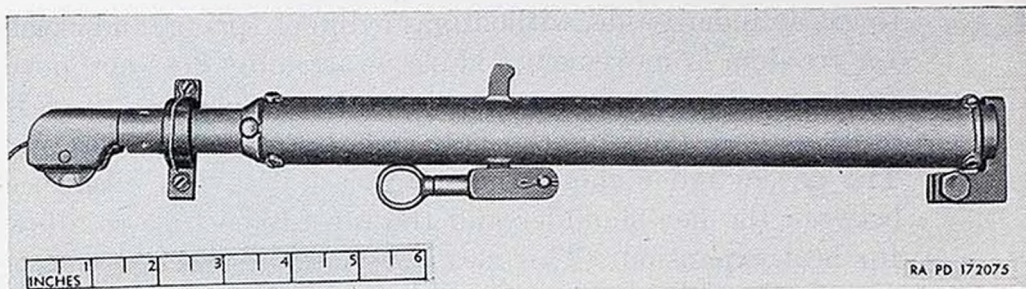

Figure 125. 20-mm manual charger M6—right-side view.

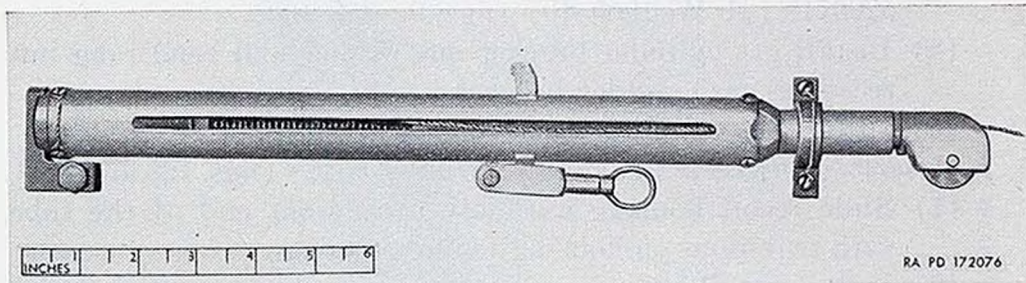

Figure 126. 20-mm manual charger M6—left-side view.

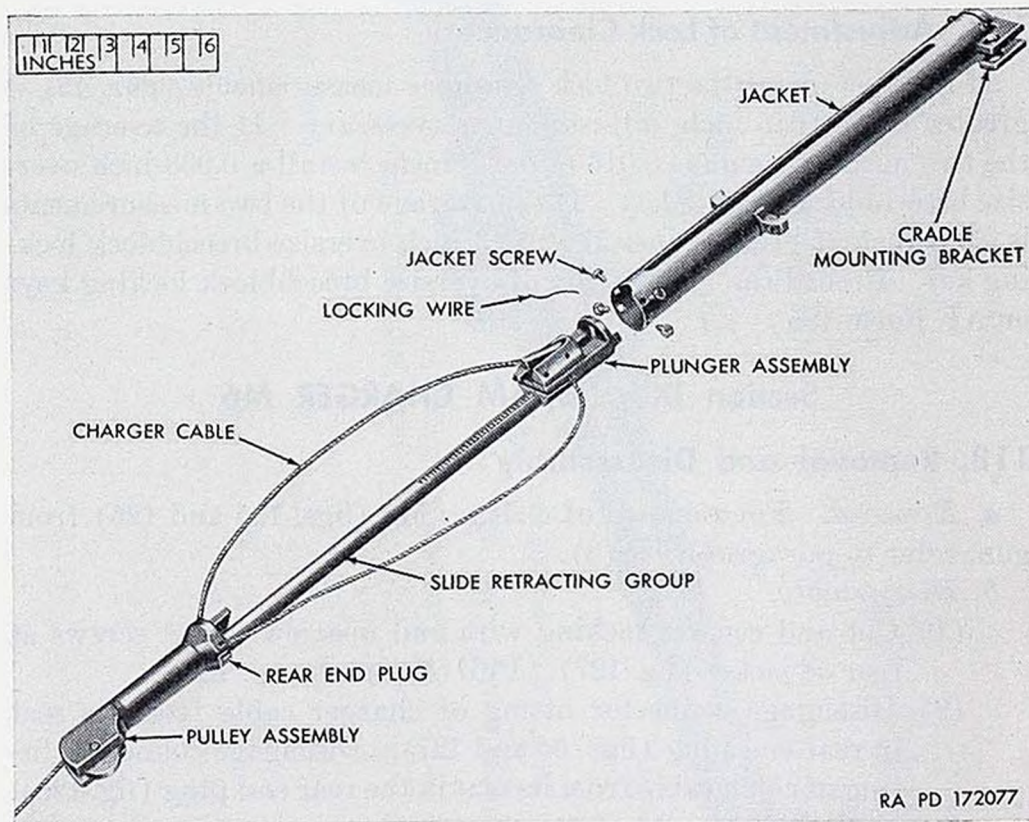

Figure 127. Component parts of 20-mm manual charger M6.

RESTRICTED—Security Information

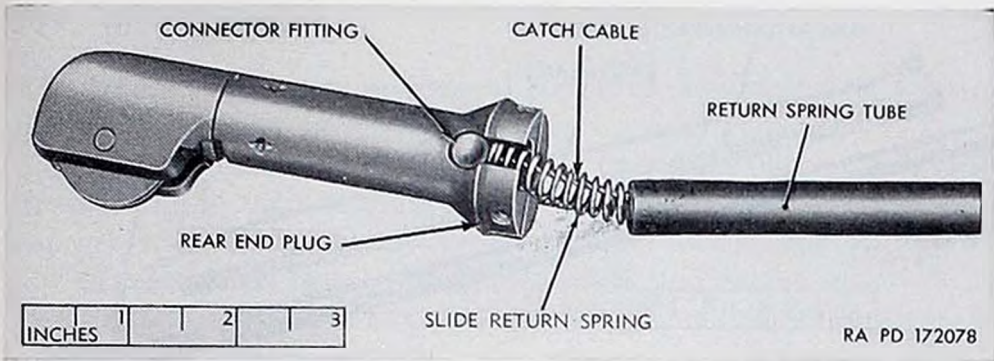

Figure 128. Disengaging catch cable—20-mm manual charger M6.

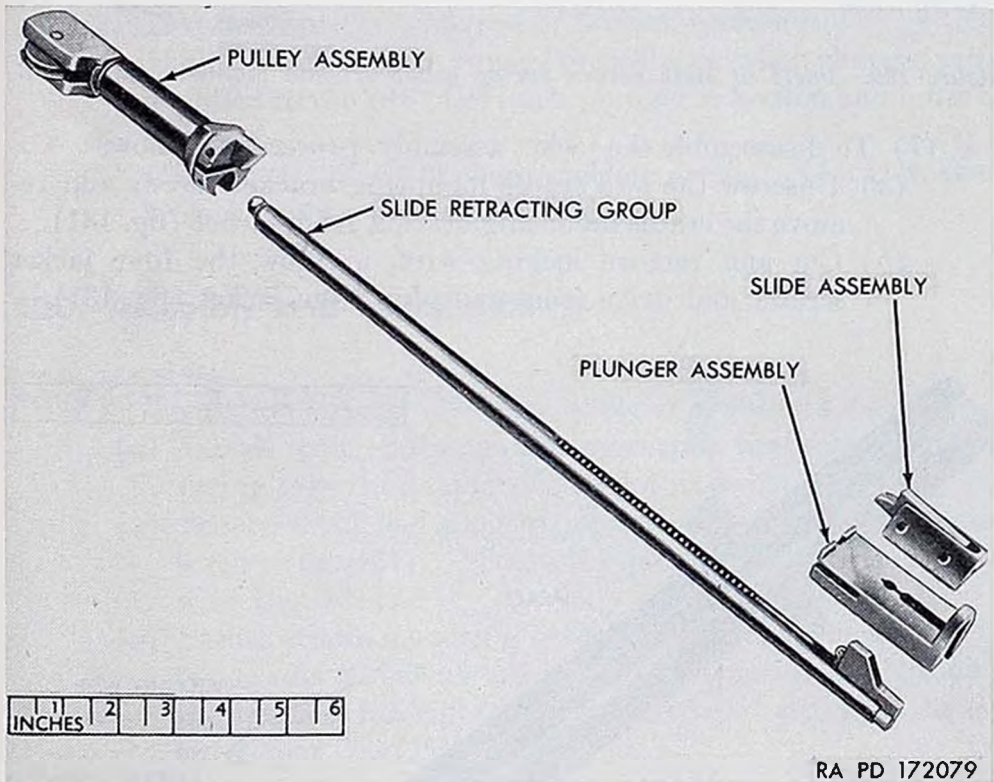

Figure 129. Slide, plunger, and pulley—20-mm manual charger M6

- (5) Press plunger assembly to the rear and disengage catch cable from its seat in plunger.
- (6) To disassemble the slide return spring group, proceed as follows:
 - (a) Drive out pulley pin, taking care not to lose catch pulley (fig. 130).
 - (b) Remove catch cable and return spring from return spring tube (fig. 130).
 - (c) Withdraw guide from return spring tube (fig. 130).

RESTRICTED—Security Information

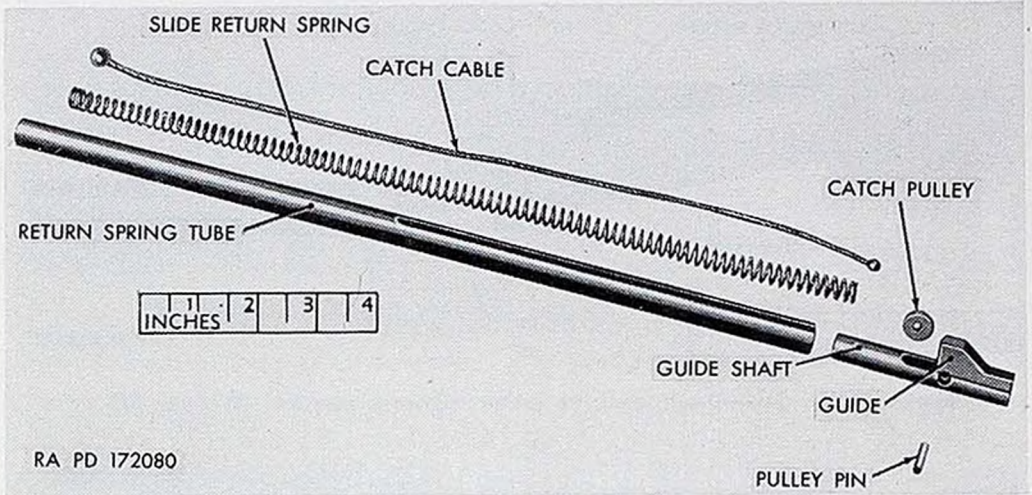

Figure 130. Parts of slide return spring group—20-mm manual charger M6.

- (7) To disassemble the jacket assembly, proceed as follows:
- Unscrew the two cradle mounting bracket screws and remove the cradle mounting bracket from jacket (fig. 131).
 - Cut and remove locking wire, unscrew the four jacket screws, and drive front end plug from jacket (fig. 131).

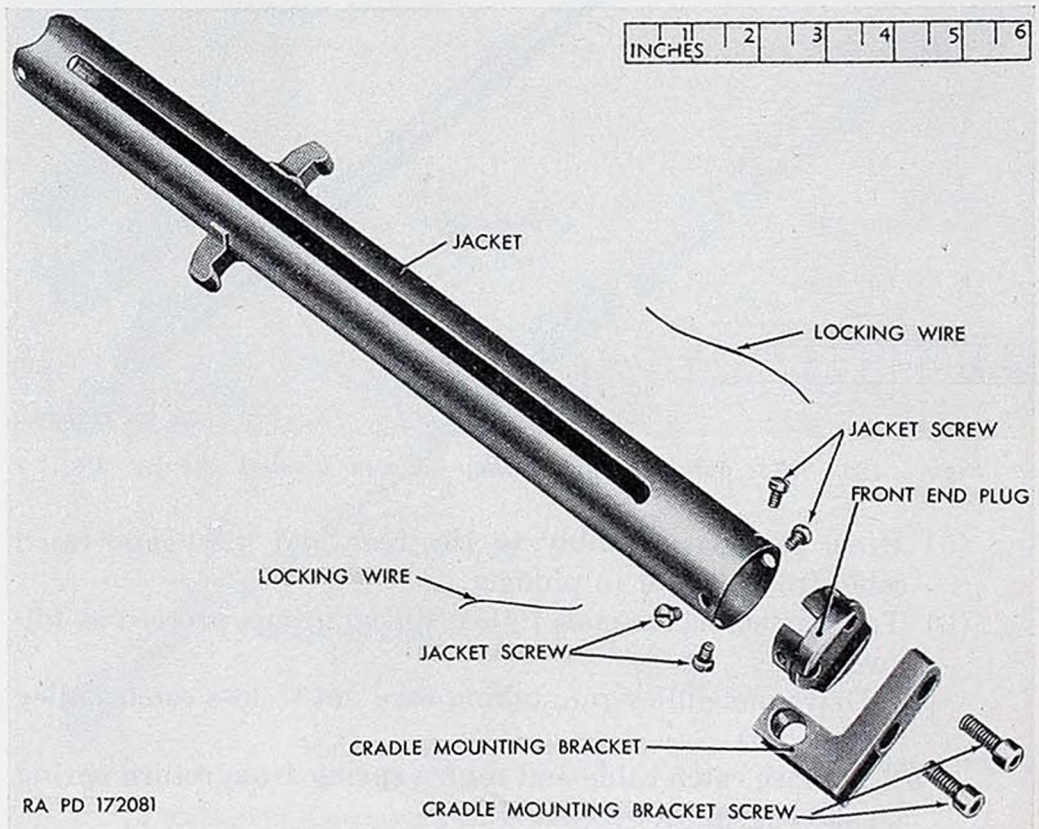

Figure 131. Parts of jacket assembly—20-mm manual charger M6.

RESTRICTED—Security Information

119. Maintenance

a. Examine charger for general condition and broken or missing parts.

b. Check functioning of charger. If operating parts are sluggish in returning to their original positions or if they fail to return when charger cable is released, disassemble charger and proceed as follows:

- (1) Examine jacket for dents; check movement of operating parts in jacket. If parts bind in jacket because of dents, replace jacket.
- (2) Examine the return spring tube for dents and straightness. If tube is bent or dented, replace it.
- (3) If return spring is warped or broken, replace it.
- (4) If slide latch fails to engage breechblock when charger cable is pulled to the rear, the latch plunger is broken and must be replaced.
- (5) Check functioning of charger clamp spring. If it is weak or broken, replace clamp assembly.

120. Assembly and Installation

a. Assembly.

(1) To assemble jacket assembly, proceed as follows:

- (*a*) Install front end plug, making certain that seat for return spring tube is on same side as slot in jacket (fig. 131).
- (*b*) Secure front end plug to jacket by means of four jacket screws (fig. 131). Secure the jacket screws with locking wire (fig. 131).
- (*c*) Secure cradle mounting bracket to jacket by means of the two cradle mounting bracket screws (fig. 131), positioning the bracket for right-hand or left-hand charging, as desired (par. 18*a*(1)).

(2) To assemble the slide return spring group, proceed as follows:

- (*a*) Insert catch cable into slide return spring (fig. 130).
- (*b*) Compress slide return spring and hold it compressed by gripping the cable with pliers, as shown in figure 132.
- (*c*) Pass small connector fitting of catch cable into shaft and out through the slot in the guide (fig. 132).
- (*d*) Position the catch pulley in the slot of the guide so that the small connector fitting and catch cable pass around catch pulley and drive in pulley pin, as shown in figure 132. Release grip on catch cable.

RESTRICTED—Security Information

- (e) Slide return spring tube on shaft of guide so that slots aline, as shown in figure 129.
- (f) Compress the slide return spring nearest the large connector fitting with pliers and position large connector fitting in its seat in the rear end plug (fig. 128). Release grip, allowing catch cable to seat in slot in rear and plug (fig. 128).
- (g) Tap return spring tube into slot in rear end plug (fig. 128). Aline guide and pulley assembly.

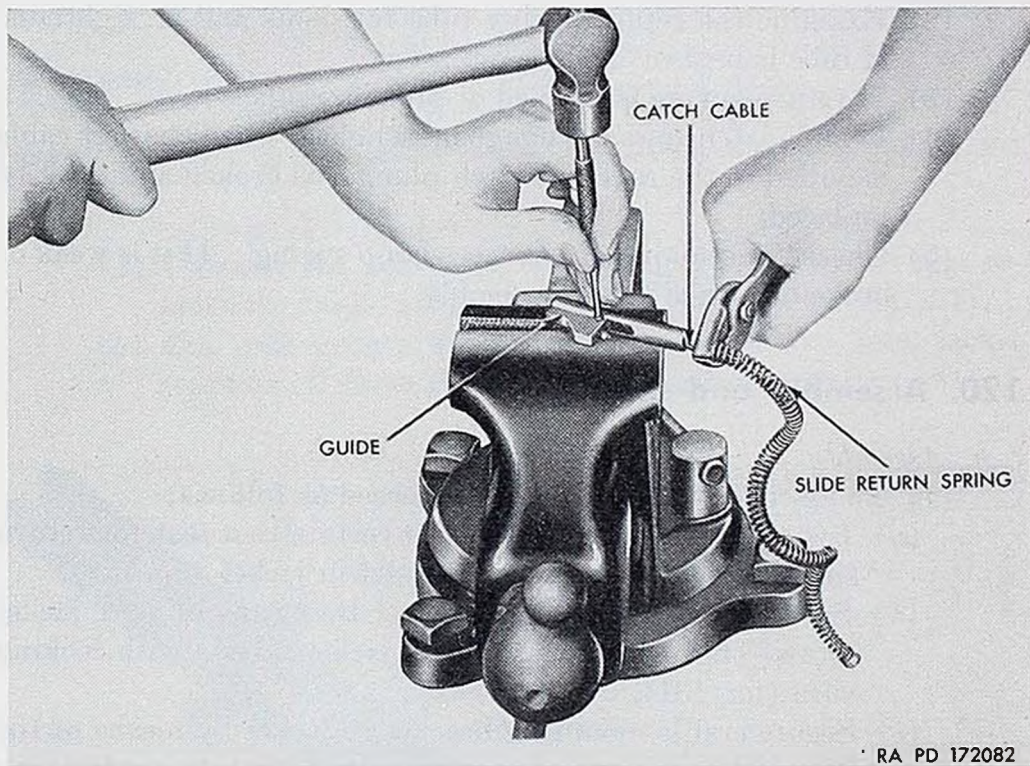

Figure 132. Assembling the slide return spring group—20-mm manual charger M6.

- (3) Assemble plunger assembly on return spring tube so that guide fits into slot in plunger assembly (fig. 129).
- (4) Press slide assembly against guide and position slide assembly on plunger assembly so that slide latch points towards pulley assembly (fig. 129).
- (5) Position connector fitting of charger cable in seat of rear end plug and pass free end of charger cable around latch pulley in plunger assembly, through plug and around sheave of pulley assembly (fig. 127).
- (6) Push assembly unit into jacket, being careful to aline latch of slide assembly with slot in jacket (fig. 127). Install the

RESTRICTED—Security Information

four jacket screws and secure them with locking wire (fig. 127).

b. Installation. For installation of the 20-mm manual charger M6 on the gun, refer to paragraph 18a(2).

Section X. 20-MM PNEUMATIC CHARGER M4

121. Removal and Disassembly

a. Removal. For removal of the 20-mm pneumatic charger M4 from gun, refer to paragraph 18b(3).

b. Disassembly.

- (1) Remove driving lug (par. 18b(1)).
- (2) Back off lock ring and unscrew cylinder end (fig. 133). The piston assembly will be pushed out by the piston return spring (fig. 134).

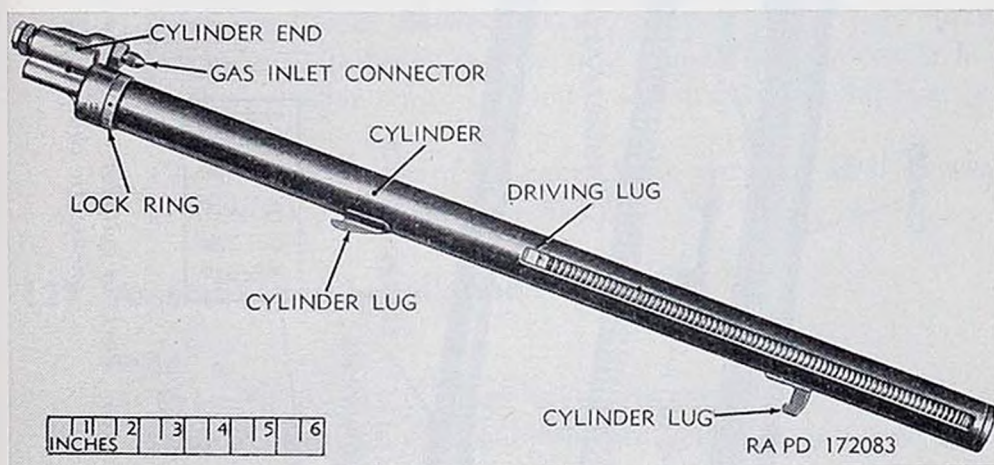

Figure 133. Disassembly of 20-mm pneumatic charger M4.

- (3) Remove the three steel spring washers and all the brass washers from inside piston (fig. 134). Each charger has three steel spring washers; the number of brass washers varies and is determined at assembly during manufacture.
- (4) Unscrew gas inlet connector from the cylinder end (fig. 134).
- (5) Disengage tang of piston packing ring from the piston nut, unscrew the piston nut, and remove piston nut gasket and piston nut gasket retainer (fig. 134).
- (6) Remove piston packing ring and piston packing. Discard piston packing ring.

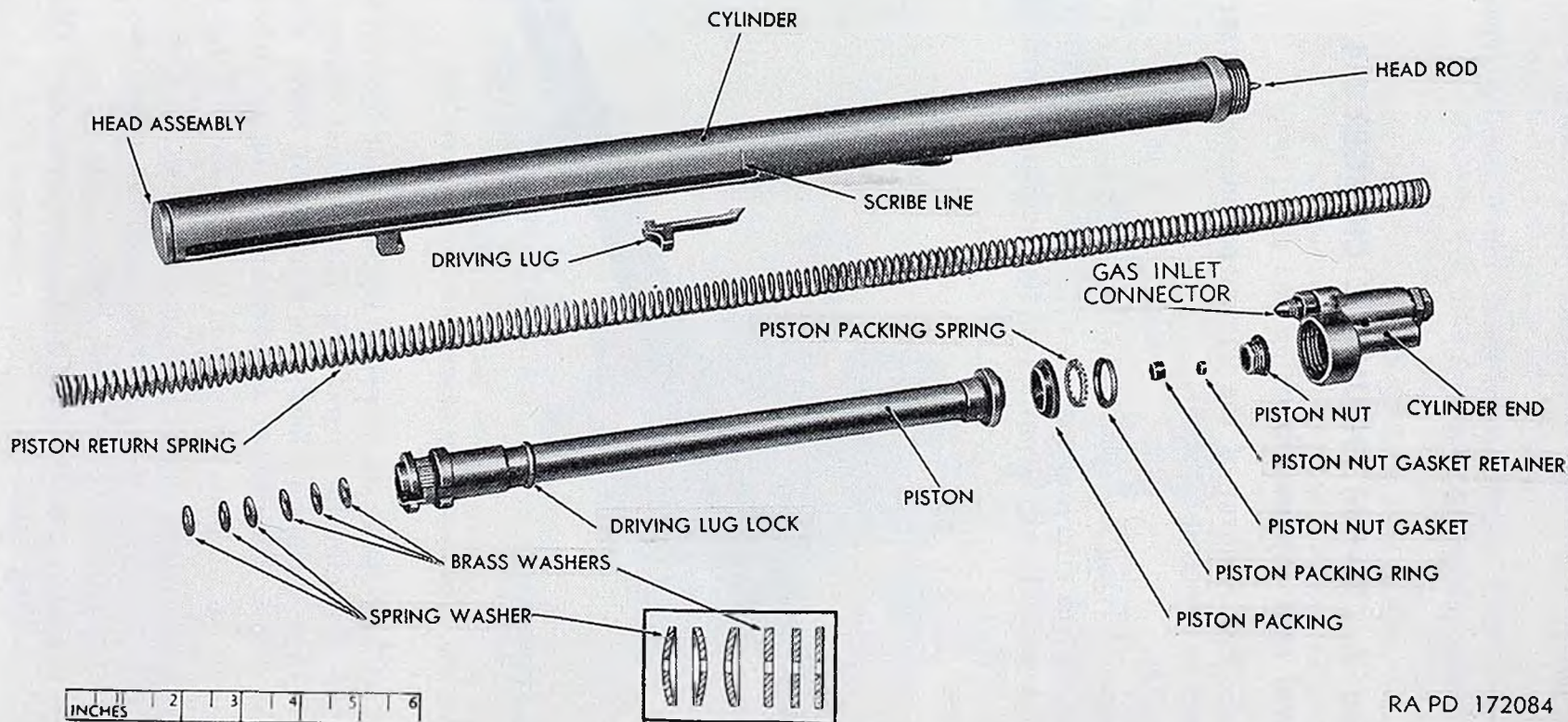

Figure 134. Parts of cylinder and piston assemblies—20-mm pneumatic charger M4

RESTRICTED—Security Information

122. Maintenance

a. Examine charger for general condition and missing and broken parts.

b. Check functioning of charger. If piston is sluggish in returning to its original position or fails to return, disassemble charger and proceed as follows:

- (1) Examine cylinder for dents; check movement of piston in cylinder. If piston binds because of dents, replace charger.
- (2) If rod head binds in piston, replace charger.
- (3) If piston return spring is warped, set, or broken, replace it. Remove any burs with an oilstone.
- (4) Examine cylinder gasket, piston packing and ring, and piston gasket and retainer for condition; replace any damaged parts.

Note. The piston packing ring should be replaced regardless of its condition.

- (5) Inspect cylinder end for cracks and stripped threads. If these conditions exist, replace cylinder end. Test spring action of ball checks by inserting a small wire in center hole in the cylinder end. If spring action is weak, replace cylinder end.
- (6) Check functioning of charger clamp spring. If it is weak or broken, replace clamp assembly.

123. Assembly and Installation

a. Assembly.

- (1) Prior to assembly, clean all parts with a clean cloth and then wipe them with a cloth dampened with preservative lubricating oil (special).
- (2) Insert piston packing (round end leading) into head of piston (fig. 134).
- (3) Insert the piston packing spring (fig. 134).
- (4) Insert new piston packing ring into piston packing spring (fig. 134).
- (5) Insert piston nut gasket retainer and piston nut gasket into piston nut, screw nut into piston head, and engage tang of piston packing ring with piston nut (fig. 134).
- (6) Hold the cylinder vertical, with head rod pointing up, slip the steel washers around head rod (washers must be in reversed positions to give spring effect), and follow with the brass washers (fig. 134). Slip the piston (open end lead-

RESTRICTED—Security Information

- ing) around the head rod (fig. 134) and turn the unit upside down and remove cylinder.
- (7) Insert the piston return spring into the piston (fig. 134), while holding piston in vertical position, open end up.
 - (8) Hold cylinder in vertical position, directly above open end of piston, with head rod pointing down into piston. Press cylinder down against spring pressure until rod passes through the washers and the opening in the piston head and screw cylinder end into cylinder (fig. 134).
 - (9) Install driving lug (par. 18b(1)).
 - (10) Adjust stroke position of operating face of driving lug by screwing and unscrewing end until lug face is alined with scribed line near slot on cylinder and then back off end until it is at right angles to slot in cylinder and gas inlet connector and cylinder lugs are on opposite sides of the cylinder (fig. 133).
 - (11) Screw lock ring tightly against the cylinder end (fig. 133).

b. Installation. For installation of the 20-mm pneumatic charger M4 on gun, refer to paragraph 18b(2).

Section XI. 20-MM FEED MECHANISMS AN-M2, M2E4, AND M2E5

124. Disassembly of Feed Mechanism AN-M2

Note. The feed mechanism can be disassembled more easily and with less likelihood of distorting the feed mouth and link deflector while it is on the gun and with the operating lever disengaged from the gun.

Note. The operations illustrated in this paragraph, whether with a right-hand or left-hand feed mechanism, are applicable to both types.

a. Remove locking wire and the three screws and lock washers on rear side of feed mechanism, as shown in figure 135. Remove driving mechanism release nut retaining plate, driving mechanism release nut, and rear end bearing (fig. 136).

b. Remove locking wire and the three screws on front side of feed mechanism, as shown in figure 137. Remove clutch retaining nut bearing retaining plate and front end bearing (fig. 138).

c. Remove cotter pin and pivot pin and withdraw operating lever (fig. 139).

d. Push link operating crank retainer (fig. 140) upward and remove it.

e. Unlock feed chute adapter from feed frame and remove feed chute adapter (fig. 141).

RESTRICTED—Security Information

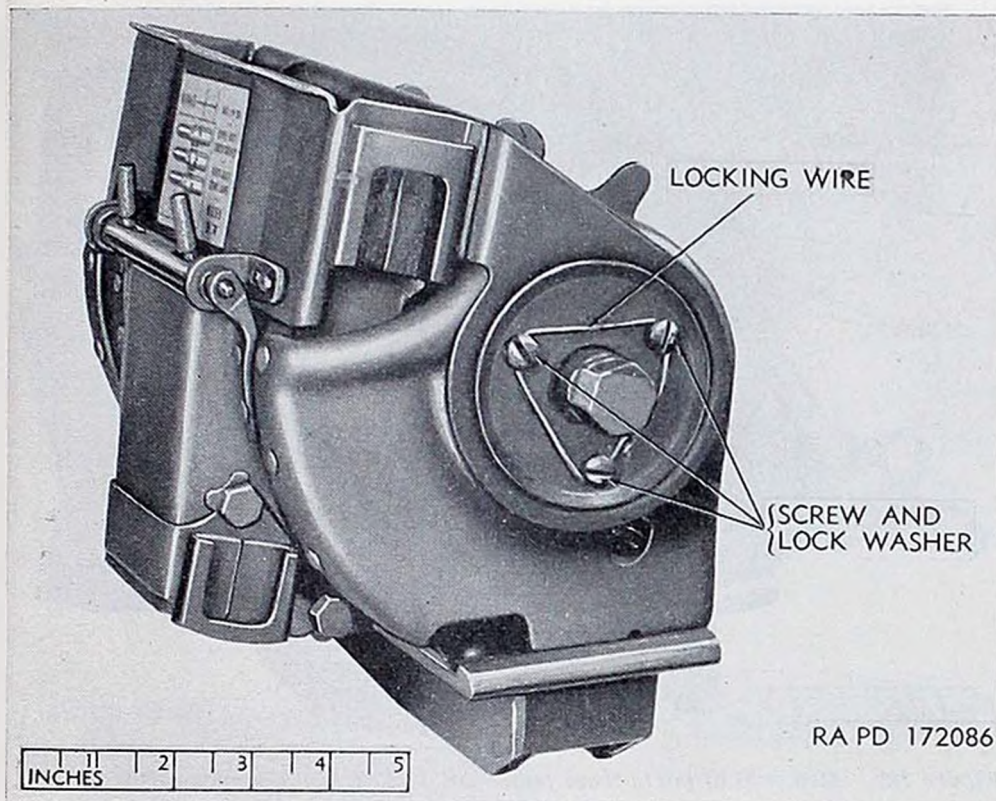

Figure 135. Removal of parts from rear end of 20-mm feed mechanism AN-M2.

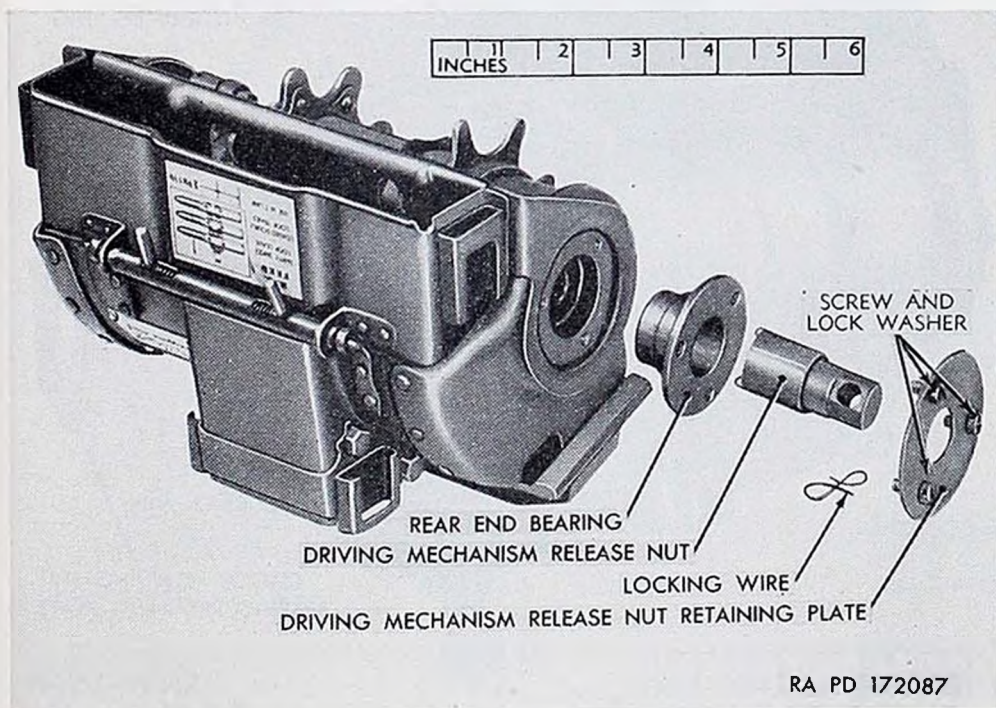

Figure 136. Parts removed from rear end of mechanism AN-M2.

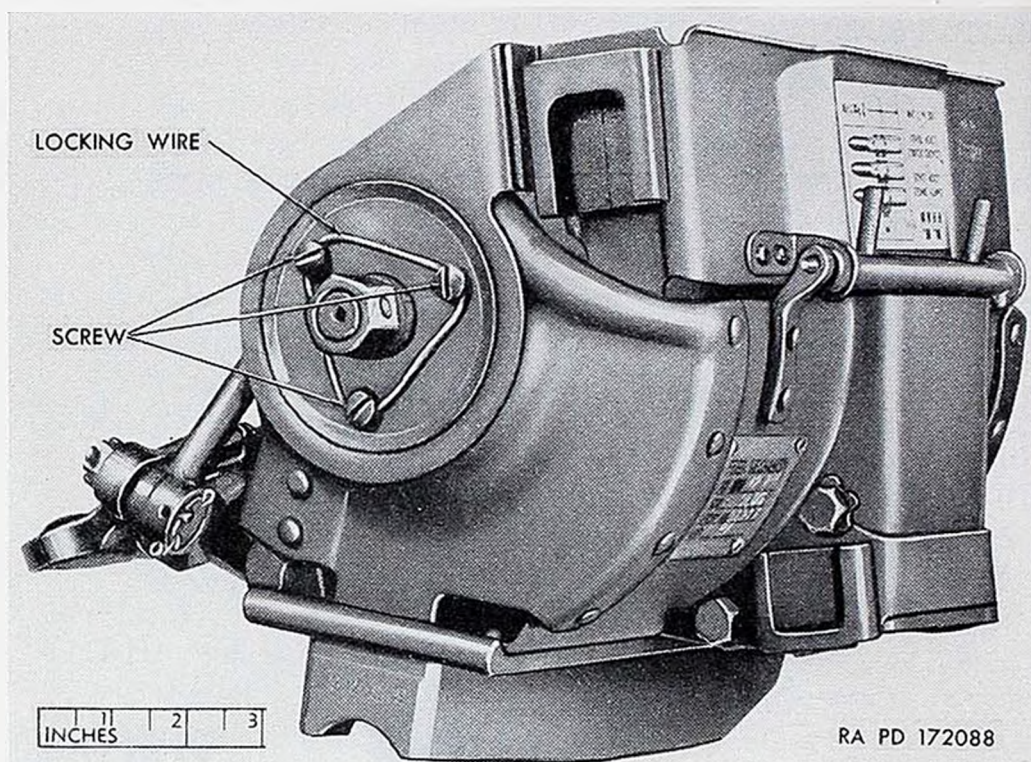

Figure 137. Removal of parts from front end of 20-mm feed mechanism AN-M2.

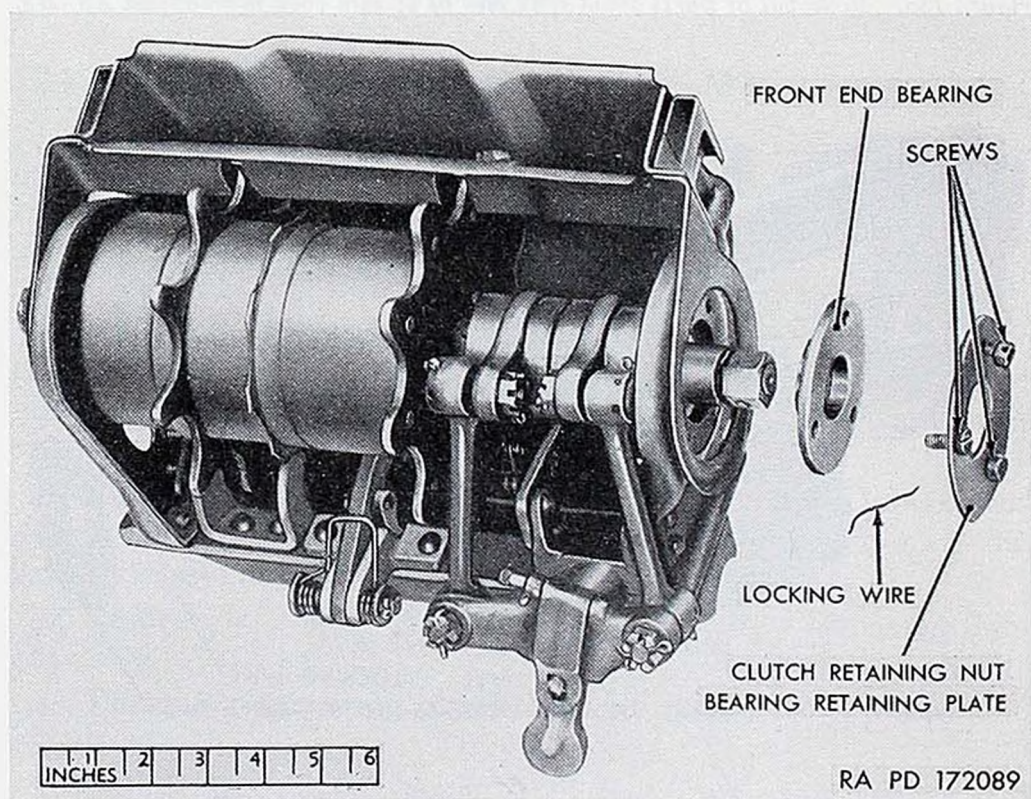

Figure 138. Parts removed from front end of mechanism AN-M2.

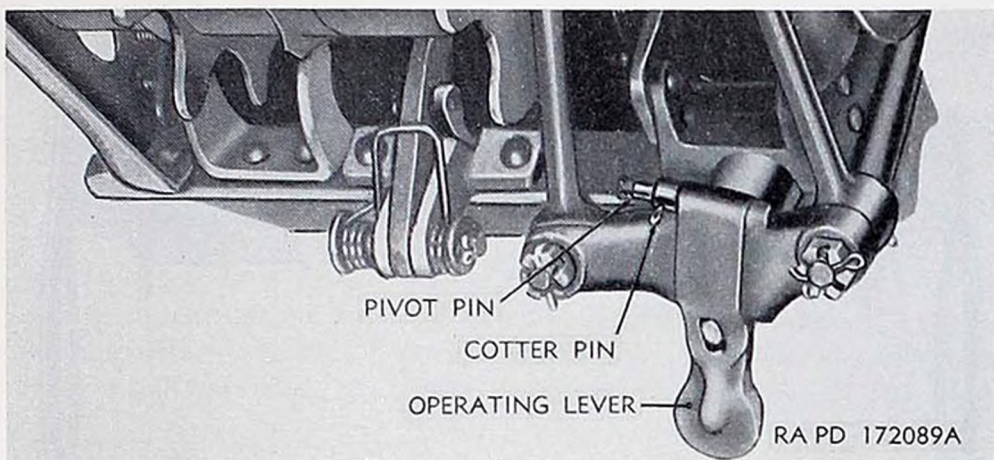

Figure 139. Removing operating lever from feed mechanism AN-M2.

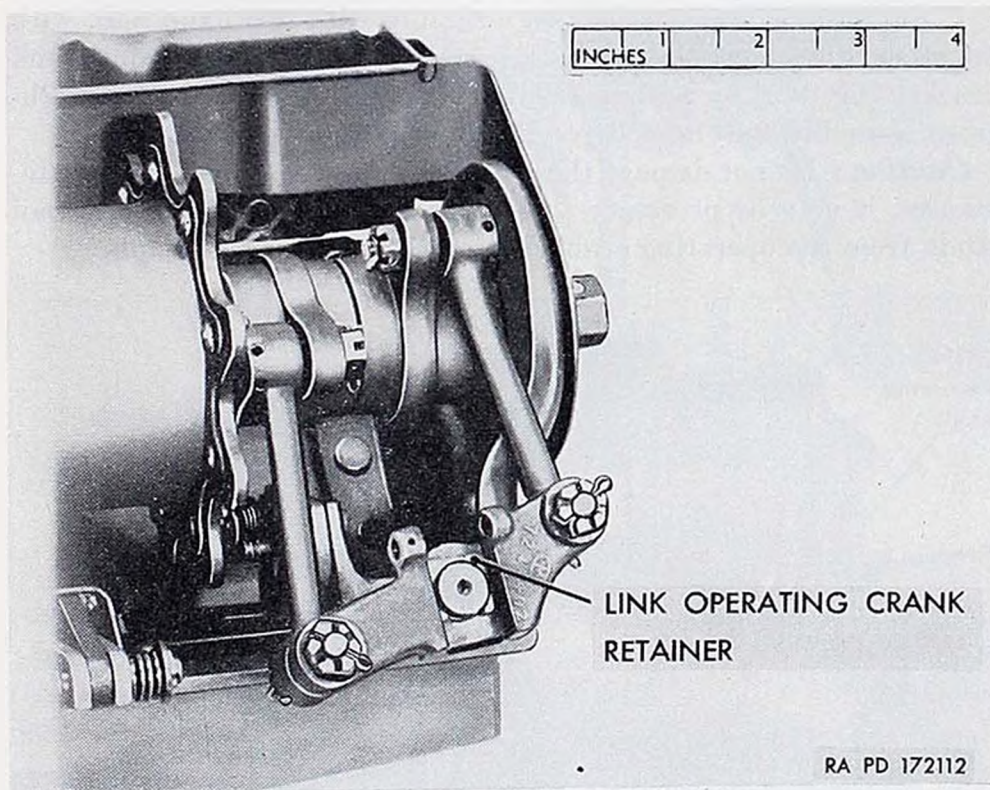

Figure 140. Removing link operating crank retainer from feed mechanism AN-M2.

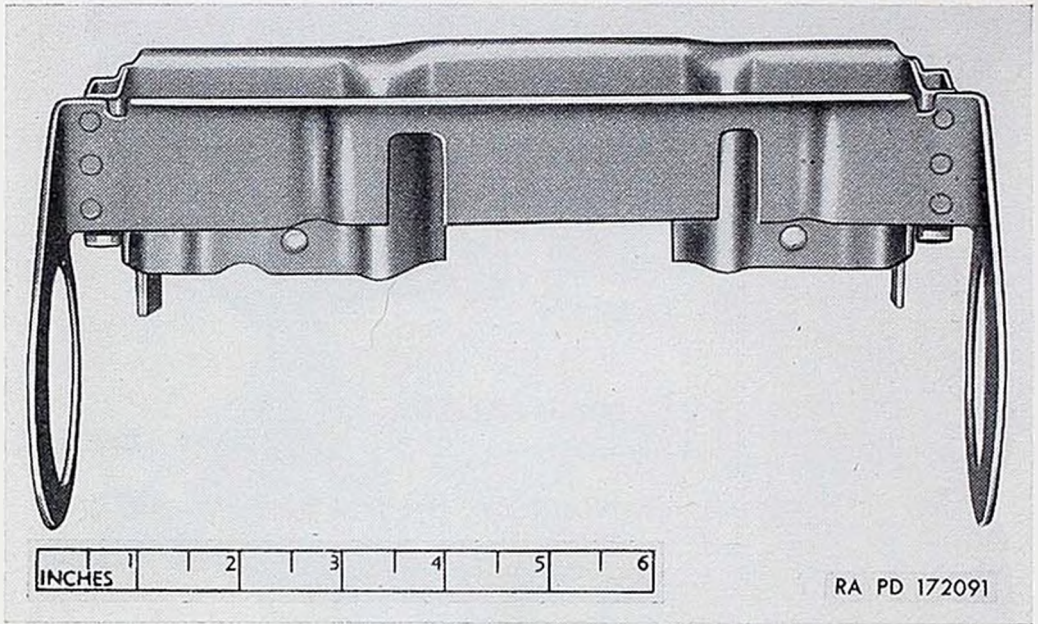

Figure 141. Feed chute adapter.

f. Support driving mechanism assembly with one hand and, with the other, disconnect link operating crank from link operating crank bracket (fig. 142) by pulling crank outward. Remove driving mechanism assembly and clutch drive group from feed frame.

Caution: Do not damage these parts by forcing them. In some instances, it may be necessary to remove one or two of the link ball studs from the operating crank in order to remove the crank.

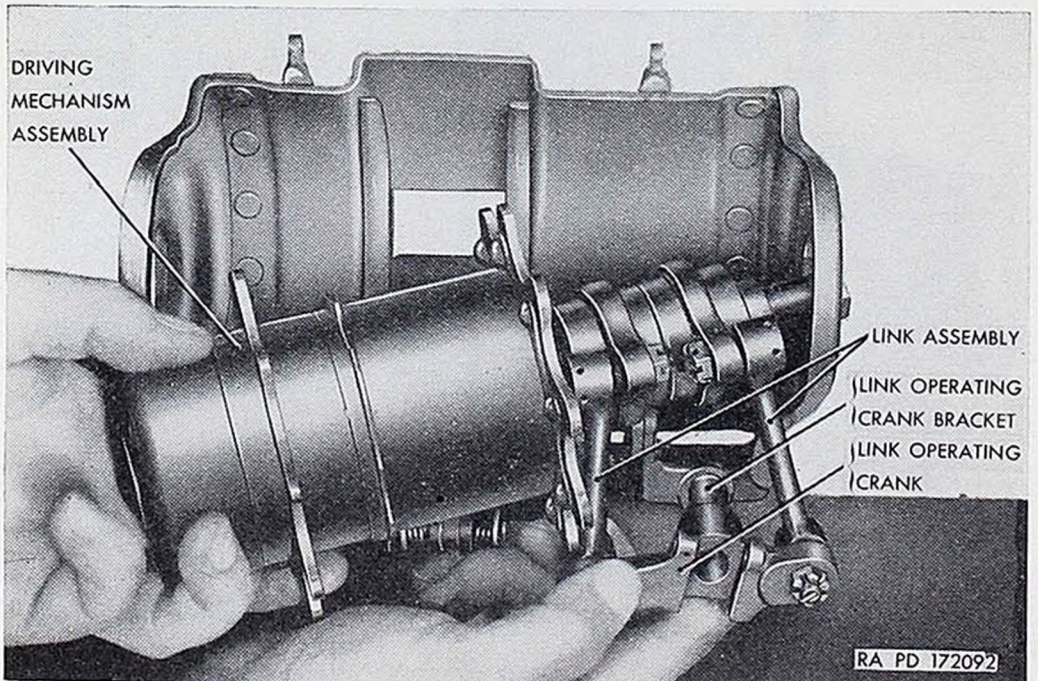

Figure 142. Removal of driving mechanism assembly and clutch drive group.

RESTRICTED—Security Information

g. Drive out rivet from winding nut (fig. 143). Drive out pins from clutch front and rear hubs (fig. 143).

Note. In driving out the pins, support the group on an improvised driving mechanism holding fixture (fig. 107) to avoid damage to the driving mechanism.

h. Remove winding nut (fig. 143). Slide off clutch drives (fig. 144), with links and operating crank as a unit.

i. Insert a drift punch through holes of clutch hub, twist clutch spring in a direction tending to wind it, and remove clutch spring while turning it in clutch pocket (fig. 145). Separate clutch spring from clutch hub (fig. 146). Withdraw clutch spring spacer (fig. 146).

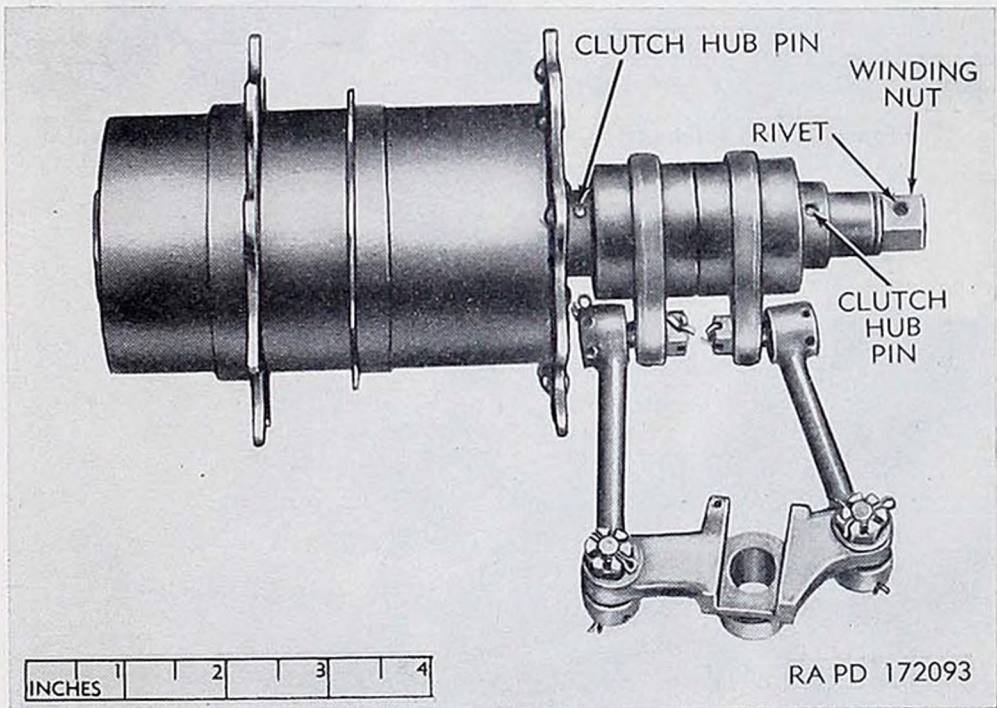

Figure 143. Clutch drive and driving mechanism group.

j. Remove cotter pins and castellated nuts from the four link studs (fig. 146). Remove cotter pins from the four stud plugs and unscrew the four stud plugs (fig. 146). Drive out studs with a soft hammer, being careful not to damage threads.

k. Remove cotter pins and washers, unhook cam springs, and slide off cartridge holding front and rear cams (fig. 147).

l. Remove cotter pins and washers from cartridge control pawl pin, hold control pawl spring in place, and pull out cartridge control pawl pin (fig. 147). Remove cotter pins and slide out cartridge holding dog pin (fig. 147).

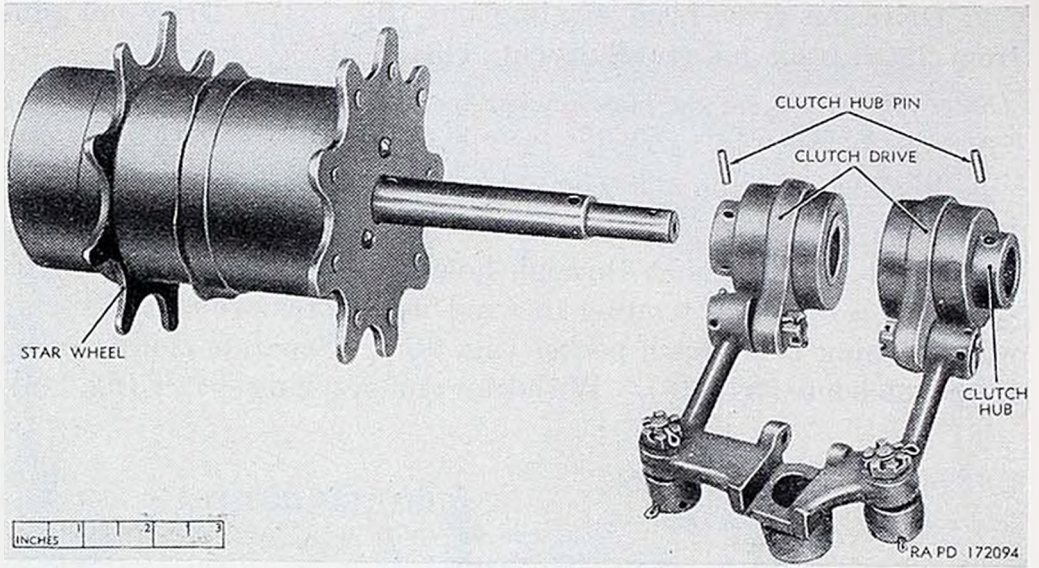

Figure 144. Clutch drive disassembled from driving mechanism.

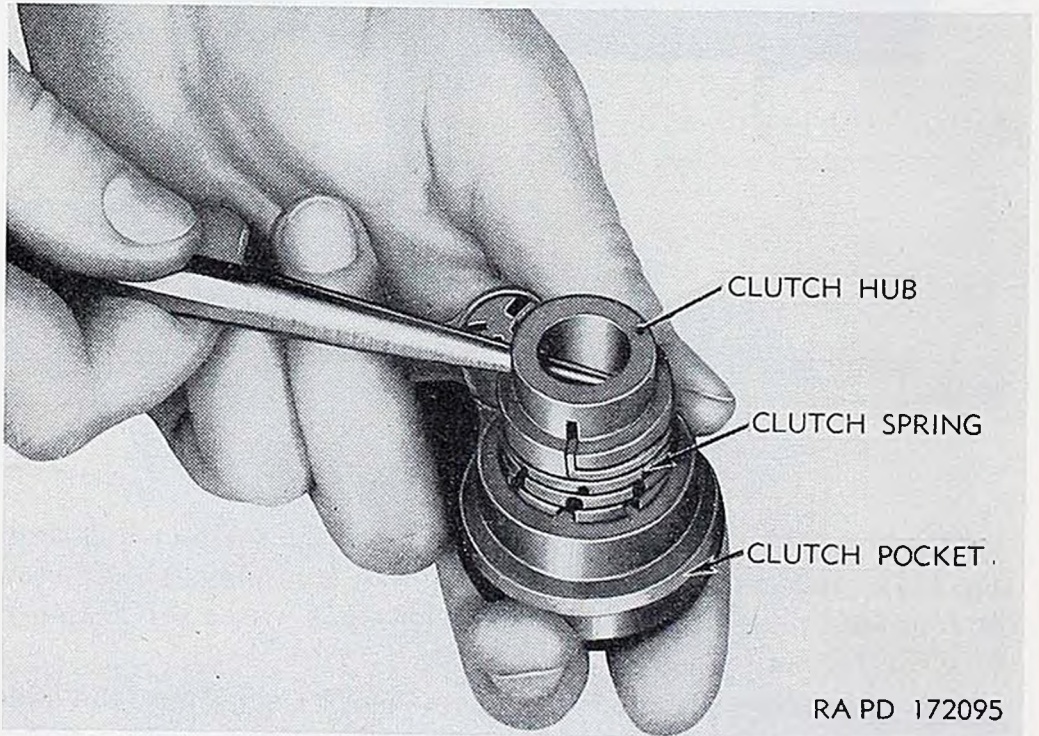

Figure 145. Removal of clutch spring.

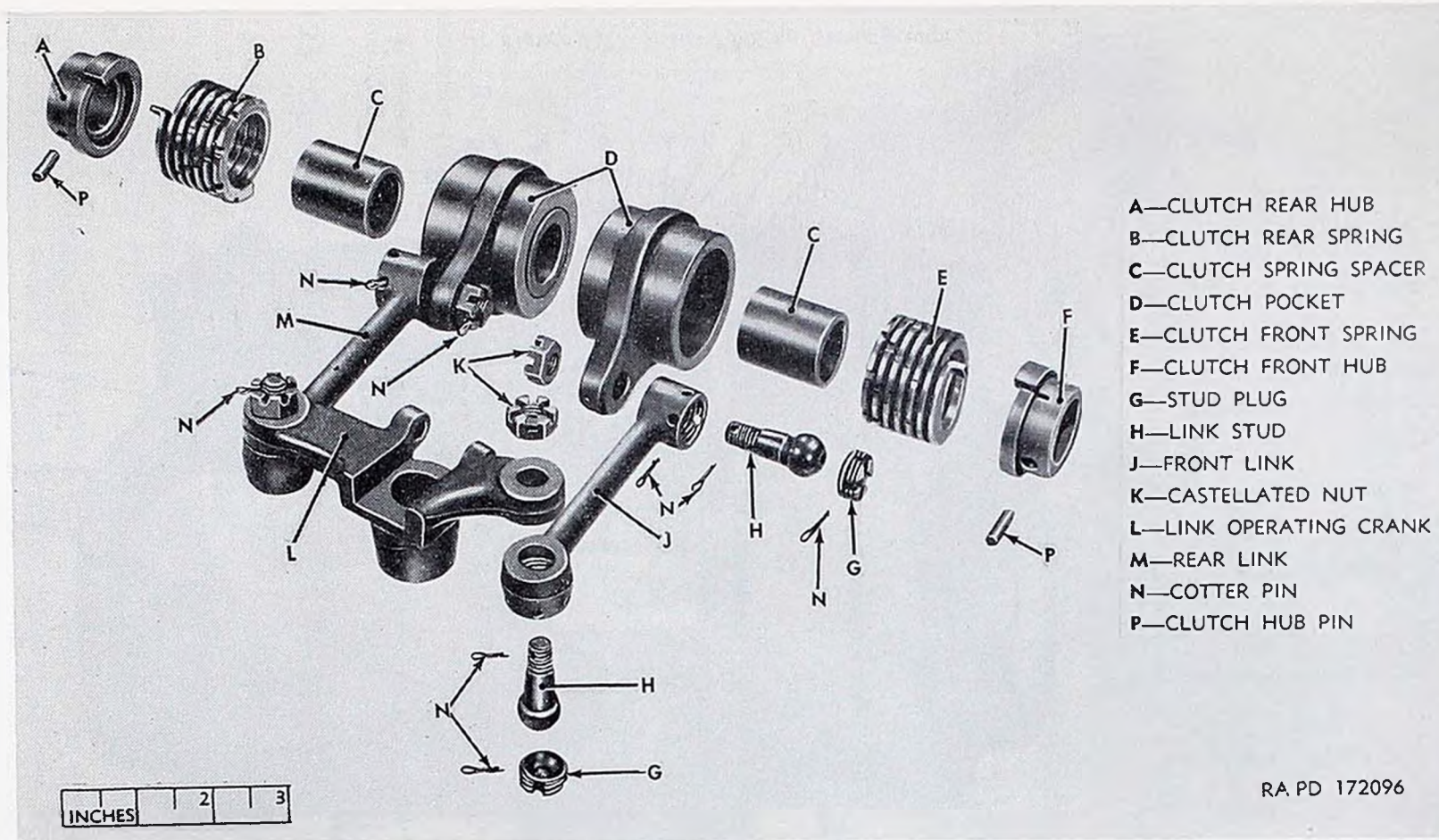

Figure 146. Clutch drive parts—feed mechanism AN-M2.

RESTRICTED

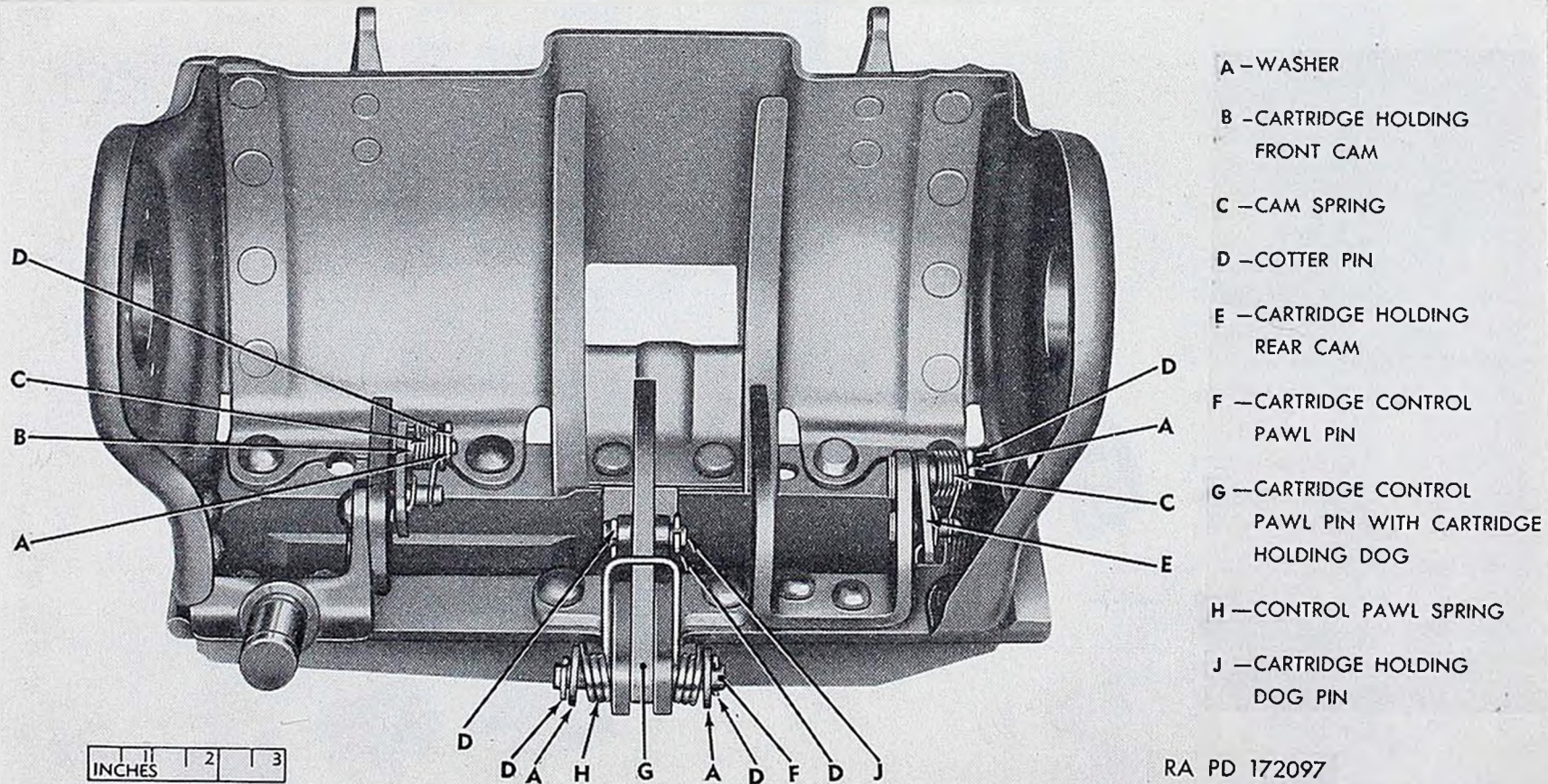

Figure 1/7. Disassembling frame group.

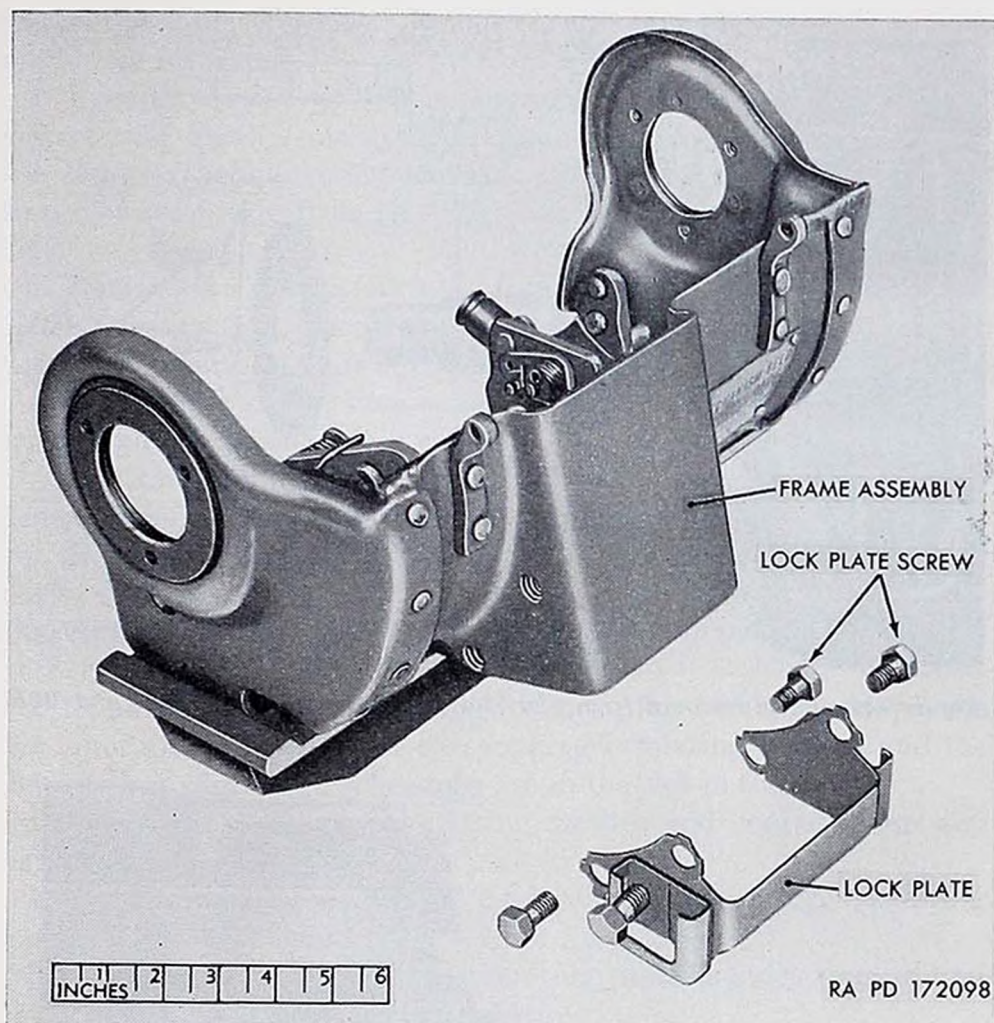

Figure 148. Removal of lock plate.

m. Remove the four lock plate screws and lock plate from frame assembly (fig. 148).

Note. Further disassembly of the feed mechanism by field maintenance is prohibited.

125. Disassembly of Feed Mechanisms M2E4 and M2E5

Note. The feed mechanism can be disassembled more easily and with less likelihood of distorting the feed mouth and link deflector while it is on the gun and with the operating lever disengaged from the gun.

Note. The operations described by the illustrations in this paragraph for the left-hand feed mechanism are also applicable to the right-hand feed mechanism.

a. Remove locking wire and the three screws and lock washers (fig. 149) on rear side of feed mechanism. Remove driving mechanism release nut retaining plate, driving mechanism release nut, and

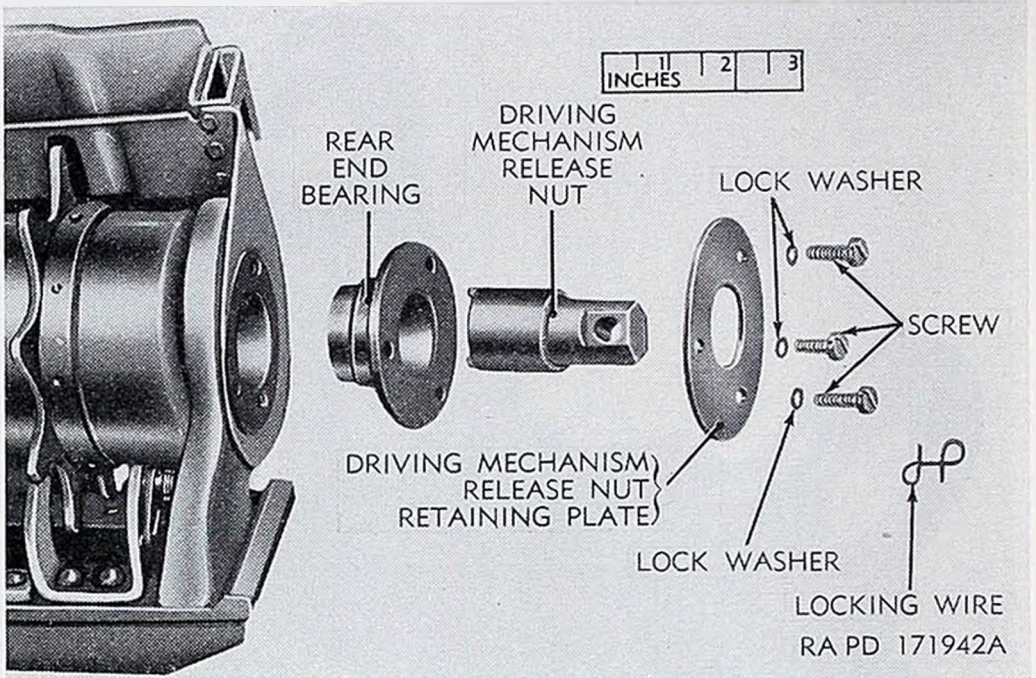

Figure 149. Parts removed from rear end of feed mechanisms M2E4 and M2E5.

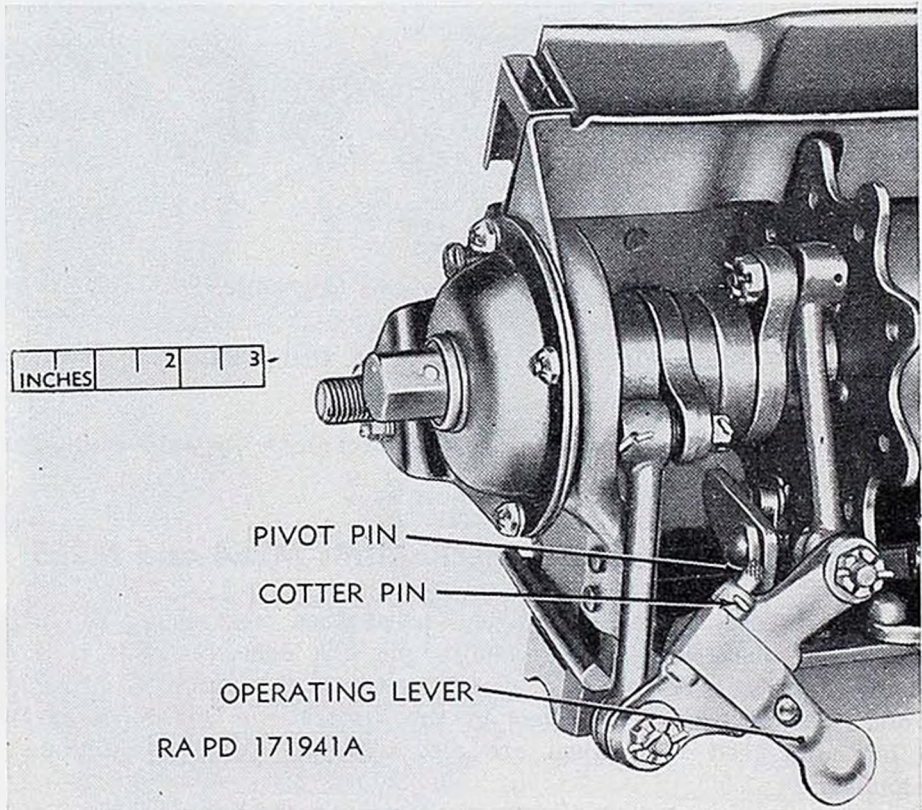

Figure 150. Removal of parts from front end of feed mechanisms M2E4 and M2E5.

RESTRICTED—Security Information

rear end bearing (fig. 149). Remove heater cartridge retaining screw and heater cartridge.

b. Unscrew receptacle cap and unsolder rubber insulated wire of contact ring brush from electrical connector receptacle (fig. 151).

c. Remove the four screws and lock washers and withdraw electrical connector receptacle from receptacle mounting bracket (figs. 150 and 151).

d. Remove the four safety nuts from contact ring brush mounting plate screws and remove the receptacle mounting bracket and contact ring brush mounting plate cover and gasket (fig. 151).

e. Cut and remove locking wire and remove the three contact ring brush mounting screws, plain washers, and plate screw locks (fig. 151).

f. Drive out winding nut pin and remove winding nut (fig. 151). Remove winding nut packing gasket from winding nut (fig. 151).

g. Remove contact ring locking plug (fig. 151). The plug is in slot in shaft.

h. Slide off winding nut stop washer and contact ring insulating washer (fig. 151).

i. Remove the two contact ring locking plug insulating stops, the two outer and the two inner contact ring insulating spacers, and the contact ring (fig. 151). The stops are in the slot in the shaft.

j. Remove contact ring insulating washer and contact ring stop washer (fig. 151).

k. Remove contact ring brush and contact ring brush insulating spacer (fig. 151).

l. Remove contact ring brush mounting plate, contact ring ground brush, and front end bearing (fig. 151).

m. Unlock feed chute adapter from feed frame and remove feed chute adapter (fig. 152). The feed chute adapters of feed mechanisms M2E4 and AN-M2 are alike (refer to fig. 141); the feed chute adapters of the feed mechanism M2E5 are shown in figure 152. Remove stripper cam adapter (fig. 152) (early production models).

n. Remove cotter pin, pull out pivot pin, and remove operating lever (fig. 150). Push link operating crank retainer upward and remove it.

o. Support driving mechanism with one hand and, with the other, disconnect link operating crank from link operating crank bracket (fig. 142) by pulling crank outward. Remove driving mechanism assembly and clutch drive group from feed frame.

Caution: Do not damage these parts by forcing them. In some instances, it may be necessary to remove one or two of the link ball studs from the operating crank in order to remove the crank.

p. Remove the four clutch hub screws from front and rear clutch hubs and slide off clutch drives with links and operating crank as a unit.

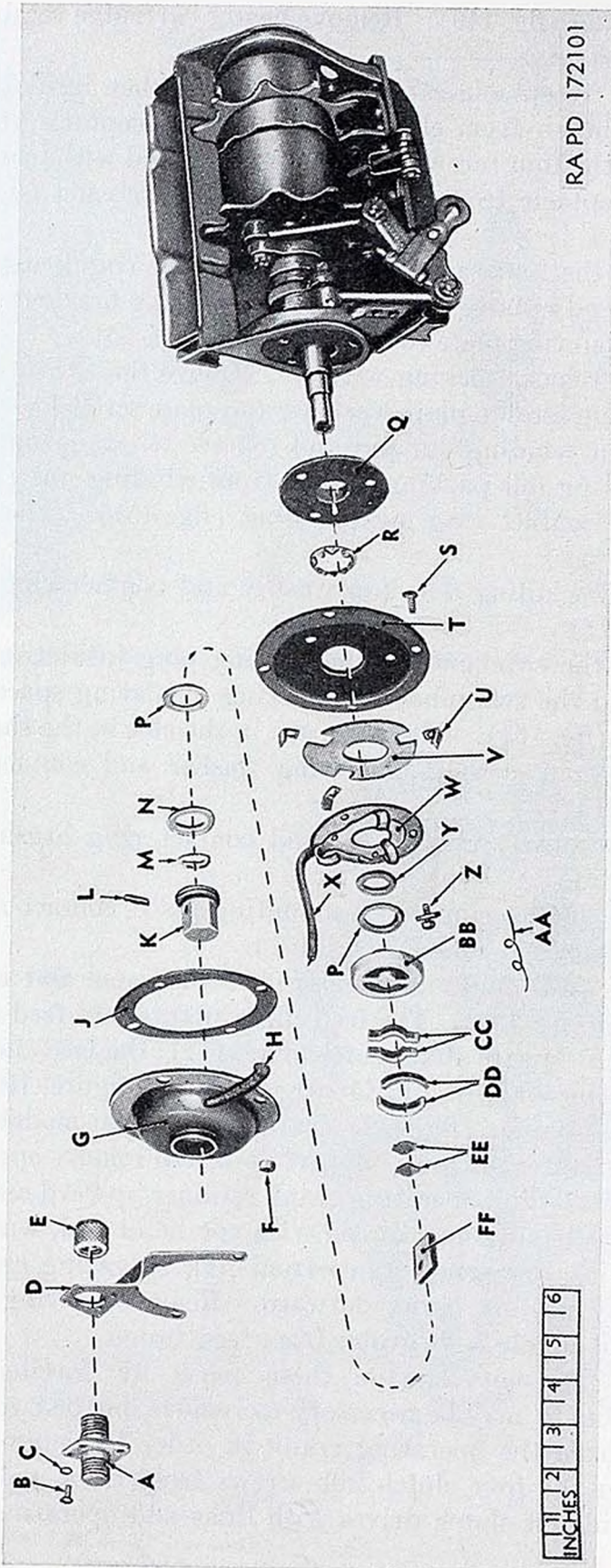

RA PD 172101

A—ELECTRICAL CONNECTOR RECEPTACLE.
 B—RECEPTACLE SCREW.
 C—RECEPTACLE LOCK WASHER.
 D—RECEPTACLE MOUNTING BRACKET.
 E—RECEPTACLE CAP.
 F—SAFETY NUT.
 G—CONTACT RING BRUSH MOUNTING PLATE COVER.
 H—WIRE FIBER GLASS INSULATING SLEEVE.
 J—CONTACT RING BRUSH MOUNTING PLATE FIBER GASKET.
 K—WINDING NUT.
 L—WINDING NUT PIN.
 M—WINDING NUT PACKING GASKET.
 N—WINDING NUT STOP WASHER.
 P—CONTACT RING INSULATING WASHER.
 Q—FRONT END BEARING.
 R—CONTACT RING GROUND BRUSH.
 S—CONTACT RING BRUSH MOUNTING PLATE SCREW.
 T—CONTACT RING BRUSH MOUNTING PLATE.
 U—CONTACT RING BRUSH MOUNTING PLATE SCREW LOCK.
 V—CONTACT RING BRUSH INSULATING SPACER.
 W—CONTACT RING BRUSH.
 X—CONTACT RING BRUSH RUBBER INSULATED WIRE.
 Y—CONTACT RING STOP WASHER.
 Z—CONTACT RING BRUSH MOUNTING SCREW AND PLAIN WASHER.
 AA—LOCKING WIRE.
 BB—CONTACT RING.
 CC—OUTER CONTACT RING INSULATING SPACER.
 DD—INNER CONTACT RING INSULATING SPACER.
 EE—CONTACT RING LOCKING PLUG INSULATING STOP.
 FF—CONTACT RING LOCKING PLUG.

Figure 151. Parts of heater contact group—feed mechanisms M2E4 and M2E5.

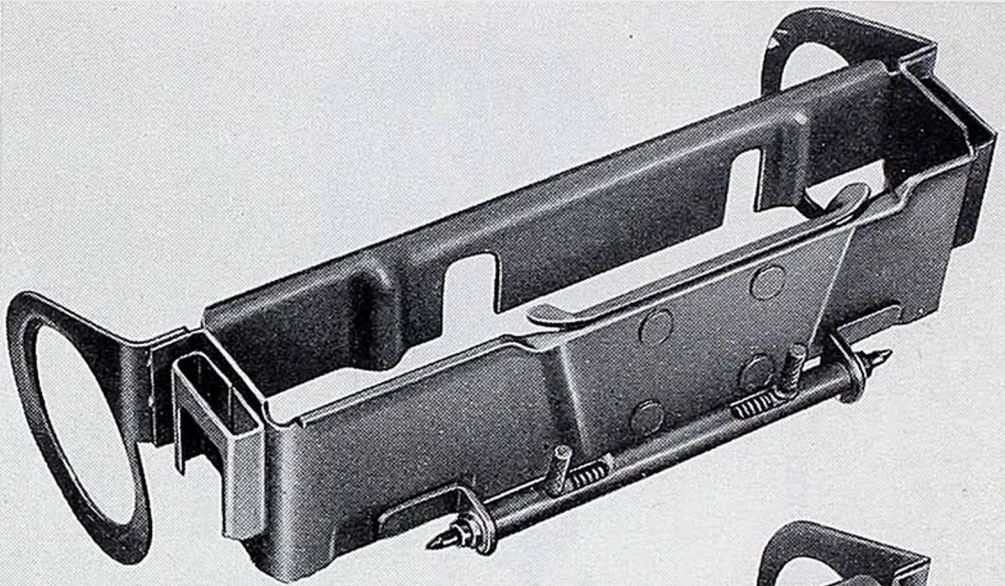

PRESENT MANUFACTURE

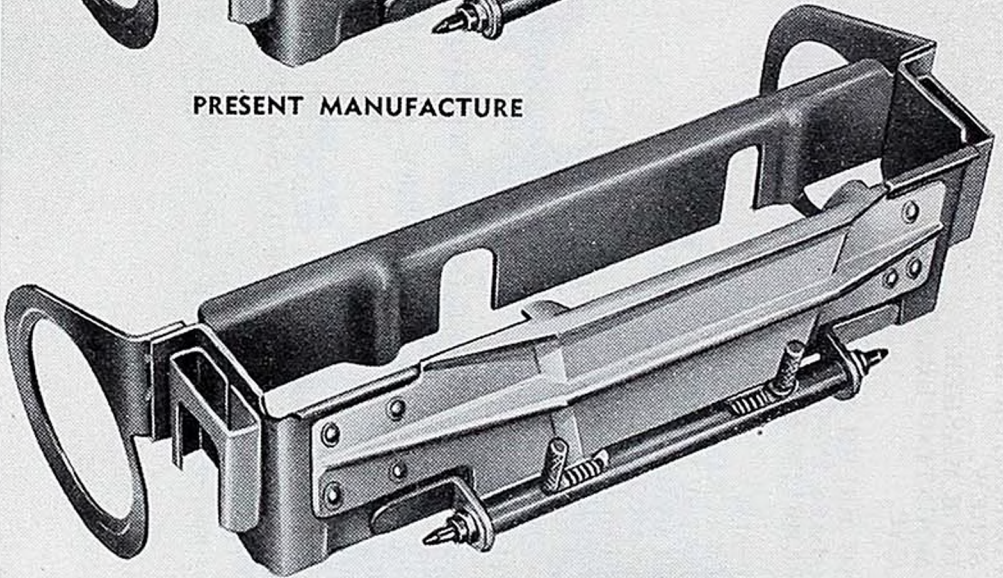

EARLY MODIFICATION

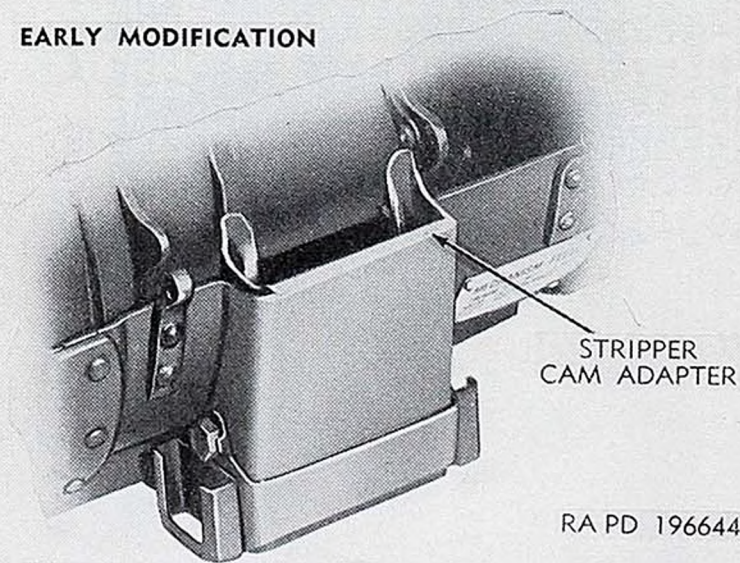

**STRIPPER
CAM ADAPTER**

RA PD 196644

Figure 152. Feed chute adapters and stripper cam adapter.

RESTRICTED

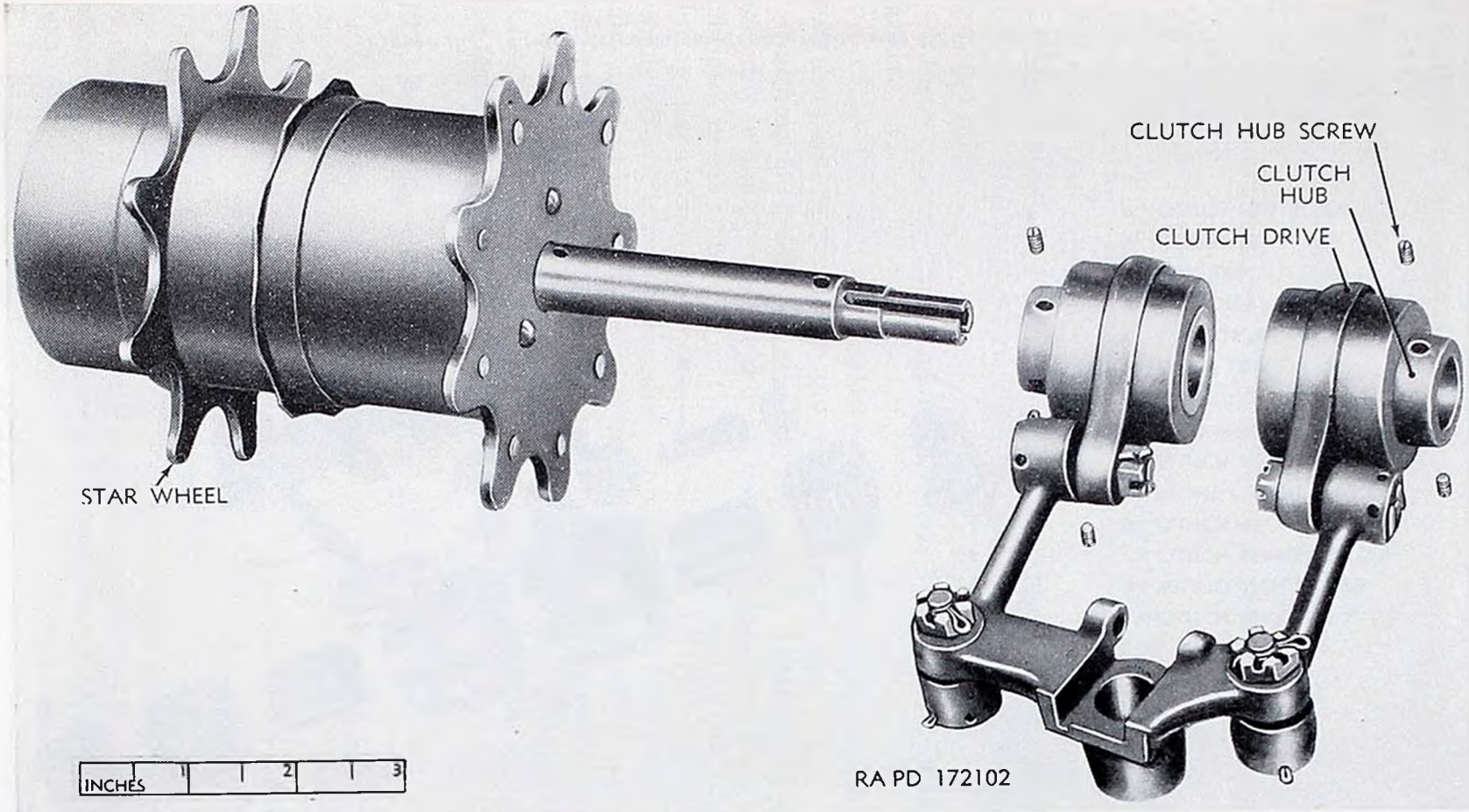

RESTRICTED—Security Information

Figure 153. Clutch drive disassembled from driving mechanism—feed mechanisms M2E4 and M2E5.

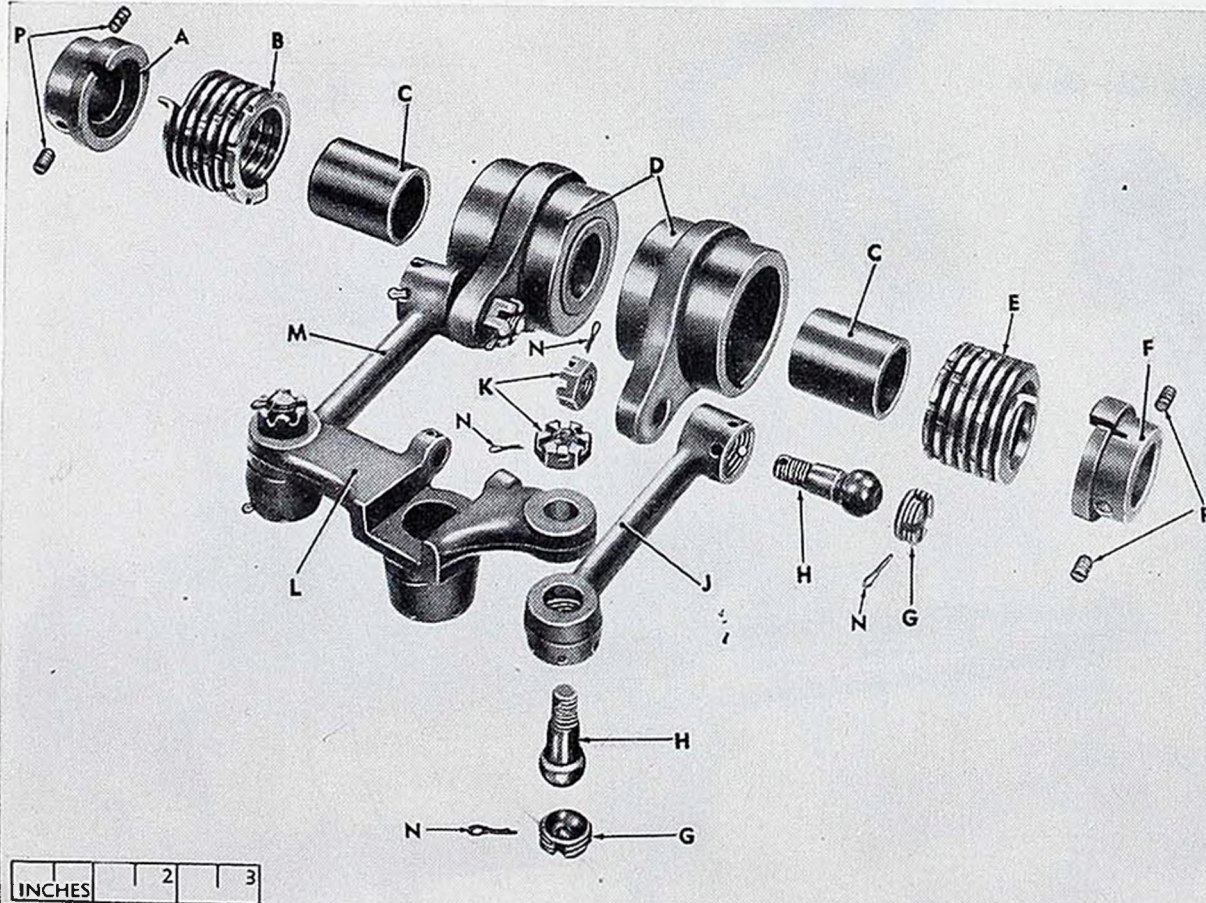

- A—CLUTCH REAR HUB
- B—REAR CLUTCH SPRING
- C—CLUTCH SPRING SPACER
- D—CLUTCH POCKET
- E—FRONT CLUTCH SPRING
- F—CLUTCH FRONT HUB
- G—STUD PLUG
- H—LINK STUD
- J—FRONT LINK
- K—CASTELLATED NUT
- L—LINK OPERATING CRANK
- M—REAR LINK
- N—COTTER PIN
- P—CLUTCH HUB SCREW

RA PD 172103

Figure 154. Clutch drive parts—feed mechanisms M2E4 and M2E5.

RESTRICTED—Security Information

g. For remainder of disassembly, refer to paragraph 124*i* through *m* and refer to figure 154.

126. Maintenance

a. Check the outside of the feed mechanism for loose or broken parts.

b. Dents in the frame assembly or feed cover will make them unserviceable.

c. Stone burs from feed mouth.

Caution: Do not remove metal from surfaces of feed mouth as cartridge control will be impaired by change of contour.

d. Check star wheels for rough spots.

e. Check for binding or backlash at ball joints of link studs and link stud plugs. Binding and backlash may be eliminated by adjusting link stud plugs.

f. Inspect clutch drive. Remove all burs from interior of clutch pocket.

g. Check the cartridge guides, control pawl, and holding dog for burs and rough spots. Clean and oil these components.

Caution: Do not dip the complete feeder or its driving mechanism assembly in any cleaning fluid or oil because such fluids will ruin the lubricant in the unit. The driving mechanism assembly is lubricated during manufacture and no provision is made for cleaning the assembly after it is riveted together. In addition, the mechanism contains an electric heater cartridge in its shaft and serious damage will result to this mechanism if it is dipped in cleaning fluid or oil.

h. Link ejection chute should be $1\frac{1}{8}$ to $1\frac{3}{16}$ inches wide; if opening is less, increase it to this dimension by bending the deflector toward the feeder mouth.

127. Assembly of Feed Mechanism AN-M2

Note. The feed mechanism can be assembled more easily and with less likelihood of distorting the feed mouth and link deflector while the frame is mounted on the gun.

Note. The operations illustrated in this paragraph whether with a right-hand or left-hand feed mechanism are applicable to both types.

a. Clean and oil all parts before assembling.

b. Assemble cartridge holding dog to cartridge control pawl by means of the cartridge holding dog pin, so that convex side of dog is adjacent to concave side of pawl, and secure dog with the two cotter pins (fig. 155).

RESTRICTED—Security Information

c. Hold cartridge control pawl with cartridge holding dog so that dog is facing toward mouth of frame, as shown in figure 156. Hold cartridge pawl spring so that open ends of spring are under the control pawl bracket and upper end of spring is on top of cartridge control pawl (fig. 156). Align control pawl, bracket, and spring and secure them with cartridge control pawl pin, washers, and cotter pins (fig. 147).

d. The cartridge holding cams and springs for left-hand and right-hand feed mechanisms are different. Before installing cartridge holding cams and springs, select proper cams and springs for left-hand or right-hand feed mechanism by referring to figure 157.

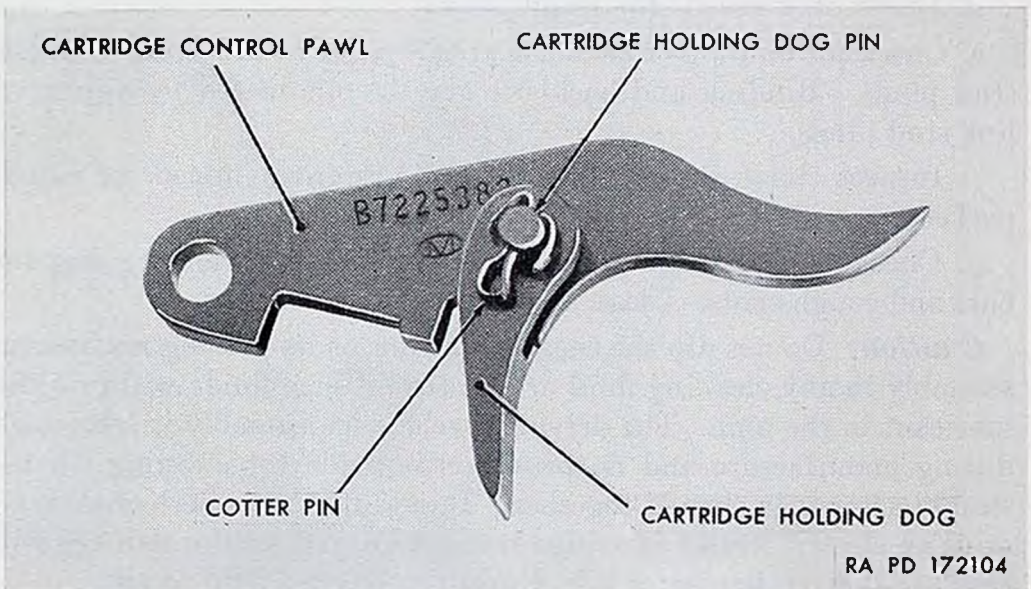

Figure 155. Cartridge holding dog assembled to cartridge control pawl.

e. Assemble cartridge holding cam spring so that offset end of the spring is anchored in small hole and coil fits onto hub of cartridge holding front cam (fig. 157). Assemble cartridge holding front cam to front cartridge guide so that flat side of cam is toward the cartridge guide, longer pivot stud fits into the hub of the cam, and shorter pivot stud fits into the elongated slot in the cam, as shown in figure 158. Snap other end of spring into groove on lower side of shorter pivot stud, as shown in figure 158. Assemble washer and secure it with cotter pin (fig. 147). Similarly, assemble cartridge holding rear cam.

f. Before assembling clutch drive group, select correct link operating crank, links, and clutch springs for left-hand or right-hand feed mechanism in accordance with the following instructions:

- (1) For right-hand feed mechanism, the link operating crank has a slot (for the operating lever) sloping to the right and

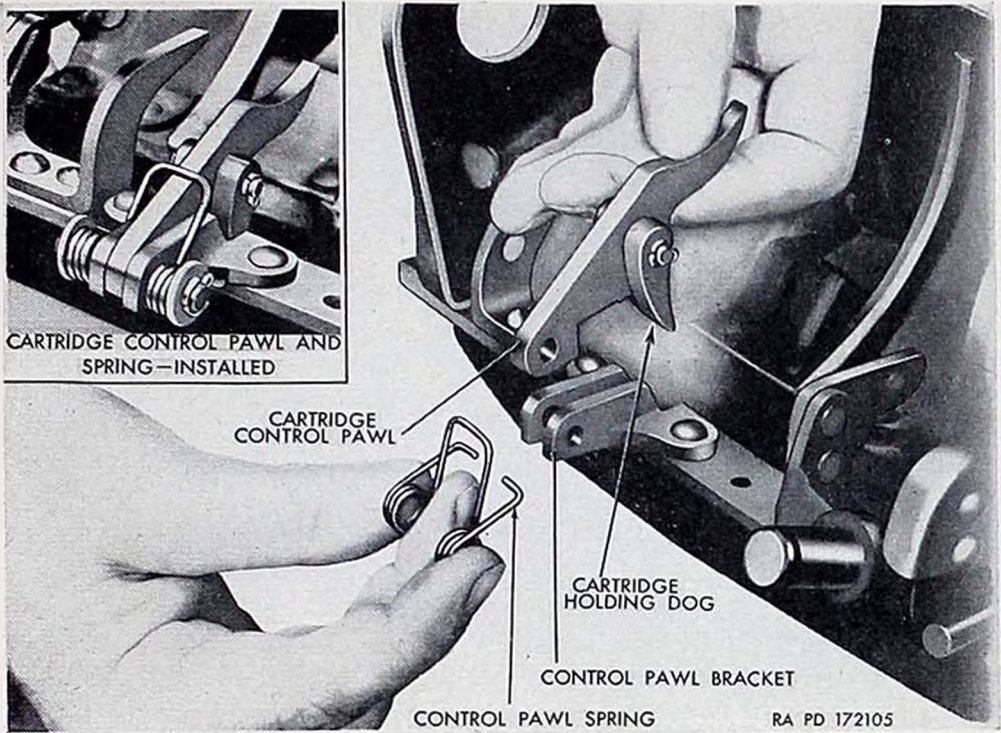

Figure 156. Installing cartridge control pawl.

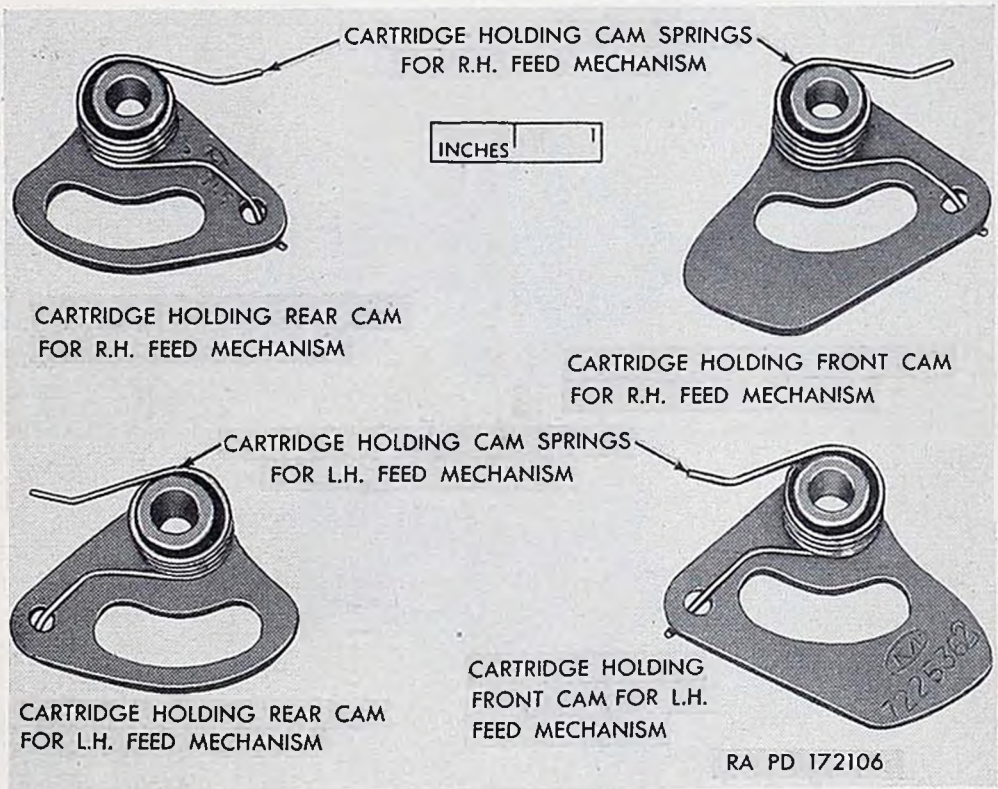
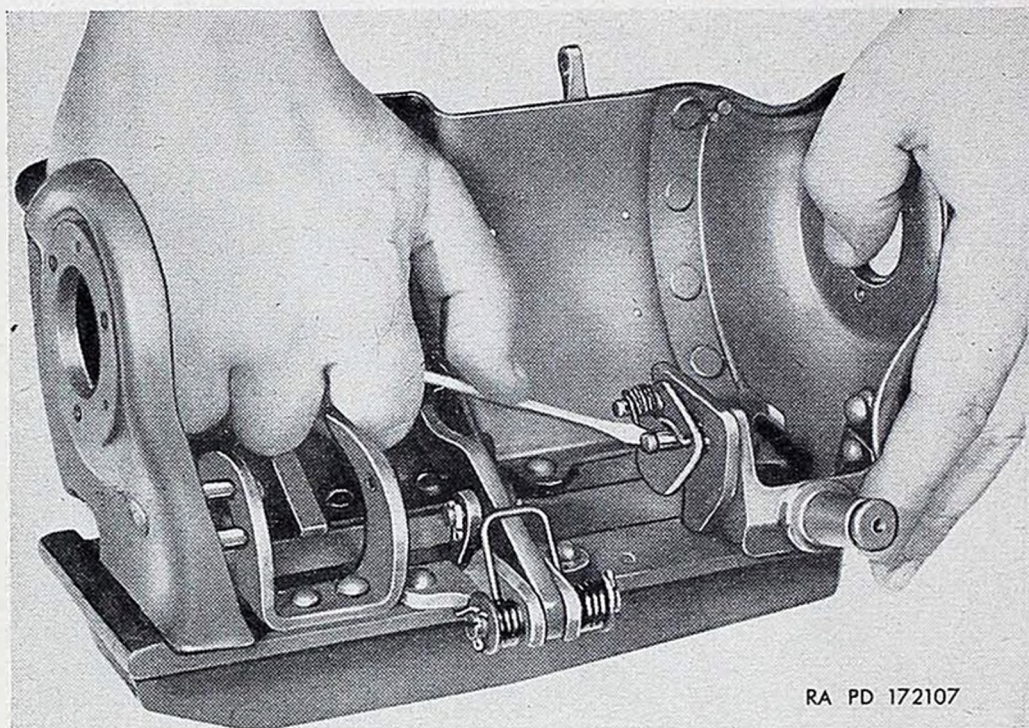
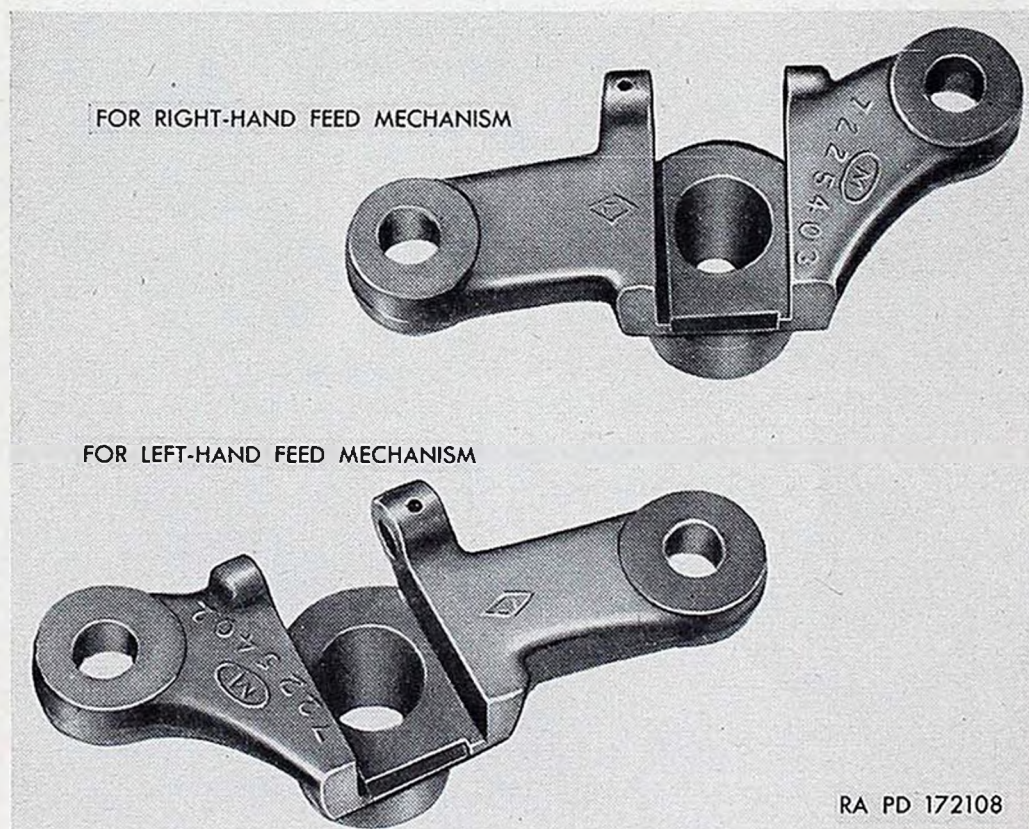

Figure 157. Cartridge holding cams and springs for left-hand and right-hand feed mechanisms.



RA PD 172107

Figure 158. Installing cartridge holding front cam with spring.



RA PD 172108

Figure 159. Link operating cranks for left-hand and right-hand feed mechanisms.

RESTRICTED—Security Information

for a left-hand feed mechanism, the slot in the crank slopes to the left, as shown in figure 159. These cranks are not interchangeable.

- (2) For a right-hand feed mechanism, the front link is cupped downward at the lower end and to the right at the upper end, while the rear link is cupped downward at the lower end and to the left at the upper end, as shown in figure 160. For a left-hand feed mechanism, the front link is cupped downward at the lower end and to the left at the upper end, while

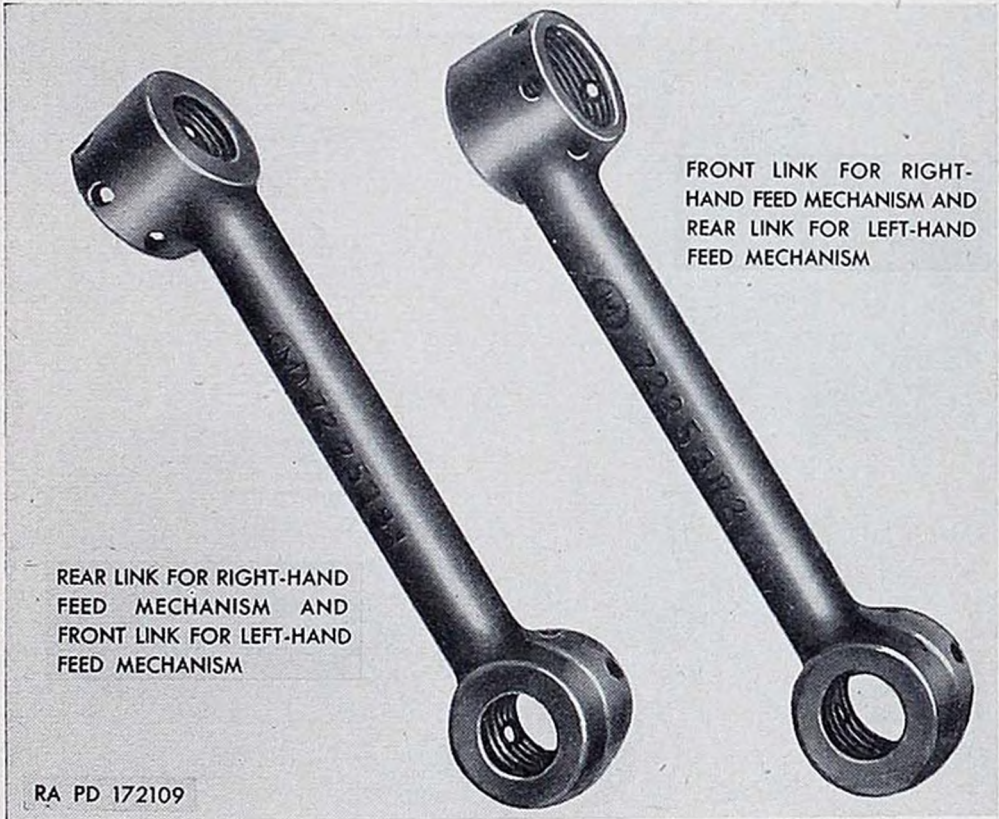

Figure 160. Links for left-hand and right-hand feed mechanisms.

the rear link is cupped downward at the lower end and to the right at the upper end, as shown in figure 160. The front link of a right-hand feed mechanism is interchangeable with the rear link of a left-hand feed mechanism. In a like manner, the rear link of a right-hand feed mechanism is interchangeable with the front link of a left-hand feed mechanism.

- (3) For a right-hand feed mechanism, the front clutch spring is left-hand winding, while the rear clutch spring is right-hand winding, as shown in figure 161. For a left-hand feed mech-

RESTRICTED—Security Information

anism, the front clutch spring is right-hand winding, while the rear clutch spring is left-hand winding, as shown in figure 161. The front clutch spring of a right-hand feed mechanism is interchangeable with the rear clutch spring of a left-hand feed mechanism; the rear clutch spring of a right-hand feed mechanism is interchangeable with the front clutch spring of a left-hand feed mechanism.

g. Insert a link stud (threaded end leading) through one of the threaded cups of the front link and into front hole of link operating

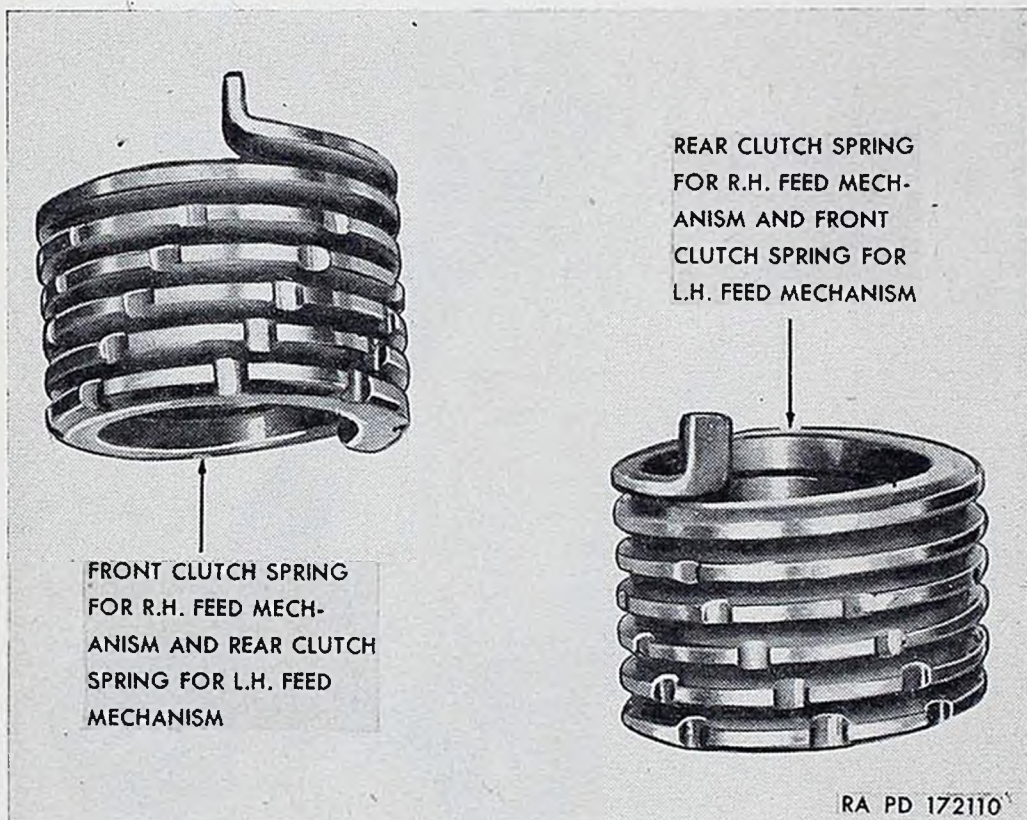

Figure 161. Clutch springs for left-hand and right-hand feed mechanisms.

crank, from back side of the link operating crank (fig. 146). Do not attempt to force stud into hole from front side of crank because hole is tapered to receive stud from back side only. With a soft hammer, drive stud into crank, taking care not to damage threads. Install castellated nut and cotter pin on link stud (fig. 146). Similarly, assemble rear link to link operating crank.

h. Insert a link stud through other threaded opening of front link (fig. 146) and into clutch pocket from cupped side of clutch pocket (fig. 146). Do not attempt to force stud into position from uncupped side because hole is tapered to receive stud from cupped side only. With a soft hammer, drive stud into position, taking care not to

RESTRICTED—Security Information

damage threads. Install castellated nut and cotter pin on link stud (fig. 146). Similarly, assemble rear link to rear clutch pocket.

i. Screw in each of the four stud plugs (cupped end leading) tightly, then back off plugs (usually about one turn) until there is no binding or play in ball joint, and secure plugs to links with cotter pins (fig. 146).

j. Assemble clutch front spring to clutch front hub and place a clutch spring spacer into clutch front spring (figs. 146 and 162). Insert a drift punch through holes of hub and twist and press spring (with hub) into position in clutch front pocket, as shown in figure 145. Similarly, assemble clutch rear hub, clutch rear spring, and clutch spring spacer in clutch rear pocket.

k. Assemble clutch drive on drive shaft, with rear pocket leading, drive in the two clutch hub pins (figs. 143 and 144), and stake them. Install winding nut (fig. 143), drive in new rivet (fig. 143), and peen it.

l. Support driving mechanism assembly in feed frame so that winding nut extends through hole in front and slide link operating crank onto the link operating crank bracket (fig. 142).

m. Slide the link operating crank retainer (fig. 140) into position in groove of bracket. Arms of retainer should point downward. Install operating lever and secure with pivot pin and cotter pin (fig. 139).

n. Place feed chute adapter (fig. 141) in position on frame and lock it to frame.

o. Install rear end bearing, driving mechanism release nut, and driving mechanism release nut retaining plate (fig. 136). Secure plate and bearing to frame with three screws and secure the three screws with locking wire (figs. 135 and 136).

p. Install front end bearing and plate and fasten bearing and plate to frame with three screws (fig. 138). Secure the three screws with locking wire (fig. 137).

q. Install lock plate with four lock plate screws (fig. 148).

128. Assembly of Feed Mechanisms M2E4 and M2E5

a. Proceed as in paragraph 127*a* through *j*.

b. Assemble clutch drive on drive shaft, with clutch rear pocket leading, as shown in figure 153, align the holes, and screw in the four clutch hub screws (fig. 153).

Note. Insert a $\frac{3}{8}$ -inch rod into shaft to make certain that screws do not protrude into the inner diameter of shaft.

c. Support driving mechanism in feed frame so that shaft extends

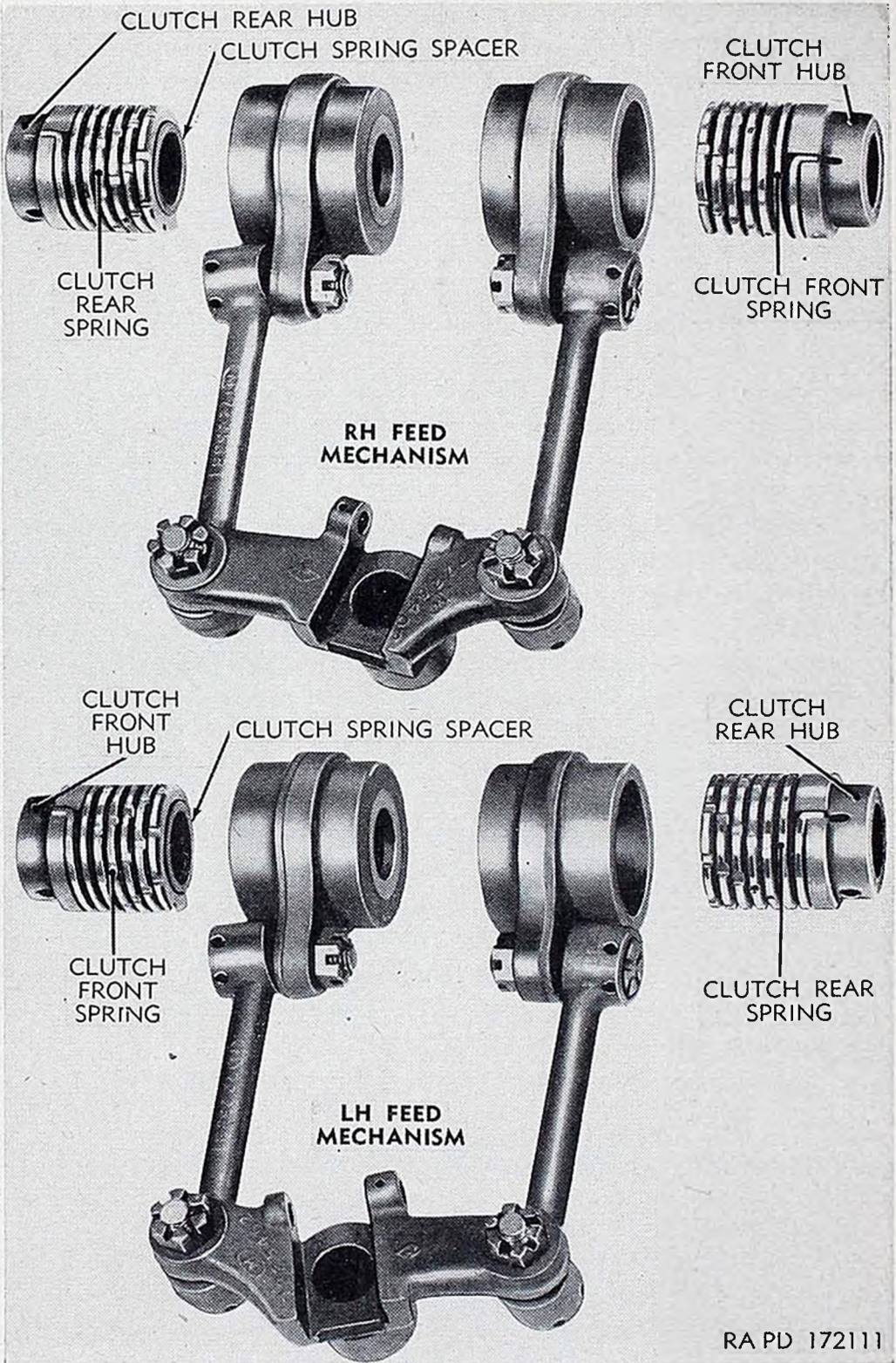

Figure 162. Clutch drives for left-hand and right-hand feed mechanisms.

RESTRICTED—Security Information

through hole in front and slide link operating crank onto the link operating crank bracket (fig. 142).

d. Slide link operating crank retainer (fig. 140) into position in groove of bracket. The arms of the retainer should point downward. Install operating lever and secure with pivot pin and cotter pin (fig. 150).

e. Install stripper cam adapter (fig. 152) (if used), place feed chute adapter (fig. 152) in position, and lock it to frame.

f. Install heater cartridge and cartridge heater retaining screw; stake in two places and shellac. Install rear end bearing, driving mechanism release nut, and driving mechanism release nut retaining plate, fasten plate and bearing to frame assembly with three screws, and secure screws with locking wire (fig. 149).

g. Install front end bearing, contact ground brush, contact ring brush mounting plate, contact ring brush insulating spacer, three contact ring brush mounting plate screw locks, contact ring stop washer and insulating washer, contact ring brush, contact ring, and outer and inner contact ring insulating spacers (fig. 151). Aline the holes and install the three contact ring brush mounting plate screws and secure each screw to the lock with locking wire (fig. 151).

h. Insert the two contact ring locking plug insulating stops and the contact ring locking plug (fig. 151) into slot in driving mechanism shaft.

i. Install contact ring insulating washer and winding nut stop washer (fig. 151).

j. Install winding nut packing gasket around edge of winding nut and install winding nut (fig. 151). Aline hole in plug with hole in shaft and install winding nut pin (fig. 151). Stake pin.

k. Feed the contact ring brush rubber insulated wire through the wire fiber glass insulating sleeve on the contact ring brush mounting plate cover (fig. 151). Install contact ring brush mounting plate fiber gasket and contact ring brush mounting plate cover on the contact ring brush mounting plate screws (fig. 151). The sleeve should be positioned toward the bottom of the feed mechanism.

l. Install electrical connector receptacle on receptacle mounting bracket and fasten with four receptacle screws and receptacle lock washers (fig. 151). Push receptacle cap onto sleeve, with internal threads of cap positioned to engage the external threads of the electrical connector receptacle (fig. 151). Silver-solder insulated wire to receptacle and screw on receptacle cap (fig. 151). Maximum height of silver solder connection should not exceed 0.062 inch. Secure receptacle mounting bracket and contact ring brush mounting plate cover with four safety nuts (fig. 151).

CHAPTER 5

AMMUNITION

129. General

Ammunition for 20-mm automatic guns M24, M24A1, and M24E2 is issued in the form of complete rounds of fixed ammunition. The round consists of an electric primer and propelling charge contained in a cartridge case that is crimped rigidly to the projectile. The term "fixed" used in conjunction with ammunition signifies that the propelling charge is fixed (not adjustable) and that the round is loaded into the gun as a unit. For more complete information, refer to TM 9-1901.

130. Firing Tables

Firing tables for 20-mm automatic guns M24, M24A1, and M24E2, compiled for use in designing sights, are not available for general distribution.

131. Classification

The ammunition authorized for use in this gun is classified as high-explosive incendiary, incendiary, armor-piercing with tracer, target-practice, or drill, depending on the type of projectile.

a. High-explosive incendiary projectiles are comparatively thin-walled projectiles containing both an incendiary mixture and a high-explosive bursting charge. It is fuzed with a point-detonating fuze.

b. Incendiary projectiles are loaded only with an incendiary mixture and have no fuze.

c. Armor-piercing with tracer projectiles are solid projectiles fitted with a windshield over the nose and a tracer element in the base to provide a means for observing the path of the projectile in flight.

d. Armor-piercing incendiary projectiles are solid shot fitted with a steel adapter and an aluminum alloy nose. The nose is loaded with an incendiary mixture.

e. Target-practice projectiles are inert. The target-practice rounds simulate the service rounds in size, weight, and shape.

f. Drill ammunition is completely inert and is intended only for practice in loading and handling.

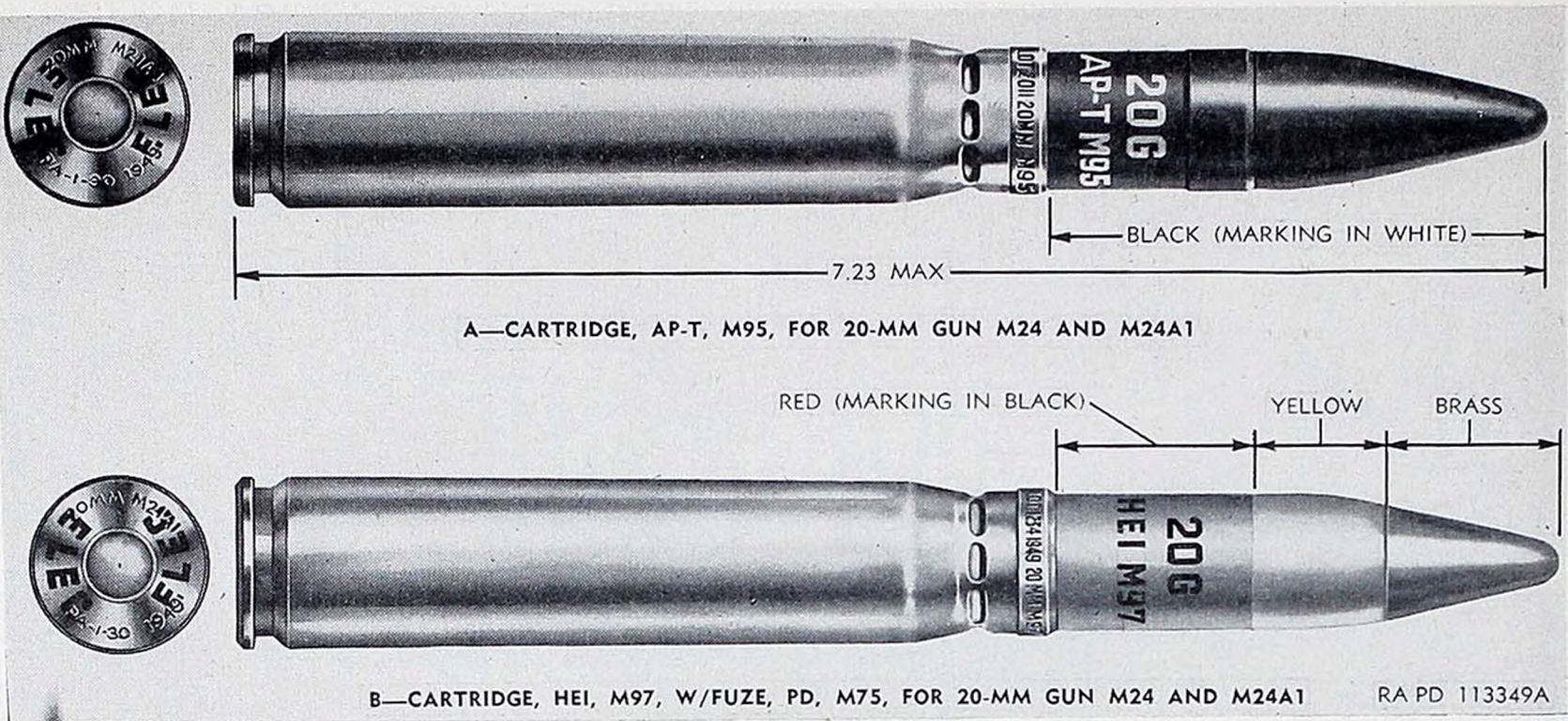

Figure 163. Armor-piercing with tracer and high-explosive incendiary cartridge for guns M24, M24A1, and M24E2.

132. Identification

a. General. Ammunition and ammunition components are completely identified by the painting and marking (including an ammunition lot number) that appears on all original packing containers and, when practicable, on the items themselves, as shown on figures 163 and 164. Links are shown in figure 105.

b. Model. To identify a particular design, a model designation is assigned at the time the item is classified as an adopted type. This model designation becomes an essential part of the standard nomenclature and is included in the marking on the item. The present method of model designation consists of the letter "M" followed by an Arabic numeral. Modifications are indicated by adding the letter "A" and appropriate Arabic numeral. Thus, "M18A3" indicates the third modification of an item for which the original designation was "M18." Similarly, a system applied to development items involves the use of a "T" designation to indicate the basic design and an "E" to indicate modifications thereof. Thus, T21E1 would indicate the first modification of a development item originally designated T21.

c. Ammunition Lot Number. When ammunition is manufactured, an ammunition lot number, which becomes an essential part of the marking, is assigned in accordance with pertinent specifications. This lot number is stamped or marked on every loaded complete round and on all packing containers. It is required for all purposes of record, including reports on condition, functioning, or accidents in which ammunition may be involved. In any one lot of ammunition, the components used in the assembly are manufactured under as nearly identical conditions as practicable. To provide for the most uniform functioning, all the rounds of any one lot of fixed ammunition consist of projectiles of one lot number, fuzes of one lot number, primers of one lot number, and propellant powder of one lot number. To obtain the greatest accuracy when firing, successive rounds should consist of one ammunition lot whenever practicable.

d. Painting. Ammunition is painted primarily to prevent rust and to provide, by the color, a means of identification as to type, due consideration being given to requirements for camouflage. The color scheme is as follows (figs. 163 and 164) :

- Armor-piercing incendiary----- Blue nose; black body; marking in white.
- Armor-piercing with tracer----- Black; marking in white.
- High-explosive incendiary----- Brass fuze; yellow ogive, red body, marking in black.
- Incendiary----- Blue nose; gray body, marking in black.
- Target-practice----- Black; marking in white.

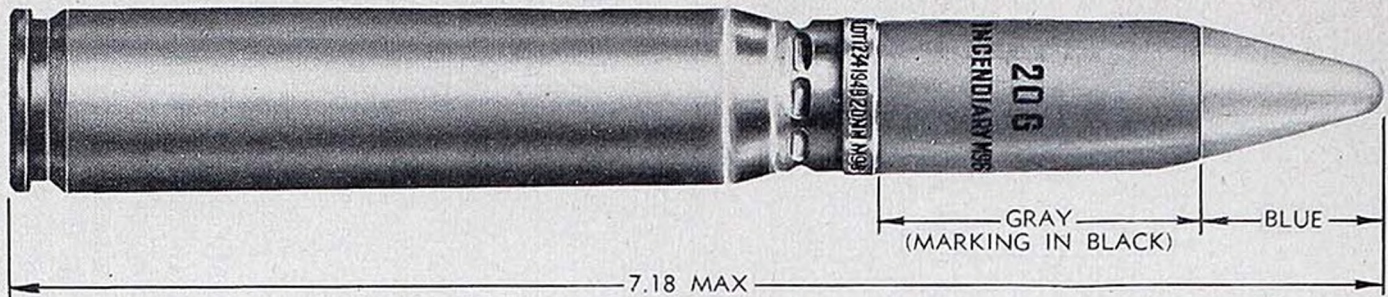

A—CARTRIDGE, INCENDIARY, M96, FOR 20-MM GUN M24 AND M24A1



B—CARTRIDGE, TP, M99, FOR 20-MM GUN M24 AND M24A1



RA PD 113350A

Figure 164. Incendiary and target-practice cartridges for guns M24, M24A1, and M24E2.

RESTRICTED—Security Information

e. Marking. The components of each round of ammunition described herein are marked as follows:

- (1) *On projectile (stenciled).*
 - (a) Type of shell.
 - (b) Caliber and model designation.
 - (c) Loader's initials.
 - (d) Ammunition lot number.
- (2) *On projectile (stamped in rotating band of new rounds).*
 - (a) Projectile lot number.
 - (b) Year of manufacture.
 - (c) Manufacturer's initials or symbol.
 - (d) Caliber and model designation.
- (3) *On head of cartridge case.*
 - (a) *Stenciled.* The letters "ELEC."
 - (b) *Stamped in metal.*
 1. Caliber and model designation of case.
 2. Manufacturer's initials or symbol.
 3. Lot number of cartridge case.
 4. Year of manufacture, in full.
- (4) *On fuze (stamped in metal).*
 - (a) Model and designation of fuze.
 - (b) Manufacturer's initials or symbol.
 - (c) Loader's lot number.
 - (d) Month and year of loading.

f. Wax Coating. At the time of manufacture, a thin coating of wax is applied to the cartridge case (head and primer included) of each complete round. This wax coating is required for the proper functioning of the gun.

133. Care, Handling, and Preservation

a. Ammunition is packed to withstand conditions ordinarily encountered in the field. Care must be observed to keep packings from becoming broken or damaged. All broken packings must be repaired immediately and careful attention given to the transfer of all marking to the new parts.

b. When it is necessary to leave ammunition in the open, raise it on dunnage at least 6 inches from the ground and cover it with a double thickness of paulin, leaving enough space for the circulation of air. Where practicable, dunnage strips should be placed under each layer of boxes. Suitable trenches should be dug to prevent water from running under the pile.

c. Since explosives are adversely affected by moisture and high temperature, due consideration should be given to the following:

RESTRICTED—Security Information

- (1) Do not break the moisture-resistant seals until ammunition is to be used. Ammunition removed from airtight containers, particularly in damp climates, is apt to corrode, thereby rendering the ammunition unserviceable.
- (2) Protect ammunition from high temperature and direct rays of the sun. More uniform firing is obtained if the rounds are at the same temperature.

d. Do not attempt to disassemble the complete round or any of its components.

e. Do not handle duds. Because their fuzes may be armed, duds are extremely dangerous. They will not be moved or touched but will be destroyed in place in accordance with TM 9-1900.

Note. Explosive ammunition must be handled with care at all times. The explosive elements in primers and fuzes are particularly sensitive to undue shock and high temperature. Electric primers are sensitive to electrical energy; care should be exercised to prevent the ammunition from coming in contact with electrical wiring or other sources of electricity. Boxes containing ammunition should not be dropped, thrown, tumbled, or dragged.

134. Authorized Rounds

a. General. Ammunition authorized for use in 20-mm automatic guns M24, M24A1, and M24E2 is listed in table VIII. Standard nomenclature, which is used in the listing, completely identifies the ammunition, except for ammunition lot number.

b. Description of Rounds. Rounds for 20-mm automatic guns M24, M24A1, and M24E2 are assembled with electric primers. All have a purple annulus about the primer in the head of the cartridge case to indicate this fact. The service and target-practice rounds are of the same length and weight, except for the incendiary round which is slightly lighter in weight than the other rounds. When fired with a muzzle velocity of 2,730 fps from a stationary weapon, the projectiles have matched ballistics, their trajectories intersecting at 1,000 yards after approximately 1.66 seconds of flight.

c. Components. Round of current manufacture are assembled with—

CASE, cartridge, 20-mm, M21A1; weight 0.205 pound.

CHARGE, propelling, 20-mm, M12; weight 0.07 pound.

PRIMER, electric, M52A2 or M52A3; weight 0.003 pound.

135. Preparation for Firing

After removal from packing materials, linked cartridges for these automatic guns are ready for firing, except that they should be checked for proper alinement before firing. Carton packed cartridges for

RESTRICTED—Security Information

Table VIII. Authorized Rounds for 20-MM Automatic Guns M24, M24A1, and M24E2

Standard nomenclature	Complete round		Projectile weight as fired (lb)	Action of fuze
	Weight (lb)	Length (in)		
SERVICE AMMUNITION ¹				
CARTRIDGE, AP, M95, for 20-mm guns M24, M24E2, and M24A1 (w/electric primer M52A3). ²	-----	-----	-----	None
CARTRIDGE, API, T21E1, for 20-mm guns M24, M24E2, and M24A1 (w/electric primer M52A3).	-----	-----	-----	None
CARTRIDGE, AP-T, M95, for 20-mm guns M24, M24E2, and M24A1 (w/electric primer M52A2 or M52A3). ³	0. 57	7. 23	0. 29	None
CARTRIDGE, AP-T, M95A1, for 20-mm guns M24, M24E2, and M24A1 (w/electric primer M52A3). ³	. 57	7. 23	. 29	None
CARTRIDGE, HEI, M97, w/fuze, PD, M75, for 20-mm guns M24, M24E2, and M24A1 (w/electric primer M52A2).	. 57	7. 23	. 29	Superquick
CARTRIDGE, HEI, M97, w/fuze, PD, T196E4, for 20-mm guns M24, M24E2, and M24A1 (w/electric primer M52A3).	. 57	7. 23	. 29	Superquick
CARTRIDGE, incendiary, M96, for 20-mm guns M24, M24E2, and M24A1 (w/electric primer M52A2 or M52A3).	. 56	7. 18	. 28	None
TARGET PRACTICE AMMUNITION ¹				
CARTRIDGE, TP, M99, for 20-mm guns M24, M24E2, and M24A1 (w/electric primer M52A2 or M52A3).	0. 57	7. 23	0. 29	None
DRILL AMMUNITION ¹				
CARTRIDGE, drill, M18A2, for 20-mm guns AN-M2, M3, M24, M24E2, and M24A1.	0. 57	7. 22	-----	None
CARTRIDGE, drill, M18A3, for 20-mm guns AN-M2, M3, M24, M24E2, and M24A1.	. 57	7. 22	-----	None

See footnotes at end of table.

RESTRICTED—Security Information

Table VIII. Authorized Rounds for 20-MM Automatic Guns M24, M24A1, and M24E2—Continued

Standard nomenclature	Complete round		Projectile weight as fired (lb)	Action of fuze
	Weight (lb)	Length (in)		
FILLER AND LINK ¹				
FILLER, link 20-mm (A7305535) ⁴				
LINK, disintegrating belt, 20-mm, M10 (M8E1). ⁵				

AN —Army-Navy
 AP —armor-piercing
 API —armor-piercing incendiary
 AP-T—armor-piercing with tracer

HEI—high-explosive incendiary
 M —model
 TP —target-practice

¹ Length of a 20-round linked belt is 28½ inches.

² The projectile may be assembled without a tracer but with a plug in the tracer cavity or without a tracer and without a plug.

³ Length of trace is approximately 1,270 yards.

⁴ For double-loop LH feed with feed mechanisms M2E4 and M2E5.

⁵ For use with feed mechanisms AN-M2, M2E4, and M2E5.

these automatic guns are also ready for firing upon removal from packing materials but must be loaded into link belts as described in paragraphs 19 and 20. Cartridges prepared for firing but not fired will be returned to their original condition and packings or will be packed, as belted, in suitable packing boxes. The packing boxes should be appropriately marked to indicate the nomenclature of the cartridges, the quantity of cartridges therein, and the appropriate ammunition lot number. Such rounds will be used first in subsequent firings in order that stocks of opened packings may be kept at a minimum.

136. Fuzes

a. General. A fuze is a device used with a projectile to explode it at the time and under the circumstances required. The fuzes used with ammunition for this gun are assembled to the rounds as issued.

Caution: Fuzes will not be disassembled. Any attempt to disassemble fuzes in the field is dangerous and is prohibited except under specific directions from the Chief of Ordnance.

b. Classification. Fuzes are classified according to their manner of functioning as “time and impact,” “time,” or “impact.” Impact fuzes function upon striking a resistant object. They are classified, according to the time of functioning after impact, as *superquick*, *nondelay*, or *delay*. An impact fuze, which is intended to function on

RESTRICTED—Security Information

impact with a very light material target such as an aircraft wing, is called *supersensitive*.

c. Boresafety. In certain types of fuzes, the mechanisms are so arranged that the fuzes are said to be "boresafe" (detonator-safe). A bore-safe (detonator-safe) fuze is one in which the explosive train is so interrupted that, while the projectile is still in the bore of the weapon, premature action of the bursting charge is prevented if any of the more sensitive elements (primer or detonator) function. The FUZE, PD, T196E4, is considered boresafe. The FUZE, PD, M75, used with 20-mm ammunition, although not considered boresafe, may be fired under the same conditions as bore-safe fuzes.

d. Fuze, PD, M75.

(1) *Description.* This fuze is a single-action superquick type intended to penetrate light armor and to function with percussion action on impact with the heavier armor of aircraft. Its design differs from that of the ordinary fuze in that functioning is initiated on impact by the set-forward force of the detonator charge, by pieces of metal from the body striking the detonator charge, or by compression of the air column (with the accompanying formation of heat) forward of the detonator charge, or by a combination of any or all of these. Hence, the striker or firing pin mechanism usually found in point detonating fuzes is omitted in the fuze M75.

(2) *Setting.* This fuze requires no setting or other preparation for firing.

e. Fuze, PD, T196E4.

(1) *Description.* This fuze is a single-action impact type that functions with superquick action on impact with the target. The fuze mechanism incorporates a spherical rotor-type interrupter and a rotor safety spring. The safety spring provides boresafety by preventing the rotor from turning and prevents the firing pin from coming into contact with the rotor.

(2) *Setting.* This fuze requires no setting.

137. Precautions in Firing

Caution: The precautions given in *a* and *b* below should be closely observed in order to prevent injury to personnel or damage to matériel.

a. Before loading into the links, the ammunition should be free of foreign matter, such as sand, mud, moisture, frost, snow, ice, or grease. This does not apply to the wax coating on the cartridge case (par. 132*f*) that is required for proper functioning of the weapon. The loaded

RESTRICTED—Security Information

links should be likewise free of foreign matter before feeding into the weapon.

b. Misfires will be handled as indicated in paragraph 61 and SR 385-310-1.

138. Packing and Marking

a. General.

(1) Service, target-practice, and drill ammunition for the 20-mm automatic guns M24, M24A1, and M24E2 are packed as indicated in *b* and *c* below. Links and fillers are packed as indicated in *d* and *e* below. The data given are considered suitable for estimating weight and volume requirements.

(2) Complete data are published in Department of the Army Supply Catalogs ORD 3 SNL's R-1 and R-6.

b. Cartridges Packed in Cartons.

	Weight (lb)	Vol- ume (cu ft)
120 rounds (10 rounds in each of 12 paper cartons) in metal-lined box:		
HEI, M97; Drill, M18A2.....	96.0	1.47
Overall dimensions of 120-round packing box (in.): 18½ x 13¾ x 10¾		
150 rounds (25 rounds in each of 6 metal containers) in wooden packing box:		
AP-T, M95; HEI, M97; TP, M99; Drill, M18A3; Drill, M18A2.....	106.	1.39
Incendiary, M96.....	103.	1.39
Overall dimensions of 150-round packing box (in.): 17½ x 13¼ x 10¾		
225 rounds (25 rounds in each of 9 metal containers):		
HEI, M97; TP, M99.....	161.	1.50
Overall dimensions of 225-round packing box (in.): 18½ x 14¾ x 9½		

c. Cartridges Packed in Links.

80 rounds (40 rounds per metallic link belt in metal can M21, 2 cans) per wooden box M23:

AP, M95; API, T21E1; AP-T, M95A1; HEI, M97; Incendiary, M96; TP, M99.....	72.0	1.28
Overall dimensions of 80-round packing box (in.): 15½ x 13¼ x 11¼		

RESTRICTED—Security Information

	Weight (lb)	Vol- ume (cu ft)
<i>d. LINK, Disintegrating Belt, M10 (M8E1).</i>		
500 links (10 links in each of 50 paper cartons) in a fiber container, in a wooden box:		
Overall dimensions of 500 link packing box (in.): 18¼ x 12¼ x 12¾-----	53.0	1.72
500 links in paper-lined wooden box:		
Overall dimensions of 500 link packing box (in.): 18½ x 11 x 8½-----	35.3	1.00
<i>e. FILLER, Link.</i>		
5,400 fillers in wooden box:		
Overall dimensions of 5,400 filler packing box (in.): 12 x 18 x 10-----	66.0	1.24

CHAPTER 6

SHIPMENT AND LIMITED STORAGE AND DESTRUCTION OF MATERIEL TO PREVENT ENEMY USE

Section I. SHIPMENT AND LIMITED STORAGE

139. Domestic Shipping Instructions

a. Preparation for Shipment in Zone of Interior. When shipping 20-mm automatic gun M24, M24A1, or M24E2 interstate or within the zone of interior, the officer in charge of preparing the shipment *will be responsible* for furnishing weapons to the carriers for transport in a *serviceable* condition, properly cleaned, preserved, packaged, and packed (pars. 141 and 142).

b. Preparation for Shipment to Ports.

(1) *Inspection.* All used weapons destined for oversea use will be inspected prior to shipment in accordance with TB ORD 385.

(2) *Preparation for Shipment to Ports.* Prepare all weapons destined to ports of embarkation for oversea shipment in the same manner as prescribed for domestic shipment. In addition, boxes will be marked for oversea shipment as prescribed in paragraph 141f(2).

c. Army Shipping Documents. Prepare all Army shipping documents accompanying freight in accordance with TM 38-705.

140. Limited Storage Instructions

a. Receiving Inspections.

(1) Report all weapons received for storage in a damaged condition or improperly prepared for shipment on DD Form 6, in accordance with SR 745-45-5. Report of weapons received in an unsatisfactory condition (chronic failure or malfunction of the weapon or equipment) will be reported on AF Form 54, Unsatisfactory Report, in accordance with SR 700-45-5.

(2) Immediately upon receipt, weapons that have not already been inspected and prepared for limited storage must be given a limited technical inspection and processed, packaged, and packed as prescribed in paragraphs 141 and 142. The results

RESTRICTED—Security Information

and classification of weapons will be recorded and packed with the unit.

- (3) Perform a systematic inspection and replace or repair all missing or broken parts. If repairs are beyond the scope of the unit, causing weapons to be out of service for an appreciable length of time, store the weapons in a limited storage status and attach a tag to them specifying repairs needed. Reports of these conditions will be submitted by the unit commander for action by an ordnance maintenance unit.

b. Inspection During Storage. Perform a visual inspection periodically to determine general condition, as prescribed below. If corrosion is found on any part, remove rust spots, clean, and treat with the prescribed preservatives.

Note. Aircraft guns that are packed with volatile corrosion inhibitor (VCI) must not be removed from pack for percentage inspection. However, box end should be removed and contents slid out and an inspection made of the contents. If pack is damaged or broken, weapon will be removed and processed, packaged, and packed as prescribed in paragraphs 141 and 142.

- (1) Inspection of a percentage of stock on hand will be performed by qualified personnel as prescribed in SR 743-110-1.
- (2) Inspectors must carefully examine selected weapons for packaging, observing condition of containers, legibility and accuracy of package markings, and method of packaging.

c. Storage Site.

- (1) Personnel must carefully note the storage location to determine whether it is adequate for weapons involved.
- (2) Store all 20-mm automatic guns M24, M24A1, and M24E2 in a humidity-controlled room where the moisture content of the air is kept to a low relative humidity and at an even temperature, whenever possible. Where it is found necessary to store weapons outdoors, cover and protect them against the elements as prescribed in TB ORD 379.

d. Removal From Limited Storage.

- (1) If the weapons are not shipped or issued upon expiration of the 90-day limited storage period, they must be further inspected as prescribed in *b* above.
- (2) If the weapons to be shipped will reach their destination within the scope of the limited storage period, they need not be processed upon removal from storage unless inspection reveals it to be necessary according to anticipated in-transit weather conditions.

Note. All weapons being reissued through the depot supply system to troops within the continental limits of the United States must meet the requirements of TB ORD 385. This is NOT required for so-called

RESTRICTED—Security Information

reissues, exchanges, or redistribution among troop units, where the depot supply system is not involved.

- (3) Service weapons in accordance with paragraphs 8 through 12, when it has been ascertained that they are to be placed into immediate service. Lubricate as prescribed in paragraphs 38 through 43.
- (4) Repair and/or replace all weapons tagged in accordance with *a*(3) above.

141. Processing, Packaging, and Packing Instructions

a. Disassembly. Prior to cleaning and preserving guns, remove the contact assembly from the receiver of the gun and package as described in *d* below.

Note. Do not apply corrosion preventive to the contact assembly.

b. Cleaning.

Note. It is of utmost importance that all parts be spotlessly cleaned prior to application of preservatives. During cleaning of items, it is imperative that cloth or synthetic rubber gloves be worn while handling items.

- (1) All metallic parts of the gun will be cleaned by scrubbing with cloths soaked in dry-cleaning solvent or volatile mineral spirits, followed by wiping with clean solvent-soaked cloths. When the solvent-soaked cloths become too dirty for further use, discard them and use clean solvent-soaked cloths. Clean cloths must be used for the final wiping operation. Dry all parts thoroughly (TM 38-230).
- (2) All nonmetallic parts and assemblies containing nonmetallic parts will be wiped with a clean dry cloth.
- (3) Remove contact assembly from the receiver. This assembly must not be treated with corrosion preventive.

c. Preservation.

- (1) Submerge the entire gun at a 45-degree angle (muzzle end down) in a bath of preservative lubricating oil (special MIL-L-G44). Gun must remain submerged in bath for 15 to 30 seconds to insure that the preservative reaches all recesses and concealed parts.
- (2) Remove gun and allow all excess preservative to drain by gravity for a sufficient period of time before packaging or packing is undertaken. Care must be exercised in handling the preserved gun in order to avoid possible removal of the preservative.

d. Packaging.

- (1) *Contact assembly.* The contact assembly will be wrapped

RESTRICTED—Security Information

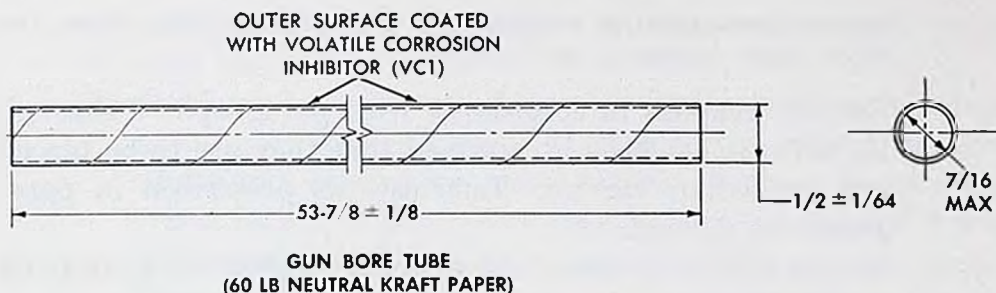

NOTE: ALL DIMENSIONS SHOWN ARE IN INCHES

RA PD 171479

Figure 165. Volatile corrosion inhibitor (VCI) bore tube for 20-mm automatic gun M24, M24A1, or M24E2.

in grease-proof barrier-material, type I or II, grade C, class 1 or 2 and inserted in a bag made of flexible water-vapor-proof barrier-material. The bag will be taped to the shipping bag near the muzzle end of the gun as prescribed in (2) (f) below.

(2) *Volatile corrosion inhibitor (VCI) package.*

- (a) Remove the neutral kraft paper from the bore tube and insert the volatile corrosion inhibitor bore tube (fig. 165) into the bore of the gun. Fold over the portion of the tube (aprx. 2 inches) protruding from the bore.

Note. Bore tubes must be kept inclosed in neutral kraft paper until ready for use, to avoid dissipating the preservative.

- (b) Insert the gun into the shipping bag (fig. 166). Aline the holes in the bag with the holes in the cradle of the gun.
- (c) Position the plywood slide (figs. 166 and 167) over the holes in the shipping bag. Line up holes in slide and bag with holes in cradle of gun. Attach plywood slide to gun with eight $\frac{3}{8}$ x 16NC x $1\frac{1}{4}$ bolts and washers.

Note. In nailing rubbing strips to slide base, do not nail within 1 inch of the outside edge of the slide. Nail heads or points must not protrude.

- (d) Wrap water-resistant pressure-sensitive adhesive tape, type I, grade B, tightly around the shipping bag, $1\frac{1}{2}$ feet and 3 feet from the muzzle end of the gun. Conform the rest of the bag to the gun.
- (e) Fold the bag liner as far into the body of the bag as possible. Force all excess air out with a vacuum pump, if available, prior to final closure. Apply at least a $\frac{3}{4}$ -inch heat seal to the open end of the bag. If any oil is on the heat seal surface, it must be thoroughly removed before sealing. Fold over the sealed end of the bag.

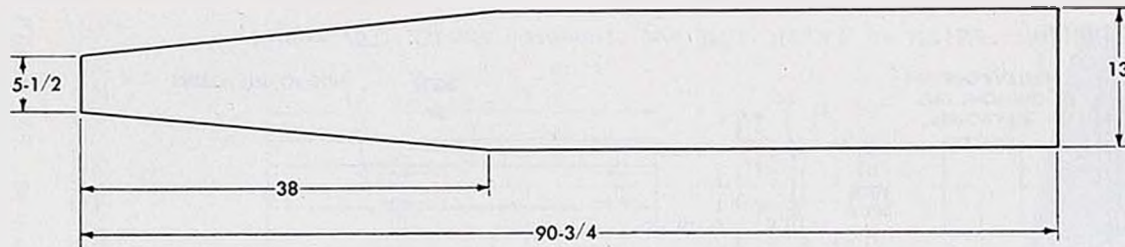

BODY
(SEE NOTE 1)

NOTES:

- 1—THE BODY IS MADE FROM FLEXIBLE WATER-VAPORPROOF BARRIER-MATERIAL, CLASS A—TWO REQUIRED.
- 2—THE LINER IS MADE FROM CREPED HEAVY DUTY VOLATILE CORROSION INHIBITOR(VCI) MATERIAL—TWO REQUIRED
- 3—X INDICATES WHERE LINER IS TO BE "TACKED" TO BODY ON PERFORATED SIDE ONLY WITH WATER RESISTANT ADHESIVE.
- 4—ALL DIMENSIONS ARE SHOWN IN INCHES.

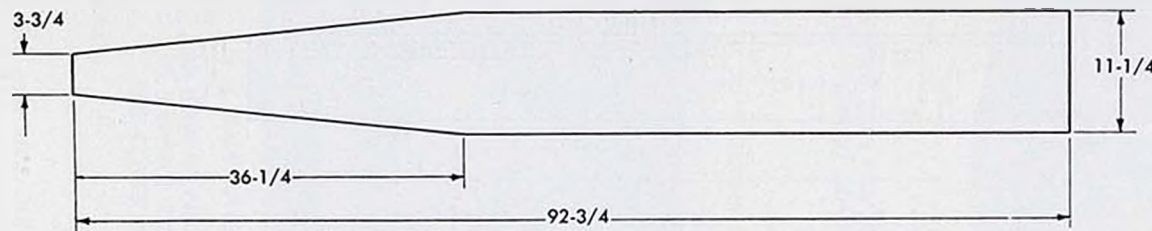

LINER (SEE NOTE 2)

3/4 WIDE HEAT SEALED EXCEPT AT LARGE END

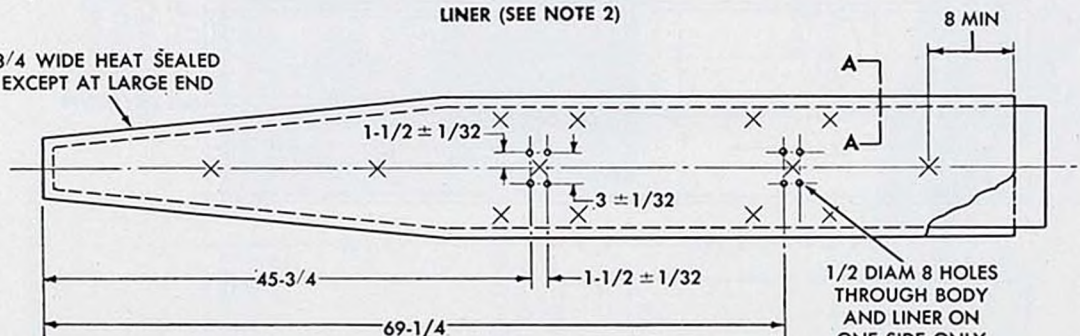

1/2 DIAM 8 HOLES THROUGH BODY AND LINER ON ONE SIDE ONLY

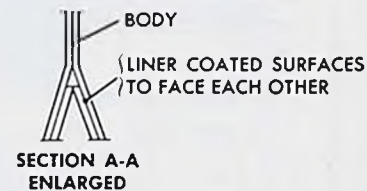

SECTION A-A ENLARGED

ASSEMBLY
(SEE NOTE 3)

RA PD 171415

Figure 166. Volatile corrosion inhibitor (VCI) shipping bag for 20-mm automatic gun M24, M24A1, or M24E2.

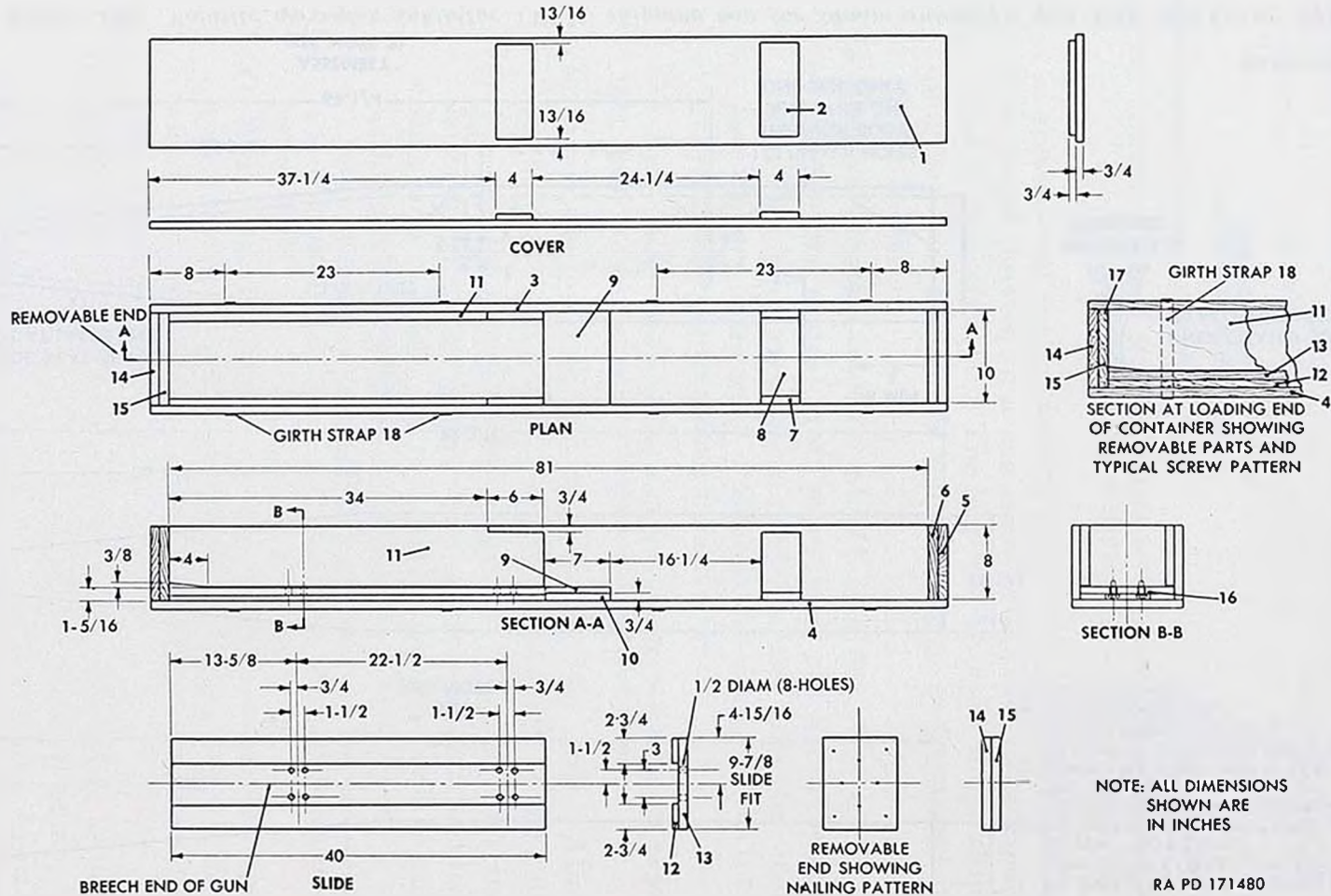
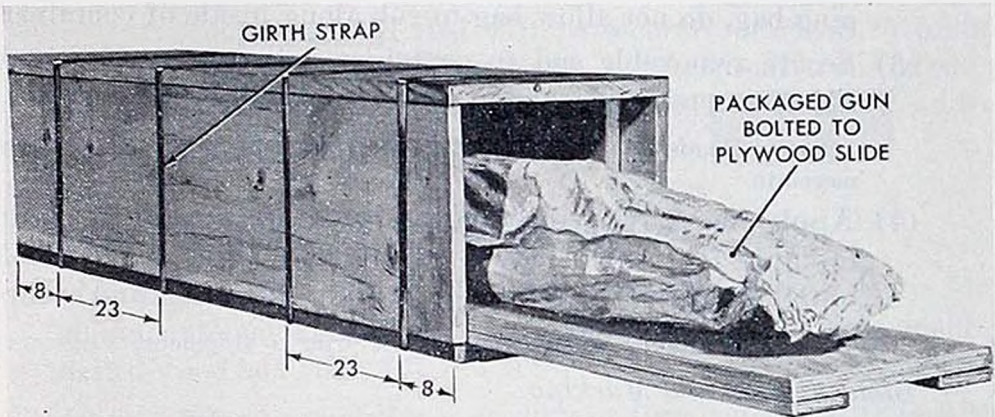

Figure 167. 20-mm automatic gun M24, M24A1, or M24E2—shipping container details.

RESTRICTED—Security Information

Note. Extreme care must be taken during the packaging and packing process, to avoid damaging the water-vaporproof shipping bag. If the body of the bag is punctured or torn or if the heat seal is unsealed anywhere around the perimeter of the bag, the bag must be replaced.

- (f) After the gun has been packaged and secured to plywood base, the packaged contact assembly will be taped to the



PACKAGED GUN PARTIALLY SLID INTO SHIPPING CONTAINER

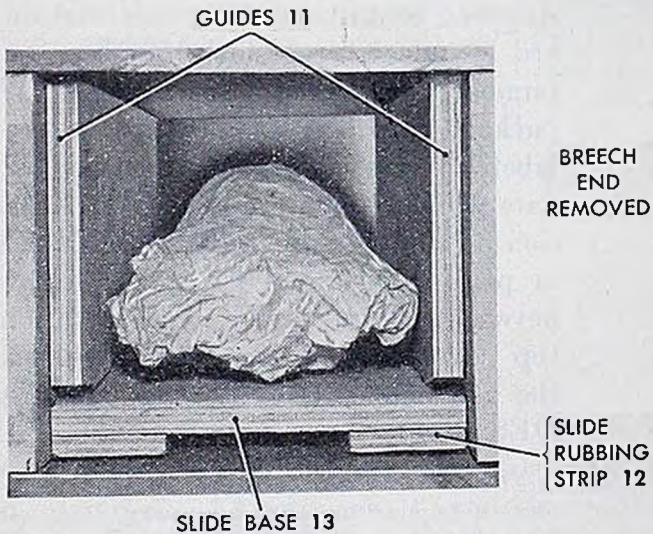

END VIEW OF PACKAGED GUN IN SHIPPING CONTAINER—END COVER REMOVED

NOTE: ALL DIMENSIONS SHOWN ARE IN INCHES

RA PD 171481

Figure 168. 20-mm automatic gun M24, M24A1, or M24E2—side and end view of pack.

RESTRICTED—Security Information

shipping bag near the muzzle end of the gun with water-resistant pressure-sensitive adhesive tape, type I, grade B.

e. Packing.

- (1) Construct a double-end nailed wood box as prescribed in paragraph 142.
- (2) Slide the packaged gun (muzzle end first) into the open end of the container. To avoid possibility of ripping the shipping bag, do not allow bag to rub along inside of container.
- (3) Secure removable end to container with twenty No. 10 x 1¾ long screws, five at top, sides and bottom (167).

Note. Heads of screws must not protrude and must not be hammered in.

- (4) Apply four girth straps around container, spaced as shown in figure 168. All straps must be drawn tight so as to sink into the edges of the container. Apply strap seals and crimp.

Note. Strapping will be applied just prior to shipment.

f. Identification and Marking.

(1) *Domestic.*

- (a) After unit has been packed, the standard marking information required to identify and mark containers for domestic shipment will be printed or stenciled directly onto shipping container. This information will include standard nomenclature, stock number, or other identifying number; quantity and size; weight (WT); cubage (CU); package number (where required); domestic address label; caution labels and markings (where required); and date packed (month and year). Adjacent to the description of contents, the letters "DOM PK" will be stenciled or printed in letters 1½ inches high where possible, but never less than 1 inch. In addition, the underside of top cover will be stenciled in letters 1 inch high with the notation "REUSABLE CONTAINER—DO NOT DESTROY."

Note. When set markings, packing lists, and special and technical data markings are necessary, they will be used and applied in accordance with specific instructions from the officer in charge.

- (b) Do not apply labels or mark containers unless contents have been actually inspected and processed.

(2) *Overseas.*

- (a) When destined to ports of embarkation for oversea shipment, the container will be labeled or stenciled as prescribed for domestic shipment in (1) above and, in addition, will

RESTRICTED—Security Information

include the oversea address and service color marking (SR 746-30-5).

- (b) Each container shipped to a port in less than a carload lot (LCL) or less than truckload lot (LTL) will also bear a domestic address; old addresses and irrelevant data will be effectively removed or obliterated prior to shipment. A label not exceeding 28 inches in length (yellow corners not required on label) will be used for domestic addresses. Label will be securely attached to container and will be covered with a waterproof transparent protective-coating cement. Stenciling of domestic addresses on containers is not permitted.

142. Construction of Shipping Container

a. Shipping Box Data. The data contained in table IX is for one 20-mm automatic gun M24, M24A1, or M24E2, packed in a double-end nailed wood box (figs. 167 and 168).

Note. Before constructing a quantity of these boxes, a trial pack should be made and the dimensions of the container or blocking adjusted, if necessary.

Table IX. Shipping Box Data

Shipping data	Box dimension (in.)		Volume and weight
	Inside	Outside	
Length.....	81	85¼	-----
Width.....	10	11½	-----
Height.....	8	9½	-----
Area (sq ft).....			6.8
Volume (cu ft).....			5.4
Bearing pressure (lb per sq ft).....			17
Ship tons (40 cu ft).....			.13
Shipping weight (gross lb approx.).....			120

b. Bill of Materials. Table X lists the materials required to construct a double-end nailed wood box (figs. 167 and 168) for one 20-mm automatic gun M24, M24A1, or M24E2. The box is designed to be constructed from group I or II lumber of standard thickness. All the plywood used for interior blocking and the slide base is constructed from groups I or II, type A, condition I lumber. The reference numbers are those referred to in the text and figures 167 and 168.

RESTRICTED—Security Information

Table X. Bill of Materials

Reference No.	Quantity required	Part name	Actual size—inches		
			Length	Width	Thickness
		<i>SHIPPING CONTAINER</i> (figs. 167 and 168)			
1	1	Cover ¹	85¼	11½	¾
2	2	Cover cleat (plywood).....	9⅞	4	¾
3	2	Side ¹	85¼	8	¾
4	1	Bottom ¹	85¼	11½	¾
5	1	End (fixed outside) ¹	10	8	1⅛
6	1	End (fixed inside) ¹	10	8	1⅛
7	2	Side cleat (plywood).....	6½	4	¾
8	1	Bottom cleat (plywood).....	10	4	¾
9	1	Stop (plywood).....	10	7	½
10	1	Stop (plywood).....	10	7	¾
11	2	Guides (plywood).....	40	6⅝	¾
12	2	Rubbing strip (plywood).....	40	2¾	½
13	1	Slide base (plywood).....	40	9⅞	¾
14	1	End (removable outside) ¹	10	8	1⅛
15	1	End (removable inside) ¹	10	8	1⅛
16	² 8	Bolts—¾ x 16NC x 1¼ long with 1-inch diameter washers.			
17	20	Screws—No. 10 x 1¼ long.....			
18	² 4	Straps and Seals.....	42	1	0.035
	(3)	Nails.			
	(3)	Staples.			
		<i>PACKAGING MATERIALS</i>			
	(3)	Greaseproof barrier-material type I or II, grade C, class 1 or 2.			
	(3)	Flexible water-vaporproof barrier-material.			
	(3)	Volatile corrosion inhibitor (VCI).			
		Bore tube (fig. 165).			
	(3)	Water-resistant pressure-sensitive adhesive tape.			
		Preservative lubricating oil (special).			
		Dry-cleaning solvent.			
		Volatile mineral spirits.			

¹ The width of ends, sides, top, and bottom may be made of several pieces, but no piece must be less than 2½ inches in width.

² Each. ³ As required.

c. Fastening Schedule. Table XI lists the fastening schedule to be used when fabricating the box illustrated in figures 167 and 168. If prescribed size of nail or screw is not available, use the next smaller size and reduce spacing by one-quarter inch.

RESTRICTED—Security Information

Table XI. Fastening Schedule

Fasten		Nail size and type	Maxi- mum spacing (in.)	Notes
Part	To part			
GUN SLIDE (figs. 167 and 168)				
Rubbing strips (12).	Slide base (13)---	5d cem-ctd.	6-8	Staggered and clinched.
SHIPPING CONTAINER (figs. 167 and 168)				
End (5)-----	End (6)-----	8d cem-ctd.	2½	Stagger and clinch
End (14)-----	End (15)-----	do-----	2½	Do.
Cover (1)-----	Cover cleats (2)---	6d cem-ctd.	2	Do.
Sides (3)-----	Side cleats (7)---	do-----	2	Do.
Do-----	Guides (11)-----	do-----	2	Do.
Bottom (4)-----	Bottom cleat (8)---	do-----	2	Do.
Do-----	Stop (9)-----	5d cem-ctd.	2	Do.
Sides (3)-----	Ends (5) and (6)---	8d cem-ctd.	2½	Stagger.
Bottom (4)-----	do-----	do-----	2½	Do.
Do-----	Sides (3)-----	do-----	6-8	
Cover (1)-----	Ends (5) and (6)---	do-----	2½	Stagger.
Do-----	Sides-----	do-----	6-8	
Sides (3), Cover (1), and Bottom (4).	Removal end (14) and (15).	Screws-----		Five No. 10 x 1¾ long flathead wood screws per face.

143. Loading and Blocking Instructions

For general loading rules and for methods and procedures for loading and blocking boxed items in boxcars, refer to TM 9-2854.

Section II. DESTRUCTION OF MATERIEL TO PREVENT ENEMY USE

144. General

a. Destruction of the 20-mm automatic gun M24, M24A1, or M24E2, when subject to capture or abandonment in the combat zone, will be undertaken by the using arm only, when, in the judgment of the unit commander concerned, such action is necessary in accordance with orders of, or policy established by, the army commander. When these guns are in the possession of ordnance maintenance personnel, or in storage, destruction will be in accordance with FM 9-5 and applicable portions of the information below.

RESTRICTED—Security Information

b. The following information is for guidance only. Certain of the procedures outlined require the use of explosives and incendiary grenades that normally may not be authorized items for the airplane. The issue of these and related materials and the conditions under which destruction will be affected are command decisions in each case according to the tactical situation. Of the several means of destruction, those most generally applicable are—

Mechanical-----	Requires axe, pick mattock, sledge, crowbar, or similar implement.
Burning-----	Requires gasoline, oil, incendiary grenades, or other inflammables.
Demolition-----	Requires suitable explosives or ammunition.
Gunfire-----	Includes artillery, machine guns, rifles using rifle grenades, and launchers using antitank rockets. Under some circumstances, hand grenades may be used.

In general, destruction of essential parts by mechanical means will usually be sufficient to render the gun useless. However, selection of the particular method of destruction requires imagination and resourcefulness in the utilization of the facilities at hand, under the existing conditions. Time is usually critical.

c. If destruction to prevent enemy use is resorted to, the gun must be so badly damaged that it cannot be restored to a usable condition in the combat zone, either by repair or cannibalization. Adequate destruction requires that all parts essential to the operation of the gun, including essential spare parts, be destroyed or damaged beyond repair. However, when lack of time or personnel prevents destruction of all parts, priority is given to the destruction of those parts most difficult to replace. Equally important, the same essential parts must be destroyed on all like materiel, so that the enemy cannot construct one complete unit from several damaged ones.

d. If destruction is directed, due consideration should be given to—

- (1) Selection of a point of destruction that will cause greatest obstruction to enemy movement and will also prevent hazard to friendly troops from fragments or ricocheting projectiles that may occur incidental to destruction.
- (2) Observance of appropriate safety precautions.

145. Destruction of the 20-MM Automatic Gun M24, M24A1, or M24E2

a. *General.* If time, personnel, and materials are available, the destruction of the armament should be accomplished in conjunction

RESTRICTED—Security Information

with the destruction of the airplane by incendiary means. However, if it is inadvisable to destroy the airplane by fire, or if the armament is to be destroyed separately from the airplane, the armament should be destroyed by one of the methods outlined below.

b. Method No. 1—by Smashing. Using an axe, pick mattock, sledge, or other heavy implement, smash the feed mechanism, breech-block contact, charger, gas cylinder, and receiver. Elapsed time: about 2 minutes.

c. Method No. 2—With Demolition Materials.

- (1) Remove the feed mechanism from the gun.
- (2) Prepare a 1-pound charge of EXPLOSIVE, TNT (using a 1-lb block or equivalent, together with the necessary detonating cord), and place the charge in the magazine slide opening.
- (3) For priming, either a nonelectric blasting cap crimped to at least 5 feet of safety fuse (safety fuse burns at the rate of 1 foot in 30 to 45 seconds;—test before using), or an electric blasting cap and firing wire may be used. Safety fuse, which contains black powder, and blasting caps must be protected from moisture at all times. If an electric blasting cap and firing wire are used, the gun must be disconnected from all sources of electrical energy before placing the charge. The safety fuse may be ignited by a fuse lighter or a match; the electric blasting cap requires a blasting machine or equivalent source of electricity.

Caution: Keep the blasting caps, detonating cord, and safety fuse separated from the charges until required for use.

Note. For the successful execution of methods of destruction involving the use of demolition materials, all personnel concerned will be thoroughly familiar with the provisions of FM 5-25. Training and careful planning are essential.

- (4) Detonate the charge. If primed with nonelectric blasting cap and safety fuse, ignite and take cover. If primed with electric blasting cap, take cover before firing the charge. Elapsed time: about 3 minutes.

d. Method No. 3—With HEI Ammunition.

- (1) Plug the bore, for approximately two-thirds of its length, using a cleaning staff wrapped with cloth or waste to make a tight fit. In lieu of a cleaning staff, stones, mud, or similar material may be used to plug the bore.
- (2) Load the gun with an HEI cartridge and fire from cover, using a lanyard about 100 feet long. The danger zone is approximately 100 yards. Elapsed time: about 3 minutes.

APPENDIX

REFERENCES

1. Publication Indexes

The following publication indexes and lists of current issue should be consulted frequently for latest changes or revisions of references given in this appendix and for new publications relating to materiel covered in this manual:

Index to Administrative Publications.....	SR 310-20-5
Index of Army Motion Pictures, Kinescope Recordings, and Film Strips.	SR 110-1-1
Index of Blank Forms and Army Personnel Classification Tests.	SR 310-20-6
Index to Tables of Organization and Equipment, Reduction Tables, Tables of Organization, Tables of Equipment, and Tables of Allowances.	SR 310-20-7
Index of Technical Manuals, Technical Regulations, Technical Bulletins, Supply Bulletins, Lubrication Orders, and Modification Work Orders.	SR 310-20-4
Index of Training Publications.....	SR 310-20-3
Introduction and Index (supply catalogs)--	ORD 1
Military Training Aids.....	FM 21-8

2. Supply Catalogs

The following catalogs of the Department of the Army Supply Catalog pertain to this materiel:

a. Ammunition.

Ammunition, Fixed and Semifixed, Including Subcaliber, for Pack, Light and Medium Field, Aircraft, Tank, and Antitank Artillery, Including Complete Round Data.	ORD 3 SNL R-1
Ammunition Instruction Material for Pack, Light and Medium Field, Aircraft, Tank, and Antitank Artillery.	ORD 3 SNL R-6

RESTRICTED—Security Information

<i>b. Armament.</i>	
Gun, Automatic, 20-mm, M24 and M24A1-----	ORD (*) SNL A-73
<i>c. Destruction to Prevent Enemy Use.</i>	
Land Mines and Components; Demolition Explosives and Related Items; and Ammunition for Simulated Artillery, Booby Trap, Hand Grenade, and Land Mine Fire.	ORD 3 SNL R-7
<i>d. Maintenance and Repair.</i>	
Cleaners, Preservatives, Lubricants, Recoil Fluids, Special Oils, and Related Maintenance Materials.	ORD 3 SNL K-1
Shop Set, Small Arms, Field Maintenance----	ORD 6 SNL J-8, Section 6
Special Tool Sets for Small Arms and Automatic Weapons (SNL Groups A and B).	ORD 6 SNL J-12
Tool Set, Armorers-----	ORD 6 SNL J-10, Section 1

3. Forms

The following forms are applicable to this materiel:

AF Form 54, Unsatisfactory Report.

AF Form 185, Maintenance and Performance Record.

DD Form 6, Report of Damaged or Improper Shipment.

4. Other Publications

The following explanatory publications contain information pertinent to this materiel and associated equipment:

a. Ammunition.

Ammunition, General-----	TM 9-1900
Ammunition Inspection Guide-----	TM 9-1904
Artillery Ammunition-----	TM 9-1901
Ballistic Data, Performance of Ammunition--	TM 9-1907
Qualifications in Arms and Ammunition Training Allowances.	AR 775-10
Regulations for Firing Ammunition for Training, Target Practice, and Combat.	SR 385-310-1
Small-Arms Ammunition-----	TM 9-1990

b. Camouflage.

Camouflage, Basic Principles-----	FM 5-20
-----------------------------------	---------

c. Decontamination.

Decontamination -----	TM 3-220
Defense Against Chemical Attack-----	FM 21-40

(*) See ORD 1 for published catalogs of the ordnance section of the Department of the Army Supply Catalog.

RESTRICTED—Security Information

d. Destruction to Prevent Enemy Use.

Explosives and Demolitions.....	FM 5-25
Ordnance Service in the Field.....	FM 9-5

e. General.

Safety: Report of Accident Experience.....	SR 385-10-40
Supplies and Equipment: Unsatisfactory Equipment Report.	SR 700-45-5

f. Shipment and Limited Storage.

Army Shipping Document.....	TM 38-705
Catalog of Approved Packaging Instructions for Major Items and Spare Parts for Ord- nance General Supplies.	PS-1000 ¹
Instruction Guide: Ordnance Packing and and Shipping (Posts, Camps, and Sta- tions).	TM 9-2854
Long Term Storage, Maintenance and Care and Preservation and Storage of Small Arms Materiel.	SR 743-110-1
Marking and Packing of Supplies and Equip- ment: Marking of Oversea Supply.	SR 746-30-5
Military Standard—Marking of Shipments..	MIL-STD-129 ²
Ordnance Storage and Shipment Chart— Group A.	TB 9-OSSC-A
Preservation, Packaging, and Packing of Military Supplies and Equipment.	TM 38-230
Protection of Ordnance General Supplies in Open Storage.	TB ORD 379
Shipment of Supplies and Equipment: Re- port of Damaged or Improper Shipment.	SR 745-45-5
Standards for Oversea Shipment and Do- mestic Issue of Ordnance Materiel Other Than Ammunition and Army Aircraft.	TB ORD 385

¹ Copies may be obtained from the Raritan Arsenal Publications Division, Metuchen, N. J.

² Copies may be obtained from Aberdeen Proving Ground, Md.

RESTRICTED—Security Information

INDEX

	<i>Para-</i> <i>graphs</i>	<i>Page</i>
Accidents, field report.....	2a	6
Adjusting gun for left- or right-hand feed.....	21	38
Allocation maintenance:		
Field.....	91	127
Organizational.....	44	64
Ammunition:		
Authorized rounds:		
Components.....	134	201
Data (table VIII).....	134	201
Description.....	134	201
Standard nomenclature.....	134	201
Care, handling, and preservation.....	133	200
Classification.....	131	196
Data (packing and marking).....	138	205
Firing tables.....	130	196
Fuzes:		
Boresafety.....	136	203
Classification.....	136	203
Setting.....	136	203
Identification:		
Lot number.....	132	198
Marking.....	132	198
Model.....	132	198
Painting.....	132	198
Packing and marking.....	138	205
Precautions in firing.....	137	204
Preparation for firing.....	135	201
Wax coating.....	132	198
Ammunition linking machine:		
Adjustment.....	20a	35
Loading belts into.....	20	35
Packing data (links and belts).....	138	205
Barrel assembly, differences among models.....	4b	7
Belts, loading:		
By hand:		
Left-hand feed.....	19c, d	34, 35
Right-hand feed.....	19b	33
By machine:		
Left-hand feed.....	20c, d	37, 38
Right-hand feed.....	20b	37
Bore:		
Cleaning bore and chamber.....	46b	65
Data.....	6	20

RESTRICTED—Security Information

	<i>Para- graphs</i>	<i>Page</i>
Breechlock contact assembly:		
Organizational maintenance.....	81	112
Packaging.....	141d	209
Breechblock group:		
Assembly:		
Field maintenance.....	105	144
Organizational maintenance.....	73	103
Cyclic functioning.....	50, 54, 69	70, 75, 99
Disassembly:		
Field maintenance.....	103	141
Organizational maintenance.....	71	100
Installation (organizational maintenance).....	74	104
Maintenance:		
Field.....	104	143
Organizational.....	72	100
Removal (organizational maintenance).....	70	99
Buffer, rear. (<i>See</i> Rear buffer assembly <i>and</i> Rear buffer spring.)		
Chargers:		
Adjusting for right- or left-hand charging (organizational maintenance):		
Manual charger M6.....	18a	27
Pneumatic charger M4.....	18b	30
Assembly (field maintenance):		
Manual charger M6.....	120	165
Pneumatic charger M4.....	123	169
Charging the gun (organizational maintenance):		
With manual charger M6.....	25b	49
With pneumatic charger M4.....	25a	49
Data.....	7	20
Description:		
Manual charger M6.....	84	124
Pneumatic charger M4.....	86	124
Disassembly (field maintenance):		
Manual charger M6.....	118	161
Pneumatic charger M4.....	121	167
Field maintenance:		
Manual charger M6.....	120	165
Pneumatic charger M4.....	123	169
Functioning:		
Manual charger M6.....	56a	78
Pneumatic charger M4.....	56b	78
Mounting and dismounting (organizational maintenance):		
Manual charger M6.....	18a	27
Pneumatic charger M4.....	18b	30
Operation.....	25	49
Organizational maintenance:		
Manual charger M6.....	85	124
Pneumatic charger M4.....	87	124
Charging the gun.....	25	49
Cleaning:		
Bore and chamber.....	46b(1)	65
For shipment or storage.....	141	209

RESTRICTED—Security Information

	<i>Para- graphs</i>	<i>Page</i>
Cleaning—Continued		
Guns and equipment coated with rust-preventive compound	12	23
Prior to lubrication	39	63
Cradle group:		
Adjustment (field maintenance)	102	140
Assembly and installation (field maintenance)	101	139
Maintenance:		
Field	100	139
Organizational	64	93
Removal and disassembly (field maintenance)	99	137
Cyclic functioning of weapon:		
Breechblock locking action	54	75
Breechblock unlocking action	50	70
Extraction and ejection	53	73
Feeding and chambering	52	73
Firing action	55	77
General	48	67
Rear buffer and driving spring action	51	72
Recoil action	49	69
Cyclic rate of fire (gun)	3	7
Data:		
Ammunition:		
Authorized rounds (table VIII)	134	201
Packing and marking	138	205
Equipment	7	20
Guns	6	20
Destruction of materiel to prevent enemy use:		
Destruction:		
Ammunition (HEI)	145	218
Gun	145	218
General instruction	144	217
Differences among:		
Feed mechanisms	4c	14
Guns	4b	7
Driving spring guide group (organizational maintenance):		
Assembly and installation	68	98
Maintenance	67	96
Removal and disassembly	66	95
Electrical firing circuit, checking	17	26
Equipment. (See Tools and equipment.)		
Feed chute and cover, installation	23	44
Feed mechanisms:		
Adjusting gun for left- or right-hand feed	21	38
Assembly (field maintenance):		
AN-M2	127	187
M2E4 and M2E5	128	193
Cyclic functioning	52	73
Data	7	20
Description	88	124
Differences among models	4c	14

RESTRICTED—Security Information

Feed mechanisms—Continued

	<i>Para-</i> <i>graphs</i>	<i>Page</i>
Disassembly (field maintenance):		
AN-M2	124	170
M2E4 and M2E5	125	179
Functioning	57	81
Installation	22	43
Loading	24	47
Loading of belts:		
By hand:		
Left-hand feed	19c, d	34, 35
Right-hand feed	19b	33
By machine:		
Left-hand feed	20c, d	37, 38
Right-hand feed	20b	37
Maintenance:		
Field	126	187
Organizational	88, 89	124, 126
Removal	27	50
Unloading	27	50
Firing ammunition:		
Precautions in	137	204
Preparation for	135	201
Firing circuit, electrical. (See Electrical firing circuit.)		
Firing tables	130	196
Firing the gun:		
Care before and after firing	46	65
Rate of fire	6	20
To fire and cease firing	26	50
Functioning. (See Cyclic functioning.)		
Gas cylinder group:		
Adjustment, guns M24 and M24E2	109	145
Assembly:		
Field maintenance:		
Gun M24A1	112	147
Guns M24 and M24E2	108	145
Organizational maintenance	78	109
Disassembly:		
Field maintenance:		
Gun M24A1	110	146
Guns M24 and M24E2	106	145
Organizational maintenance	76	108
Maintenance:		
Field:		
Gun M24A1	111	146
Guns M24 and M24E2	107	145
Organizational	75, 77	107, 109
Gun tube:		
General	80a	109
Installation	116	159
Maintenance:		
Field	115	155
Organizational	80c	111

RESTRICTED—Security Information

	<i>Para- graphs</i>	<i>Page</i>
Gun tube—Continued		
Removal from receiver.....	114	148
Threads for British mounts.....	80a	109
Identification information:		
Ammunition.....	132	198
Guns.....	5	14
Inspections:		
Field maintenance trouble shooting (table VII).....	98	133
Inspection guide for 20-mm guns (table VI).....	98	133
In field maintenance shops.....	98c	135
In hands of using organizations.....	98b	133
Overall.....	98	133
Postflight test-fired weapons in aircraft.....	46b	65
Preflight:		
Weapons in aircraft.....	46a	65
Weapons in shop.....	46c	66
Installation of gun in aircraft.....	14	23
Limited storage instructions.....	140	207
Linking machine. (See Ammunition linking machine.)		
Links, ammunition, packing data.....	138	205
Lock clearance:		
Adjustment.....	117	161
Checking:		
Gun M24A1.....	16	25
Guns M24 and M24E2.....	15	23
Lubrication:		
General instructions.....	39	63
In extreme-cold weather.....	40	63
In extreme-hot weather.....	41	63
Lubrication chart.....	38	62
Storage, handling and use of lubricants in extreme cold.....	29	50
Under:		
Moist or salt atmospheric conditions.....	43	64
Sandy and dusty conditions.....	42	63
Magazine slide:		
Adjustment.....	21b	38
Assembly and installation.....	82d	123
Maintenance.....	82c	121
Removal and disassembly.....	82b	121
Maintenance:		
Allocation:		
Field.....	91	127
Organizational.....	44	64
General instructions:		
Field.....	90	127
Organizational.....	45	64
Under unusual conditions.....	38-43	62-64
(See also Lubrication, Preventive maintenance, and under specific items.)		
Mechanisms, feed. (See Feed mechanisms.)		
Misfire. (See Trouble shooting.)		

RESTRICTED—Security Information

	<i>Para- graphs</i>	<i>Page</i>
Operation under unusual conditions.....	28-33	50-53
Operation under usual conditions.....	13-27	23-50
Packing instructions.....	141	209
Parts (spare):		
Field maintenance.....	93	128
Organizational.....	35	54
Postflight inspection. (See Inspection.)		
Postflight maintenance. (See Preventive maintenance.)		
Preflight inspection. (See Inspection.)		
Preflight maintenance. (See Preventive maintenance.)		
Preventive maintenance services:		
General procedure.....	44, 45	64
Schedule (table II).....	47	67
Specific procedures.....	49	65
Rate of fire, cyclic.....	3	7
Rear buffer assembly (organizational maintenance):		
Assembly and installation.....	68	98
Maintenance.....	67	96
Removal and disassembly.....	66	95
Receiver (organizational maintenance).....	81	112
Recoil mechanism:		
Function.....	83	124
Installation (field maintenance).....	116	159
Removal (field maintenance).....	114	148
Reports.....	2	6
Serial numbers of gun and tube.....	5	14
Service upon receipt of materiel:		
Cleaning.....	12	23
Disassembly prior to cleaning.....	11	22
New materiel.....	9	21
Used materiel.....	10	22
Shipment and limited storage:		
Bill of materials (table X).....	142 <i>b</i>	215
Construction of shipping container (table IX).....	142 <i>a</i>	215
Domestic shipping instructions.....	139	207
Fastening schedule (table XI).....	142 <i>c</i>	216
Loading and blocking.....	143	217
Processing, packaging, and packing.....	141	209
Spring. (See Driving spring guide group, Driving spring group, and Rear buffer springs.)		
Stoppage. (See Trouble shooting.)		
Storage, limited. (See Shipment and limited storage.)		
Table I—Special tools and equipment for organizational maintenance.....	37	54
Table II—Before firing or preflight and after firing or postflight schedule.....	47	67
Table III—Trouble shooting.....	62	93
Table IV—Special tools and equipment for field maintenance.....	95	128
Table V—Improvised tool for field maintenance.....	96	128

RESTRICTED—Security Information

	<i>Para- graphs</i>	<i>Page</i>
Table VI—Inspection guide for 20-mm automatic guns.....	98	133
Table VII—Trouble shooting.....	98	133
Table VIII—Authorized rounds for 20-mm automatic guns M24, M24E2, and M24A1.....	134	201
Table IX—Shipping box data.....	142 <i>a</i>	215
Table X—Bill of materials.....	142 <i>b</i>	215
Table XI—Fastening schedule.....	142 <i>c</i>	216
Tabulated data. (<i>See Data.</i>)		
Tools and equipment:		
Common tools and equipment:		
Field.....	94	128
Organizational.....	36	54
Improvised tool for field maintenance (table V).....	96	128
Special tools and equipment:		
Field (table IV).....	95	128
Organizational (table I).....	37	54
Trouble shooting:		
Field maintenance (table VII).....	98	133
Misfire during air firing.....	61	93
Other malfunctions (table III).....	62	93
Stoppage and misfire.....	59	91
Stoppage during ground firing.....	61	93
Tube and receiver group:		
Adjustment of lock clearance (field maintenance).....	117	161
Assembly and installation (field maintenance).....	116	159
Maintenance:		
Field.....	113, 115	148, 155
Organizational.....	79	109
Removal and disassembly (field maintenance).....	114	148
Unsatisfactory report.....	2	6
Unloading the gun.....	27	50
Unusual conditions (extreme cold, hot, etc.):		
Lubrication.....	40-43	63-64
Operation.....	28-33	50-53
Volatile corrosion inhibitor (VCI) package.....	141 <i>d</i> (2)	210

RESTRICTED—Security Information**WARNING NOTICES**

Authority for release of this document to a foreign government must be secured from the Assistant Chief of Staff, G-2, Department of the Army.

When this document is released to a foreign government, it is released subject to the following conditions: This information is furnished with the understanding that it will not be released to another nation without specific approval of the United States of America, Department of the Army; that it will not be used for other than military purposes; that individual or corporation rights originating in the information whether patented or not will be respected; and that the information will be afforded substantially the same degree of security as afforded by the United States of America, Department of the Army.

This document contains information affecting the national defense of the United States within the meaning of the Espionage Laws, Title 18 U. S. C., sections 793 and 794. The transmission or the revelation of its contents in any manner to an unauthorized person is prohibited by law.

RESTRICTED