

~~RESTRICTED~~

131 181

ALL COMMUNICATIONS SHOULD BE ACCOMPANIED BY CARBON COPY AND ADDRESSED TO

UNCLASSIFIED

TO INSURE PROMPT ATTENTION
IN REPLYING REFER TO:

WAR DEPARTMENT

OFFICE OF THE CHIEF OF ORDNANCE
WASHINGTON, D. C.

O.O. NO. 471.61 / 3128
ATTENTION OF _____

4 MAY 1945

SUBJECT: Transmittal of Technical Data

TO: The Commandant
Command and General Staff School
Fort Leavenworth, Kansas

ATTENTION: Archives

1. Transmitted herewith are copies of the technical data booklet, "Grenades." This booklet contains data and illustrations of Ordnance Department Development, Standard, Limited Standard grenades, Chemical Warfare grenades, and accessories.

2. Combat at short ranges emphasizes the use of grenades not only against personnel, tanks and armored vehicles, but also for incendiary, booby-trap, demolition, smoke and signal purposes. Special grenades are needed for the many varied conditions encountered in global warfare. These needs have resulted in the development of various grenades to meet specific field requirements.

3. Additional copies of this information may be obtained upon request.

L. H. Campbell, Jr.
L. H. CAMPBELL, Jr.
Lieutenant General, Chief of Ordnance

- 2 Incls
1. Booklet (30)
2. Receipt



UNCLASSIFIED

~~RESTRICTED~~

~~SECRET~~

A-559011

UNCLASSIFIED

RESTRICTED

Grenades

DECEMBER



1944

UNCLASSIFIED



INTRODUCTION

Combat at short ranges emphasizes the use of grenades not only against personnel, tanks and armored vehicles, but also for incendiary, booby-trap, demolition, smoke and signal purposes. Special grenades are needed for the many varied conditions encountered in global warfare. These needs have resulted in the development of various grenades to meet specific field requirements.

Progress in grenade design has resulted in grenades with increased casualty-producing effect. Penetration by fragments and the number of fragments have been increased, and such fillers as TNT, pentolite, RDX

Comp. A and RDX Comp. B., phosphorus and incendiary mixtures permit grenades to have qualities of destructiveness not possessed by earlier models.

Previously, hand grenade fuzes functioned with a certain amount of sound, smoke and sparks that permitted the enemy to determine the point from which the grenade was thrown. With the new Grenade Fuze, T2E1, standardized as M204, this hazard is eliminated, for the fuze operates noiselessly and emits neither smoke nor sparks. This feature will be incorporated in all future grenade time fuzes.

This booklet contains data and illustrations of Ordnance Department Development, Standard, Limited Standard grenades, Chemical Warfare grenades, and accessories. No attempt is made to give detailed information about grenades previously standardized. Instead, a brief statement concerning each standardized item, accompanied by a list of War Department publications in which they are fully described, suffices. On the other hand, those grenades, grenade fuzes, and accessories that have not been standardized and which, in some cases, are yet under development, are covered at considerable length.

TABLE OF CONTENTS

DEVELOPMENT ITEMS

1. Grenade, Hand, Fragmentation, Mk II (TNT), with Fuze, Grenade, Hand, T2E17
3. Grenade, Hand, Fragmentation, T13 (BEANO), with Fuze Grenade, Hand, Impact, T5E1
5. Grenade, Hand, Offensive, T15, with Fuze, Grenade, Hand, T14
7. Grenade, Hand, Illuminating, T26, with Fuze, Igniting, Hand Grenade, T18
9. Grenade, Rifle or Hand, HE, AT, T16, with Fuze, Grenade, T13
11. Grenade, Rifle or Hand, Smoke, WP, T19, with Fuze, Grenade, T1001
13. Grenade, Rifle or Hand, Smoke, HC, T17, with Fuze, Grenade, T20
 Grenade, Rifle or Hand, Smoke, Red, T20, with Fuze, Grenade, T20
 Grenade, Rifle or Hand, Smoke, Yellow, T20, with Fuze, Grenade, T20
 Grenade, Rifle or Hand, Smoke, Green, T20, with Fuze, Grenade, T20
 Grenade, Rifle or Hand, Smoke, Violet, T20, with Fuze, Grenade, T20

14. Grenade, Rifle, Smoke, Red, Streamer, T12
 Grenade, Rifle, Smoke, Yellow, Streamer, T12
 Grenade, Rifle, Smoke, Green, Streamer, T12
 Grenade, Rifle, Smoke, Violet, Streamer, T12
15. Adapter, Grenade Projection, Chemical, T2E1
16. Device, Tree Suspension, T1, for Smoke Grenade

STANDARD ARTICLES

18. Grenade, Hand, Fragmentation, Mk II (TNT), with Fuze, Detonating, Hand Grenade, M6A4C
19. Grenade, Hand, Practice, M21, with Fuze, Igniting, Hand Grenade, M10A3
20. Adapter, Grenade Projection, M1
21. Grenade, AT, M9A1
22. Grenade, Rifle, Practice, M11A3
23. Grenade, Rifle, Smoke, WP, M19 (T5E1)
24. Grenade, Rifle, Smoke, HC, M20 (T6E1)
25. Grenade, Rifle, Smoke, Red, M22 (T8E1)
 Grenade, Rifle, Smoke, Yellow, M22 (T8E1)
 Grenade, Rifle, Smoke, Green, M22 (T8E1)

Grenade, Rifle, Smoke, Violet, M22 (T8E1)

26. Grenade Cartridges
 Grenade Launchers

LIMITED STANDARD ARTICLES

28. Grenade, Hand, Fragmentation, Mk II A1, with Fuze, Igniting, Hand Grenade, M10A3
29. Grenade, Hand, Offensive, Mk III A1, with Fuze, Detonating, Hand Grenade, M6A4D.
30. Grenade, Rifle, Fragmentation, Impact, M17

CHEMICAL WARFARE ITEMS

32. Grenade, Smoke, White, (HC), AN-M8
 Grenade, Smoke, colored, M16 and M18
33. Grenade, Hand, Smoke, (WP), M15
34. Grenade, Incendiary, AN-M14
35. Grenade, Hand, Irritant, (CN-DN), M6
 Grenade, Hand, Tear, (CN), M7

1
2
3
4
5
6
7
8
9
10
11
12
13
14
15
16
17
18
19
20
21
22
23
24
25
26
27
28
29
30
31
32
33
34
35
36
37
38
39
40
41
42
43
44
45
46
47
48
49
50
51
52
53
54
55
56
57
58
59
60
61
62
63
64
65
66
67
68
69
70
71
72
73
74
75
76
77
78
79
80
81
82
83
84
85
86
87
88
89
90
91
92
93
94
95
96
97
98
99
100

~~RESTRICTED~~

DEVELOPMENT ITEMS

UNCLASSIFIED

UNCLASSIFIED

~~RESTRICTED~~

~~RESTRICTED~~

UNCLASSIFIED



GRENADE, HAND, FRAGMENTATION, MK II (TNT), WITH FUZE, GRENADE, HAND, T2E1*

This grenade which can be thrown about 35 yd. by the average soldier, is primarily designed for use against personnel, although it may occasionally be used for light demolition work. It also may be employed in booby traps by removing the fuze and replacing it with any of the standard Corps of Engineers detonating types of "booby trap" firing devices. In conjunction with the M1 Grenade Projection Adapter, the grenade can be launched from any standard rifle or carbine.

The grenade has a serrated cast-iron body, of the familiar "pineapple" design, weighing approximately

**This fuze has now been standardized as Fuze, Grenade, Hand, M204*

17 ounces. The complete round, loaded and fuzed, weighs approximately 22 ounces, including the filler of 1.90 ounces of a mixture of flake and granular TNT (75%—25%). This grenade is fitted with the new smokeless, sparkless, noiseless fuze (Fuze, Grenade, Hand, T2E1).

The safety pin is removed from the grenade before the grenade is thrown. Although the safety pin is safe against easy withdrawal, it may be removed without excessive exertion. As the grenade leaves the hand, the safety lever releases the striker, which ignites the primer. The primer immediately ignites the 4.0- to 5.0- second time fuse which in turn initiates a 13½ grain PETN detonator. This detonates the main explosive filling of TNT. The fuze for this grenade differs in appearance from previously issued

UNCLASSIFIED

~~RESTRICTED~~

hand grenade fuzes in that the safety lever has two curved projections at its upper end which fit under the ends of a T-shaped lug on the fuze body. The T2E1 fuze produces no noise other than that of the impact of the striker on the primer and emits no smoke or sparks during its burning. Since the fuze is of the detonating type it is rather powerful.

Upon detonation of the high-explosive filler, the grenade breaks up into several hundred high-velocity fragments. It is quite effective as a casualty-producing agent within a radius of 10 yards from the point of burst. Because the larger fragments may travel 100 yd. or more with considerable velocity, the thrower and any other personnel within this radius should take cover.

The grenade body is painted olive drab, and, because of its irregular surface, has no marking on it other than a narrow yellow band at the fuze end. The fuze is also olive drab, and the name and lot number of the fuze are stamped on top of the safety lever. Each grenade is packed fuze in a fiber container. Twenty-five containers are packed in a wooden box. Dimensions of the packing box are $17\frac{3}{4}$ " x $16\frac{3}{16}$ " x $7\frac{19}{32}$ "; its over-all volume is 1.26 cu. ft., and it weighs 54.7 lb. as issued.

Detailed description and information concerning the fuze can be found in War Dept. Tech. Bulletin TB ORD 119. Use of the grenade is covered by War Dept. Basic Field Manual FM 23-30.

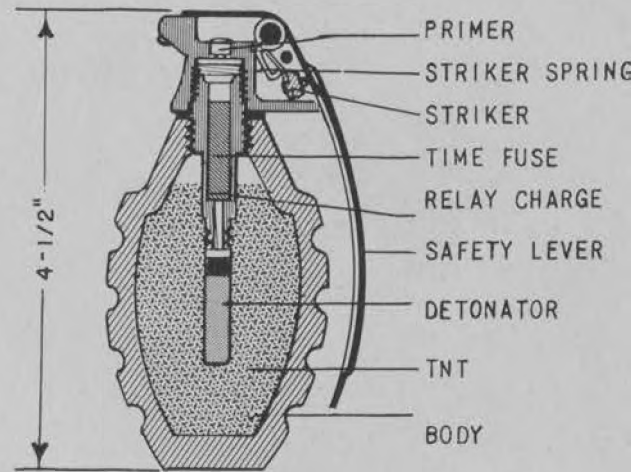



**GRENADE, HAND, FRAGMENTATION, T13,
WITH FUZE, GRENADE, HAND, T5E2**

This fragmentation grenade has a spherical steel body with .040" wall thickness and is designed primarily for use against personnel. It has an "always" fuze which functions on impact. The body is $2\frac{7}{8}$ inches in diameter and

weighs about 12 ounces when loaded with approximately 4.6 oz. of RDX Comp. A and fuzed with the T5E2 Fuze.

When throwing the grenade, the cap is held in position with the fore and middle fingers, and the safety pin is removed. In flight, the cap falls away from the body pulling out the arming pin to which it is attached by a

short string. After removal of this arming pin, the firing pin plunger and primer holder are held apart by a creep spring. On impact these parts move toward each other, the firing pin pierces and initiates the primer which in turn detonates a detonator, tetryl booster and explosive charge. Being an "always" fuze, it functions irrespective

of its position at the time of impact.

The average soldier can throw this grenade about 45 to 50 yards.

Complete information on this grenade is covered by War Department Technical Bulletin TB 9X-95.

(This grenade was developed by NDRC).

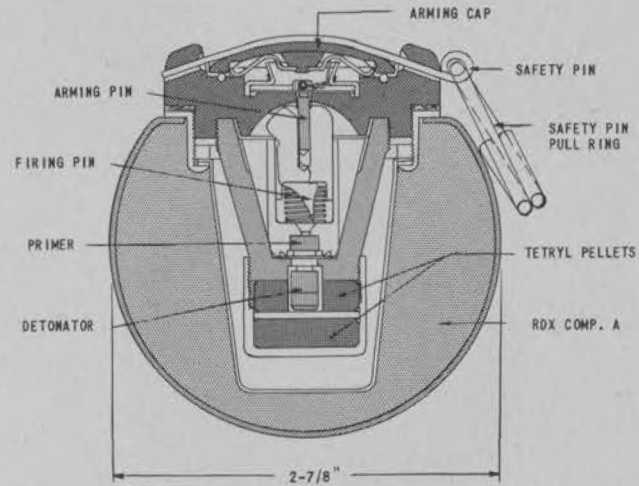



**GRENADE, HAND, OFFENSIVE, T15, WITH
FUZE, GRENADE, HAND, T14**

This grenade is designed for use as a blast or offensive grenade where adequate cover is not available to the thrower. It also has application as a light demolition charge or as an initiating charge for heavier demolition charges. The T15 grenade produces a blast greater than that of any present standard U. S. hand grenade. A spray

of small, high-velocity, magnesium fragments, effective up to about 10 ft., is produced. Almost complete safety is accorded the thrower at a distance of about 15 yd. The flame envelope is approximately 12 ft. in diameter. The average soldier can throw this grenade 45 to 50 yd.

The spherical, cast magnesium alloy body is the size of a baseball ($2\frac{7}{8}$ " in diameter) with $\frac{3}{16}$ " thick walls. The fuze is substantially all magnesium for lightness and has a 5-second delay. The fuze has a safety spring clip

which engages under the striker head. The clip is attached by a flexible wire to a magnesium cap. The cap covers the fuze and is secured to the body by means of a bayonet-type lock. A neoprene gasket under the cap seals the grenade against moisture. The fuze weighs about 0.7 ounce, and the complete grenade, loaded and fuzed, weighs about 12½ ounces. The filler consists of approximately 7 ounces of RDX Composition B.

After the cap and safety clip are removed, a sharp blow on the firing pin head by some solid object sets off a primer which ignites the powder delay train, at the end of which delay the T4 detonator, tetryl booster and the main charge

are set off. Like the T2E1 fuze, the T14 fuze functions without primer report, flash or smoke.

The grenade will be painted with a nonskid olive drab paint. The nomenclature and lot number will be stenciled in yellow on the body and in black on the firing pin head. The grenades will be packed one to a fiber container, and probably ten per wooden box.

It is proposed to inclose the grenade in a steel fragmentation case (for use as a fragmentation grenade), which can be readily removed by the thrower when the grenade is to be used offensively.

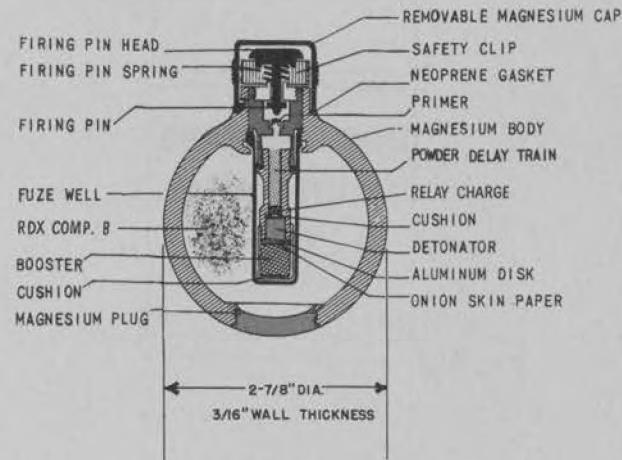

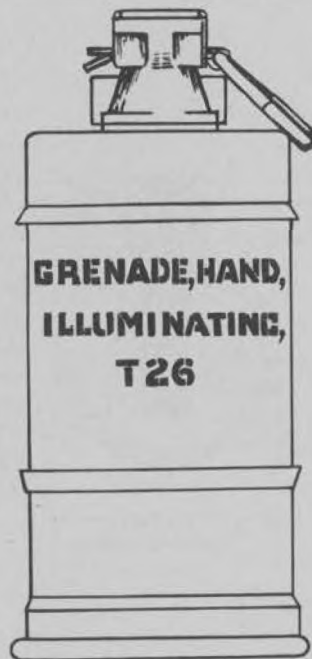

**GRENADE, HAND, ILLUMINATING, T26,
WITH FUZE, IGNITING, HAND GRENADE, T18**

The Grenade, Hand, Illuminating, T26 was designed for use in trench or fox-hole warfare to illuminate an area for investigating suspicious noises at night. It also is useful as an incendiary grenade against easily inflammable targets. The grenade can be projected from the rifle or carbine by means of the T2E1 chemical grenade projection adapter. Where used as a hand grenade this grenade can be thrown about 35 yards by the average soldier.

Some of these grenades have been shipped to theaters as Flare, Hand, Illuminating, T14 and T14E1 to fill a

special requirement. The Grenade, T26, is constructed of a cylindrical paper tube body with stamped metal base and cover. The fuze is of the noiseless, smokeless, sparkless type and is similar in construction to the T2E1 fuze but is foreshortened and contains a small amount of high-temperature flash powder as an igniter charge at the bottom instead of a detonator. The weight of the complete round, fuzed, is 21 ounces. The filler is approximately 11 ounces of pressed illuminant composition consisting chiefly of barium nitrate and aluminum powder.

Objects are most readily seen if the grenade is placed beyond them, thereby silhouetting them. For direct illumination, it is best employed if placed so that the direct light does not reach the observer—that is by firing it over some obstruction to enemy's flank so that the direct light reaches the enemy while the observer's line of sight to enemy is unobstructed. Deep grass or weeds decrease its effectiveness. If trees or high shrubbery are present, the use of Device, Tree Suspension, T1 may be desirable under some conditions. The grenade is painted olive drab with the nomenclature printed in black. It will be packed in waterproof containers.

The grenade functions in the same way as the Mk II (TNT) grenade with T2E1 fuze except that the time fuze (2 seconds) ignites a small amount of flash powder which, in turn, ignites the primed surface of the illuminant composition. After about 12 seconds of burning, the grenade reaches a maximum candle power of 45,000 (T14) or 25,000 (T14E1) or some other value to be determined later for T26. At this time the upper cover burns off and the maximum candle power is maintained almost to the end of burning. Total burning time will be determined later for the T26. (For T14 it is 55 seconds and for T14E1 90 seconds.)

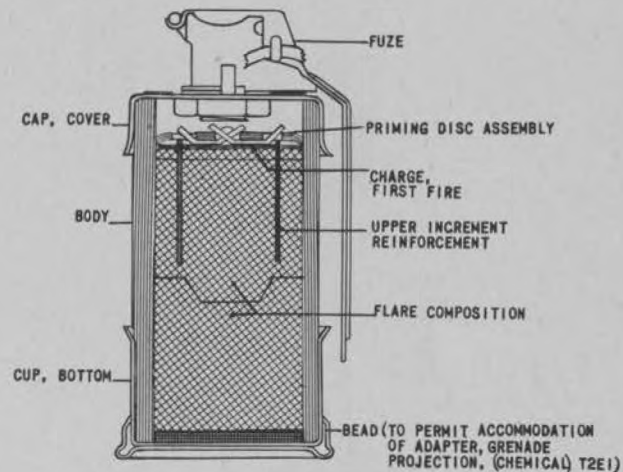



**GRENADE, RIFLE OR HAND, H.E., A.T., T16,
WITH FUZE, GRENADE, T13**

This grenade is designed to be used for the same purposes as the M9A1 Antitank Grenade and as a substitute for the Mk II Hand Grenade. In addition, it can be fired from the rifle for 5-second air burst against personnel. As a hand grenade it may be used primarily against personnel or for light demolition jobs. As a rifle grenade, its range will be approximately that of the M9A1 AT grenade. As a hand grenade, its lighter weight may result in a range somewhat greater than that of the Mk II grenade.

Inasmuch as the grenade is larger and the explosive charge is nearly 100 percent greater than that of the M9A1 AT grenade, greater armor-plate penetration should be obtained and more effective anti-personnel fragmentation should be produced by the explosive head. The increased sensitivity of the fuze when firing for impact is expected to result in improved functioning on soft ground.

This grenade combines some of the features of both

hand and rifle grenades. The head of the grenade is an enlargement of, but is similar in construction to, the M9A1 Antitank Grenade. The steel ogive, cone, and body are welded together in a smooth joint instead of a protruding crimp. The ogive has six longitudinal grooves for added strength. The stabilizer assembly consists of an extra strong aluminum tube, an improved aluminum fin, and a combination impact and time delay base-detonating fuze made of aluminum. The grenade can be fired from the rifle or carbine for impact functioning or for 5 seconds delay action, and is self-destroying after 10 seconds. It can be thrown by hand with 5 seconds delay. Two strikers are provided; one for impact, the other for the 5-second delay. An individual safety pin is fitted to each striker. The loaded head, with fuze, weighs about 17 ounces, and the complete grenade about 22 ounces. The filler consists of approximately 7.9 ounces of cast high explosive.

The grenade has an arming device for impact functioning which consists of a plug, inserted flush with and in

the side of the fuze. This plug has a stem that engages the striker pin. The plug is blown out by gases from the grenade cartridge, thus arming the grenade as it leaves the launcher. This feature allows the safe use of a more sensitive impact fuze than that in the M9A1 grenade.

The T4 detonator, the booster pellet, and the main charge may be detonated by any one of three independent means of initiation incorporated into the fuze. When the round is used as a hand grenade, the stabilizer tube and fin are detached by unscrewing (the fuze is staked to the head), the rear safety pin is removed, and the firing pin is struck sharply, setting off the primer which ignites the delay fuse. After 5 seconds the powder train flashes into the detonator, setting off the explosive filler. When the grenade is to be used as a rifle grenade, the forward safety pin is removed and the grenade is fired from a grenade launcher in the conventional manner. Upon impact, the grenade functions in the same way as the M9A1 antitank grenade. If the rear safety pin is removed, the rear firing pin is driven forward (same firing pin as for hand function-

ing) by the grenade cartridge gases setting off the primer and the explosive charge is detonated after a 5-second delay. Whenever the grenade is fired from a rifle, an independent powder delay train is ignited by the hot gases of the grenade cartridge and flashes into the detonator at the end of 10 seconds, thus providing the round with a self-destructing feature. Both the 5 and 10-second delays burn without noise, sparks, or smoke.

The grenade will be painted olive drab, and its nomenclature and lot number will be stenciled in yellow around the body. Above the forward safety pin the words "Rifle Impact" will be stenciled in yellow; below the rear safety pin will be stenciled "Hand or Rifle-Delay;" at the forward end of the stabilizer tube will be stenciled "Unscrew for hand firing" with an arrow pointing to the left. Each complete round will be packed in a fiber container, ten containers to a wooden box. The packing box will contain ten M3 cal. .30 rifle grenade cartridges, six cal. .30 M6 carbine grenade cartridges, and five M7 auxiliary grenade cartridges.

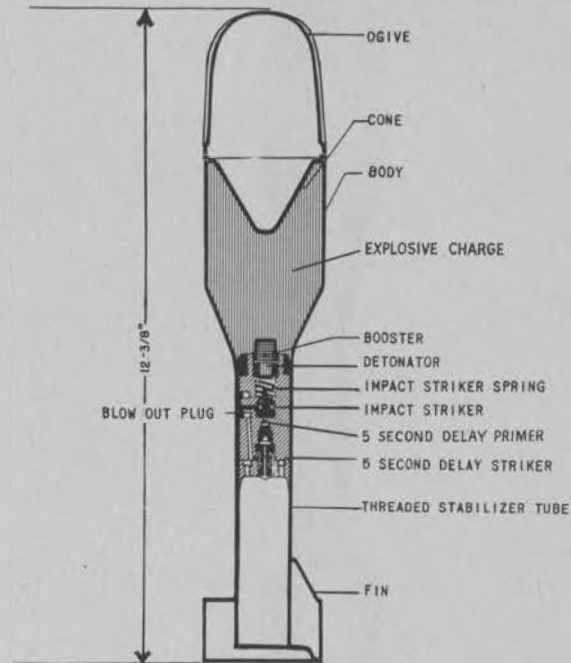



**GRENADE, RIFLE OR HAND, SMOKE, WP, T19,
WITH FUZE, GRENADE, T1001**

This grenade has the same uses as the M19 WP smoke rifle grenade and the M15 WP smoke hand grenade.

It will have approximately the same ballistics and range as the Grenade, T16. As a hand grenade it is considerably lighter than the M15 Grenade and consequently a greater range is anticipated.

The T19 is expected to be more effective than the smaller M19 WP Rifle Grenade in view of the greater amount of white phosphorus and the added possibility of obtaining air bursts. It may be somewhat less effective than the M15 WP Hand Grenade because of the smaller amount of white phosphorus, but the increased throwing radius may offer an advantage over the M15.

This grenade combines the features of hand and rifle

WP grenades. The stabilizer tube, fin, and fuze are the same as in the T16 Grenade, except that the fuse has an attached burster instead of a booster pellet. The grenade head is all aluminum with aluminum burster well. Weight of the complete round will be about 22 ounces. The filler consists of approximately 12 ounces of white phosphorus.

The grenade will function on impact, 5-second delay for

air burst, or 10-second (self-destroying) delay when fired from the rifle, and 5-second delay when thrown by hand. It is operated in the same manner as the T16 grenade.

The complete round will be painted blue-gray, and its nomenclature and lot number will be stenciled in yellow around the body. Information similar to that found on the T16 Grenade will be stenciled in yellow beside the two safety pins and on the forward end of stabilizer tube.

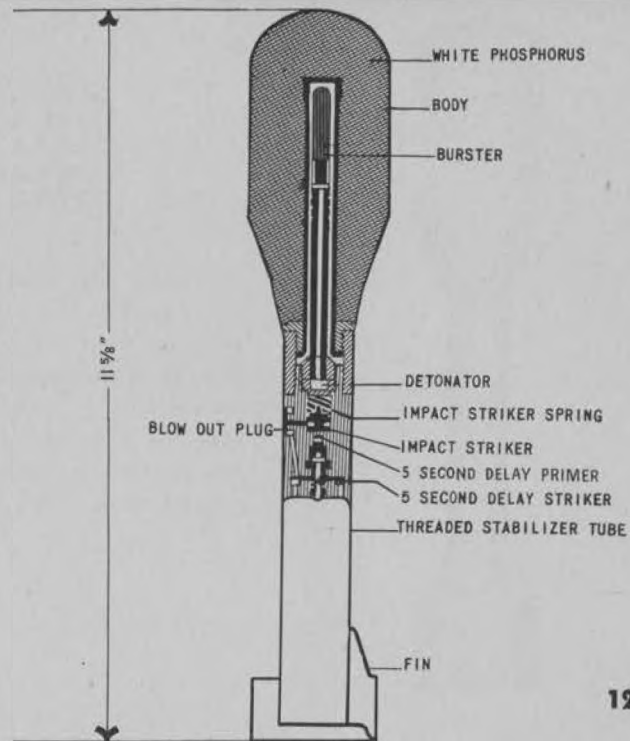



GRENADE, RIFLE OR HAND, SMOKE, HC, T17, WITH FUZE, GRENADE, T20
GRENADE, RIFLE OR HAND, SMOKE, RED, T20
GRENADE, RIFLE OR HAND, SMOKE, YELLOW, T20 } **WITH FUZE,**
GRENADE, RIFLE OR HAND, SMOKE, GREEN, T20 } **GRENADE,**
GRENADE, RIFLE OR HAND, SMOKE, VIOLET, T20 } **T20**

These combination rifle and hand grenades are being developed to complete the series begun with the T16 H.E., A.T. Rifle or Hand Grenade, and the T19 WP Smoke Rifle or Hand Grenade. They are expected to have the same range characteristics as the T16 and T19 grenades, since the weights of the complete rounds will be approximately the same. Each will be more effective than the corresponding standard M20 and M22 rifle grenades in that they will contain more smoke mixture. Like the T16 and T19 grenades, they may be employed as hand grenades. The head of the T17 will contain 13.7 ounces of HC smoke mixture, and the heads of the T20 series will contain 12.3 ounces of colored smoke mixture.





GRENADE, RIFLE, SMOKE, RED, STREAMER, T12
GRENADE, RIFLE, SMOKE, YELLOW, STREAMER, T12
GRENADE, RIFLE, SMOKE, GREEN, STREAMER, T12
GRENADE, RIFLE, SMOKE, VIOLET, STREAMER, T12

These grenades are being produced in limited quantities to fill a special requirement. The grenades, when fired from a standard rifle or carbine, give off a continuous colored smoke trail throughout full flight for ground-to-air or ground-to-ground signal purposes. Complete detailed description of these items can be found in War Department Technical Bulletin TB ORD 84.

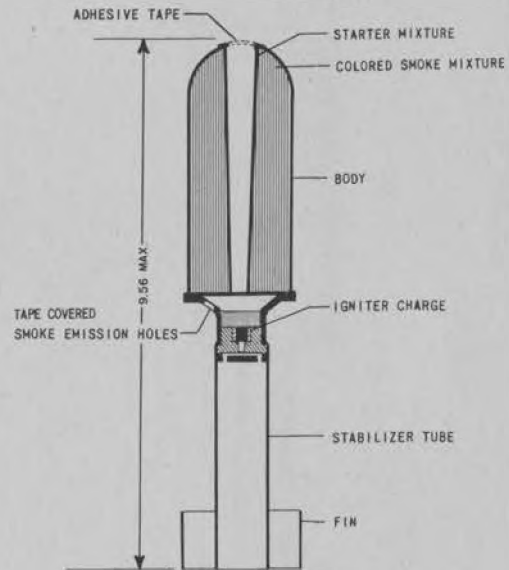



ADAPTER, GRENADE PROJECTION, CHEMICAL, T2E1

This adapter is now being procured in limited quantities to fill a special requirement and is used for launching the following grenades:

- Grenade, Hand, Irritant, CN-DM, M6
- Grenade, Hand, Gas, Irritant, CN-M7
- Grenade, Smoke, White (HC), AN-M8
- Grenade, Incendiary, AN-M14
- Grenade, Smoke, Colored, M16
- Grenade, Smoke, Colored, M18
- Grenade, Hand, Illuminating, T26

For complete detailed description and range data, see War Dept. Technical Bulletin TB ORD 114.

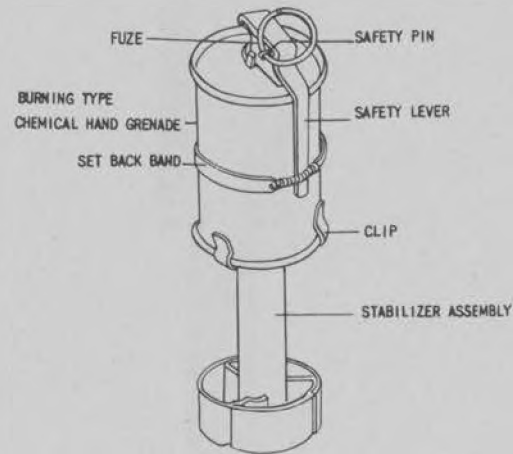

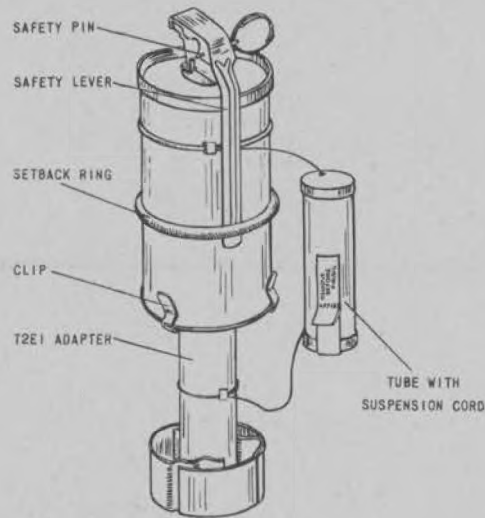

DEVICE, TREE SUSPENSION, T1, FOR SMOKE GRENADES

The smoke grenade, the adapter, and the tree suspension device are assembled prior to use, and the entire unit is fired from the launcher in the same manner as a rifle grenade. Upon firing, the assembly is projected forward and the setback ring strikes the clips of the adapter sharply, spreading them and thus separating the grenade from the adapter. In flight the grenade draws away from the adapter, pulling the cord out of the tube. The two travel together separated by the length of cord which easily becomes entangled in tree foliage, thus suspending the smoking grenade.

The device is designed to suspend colored smoke grenades in tree tops and in other foliage for more effective ground-to-air signals in heavily wooded areas.

Complete detailed description can be found in Technical Bulletin TB 9X-84.

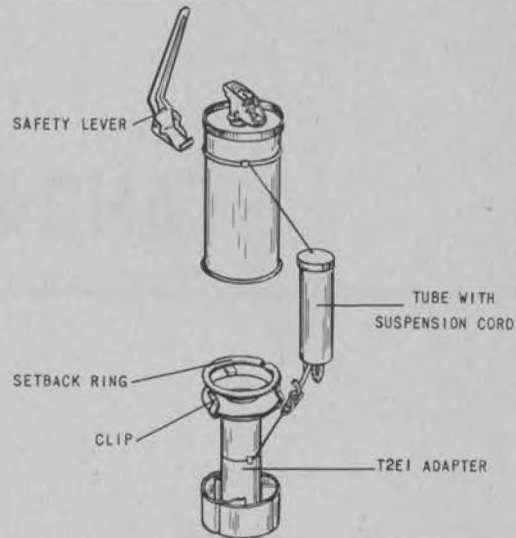

STANDARD ARTICLES



**GRENAD, HAND, FRAGMENTATION, MK II (TNT),
WITH FUZE, DETONATING, HAND GRENAD, M6A4C**

The characteristics of this grenade are the same as for the Mk II (TNT) grenade with T2E1 fuze except that, unlike the T2E1 fuze, the M6A4C fuze gives out a sharp primer report and flash on initiation, and emits smoke during burning.

The safety lever is the conventional type, having a lip that passes over the upper end of the fuze body.

For complete detailed description and information
see: War Department Technical Manual TM 9-1985
War Department Basic Field Manual FM 23-30
Army Service Forces Catalog ORD 11 SNL S-4

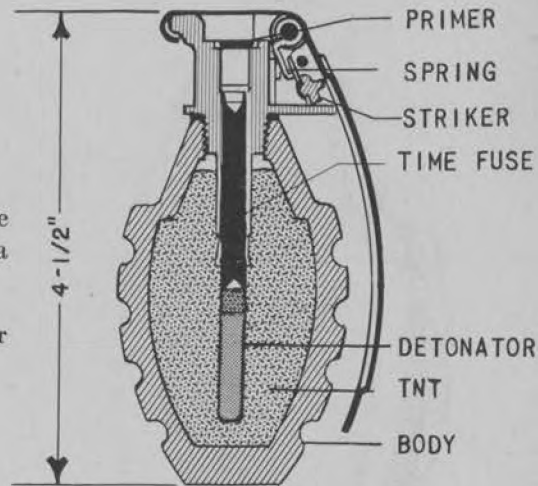



**GRENADE, HAND, PRACTICE, M21, WITH FUZE,
IGNITING, HAND, GRENADE, M10A3**

This grenade consists of a body similar to the Mk II body except for a hole in the bottom which is closed with a cork stopper. The grenade is loaded with a small black powder charge and is fuzed with a standard 4 to 5 second delay igniting fuze.

For complete detailed description and information

see: War Department Technical Manual TM 9-1985
(Grenade, Hand, Practice, Mk II)

War Department Basic Field Manual FM 23-30

Army Service Forces Catalog ORD 11 *SNL S-4*

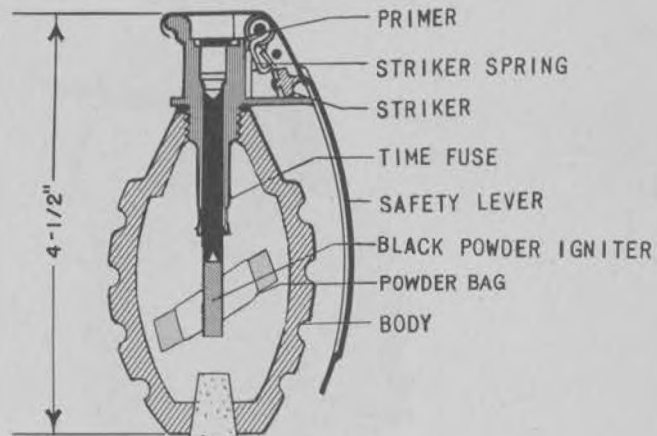



ADAPTER, GRENADE PROJECTION, M1

This item consists of a standard rifle grenade stabilizer tube and fin assembly to which is attached four spring-steel claws. One of the claws is larger than the others and is provided with an arming-clip retainer. The Mk II Hand Grenade is fitted down into the steel claws and the arming clip retainer is slipped over the fuze lever. When the safety pin is removed from the grenade, and the complete assembly is launched from the rifle, set-back causes the arming-clip to shear the arming-clip retainer, releasing the fuze safety lever and thereby arming the grenade in flight.

For complete detailed description and information

see: War Department Technical Manual TM 9-1985
War Department Basic Field Manual FM 23-30
Army Service Forces Catalog ORD 11 SNL S-4

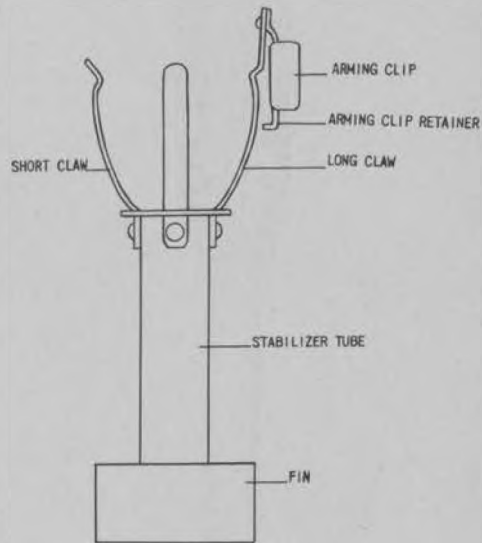



GRENADE, AT, M9A1

This rifle grenade consists of a stabilizer tube and fin assembly together with a base-detonating fuze, a body and an ogive. The body is filled with four ounces of pentolite cast into a cone shaped charge. When fired from the rifle or carbine, the firing pin initiates a detonator on impact. The detonator actuates a booster charge in the base of the main charge.

The grenade is used both as an anti-tank and anti-personnel weapon.

For complete detailed description and information

see: War Department Technical Manual TM 9-1985
War Department Basic Field Manual FM 23-30
Army Service Forces Catalog ORD 11 SNL S-4

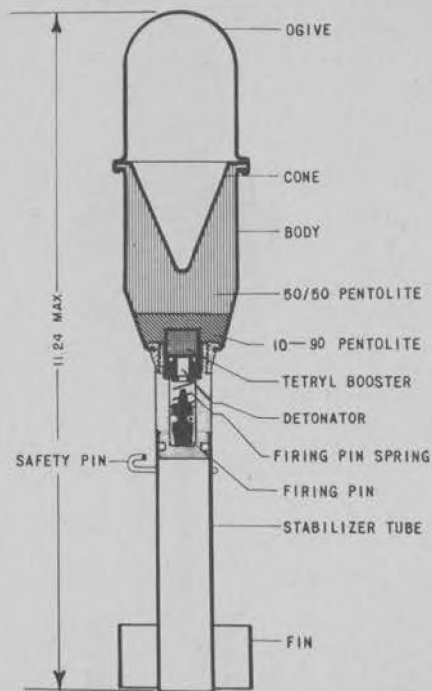



GRENADE, RIFLE, PRACTICE, M11A3

This grenade is a practice model of the M9A1 AT Grenade. Flight, weight and dimensions are the same as for the M9A1. The ogive and the fins can be replaced when damaged in use.

For complete detailed description and information

see: War Department Technical Manual 9-1985

War Department Basic Field Manual 23-30

Army Service Forces Catalog ORD 11 SNL S-4

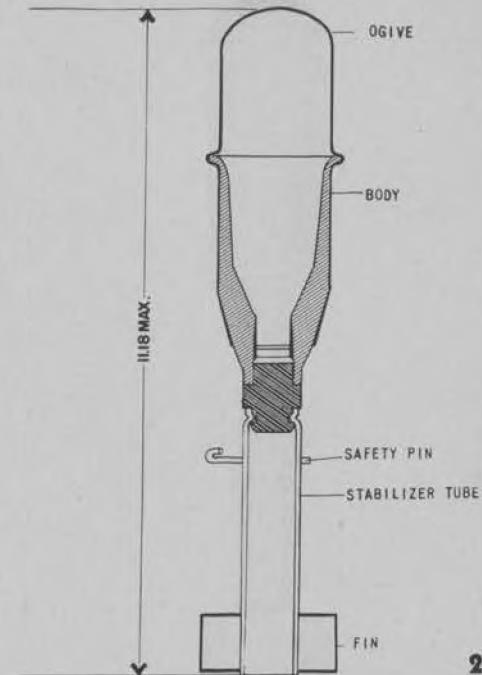



GRENADE, RIFLE, SMOKE, WP, M19 (T5E1)

This grenade is designed primarily for producing a smoke screen, but it is effective against personnel, particularly in foxholes, bunkers, and pillboxes. It is somewhat similar in appearance to the M9A1 AT Grenade and is filled with 8.5 ounces of White Phosphorus. The fuze functions instantaneously on impact. On impact the grenade bursts and disperses burning white phosphorus over an area having a radius of approximately ten yards.

For complete detailed description and information

see: War Department Technical Bulletin TB ORD 208
War Department Basic Field Manual FM 23-30
Army Service Forces Catalog ORD 11 SNL S-4

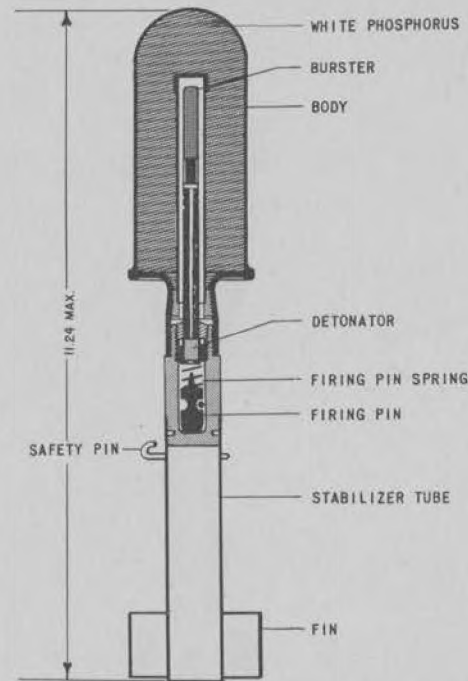



GRENADe, RIFLE, SMOKE, HC, M20 (T6E1)

This grenade is designed exclusively for screening purposes. The grenade is similar in appearance to the M19 WP rifle grenade, and is filled with 10.8 ounces of HC smoke mixture. The fuze functions on impact and ignites the smoke mixture. The smoke mixture burns for approximately one minute, giving off a dense white smoke through the emission holes in the base of the grenade body.

For complete detailed description and information

see: War Department Technical Bulletin TB ORD 208
 War Department Basic Field Manual FM 23-30
 Army Service Forces Catalog ORD 11 SNL S-4

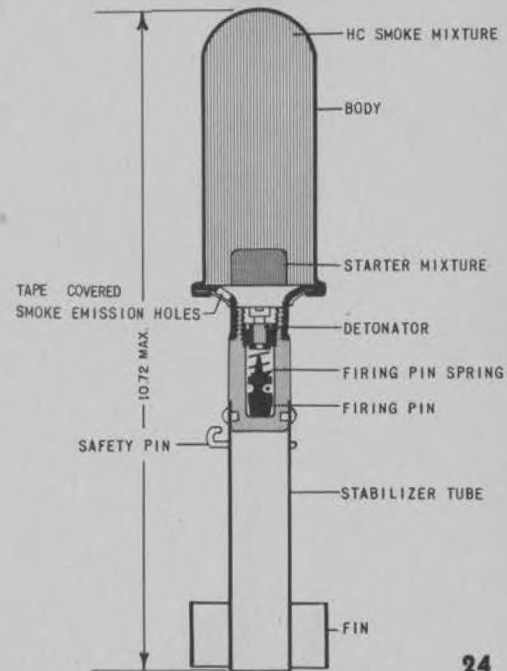



GRENAD, RIFLE, SMOKE, RED, M22 (T8E1)
GRENAD, RIFLE, SMOKE, YELLOW, M22 (T8E1)
GRENAD, RIFLE, SMOKE, GREEN, M22 (T8E1)
GRENAD, RIFLE, SMOKE, VIOLET, M22 (T8E1)

These grenades are designed exclusively for signaling. The grenade is filled with approximately 6.9 ounces of colored smoke mixture which functions on impact and burns for 45 seconds, giving off a dense colored smoke through the emission holes in the base of the grenade head.

For detailed description and information

see: War Department Technical Bulletin TB ORD 208
War Department Basic Field Manual FM 23-30
Army Service Forces Catalog ORD 11 SNL S-4

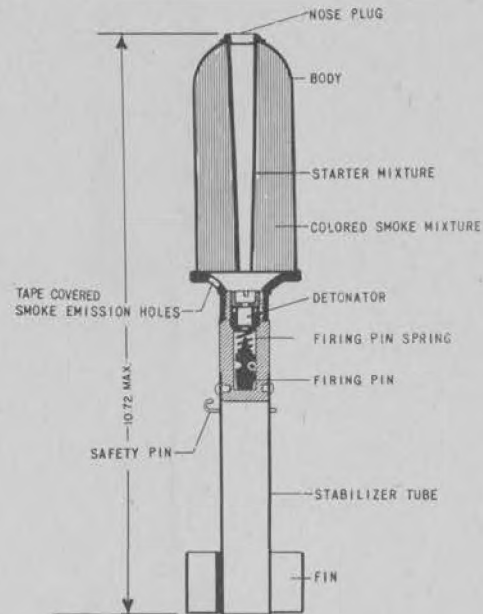



Cartridge, Rifle, Grenade, Cal. .30, M3

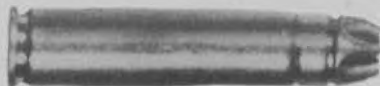

Cartridge, Grenade, Carbine, Cal. .30, M6



Cartridge, Grenade, Auxiliary, M7

GRENADE CARTRIDGES

For complete detailed description and information

see: War Department Technical Manual TM 9-1985
War Department Basic Field Manual FM 23-30
Army Service Forces Catalog ORD 11 *SNL S-4*

GRENADE LAUNCHERS

For complete detailed description and information

see: War Department Technical Manual TM 9-1985
War Department Basic Field Manual FM 23-30



Launcher, M1



Launcher, M7



Launcher, M8

LIMITED STANDARD ARTICLES



**GRENADE, HAND, FRAGMENTATION, MKIIA1, WITH
FUZE, IGNITING, HAND GRENADE, M10A3**

This fragmentation grenade consists of the standard Mk II Grenade body filled with .74 oz. of E.C. Blank Fire Powder, and the standard 4 to 5 second delay igniting fuze.

For complete detailed description and information

see: War Department Technical Manual TM 9-1985
War Department Basic Field Manual FM 23-30
Army Service Forces Catalog ORD 11 SNL S-4

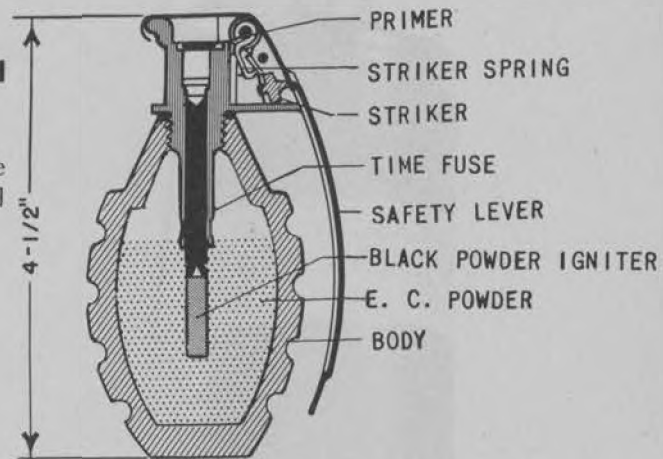



**GRENADE, HAND, OFFENSIVE, MK IIIA1, WITH FUZE,
DETONATING, HAND GRENADE, M6A4D**

This offensive grenade consists of a fiber cylinder with metal ends enclosing 6.8 oz. of pressed TNT. The grenade is actuated by a standard 4 to 5 second delay detonating fuze.

For complete detailed description and information

see: War Department Technical Manual TM 9-1985

Basic Field Manual FM 23-30

Army Service Forces Catalog ORD 11 SNL S-4

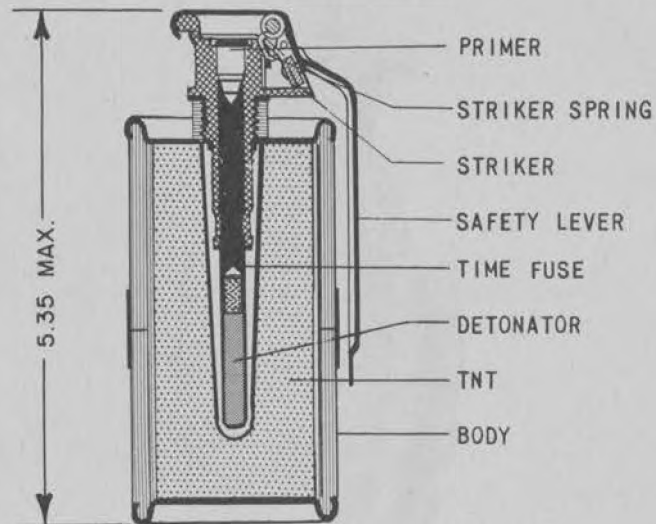



GRENADE, RIFLE, FRAGMENTATION, IMPACT, M17

This rifle grenade consists of an M9A1 grenade fuze and stabilizer assembly which is attached to a Mk II hand grenade body by a threaded coupling. The fuze is actuated on impact in the same manner as the M9A1 AT grenade.

For complete detailed description and information

see: War Department Technical Manual TM 9-1985
 War Department Basic Field Manual FM 23-30
 Army Service Forces Catalog ORD 11 SNL S-4

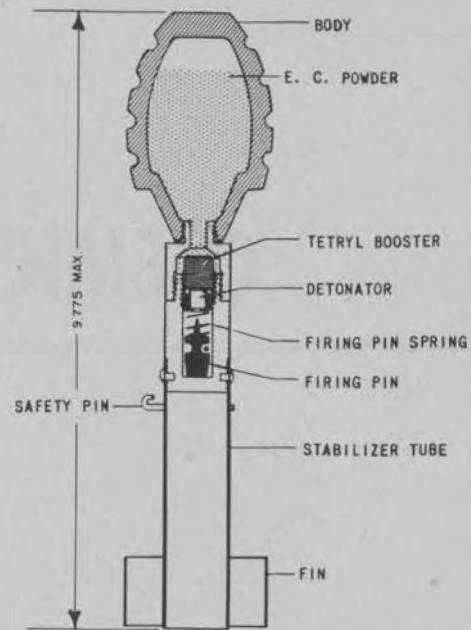

CHEMICAL WARFARE



GRENADE, SMOKE, WHITE, (HC), AN-M8, WITH FUZE, M201

War Department Technical Manual TM 9-1981
 War Department Technical Manual TM 9-1985



GRENADE, SMOKE, COLORED, M16 AND M18, WITH FUZE, M201

War Department Technical Manual TM 3-300
 War Department Basic Field Manual FM 23-30

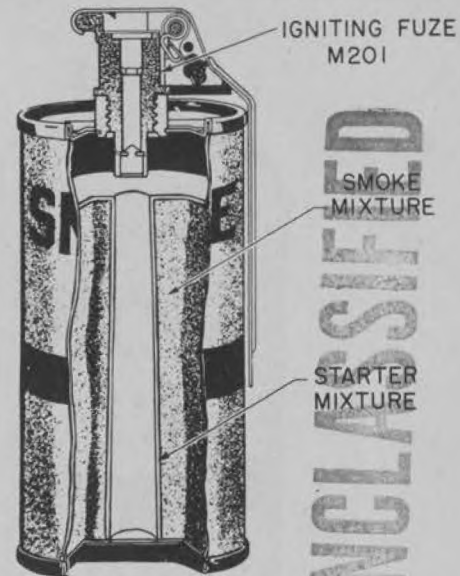

UNCLASSIFIED



**GRENADE, HAND, SMOKE, (WP), M15,
WITH FUZE—M6A3**

For complete detailed description and information

see: War Department Technical Manual TM 3-300
War Department Technical Manual TM 9-1985
War Department Basic Field Manual FM 23-30

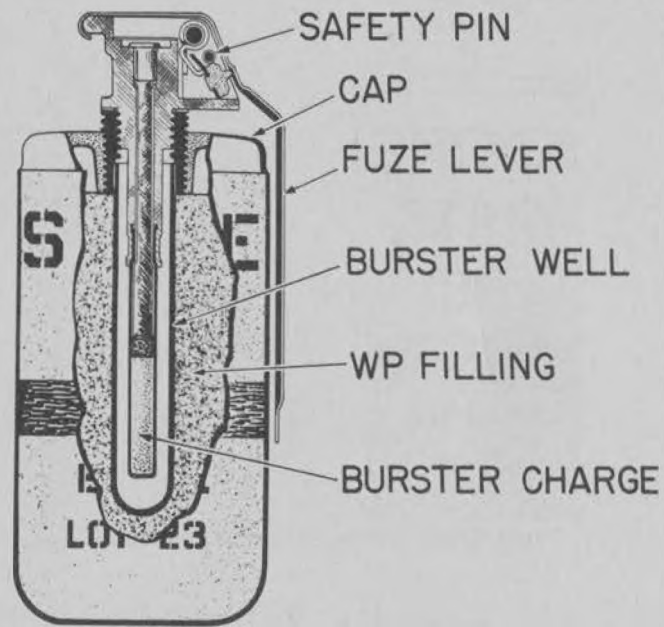

UNCLASSIFIED



GRENADE, INCENDIARY, AN-M14, WITH FUZE, M201

For detailed description and information

see: War Department Technical Manual TM 3-300
War Department Technical Manual TM 9-1985
War Department Basic Field Manual FM 23-30
War Department Technical Bulletin CW 8



UNCLASSIFIED



**GRENADE, HAND, GAS, IRRITANT, CN-DM, M6
GRENADE, HAND, TEAR, (CN), M7,
WITH FUZE, M201**

For complete detailed description and information

see: War Department Technical Manual TM 3-300
War Department Technical Manual TM 9-1985
War Department Basic Field Manual FM 23-30

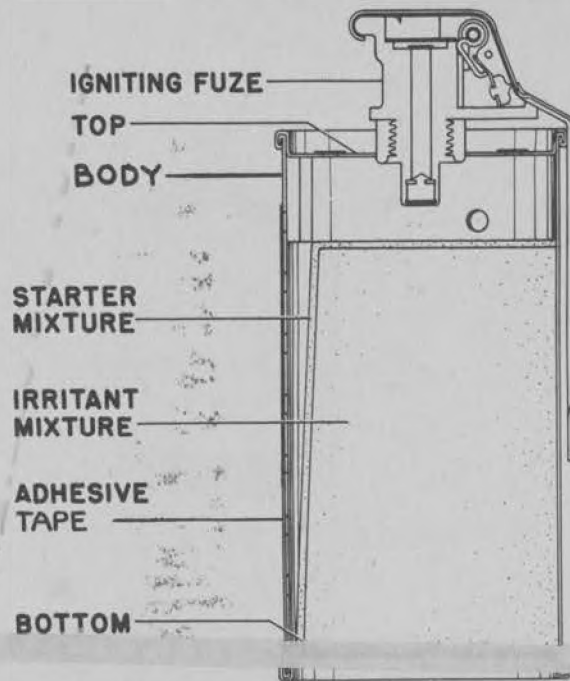

RECEIVED
MAY 10 1964
U.S. AIR FORCE
HEADQUARTERS
WASHINGTON, D.C.

RECEIVED
MAY 10 1964
U.S. AIR FORCE
HEADQUARTERS
WASHINGTON, D.C.

100-100

~~RESTRICTED~~



~~RESTRICTED~~

UNCLASSIFIED

UNCLASSIFIED

UNCLASSIFIED

GRENADERS